



BRY5266NP



BRY5269NC



BRY8266NP



BRY8269NC

Features - Specifications

- Impact/chemical-resistant toughened nylon construction
- Internal "self centering" Triple-Gripper™ cord grip with "radius teeth" design
- Double wall construction
- TPE dust seal surrounds cord to help prevent moisture and contaminants from entering wiring chamber
- Captive terminal screws are backed out and ready for wiring
- Combination Phillips/slotted terminal and assembly screws
- Wide-rib, non-slip hand grip
- Industrial black matte finish
- Transparent terminal cover features a see-thru window for proper wire terminations
- Amperage, voltage and NEMA line number imprinted on face for easy identification
- UL Listed File #E1381 – Guide #AXUT
- CSA Certified File #LR16215 – Guide #20T2
- Comply with NEMA Standards WD-1, WD-6, UL 498 and Federal Specification WC596 where applicable. See page P-1 for complete listing.
- NOM
- CE

15 AMP 125V PLUG AND CONNECTOR NEMA 5-15

CATALOG NUMBER	CORD DIA.	DESCRIPTION
BRY5266NP	.300-.655 (7.6-16.6)	Black & white nylon plug
BRY5269NC	.300-.655 (7.6-16.6)	Black & white nylon connector
BRY8266NP	.300-.655 (7.6-16.6)	White nylon plug, hospital grade
BRY8269NC	.300-.655 (7.6-16.6)	White nylon connector, hospital grade

15 AMP 250V PLUG AND CONNECTOR NEMA 6-15

BRY5666NP	.300-.655 (7.6-16.6)	Black & white nylon plug
BRY5669NC	.300-.655 (7.6-16.6)	Black & white nylon connector

20 AMP 125V PLUG AND CONNECTOR NEMA 5-20

BRY5366NP	.300-.655 (7.6-16.6)	Black & white nylon plug
BRY5369NC	.300-.655 (7.6-16.6)	Black & white nylon connector
BRY8366NP	.300-.655 (7.6-16.6)	White nylon plug, hospital grade
BRY8369NC	.300-.655 (7.6-16.6)	White nylon connector hospital grade

20 AMP 250V PLUG AND CONNECTOR NEMA 6-20

BRY5466NP	.300-.655 (7.6-16.6)	Black & white nylon plug
BRY5469NC	.300-.655 (7.6-16.6)	Black & white nylon connector
BRY8466NP	.300-.655 (7.6-16.6)	White nylon plug, hospital grade
BRY8469NC	.300-.655 (7.6-16.6)	White nylon connector, hospital grade

PRODUCT DIMENSIONS – () Indicates mm dimensions

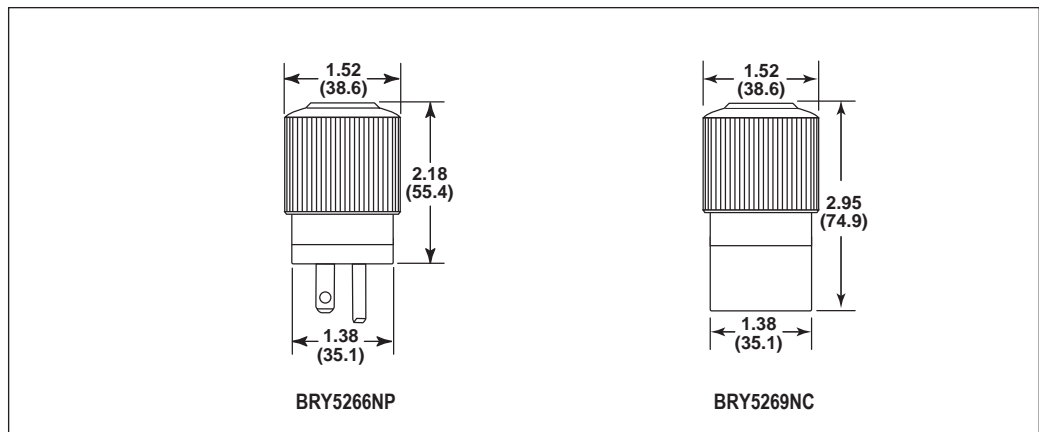

① TPE – Thermoplastic Elastomer.
See page P-3 for horsepower ratings.
Specifications are subject to change without notice.