

# PowerFlex 520-Series AC Drive Specifications

Original Instructions



Topic	Page
Product Overview	2
Catalog Number Explanation	8
Technical Specifications	9
Environmental Specifications	12
Certifications	13
Dimensions and Weights	14
Design Considerations	16
Fuses and Circuit Breaker Ratings	27
Accessories and Dimensions	36
Safe-Torque-Off Function	46
Additional Resources	51

**LISTEN.  
THINK.  
SOLVE.**

## Product Overview

The PowerFlex® 520-Series AC drive delivers an innovative design that is remarkably versatile and can accommodate systems ranging from standalone machines to simple system integration. The PowerFlex 523 drive provides general purpose control for applications ranging up to 30 HP and 22 kW. The PowerFlex 525 drive provides maximum flexibility and performance ranging up to 30 HP and 22 kW.

By combining a variety of motor control options, communications, energy savings and standard safety features in a cost-effective drive, the PowerFlex 520-Series drive is suitable for a wide array of applications.

Maximize your system performance and productivity by taking advantage of the following key features offered in a PowerFlex 520-Series drive.

## PowerFlex 520-Series AC Drives Feature

### Modular Design

- Detachable control module and power module allow **simultaneous configuration and installation**.
- Each drive has a **standard control module** used across the entire power range.
- **MainsFree™ configuration** allows you to simply connect your control module to a PC with a standard USB cable and quickly upload, download, and flash the drive with new settings.
- **Support for accessory cards** without affecting footprint.  
(PowerFlex 523 drives support one, PowerFlex 525 drives support two)

### Packaging and Mounting

- Installation can be quick and easy using the **DIN rail mounting** feature on A, B, and C frame drives. Panel mounting is also available, providing added flexibility.
- **Zero Stacking™** is allowed for ambient temperatures up to 45 °C, saving valuable panel space.
- **Integral filtering** is available on all 200V and 400V ratings, providing a cost-effective means of meeting EN61800-3 Category C2 and C3 EMC requirements. External filters provide compliance to EN61800-3 Category C1, C2, and C3 EMC requirements for all PowerFlex 520-Series ratings.
- An optional **IP 30, NEMA/UL Type 1 conduit box** is easily adapted to the standard IP 20 (NEMA Type Open) product, providing increased environmental ratings.

### Optimized Performance

- **Removable MOV** to ground provides trouble-free operation when used on ungrounded distribution systems.
- A **relay pre-charge** limits inrush current.
- **Integral brake transistor**, available on all ratings, provides dynamic braking capability with simple low cost brake resistors.
- A jumper to switch between **24V DC sink or source control** for control wiring flexibility.
- **Dual Overload Rating** available for drives above 15 HP/11 kW. Normal duty: 110% overload for 60 seconds or 150% for 3 seconds. Heavy duty: 150% overload for 60 seconds or 180% overload (200% programmable) for 3 seconds provides robust overload protection.
- **Adjustable PWM frequency up to 16 kHz** ensures quiet operation.

# PowerFlex 520-Series AC Drive Advanced Features

## Control Performance

- **Variety of motor control options, including:**
  - Volts per hertz (V/Hz)
  - Sensorless Vector Control (SVC)
  - Closed loop velocity vector control (PowerFlex 525 drives only)
- **Variety of Positioning Control, including:**
  - PointStop™ stops motor load in a consistent position without encoder feedback
  - Closed loop feedback with an optional encoder card (PowerFlex 525 drives only)
  - Point-to-point positioning mode (PowerFlex 525 drives only)
- **Integral PID** functionality enhances application flexibility (PowerFlex 523 drives have one PID loop, PowerFlex 525 drives have two PID loops)

## I/O Wiring

### PowerFlex 523

- **Two (2) Analog Inputs** (two unipolar) are independently isolated from the rest of the drive I/O.
- **Five (5) Digital Inputs** (four programmable) provide application versatility.
- **One (1) Relay Output** (form C) can be used to indicate various drive, motor or logic conditions.

### PowerFlex 525

- **Two (2) Analog Inputs** (one unipolar and one bipolar) are independently isolated from the rest of the drive I/O. These inputs can be toggled via a digital input.
- **Seven (7) Digital Inputs** (six programmable) provide application versatility.
- **One (1) Analog Output** is jumper selectable between either 0-10V or 0-20 mA. This scalable, 10-bit output is suitable for metering or as a speed reference for another drive.
- **Two (2) Opto Outputs and two (2) Relay Outputs** (one form A and one form B) can be used to indicate various drive, motor or logic conditions.

**PowerFlex 523 Control I/O Wiring Block Diagram**

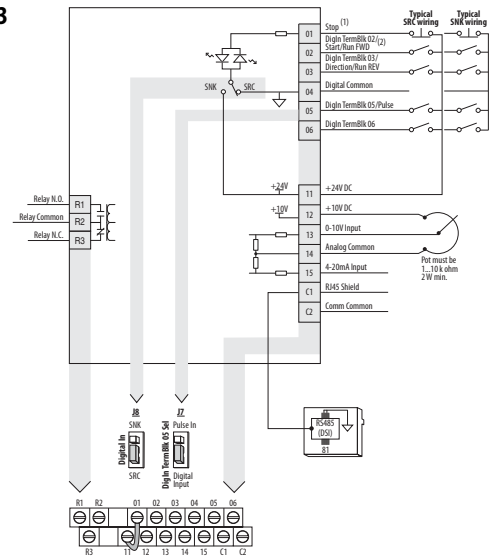

**PowerFlex 525 Control I/O Wiring Block Diagram**

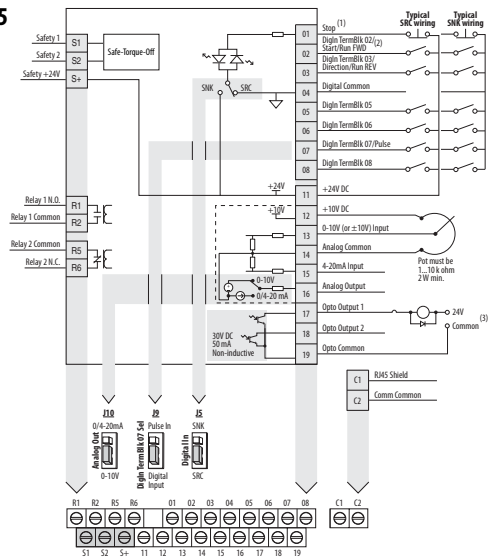

## Communications

- **Embedded EtherNet/IP™ port** allows easy configuration, control, and collection of drive data over the network. (PowerFlex 525 drives only)
- **Dual port EtherNet/IP option card** supports Device Level Ring (DLR) topologies, providing **fault-tolerant connectivity** for optimum drive availability.
- **Integral RS485/DSI communications** enable the drives to be used in a multi-drop network configuration.
- Optional communication cards such as **DeviceNet™**, and **PROFIBUS DP™** can improve machine performance.
- **Online EDS file creation** with RSNNetWorx™ providing ease of set-up on a network.

## Optimized for Common DC Bus Installations

### Enhanced Control of Internal Pre-charge

**Common DC Bus** offers additional inherent breaking capabilities by utilizing all the drives/loads on the bus for energy absorption offering higher efficiency and cost savings. The PowerFlex 520-Series drive has been optimized for use in **Common DC Bus** or **Shared DC Bus installations**.

- Configurable pre-charge control using digital inputs.
- Direct DC Bus connection to power terminal blocks.

## Improved Ride Through

### Operation Down to 1/2 Line Voltage

The PowerFlex 520-Series drive allows for the selection of **1/2 DC Bus operation**, for use in critical applications where continued drive output is desired even in the event of brown out or low voltage conditions. The PowerFlex 520-Series drive also supports **enhanced inertia ride through** for additional low voltage mitigation.

- Selectable 1/2 line voltage operation.
- Increased power loss ride through.

## Additional Features of PowerFlex 525 Drives

### Closed Loop Feedback

#### Encoder/Pulse Train Input

The PowerFlex 525 drive allows for configurable closed loop control with an optional encoder card for either speed or position feedback for improved speed regulation, basic position control, or other pulse inputs for motor control.

- Improved speed regulation
- Basic position control

### Basic Position Control

#### Local Position Control

- Position regulator with StepLogic™
  - 8 positions (local logic)

#### Outer Position Control Loop

- **Analog input bipolar mode** offers improved zero-cross performance.
- **Simple motion control** applications with more complex position profiles.
- **Speed reference** supplied to drive via Analog Input or multiple field bus network options.
- **Speed ratio** available for simple draw applications.

### Feedback Details

#### Line Driver Type Incremental Encoder Option Card

- Quadrature (dual channel) or Single Channel
- 5V/12V DC supply, 10 mA min per channel
- Single Ended or Differential (A, B Channel)
- Duty Cycle of 50%, +10%
- Input Frequency up to 250 kHz

#### Pulse Train Input

- Configurable Input Voltage 5V/12V/24V DC autodetect
- Input Frequency up to 100 kHz

#### Encoder Wiring Examples

I/O	Connection Example	I/O	Connection Example
Encoder Power – Internal Drive Power (drive) 12V DC, 250 mA		Encoder Power – External Power Source	
Encoder Signal – Single-Ended, Dual Channel		Encoder Signal – Differential, Dual Channel	

### Safety Inside using Safe-Torque-Off Function

Safe Torque-Off is a standard safety feature of the PowerFlex 525 drive to help protect personnel and equipment. Safe Torque-off allows you to restart your application faster after a safety-related situation.

- Safe Torque-Off functionality **removes rotational power without powering down the drive.**
- Embedded safety **reduces wiring and saves on installation space.**
- Meets ISO 13849-1 standards and provides safety ratings up to and including **SIL 2/PLd.**

## Communications and Software

### Versatile Programming and Network Solutions

- PowerFlex 520-Series drives are compatible with any device that acts as a **RTU Master** and supports standard 03 and 06 RTU commands.
- A network can be configured using PowerFlex 520-Series drives for **high performance and flexible configuration** capabilities.
  - Embedded port for EtherNet/IP (PowerFlex 525 drives only)
  - EtherNet/IP dual-port option card
  - DeviceNet option card
  - PROFIBUS DP option card
- A **multi-drive solution** can be reached using a single PowerFlex 520-Series drive, with the ability for up to five (5) drives to reside on one (1) node.
- **Integral RS485** communications enable the drives to be used in a multi-drop network configuration. A serial converter module (SCM) provides connectivity to any controller with a DF1 port. The SCM can be eliminated if the controller acts as a RTU Master.

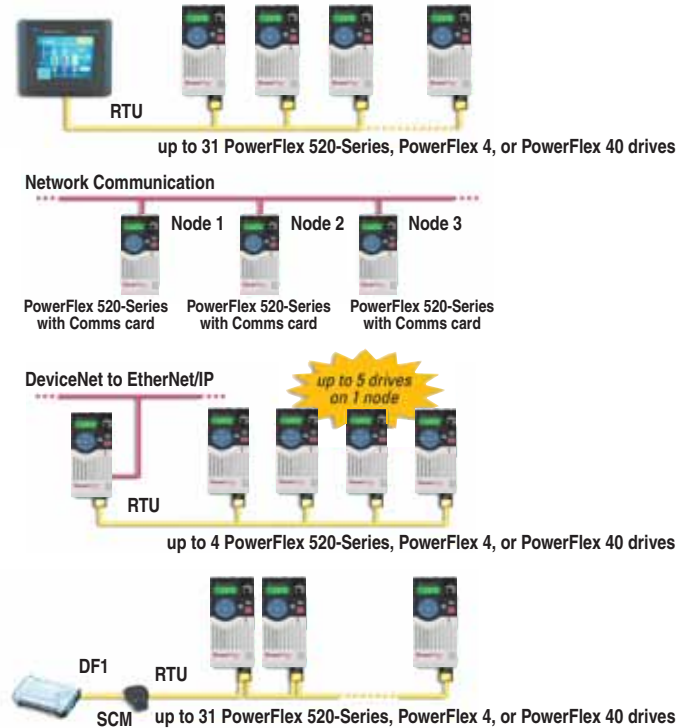

### PC Programming Software

#### Connected Components Workbench™

- Supports plug-and-play connectivity through a standard USB connection.
- AppView™ tool provides parameter groups for several of the most common applications.
- Create and save custom parameter groups using the CustomView™ tool.
- Supports PowerFlex drives, Micro800™ controllers and PanelView™ component graphic terminals.

#### Studio 5000™ Logix Designer

- Add-on profiles (AOPs) for PowerFlex 520-series AC drives provide seamless integration into the Logix environment.
- Configuration files from Studio 5000 Logix Designer<sup>(1)</sup> can be transferred directly to the PowerFlex 520-Series drive over EtherNet/IP.
- Automatic Device Configuration (ADC) uploads configuration parameters to a replaced drive, minimizing the need for a manual reconfiguration.

(1) The Logix Designer application is the rebranding of RSLogix 5000 software. You can also use RSLogix 5000 version 17 or greater.

## PowerFlex 523 Drive Family



## PowerFlex 525 Drive Family



# Catalog Number Explanation

1-3	4	5	6-8	9	10	11	12	13	14
<b>25B</b>	–	<b>B</b>	<b>2P3</b>	<b>N</b>	<b>1</b>	<b>1</b>	<b>4</b>	–	–
Drive	Dash	Voltage Rating	Rating	Enclosure	Reserved	Emission Class	Reserved	Dash	Dash

Code	Type
25A	PowerFlex 523
25B	PowerFlex 525

Code	Voltage	Phase
V	120V AC	1
A	240V AC	1
B	240V AC	3
D	480V AC	3
E	600V AC	3

Code	EMC Filter
0	No Filter
1	Filter

Code	Braking
4	Standard

Code	Interface Module
1	Standard

Code	Enclosure
N	IP20 NEMA / Open

Output Current @ 1 Phase, 100...120V Input						
Code	Amps	Frame	ND		HD	
			HP	kW	HP	kW
1P6 <sup>(1)</sup>	1.6	A	0.25	0.2	0.25	0.2
2P5	2.5	A	0.5	0.4	0.5	0.4
4P8	4.8	B	1.0	0.75	1.0	0.75
6P0	6.0	B	1.5	1.1	1.5	1.1

Output Current @ 3 Phase, 380...480V Input						
Code	Amps	Frame	ND		HD	
			HP	kW	HP	kW
1P4	1.4	A	0.5	0.4	0.5	0.4
2P3	2.3	A	1.0	0.75	1.0	0.75
4P0	4.0	A	2.0	1.5	2.0	1.5
6P0	6.0	A	3.0	2.2	3.0	2.2
010	10.5	B	5.0	4.0	5.0	4.0
013	13.0	C	7.5	5.5	7.5	5.5
017	17.0	C	10.0	7.5	10.0	7.5
024	24.0	D	15.0	11.0	15.0	11.0
030 <sup>(2)</sup>	30.0	D	20.0	15.0	15.0	11.0
037 <sup>(2)</sup>	37.0	E	25.0	18.5	20.0	15.0
043 <sup>(2)</sup>	43.0	E	30.0	22.0	25.0	18.5

Output Current @ 1 Phase, 200...240V Input						
Code	Amps	Frame	ND		HD	
			HP	kW	HP	kW
1P6 <sup>(1)</sup>	1.6	A	0.25	0.2	0.25	0.2
2P5	2.5	A	0.5	0.4	0.5	0.4
4P8	4.8	A	1.0	0.75	1.0	0.75
8P0	8.0	B	2.0	1.5	2.0	1.5
011	11.0	B	3.0	2.2	3.0	2.2

Output Current @ 3 Phase, 525...600V Input						
Code	Amps	Frame	ND		HD	
			HP	kW	HP	kW
0P9	0.9	A	0.5	0.4	0.5	0.4
1P7	1.7	A	1.0	0.75	1.0	0.75
3P0	3.0	A	2.0	1.5	2.0	1.5
4P2	4.2	A	3.0	2.2	3.0	2.2
6P6	6.6	B	5.0	4.0	5.0	4.0
9P9	9.9	C	7.5	5.5	7.5	5.5
012	12.0	C	10.0	7.5	10.0	7.5
019	19.0	D	15.0	11.0	15.0	11.0
022 <sup>(2)</sup>	22.0	D	20.0	15.0	15.0	11.0
027 <sup>(2)</sup>	27.0	E	25.0	18.5	20.0	15.0
032 <sup>(2)</sup>	32.0	E	30.0	22.0	25.0	18.5

Output Current @ 3Phase, 200...240V Input						
Code	Amps	Frame	ND		HD	
			HP	kW	HP	kW
1P6 <sup>(1)</sup>	1.6	A	0.25	0.2	0.25	0.2
2P5	2.5	A	0.5	0.4	0.5	0.4
5P0	5.0	A	1.0	0.75	1.0	0.75
8P0	8.0	A	2.0	1.5	2.0	1.5
011	11.0	A	3.0	2.2	3.0	2.2
017	17.5	B	5.0	4.0	5.0	4.0
024	24.0	C	7.5	5.5	7.5	5.5
032	32.2	D	10.0	7.5	10.0	7.5
048 <sup>(2)</sup>	48.3	E	15.0	11.0	10.0	7.5
062 <sup>(2)</sup>	62.1	E	20.0	15.0	15.0	11.0

(1) This rating is only available for PowerFlex 523 drives.  
 (2)  Normal and Heavy Duty ratings are available for this drive.



## Technical Specifications

### Protection

Specifications	PowerFlex 523	PowerFlex 525
Bus Overvoltage Trip 100...120V AC Input: 200...240V AC Input: 380...480V AC Input: 525...600V AC Input:	405V DC bus (equivalent to 150V AC incoming line) 405V DC bus (equivalent to 290V AC incoming line) 810V DC bus (equivalent to 575V AC incoming line) 1005V DC bus (equivalent to 711V AC incoming line)	
Bus Undervoltage Trip 100...120V AC Input: 200...240V AC Input: 380...480V AC Input: 525...600V AC Input P038 = 3 "600V": P038 = 2 "480V":	190V DC bus (equivalent to 75V AC incoming line) 190V DC bus (equivalent to 150V AC incoming line) 390V DC bus (equivalent to 275V AC incoming line)  487V DC bus (equivalent to 344V AC incoming line) 390V DC bus (equivalent to 275V AC incoming line)	
Power Ride-Thru:	100 ms	
Logic Control Ride-Thru:	0.5 s minimum, 2 s typical	
Electronic Motor Overload Protection:	Provides class 10 motor overload protection according to NEC article 430 and motor over-temperature protection according to NEC article 430.126 (A) (2). UL 508C File 29572.	
Overcurrent:	200% hardware limit, 300% instantaneous fault	
Ground Fault Trip:	Phase-to-ground on drive output	
Short Circuit Trip:	Phase-to-phase on drive output	

### Electrical

Specifications	PowerFlex 523	PowerFlex 525
Voltage Tolerance:	-15% / +10%	
Frequency Tolerance:	47...63 Hz	
Input Phases:	Three-phase input provides full rating. Single-phase input provides 35% rating on three-phase drives.	
Displacement Power Factor:	0.98 across entire speed range	
Maximum Short Circuit Rating:	100,000 Amps Symmetrical	
Actual Short Circuit Rating:	Determined by AIC Rating of installed fuse/circuit breaker	
Transistor Type:	Isolated Gate Bipolar Transistor (IGBT)	
Internal DC Bus Choke 200...240V AC Input: 380...480V AC Input: 525...600V AC Input:	Only for Frame E drive ratings 11 kW (15 HP) 15...18.5 kW (20...25 HP) – Heavy Duty 15...18.5 kW (20...25 HP) – Heavy Duty	

### Control

Specifications	PowerFlex 523	PowerFlex 525
Method	Sinusoidal PWM, Volts/Hertz, Sensorless Vector Control, Economizer SVC motor control, and Closed Loop Velocity Vector Control (Closed Loop Velocity Vector Control is not applicable to PowerFlex 523 drives)	
Carrier Frequency	2...16 kHz, Drive rating based on 4 kHz	
Frequency Accuracy Digital Input: Analog Input: Analog Output:	Within $\pm 0.05\%$ of set output frequency Within 0.5% of maximum output frequency, 10-Bit resolution –	$\pm 2\%$ of full scale, 10-Bit resolution

Specifications	PowerFlex 523	PowerFlex 525
Performance V/Hz (Volts per Hertz): SVC (Sensorless Vector): SVC Economizer: VVC (Velocity Vector Control):	±1% of base speed across a 60:1 speed range ±0.5% of base speed across a 100:1 speed range ±0.5% of base speed across a 100:1 speed range ±0.5% of base speed across a 60:1 speed range – Not applicable to PowerFlex 523 drives	
Performance with Encoder SVC (Sensorless Vector): SVC Economizer: VVC (Velocity Vector Control):	–	±0.1% of base speed across a 100:1 speed range ±0.1% of base speed across a 100:1 speed range ±0.1% of base speed across a 1000:1 speed range
Output Voltage Range:	0V to rated motor voltage	
Output Frequency Range:	0...500 Hz (programmable)	
Efficiency:	97.5% (typical)	
Stop Modes:	Multiple programmable stop modes including – Ramp, Coast, DC-Brake, and Ramp-to-Stop	
Accel/Decel:	Four independently programmable accel and decel times. Each time may be programmed from 0...600 s in 0.01 s increments.	
Intermittent Overload Normal Duty:	–	110% Overload capability for up to 60 s, 150% for up to 3 s Applies for power rating above 15 kW (20 HP) only. Based on 480V drive rating.
Heavy Duty:	150% Overload capability for up to 60 s, 180% for up to 3 s (200% programmable)	

### Control Inputs

Specifications	PowerFlex 523	PowerFlex 525
Digital	Bandwidth:	10 Rad/s for open and closed loop
	Quantity:	(1) Dedicated for stop (4) Programmable
	Current:	6 mA
	Type Source Mode (SRC): Sink Mode (SNK):	18...24V = ON, 0...6V = OFF 0...6V = ON, 18...24V = OFF
	Pulse Train Quantity: Input Signal: Input Frequency: Current Consumption:	(1) Shared with one of the programmable digital input terminals. Transistor contact (open collector) 0...100 kHz 7 mA @ 24V DC maximum
Analog	Quantity:	(2) Isolated, 0-10V and 4-20 mA
	Specification Resolution: 0-10V DC Analog: 4-20 mA Analog: External Pot:	(2) Isolated, -10-10V and 4-20 mA 10-bit 100k ohm input impedance 250 ohm input impedance 1...10k ohm, 2 W minimum

### Control Outputs

Specifications	PowerFlex 523	PowerFlex 525
Relay	Quantity:	(1) Programmable Form C
	Specification Resistive Rating: Inductive Rating:	(2) 1 Programmable Form A and 1 Programmable Form B 3.0 A @ 30V DC, 3.0 A @ 125V, 3.0 A @ 240V AC 0.5 A @ 30V DC, 0.5 A @ 125V, 0.5 A @ 240V AC

Specifications		PowerFlex 523	PowerFlex 525
Opto	Quantity:	–	(2) Programmable
	Specification:		30V DC, 50 mA Non-inductive
Analog	Quantity:	–	(1) Non-Isolated 0-10V or 4-20 mA
	Specification Resolution: 0-10V DC Analog: 4-20 mA Analog:		10-bit 1 k ohm minimum 525 ohm maximum







### Encoder

Specifications	PowerFlex 523	PowerFlex 525
Type:	–	Incremental, dual channel
Supply:		12V, 250 mA
Quadrature:		90°, ±27° @ 25 °C
Duty Cycle:		50%, +10%
Requirements:		Encoders must be line driver type, quadrature (dual channel) or pulse (single channel), 3.5...26V DC output, single-ended or differential and capable of supplying a minimum of 10 mA per channel. Allowable input is DC up to a maximum frequency of 250 kHz. The encoder I/O automatically scales to allow 5V, 12V and 24V DC nominal voltages.

## Environmental Specifications

Specifications	PowerFlex 523	PowerFlex 525																																		
Altitude Without derating: With derating:	See <a href="#">Current Derating Curves on page 18</a> for derating guidelines. 1000 m (3300 ft) max. Up to 4000 m (13,200 ft) max., with the exception of 600V drives at 2000 m (6600 ft) max.																																			
Surrounding Air Temperature, max. Without derating: With derating:	See <a href="#">Current Derating Curves on page 18</a> for derating guidelines. -20...50 °C (-4...122 °F) -20...60 °C (-4...140 °F) or -20...70 °C (-4...158 °F) with optional Control Module Fan kit.																																			
Storage Temperature Frame A...D: Frame E:	-40...85 °C (-40...185 °F) -40...70 °C (-40...158 °F)																																			
Atmosphere:	<p><b>IMPORTANT</b> Drive <b>must not</b> be installed in an area where the ambient atmosphere contains volatile or corrosive gas, vapors or dust. If the drive is not going to be installed for a period of time, it must be stored in an area where it will not be exposed to a corrosive atmosphere.</p>																																			
Relative Humidity:	0...95% noncondensing																																			
Shock: Vibration:	Complies with IEC 60068-2-27 Complies with IEC 60068-2-6:1995																																			
	<table border="1"> <thead> <tr> <th rowspan="2">Frame Size</th> <th colspan="2">Operating and Nonoperating</th> <th colspan="2">Nonoperating (Transportation)</th> </tr> <tr> <th>Force (Shock/Vibration)</th> <th>Mounting Type</th> <th>Force (Shock/Vibration)</th> <th>Mounting Type</th> </tr> </thead> <tbody> <tr> <td>A</td> <td>15 g / 2 g</td> <td>DIN rail or screw</td> <td>30 g/ 2.5 g</td> <td>Screw only</td> </tr> <tr> <td>B</td> <td>15 g / 2 g</td> <td>DIN rail or screw</td> <td>30 g/ 2.5 g</td> <td>Screw only</td> </tr> <tr> <td>C</td> <td>15 g / 2 g</td> <td>DIN rail or screw</td> <td>30 g/ 2.5 g</td> <td>Screw only</td> </tr> <tr> <td>D</td> <td>15 g / 2 g</td> <td>Screw only</td> <td>30 g/ 2.5 g</td> <td>Screw only</td> </tr> <tr> <td>E</td> <td>15 g / 1.5 g</td> <td>Screw only</td> <td>30 g/ 2.5 g</td> <td>Screw only</td> </tr> </tbody> </table>	Frame Size	Operating and Nonoperating		Nonoperating (Transportation)		Force (Shock/Vibration)	Mounting Type	Force (Shock/Vibration)	Mounting Type	A	15 g / 2 g	DIN rail or screw	30 g/ 2.5 g	Screw only	B	15 g / 2 g	DIN rail or screw	30 g/ 2.5 g	Screw only	C	15 g / 2 g	DIN rail or screw	30 g/ 2.5 g	Screw only	D	15 g / 2 g	Screw only	30 g/ 2.5 g	Screw only	E	15 g / 1.5 g	Screw only	30 g/ 2.5 g	Screw only	
Frame Size	Operating and Nonoperating		Nonoperating (Transportation)																																	
	Force (Shock/Vibration)	Mounting Type	Force (Shock/Vibration)	Mounting Type																																
A	15 g / 2 g	DIN rail or screw	30 g/ 2.5 g	Screw only																																
B	15 g / 2 g	DIN rail or screw	30 g/ 2.5 g	Screw only																																
C	15 g / 2 g	DIN rail or screw	30 g/ 2.5 g	Screw only																																
D	15 g / 2 g	Screw only	30 g/ 2.5 g	Screw only																																
E	15 g / 1.5 g	Screw only	30 g/ 2.5 g	Screw only																																
Conformal Coating:	Complies with: IEC 60721-3-3 to level 3C2 (chemical and gases only)																																			
Surrounding Environment Pollution Degree Pollution Degree 1 & 2:	All enclosures acceptable.																																			
Sound Pressure Level (A-weighted) Frame A & B: Frame C: Frame D: Frame E:	Measurements are taken 1 m from the drive. Maximum 53 dBA Maximum 57 dBA Maximum 64 dBA Maximum 68 dBA																																			

## Certifications

Certification	PowerFlex 523	PowerFlex 525
<b>c-UL-us</b> 	Listed to UL508C and CAN/CSA-C22.2 No. 14-05.	
<b>C-Tick</b>  <b>N223</b>	Australian Communications and Media Authority In conformity with the following: Radiocommunications Act: 1992 Radiocommunications Standard: 2008 Radiocommunications Labelling Notice: 2008 Standards applied: EN 61800-3:2004	
<b>CE</b> 	In conformity with the following European Directives: EMC Directive (2004/108/EC) Low Voltage Directive (2006/95/EC) Standards applied: EN 61800-3:2004 EN 61800-5-1:2007	
<b>TUV</b> 	Not applicable	TÜV Rheinland Standards applied: EN ISO 13849-1:2008 EN 61800-5-2:2007 EN 61508 PARTS 1-7:2010 EN 62061:2005 EN 60204-1:2009 Certified to ISO 13849-1 SIL2/PLd with embedded Safe-Torque-Off function Meets Functional Safety (FS) when used with embedded Safe-Torque-Off function
<b>ATEX</b>  <b>II (2) GD</b>	Not applicable	Certified to ATEX directive 94/9/EC Group II Category (2) GD Applications with ATEX Approved Motors
<b>KCC</b>	Korean Registration of Broadcasting and Communications Equipment Compliant with the following standards: Article 58-2 of Radio Waves Act, Clause 3	
<b>GOST-R</b>	Russian GOST-R Certificate no. POCC US.ME92.H00040	
<b>AC 156</b>	Tested by Trentec to be compliant with AC156 Acceptance Criteria for Seismic Qualification Testing of Nonstructural Components and 2003 International Building Code for worst-case seismic level for USA excluding site class F	
<b>EPRI</b> 	Electric Power Research Institute Certified compliant with the following standards: SEMI F47 IEC 61000-4-34	
<b>Lloyds Register</b>	Not applicable	Lloyd's Register Type Approval Certificate 12/10068(E1)
<b>RoHS</b>	Compliant with the European "Restriction of Hazardous Substances" Directive	

The drive is also designed to meet the appropriate portions of the following specifications:

NFPA 70 - US National Electrical Code

NEMA ICS 7.1 - Safety standards for Construction and Guide for Selection, Installation and Operation of Adjustable Speed Drive Systems.

# Dimensions and Weights

## Frame/Rating Cross-Reference

### Catalog Number Description

<b>25B</b>	-	<b>V</b>	<b>2P5</b>	<b>N</b>	<b>1</b>	<b>0</b>	<b>4</b>
Drive		Voltage Rating	Rating	Enclosure	HIM	Emission Class	Version

### PowerFlex 520-Series Drive Ratings

PowerFlex 523 Catalog No.	PowerFlex 525 Catalog No.	Output Ratings				Output Current (A)	Input Voltage Range	Total Watts Loss	Frame Size
		Normal Duty		Heavy Duty					
		HP	kW	HP	kW				
<b>100...120V AC (-15%, +10%) – 1-Phase Input, 0...230V 3-Phase Output</b>									
25A-V1P6N104	–	0.25	0.2	0.25	0.2	1.6	85...132	20.0	A
25A-V2P5N104	25B-V2P5N104	0.5	0.4	0.5	0.4	2.5	85...132	27.0	A
25A-V4P8N104	25B-V4P8N104	1.0	0.75	1.0	0.75	4.8	85...132	53.0	B
25A-V6P0N104	25B-V6P0N104	1.5	1.1	1.5	1.1	6.0	85...132	67.0	B
<b>200...240V AC (-15%, +10%) – 1-Phase Input, 0...230V 3-Phase Output</b>									
25A-A1P6N104	–	0.25	0.2	0.25	0.2	1.6	85...132	20.0	A
25A-A2P5N104	25B-A2P5N104	0.5	0.4	0.5	0.4	2.5	170...264	29.0	A
25A-A4P8N104	25B-A4P8N104	1.0	0.75	1.0	0.75	4.8	170...264	50.0	A
25A-A8P0N104	25B-A8P0N104	2.0	1.5	2.0	1.5	8.0	170...264	81.0	B
25A-A011N104	25B-A011N104	3.0	2.2	3.0	2.2	11.0	170...264	111.0	B
<b>200...240V AC (-15%, +10%) – 1-Phase Input with EMC Filter, 0...230V 3-Phase Output</b>									
25A-A1P6N114	–	0.25	0.2	0.25	0.2	1.6	85...132	20.0	A
25A-A2P5N114	25B-A2P5N114	0.5	0.4	0.5	0.4	2.5	170...264	29.0	A
25A-A4P8N114	25B-A4P8N114	1.0	0.75	1.0	0.75	4.8	170...264	53.0	A
25A-A8P0N114	25B-A8P0N114	2.0	1.5	2.0	1.5	8.0	170...264	84.0	B
25A-A011N114	25B-A011N114	3.0	2.2	3.0	2.2	11.0	170...264	116.0	B
<b>200...240V AC (-15%, +10%) – 3-Phase Input, 0...230V 3-Phase Output</b>									
25A-B1P6N104	–	0.25	0.2	0.25	0.2	1.6	85...132	20.0	A
25A-B2P5N104	25B-B2P5N104	0.5	0.4	0.5	0.4	2.5	170...264	29.0	A
25A-B5P0N104	25B-B5P0N104	1.0	0.75	1.0	0.75	5.0	170...264	50.0	A
25A-B8P0N104	25B-B8P0N104	2.0	1.5	2.0	1.5	8.0	170...264	79.0	A
25A-B011N104	25B-B011N104	3.0	2.2	3.0	2.2	11.0	170...264	107.0	A
25A-B017N104	25B-B017N104	5.0	4.0	5.0	4.0	17.5	170...264	148.0	B
25A-B024N104	25B-B024N104	7.5	5.5	7.5	5.5	24.0	170...264	259.0	C
25A-B032N104	25B-B032N104	10.0	7.5	10.0	7.5	32.2	170...264	323.0	D
25A-B048N104	25B-B048N104	15.0	11.0	10.0	7.5	48.3	170...264	584.0	E
25A-B062N104	25B-B062N104	20.0	15.0	15.0	11.0	62.1	170...264	708.0	E
<b>380...480V AC (-15%, +10%) – 3-Phase Input, 0...460V 3-Phase Output<sup>(1)</sup></b>									
25A-D1P4N104	25B-D1P4N104	0.5	0.4	0.5	0.4	1.4	323...528	27.0	A
25A-D2P3N104	25B-D2P3N104	1.0	0.75	1.0	0.75	2.3	323...528	37.0	A
25A-D4P0N104	25B-D4P0N104	2.0	1.5	2.0	1.5	4.0	323...528	80.0	A
25A-D6P0N104	25B-D6P0N104	3.0	2.2	3.0	2.2	6.0	323...528	86.0	A
25A-D010N104	25B-D010N104	5.0	4.0	5.0	4.0	10.5	323...528	129.0	B
25A-D013N104	25B-D013N104	7.5	5.5	7.5	5.5	13.0	323...528	170.0	C
25A-D017N104	25B-D017N104	10.0	7.5	10.0	7.5	17.0	323...528	221.0	C
25A-D024N104	25B-D024N104	15.0	11.0	15.0	11.0	24.0	323...528	303.0	D
25A-D030N104	25B-D030N104	20.0	15.0	15.0	11.0	30.0	323...528	387.0	D

PowerFlex 523 Catalog No.	PowerFlex 525 Catalog No.	Output Ratings				Output Current (A)	Input Voltage Range	Total Watts Loss	Frame Size
		Normal Duty		Heavy Duty					
		HP	kW	HP	kW				
<b>380...480V AC (-15%, +10%) – 3-Phase Input with EMC Filter, 0...460V 3-Phase Output</b>									
25A-D1P4N114	25B-D1P4N114	0.5	0.4	0.5	0.4	1.4	323...528	27.0	A
25A-D2P3N114	25B-D2P3N114	1.0	0.75	1.0	0.75	2.3	323...528	37.0	A
25A-D4P0N114	25B-D4P0N114	2.0	1.5	2.0	1.5	4.0	323...528	81.0	A
25A-D6P0N114	25B-D6P0N114	3.0	2.2	3.0	2.2	6.0	323...528	88.0	A
25A-D010N114	25B-D010N114	5.0	4.0	5.0	4.0	10.5	323...528	133.0	B
25A-D013N114	25B-D013N114	7.5	5.5	7.5	5.5	13.0	323...528	175.0	C
25A-D017N114	25B-D017N114	10.0	7.5	10.0	7.5	17.0	323...528	230.0	C
25A-D024N114	25B-D024N114	15.0	11.0	15.0	11.0	24.0	323...528	313.0	D
25A-D030N114	25B-D030N114	20.0	15.0	15.0	11.0	30.0	323...528	402.0	D
25A-D037N114	25B-D037N114	25.0	18.5	20.0	15.0	37.0	323...528	602.0	E
25A-D043N114	25B-D043N114	30.0	22.0	25.0	18.5	43.0	323...528	697.0	E
<b>525...600V AC (-15%, +10%) – 3-Phase Input, 0...575V 3-Phase Output</b>									
25A-E0P9N104	25B-E0P9N104	0.5	0.4	0.5	0.4	0.9	446...660	22.0	A
25A-E1P7N104	25B-E1P7N104	1.0	0.75	1.0	0.75	1.7	446...660	32.0	A
25A-E3P0N104	25B-E3P0N104	2.0	1.5	2.0	1.5	3.0	446...660	50.0	A
25A-E4P2N104	25B-E4P2N104	3.0	2.2	3.0	2.2	4.2	446...660	65.0	A
25A-E6P6N104	25B-E6P6N104	5.0	4.0	5.0	4.0	6.6	446...660	95.0	B
25A-E9P9N104	25B-E9P9N104	7.5	5.5	7.5	5.5	9.9	446...660	138.0	C
25A-E012N104	25B-E012N104	10.0	7.5	10.0	7.5	12.0	446...660	164.0	C
25A-E019N104	25B-E019N104	15.0	11.0	15.0	11.0	19.0	446...660	290.0	D
25A-E022N104	25B-E022N104	20.0	15.0	15.0	11.0	22.0	446...660	336.0	D
25A-E027N104	25B-E027N104	25.0	18.5	20.0	15.0	27.0	446...660	466.0	E
25A-E032N104	25B-E032N104	30.0	22.0	25.0	18.5	32.0	446...660	562.0	E

(1) A non-filtered drive is not available for 380...480V AC 25 HP (18.5 kW) and 30 HP (22.0 kW) ratings. Filtered drives are available, however you must verify that the application will support a filtered drive.

### Drive Dimensions and Weight

Dimensions are in mm and (in.). Weights are in kg and (lb).

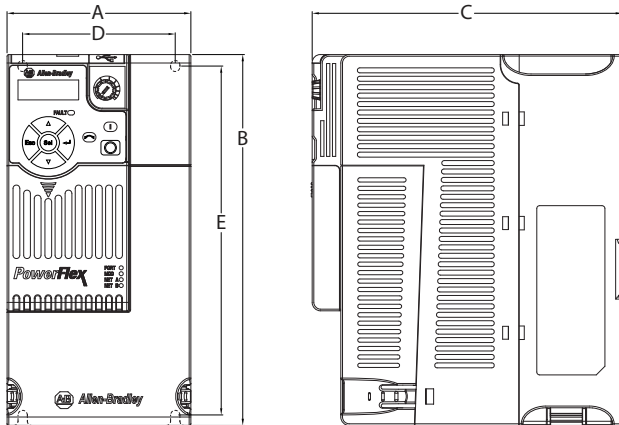

Frame Size	A	B	C	D	E	Weight
A	72.0 (2.83)	152.0 (5.98)	172.0 (6.77)	57.5 (2.26)	140.0 (5.51)	1.1 (2.4)
B	87.0 (3.43)	180.0 (7.09)	172.0 (6.77)	72.5 (2.85)	168.0 (6.61)	1.6 (3.5)
C	109.0 (4.29)	220.0 (8.66)	184.0 (7.24)	90.5 (3.56)	207.0 (8.15)	2.3 (5.0)
D	130.0 (5.12)	260.0 (10.24)	212.0 (8.35)	116.0 (4.57)	247.0 (9.72)	3.9 (8.6)
E	185.0 (7.28)	300.0 (11.81)	279.0 (10.98)	160.0 (6.30)	280.0 (11.02)	12.9 (28.4)

## Design Considerations

### Mounting Considerations

- Mount the drive upright on a flat, vertical and level surface.

Frame	Screw Size	Screw Torque
A	M5 (#10...24)	1.56...1.96 Nm (14...17 lb-in.)
B	M5 (#10...24)	1.56...1.96 Nm (14...17 lb-in.)
C	M5 (#10...24)	1.56...1.96 Nm (14...17 lb-in.)
D	M5 (#10...24)	2.45...2.94 Nm (22...26 lb-in.)
E	M8 (5/16 in.)	6.0...7.4 Nm (53...65 lb-in.)

- Protect the cooling fan by avoiding dust or metallic particles.
- Do not expose to a corrosive atmosphere.
- Protect from moisture and direct sunlight.



### Minimum Mounting Clearances

See [Dimensions and Weights on page 14](#) for mounting dimensions.

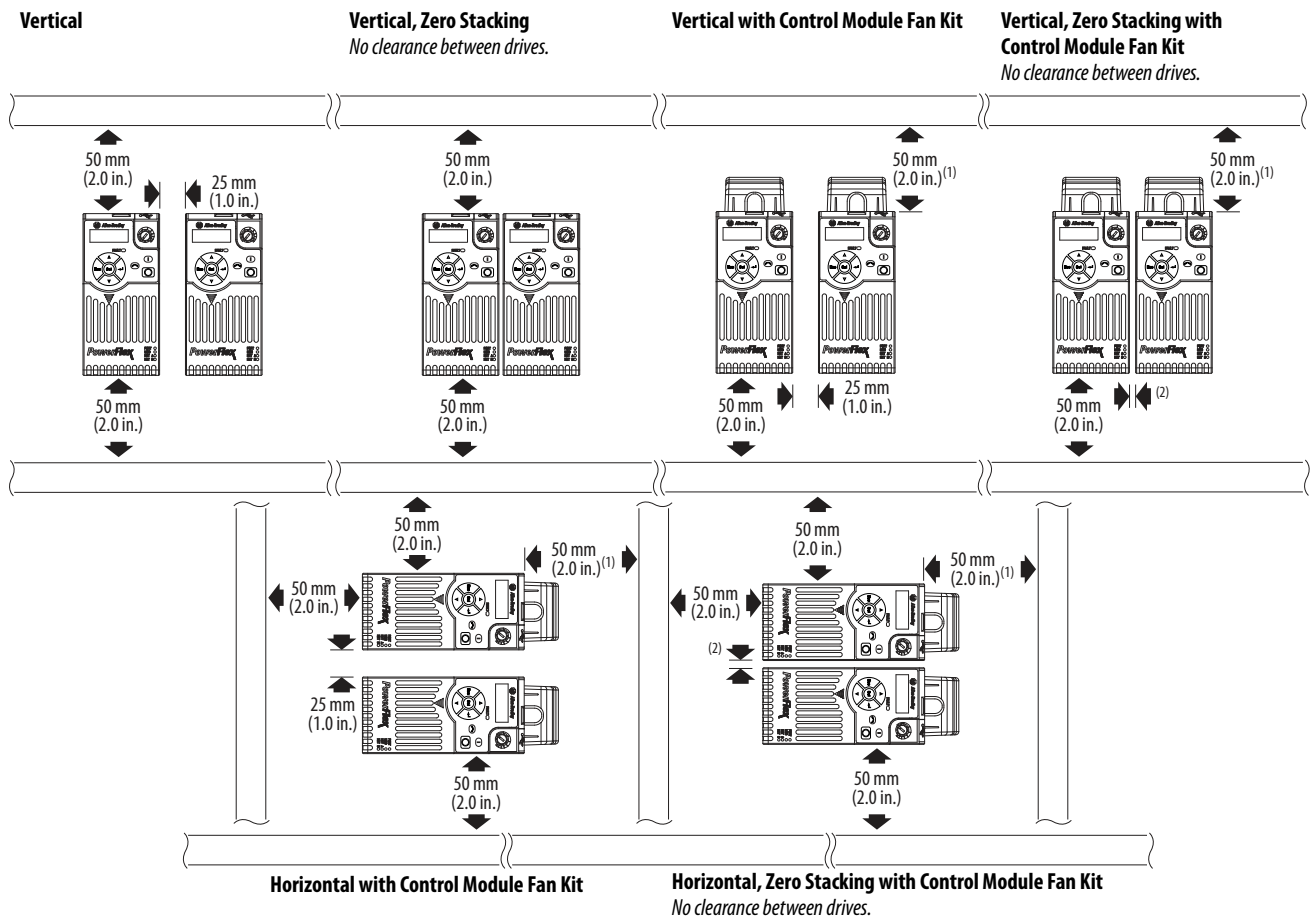

- (1) For Frame E with Control Module Fan Kit only, clearance of 95 mm (3.7 in.) is required.
- (2) For Frame E with Control Module Fan Kit only, clearance of 12 mm (0.5 in.) is required.

### Ambient Operating Temperatures

See [Accessories and Dimensions on page 36](#) for option kits.

Mounting	Enclosure Rating <sup>(1)</sup>	Ambient Temperature			
		Minimum	Maximum (No Derate)	Maximum (Derate) <sup>(2)</sup>	Maximum with Control Module Fan Kit (Derate) <sup>(3)(5)</sup>
Vertical	IP 20/Open Type	-20 °C (-4 °F)	50 °C (122 °F)	60 °C (140 °F)	70 °C (158 °F)
	IP 30/NEMA 1/UL Type 1		45 °C (113 °F)	55 °C (131 °F)	–
Vertical, Zero Stacking	IP 20/Open Type		45 °C (113 °F)	55 °C (131 °F)	65 °C (149 °F)
	IP 30/NEMA 1/UL Type 1		40 °C (104 °F)	50 °C (122 °F)	–
Horizontal with Control Module Fan Kit <sup>(4)(5)</sup>	IP 20/Open Type		50 °C (122 °F)	–	70 °C (158 °F)
Horizontal, Zero Stacking with Control Module Fan Kit <sup>(4)(5)</sup>	IP 20/Open Type		45 °C (113 °F)	–	65 °C (149 °F)

- (1) IP 30/NEMA 1/UL Type 1 rating requires installation of the PowerFlex 520-Series IP 30/NEMA 1/UL Type 1 option kit, catalog number 25-JBAX.
- (2) For catalogs 25x-D1P4N104 and 25x-E0P9N104, the temperature listed under the Max. (Derate) column is reduced by 5 °C (9 °F) for all mounting methods.
- (3) For catalogs 25x-D1P4N104 and 25x-E0P9N104, the temperature listed under the Max. with Control Module Fan Kit (Derate) column is reduced by 10 °C (18 °F) for vertical and vertical with zero stacking mounting methods only.
- (4) Catalogs 25x-D1P4N104 and 25x-E0P9N104 cannot be mounted using either of the horizontal mounting methods.
- (5) Requires installation of the PowerFlex 520-Series Control Module Fan Kit, catalog number 25-FANx-70C.

## Current Derating Curves

### Vertical Mounting

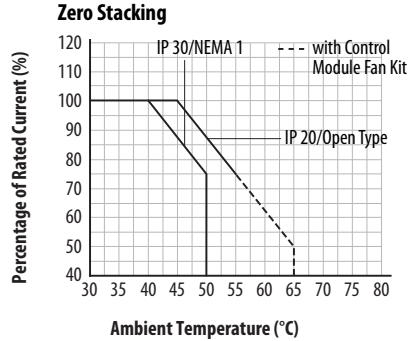
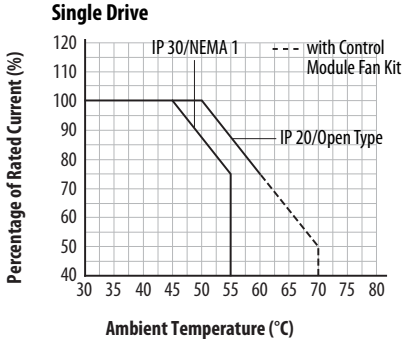

### Horizontal Mounting/Floor

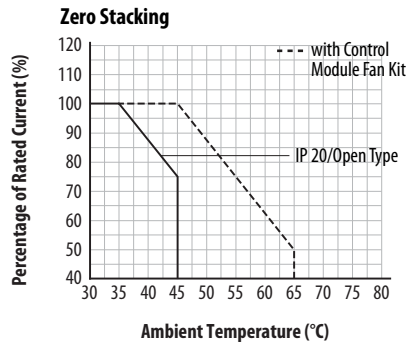
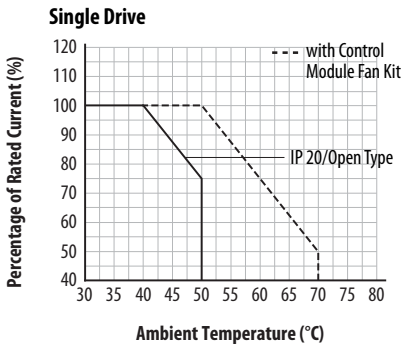

### Derating Guidelines for High Altitude

The drive can be used without derating at a maximum altitude of 1000 m (3300 ft).

If the drive is used above 1000 m (3300 ft):

- Derate the maximum ambient temperature by 5 °C (9 °F) for every additional 1000 m (3300 ft), subject to limits listed in the Altitude Limit (Based on Voltage) table below.
- Or
- Derate the output current by 10% for every additional 1000 m (3300 ft), subject to limits listed in the Altitude Limit (Based on Voltage) table below.

#### Altitude Limit (Based on Voltage)

Drive Rating	Center Ground (Wye Neutral)	Corner Ground, Impedance Ground, or Ungrounded
100...120V 1-Phase	6000 m	6000 m
200...240V 1-Phase	2000 m	2000 m
200...240V 3-Phase	6000 m	2000 m
380...480V 3-Phase	4000 m	2000 m
525...600V 3-Phase	2000 m	2000 m

## High Altitude

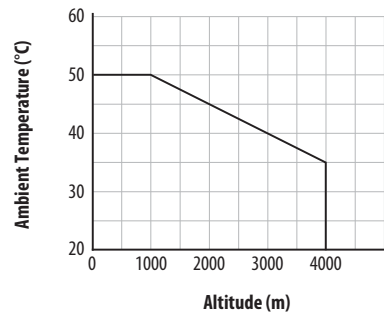
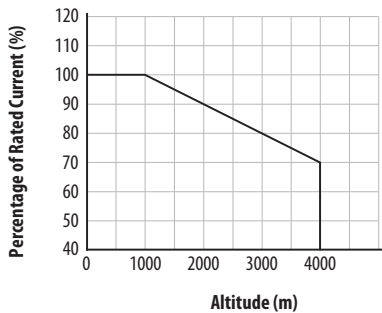

## Debris Protection

Take precautions to prevent debris from falling through the vents of the drive housing during installation.

## Storage

- Store within an ambient temperature range of -40...85 °C<sup>(1)</sup>.
- Store within a relative humidity range of 0...95%, noncondensing.
- Do not expose to a corrosive atmosphere.

(1) The maximum ambient temperature for storing a Frame E drive is 70 °C.

## AC Supply Source Considerations

### *Ungrounded Distribution Systems*



**ATTENTION:** PowerFlex 520-Series drives contain protective MOVs that are referenced to ground. These devices must be disconnected if the drive is installed on an ungrounded or resistive grounded distribution system.

**ATTENTION:** Removing MOVs in drives with an embedded filter will also disconnect the filter capacitor from earth ground.

### *Disconnecting MOVs*

To prevent drive damage, the MOVs connected to ground shall be disconnected if the drive is installed on an ungrounded distribution system (IT mains) where the line-to-ground voltages on any phase could exceed 125% of the nominal line-to-line voltage. To disconnect these devices, remove the jumper shown in the diagrams below.

1. Turn the screw counterclockwise to loosen.
2. Pull the jumper completely out of the drive chassis.
3. Tighten the screw to keep it in place.

**Jumper Location (Typical)**

**Power Module**

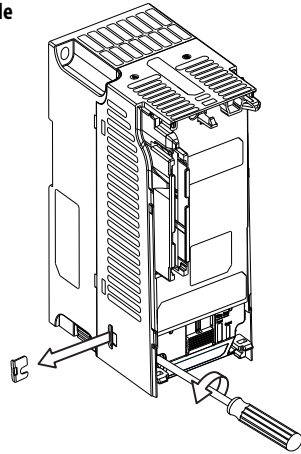

**IMPORTANT** Tighten screw after jumper removal.

**Phase to Ground MOV Removal**

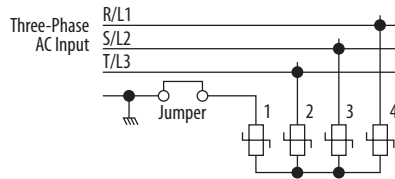

*Input Power Conditioning*

The drive is suitable for direct connection to input power within the rated voltage of the drive (see [Input Power Conditions on page 20](#)). Listed in the Input Power Conditions table below are certain input power conditions which may cause component damage or reduction in product life. If any of these conditions exist, install one of the devices listed under the heading Corrective Action on the line side of the drive.

**IMPORTANT** Only one device per branch circuit is required. It should be mounted closest to the branch and sized to handle the total current of the branch circuit.

**Input Power Conditions**

Input Power Condition	Corrective Action
Low Line Impedance (less than 1% line reactance)	<ul style="list-style-type: none"> <li>• Install Line Reactor<sup>(2)</sup></li> <li>• or Isolation Transformer</li> </ul>
Greater than 120 kVA supply transformer	
Line has power factor correction capacitors	<ul style="list-style-type: none"> <li>• Install Line Reactor<sup>(2)</sup></li> <li>• or Isolation Transformer</li> </ul>
Line has frequent power interruptions	
Line has intermittent noise spikes in excess of 6000V (lightning)	
Phase to ground voltage exceeds 125% of normal line to line voltage	<ul style="list-style-type: none"> <li>• Remove MOV jumper to ground.</li> <li>• or Install Isolation Transformer with grounded secondary if necessary.</li> </ul>
Ungrounded distribution system	
240V open delta configuration (stinger leg) <sup>(1)</sup>	<ul style="list-style-type: none"> <li>• Install Line Reactor<sup>(2)</sup></li> </ul>

(1) For drives applied on an open delta with a middle phase grounded neutral system, the phase opposite the phase that is tapped in the middle to the neutral or earth is referred to as the "stinger leg," "high leg," "red leg," etc. This leg should be identified throughout the system with red or orange tape on the wire at each connection point. The stinger leg should be connected to the center Phase B on the reactor. See [Bulletin 1321-3R Series Line Reactors on page 41](#) for specific line reactor part numbers.

(2) See [Accessories and Dimensions on page 36](#) for accessory ordering information.

## General Grounding Requirements

The drive Safety Ground - (PE) must be connected to system ground. Ground impedance must conform to the requirements of national and local industrial safety regulations and/or electrical codes. The integrity of all ground connections should be periodically checked.

### Typical Grounding

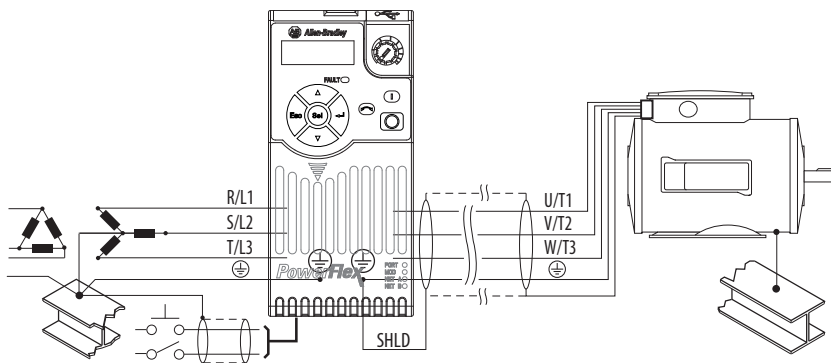

### Ground Fault Monitoring

If a system ground fault monitor (RCD) is to be used, only Type B (adjustable) devices should be used to avoid nuisance tripping.

### Safety Ground - $\ominus$ (PE)

This is the safety ground for the drive that is required by code. One of these points must be connected to adjacent building steel (girder, joist), a floor ground rod or bus bar. Grounding points must comply with national and local industrial safety regulations and/or electrical codes.

### Motor Ground

The motor ground must be connected to one of the ground terminals on the drive.

### Shield Termination - SHLD

Either of the safety ground terminals located on the power terminal block provides a grounding point for the motor cable shield. The **motor cable** shield connected to one of these terminals (drive end) should also be connected to the motor frame (motor end). Use a shield terminating or EMI clamp to connect the shield to the safety ground terminal. The earthing plate or conduit box option may be used with a cable clamp for a grounding point for the cable shield.

When shielded cable is used for **control and signal wiring**, the shield should be grounded at the source end only, not at the drive end.

## RFI Filter Grounding

Using a drive with filter may result in relatively high ground leakage currents. Therefore, the **filter must only be used in installations with grounded AC supply systems and be permanently installed and solidly grounded** (bonded) to the building power distribution ground. Ensure that the incoming supply neutral is solidly connected (bonded) to the same building power distribution ground. Grounding must not rely on flexible cables and should not include any form of plug or socket that would permit inadvertent disconnection. Some local codes may require redundant ground connections. The integrity of all connections should be periodically checked.

## Power Wiring



**ATTENTION:** National Codes and standards (NEC, VDE, BSI, etc.) and local codes outline provisions for safely installing electrical equipment. Installation must comply with specifications regarding wire types, conductor sizes, branch circuit protection and disconnect devices. Failure to do so may result in personal injury and/or equipment damage.

**ATTENTION:** To avoid a possible shock hazard caused by induced voltages, unused wires in the conduit must be grounded at both ends. For the same reason, if a drive sharing a conduit is being serviced or installed, all drives using this conduit should be disabled. This will help minimize the possible shock hazard from “cross coupled” power leads.

---

## Motor Cable Types Acceptable for 100...600 Volt Installations

A variety of cable types are acceptable for drive installations. For many installations, unshielded cable is adequate, provided it can be separated from sensitive circuits. As an approximate guide, allow a spacing of 0.3 m (1 ft) for every 10 m (32.8 ft) of length. In all cases, long parallel runs must be avoided. Do not use cable with an insulation thickness less than 15 mils (0.4 mm/0.015 in.). Do not route more than three sets of motor leads in a single conduit to minimize “cross talk”. If more than three drive/motor connections per conduit are required, shielded cable must be used.

UL installations above 50 °C ambient must use 600V, 90 °C wire.

UL installations in 50 °C ambient must use 600V, 75 °C or 90 °C wire.

UL installations in 40 °C ambient should use 600V, 75 °C or 90 °C wire.

Use copper wire only. Wire gauge requirements and recommendations are based on 75 °C. Do not reduce wire gauge when using higher temperature wire.

### Unshielded

THHN, THWN or similar wire is acceptable for drive installation in dry environments provided adequate free air space and/or conduit fill rates limits are provided. Any wire chosen must have a minimum insulation thickness of 15 mils and should not have large variations in insulation concentricity.



**ATTENTION:** Do not use THHN or similarly coated wire in wet areas.

---

## Shielded/Armored Cable

Shielded cable contains all of the general benefits of multi-conductor cable with the added benefit of a copper braided shield that can contain much of the noise generated by a typical AC Drive. Strong consideration for shielded cable should be given in installations with sensitive equipment such as weigh scales, capacitive proximity switches and other devices that may be affected by electrical noise in the distribution system. Applications with large numbers of drives in a similar location, imposed EMC regulations or a high degree of communications / networking are also good candidates for shielded cable.

Shielded cable may also help reduce shaft voltage and induced bearing currents for some applications. In addition, the increased impedance of shielded cable may help extend the distance that the motor can be located from the drive without the addition of motor protective devices such as terminator networks. Refer to Reflected Wave in “Wiring and Grounding Guide, (PWM) AC Drives,” publication [DRIVES-IN001](#).

Consideration should be given to all of the general specifications dictated by the environment of the installation, including temperature, flexibility, moisture characteristics and chemical resistance. In addition, a braided shield should be included and be specified by the cable manufacturer as having coverage of at least 75%. An additional foil shield can greatly improve noise containment.

A good example of recommended cable is Belden® 295xx (xx determines gauge). This cable has four (4) XLPE insulated conductors with a 100% coverage foil and an 85% coverage copper braided shield (with drain wire) surrounded by a PVC jacket.

Other types of shielded cable are available, but the selection of these types may limit the allowable cable length. Particularly, some of the newer cables twist 4 conductors of THHN wire and wrap them tightly with a foil shield. This construction can greatly increase the cable charging current required and reduce the overall drive performance. Unless specified in the individual distance tables as tested with the drive, these cables are not recommended and their performance against the lead length limits supplied is not known.

### Recommended Shielded Wire

Location	Rating/Type	Description
Standard (Option 1)	600V, 90 °C (194 °F) XHHW2/RHW-2 Anixter B209500-B209507, Belden 29501-29507, or equivalent	<ul style="list-style-type: none"> <li>Four tinned copper conductors with XLPE insulation.</li> <li>Copper braid/aluminum foil combination shield and tinned copper drain wire.</li> <li>PVC jacket.</li> </ul>
Standard (Option 2)	Tray rated 600V, 90 °C (194 °F) RHH/RHW-2 Anixter 0LF-7xxxxx or equivalent	<ul style="list-style-type: none"> <li>Three tinned copper conductors with XLPE insulation.</li> <li>5 mil single helical copper tape (25% overlap min.) with three bare copper grounds in contact with shield.</li> <li>PVC jacket.</li> </ul>
Class I & II; Division I & II	Tray rated 600V, 90 °C (194 °F) RHH/RHW-2 Anixter 7V-7xxxx-3G or equivalent	<ul style="list-style-type: none"> <li>Three bare copper conductors with XLPE insulation and impervious corrugated continuously welded aluminum armor.</li> <li>Black sunlight resistant PVC jacket overall.</li> <li>Three copper grounds on #10 AWG and smaller.</li> </ul>

### Reflected Wave Protection

The drive should be installed as close to the motor as possible. Installations with long motor cables may require the addition of external devices to limit voltage reflections at the motor (reflected wave phenomena). Refer to Reflected Wave in “Wiring and Grounding Guide, (PWM) AC Drives,” publication [DRIVES-IN001](#).

The reflected wave data applies to all carrier frequencies 2...16 kHz.

For 240V ratings and lower, reflected wave effects do not need to be considered.

## Output Disconnect

The drive is intended to be commanded by control input signals that will start and stop the motor. A device that routinely disconnects then reapplies output power to the motor for the purpose of starting and stopping the motor should not be used. If it is necessary to disconnect power to the motor with the drive outputting power, an auxiliary contact should be used to simultaneously disable drive (Aux Fault or Coast-to-Stop).

### Power Terminal Block Wire Specifications

Frame	Maximum Wire Size <sup>(1)</sup>	Minimum Wire Size <sup>(1)</sup>	Torque
A	5.3 mm <sup>2</sup> (10 AWG)	0.8 mm <sup>2</sup> (18 AWG)	1.76...2.16 Nm (15.6...19.1 lb-in.)
B	8.4 mm <sup>2</sup> (8 AWG)	2.1 mm <sup>2</sup> (14 AWG)	1.76...2.16 Nm (15.6...19.1 lb-in.)
C	8.4 mm <sup>2</sup> (8 AWG)	2.1 mm <sup>2</sup> (14 AWG)	1.76...2.16 Nm (15.6...19.1 lb-in.)
D	13.3 mm <sup>2</sup> (6 AWG)	5.3 mm <sup>2</sup> (10 AWG)	1.76...2.16 Nm (15.6...19.1 lb-in.)
E	26.7 mm <sup>2</sup> (3 AWG)	8.4 mm <sup>2</sup> (8 AWG)	3.09...3.77 Nm (27.3...33.4 lb-in.)

(1) Maximum/minimum sizes that the terminal block will accept – these are not recommendations.

## Common Bus/Precharge Notes

If drives are used with a disconnect switch to the common DC bus, then an auxiliary contact on the disconnect must be connected to a digital input of the drive.

## I/O Wiring

### Motor Start/Stop Precautions



**ATTENTION:** A contactor or other device that routinely disconnects and reapplies the AC line to the drive to start and stop the motor can cause drive hardware damage. The drive is designed to use control input signals that will start and stop the motor. If used, the input device must not exceed one operation per minute or drive damage can occur.

**ATTENTION:** The drive start/stop control circuitry includes solid-state components. If hazards due to accidental contact with moving machinery or unintentional flow of liquid, gas or solids exist, an additional hardwired stop circuit may be required to remove the AC line to the drive. When the AC line is removed, there will be a loss of any inherent regenerative braking effect that might be present - the motor will coast to a stop. An auxiliary braking method may be required. Alternatively, use the drive's safety input function.

Important points to remember about I/O wiring:

- Always use copper wire.
- Wire with an insulation rating of 600V or greater is recommended.
- Control and signal wires should be separated from power wires by at least 0.3 m (1 ft).

**IMPORTANT** I/O terminals labeled "Common" are not referenced to the safety ground (PE) terminal and are designed to greatly reduce common mode interference.



**ATTENTION:** Driving the 4-20 mA analog input from a voltage source could cause component damage. Verify proper configuration prior to applying input signals.



## Signal and Control Wire Types

Recommendations are for 50 °C ambient temperature.  
75 °C wire must be used for 60 °C ambient temperature.  
90 °C wire must be used for 70 °C ambient temperature.

### Recommended Signal Wire

Signal Type/Where Used	Belden Wire Type(s)(or equivalent) <sup>(1)</sup>	Description	Min. Insulation Rating
Analog I/O & PTC	8760/9460	0.750 mm <sup>2</sup> (18 AWG), twisted pair, 100% shield with drain <sup>(2)</sup>	300V, 60 °C (140 °F)
Remote Pot	8770	0.750 mm <sup>2</sup> (18 AWG), 3 conductor, shielded	
Encoder/Pulse I/O	9728/9730	0.196 mm <sup>2</sup> (24 AWG), individually shielded pairs	

(1) Stranded or solid wire.

(2) If the wires are short and contained within a cabinet which has no sensitive circuits, the use of shielded wire may not be necessary, but is always recommended.

### Recommended Control Wire for Digital I/O

Type	Wire Type(s)	Description	Min. Insulation Rating
Unshielded	Per US NEC or applicable national or local code	–	300V, 60 °C (140 °F)
Shielded	Multi-conductor shielded cable such as Belden 8770 (or equivalent)	0.750 mm <sup>2</sup> (18 AWG), 3 conductor, shielded.	

## Maximum Control Wire Recommendation

Do not exceed control wiring length of 30 m (100 ft). Control signal cable length is highly dependent on electrical environment and installation practices. To improve noise immunity, the I/O terminal block Common may be connected to ground terminal/protective earth. If using the RS485 (DSI) port, I/O Terminal C1 should also be connected to ground terminal/protective earth. Additionally, communication noise immunity can also be improved by connecting I/O Terminal C2 to ground terminal/protective earth.

### Control I/O Terminal Block Wire Specifications

Frame	Maximum Wire Size <sup>(1)</sup>	Minimum Wire Size <sup>(1)</sup>	Torque
A...E	1.3 mm <sup>2</sup> (16 AWG)	0.13 mm <sup>2</sup> (26 AWG)	0.71...0.86 Nm (6.2...7.6 lb-in.)

(1) Maximum/minimum sizes that the terminal block will accept – these are not recommendations.

## Machinery Directive (2006/42/EC)

- EN ISO 13849-1:2008 – Safety of machinery – Safety related parts of control systems -Part 1: General principles for design.
- EN 62061:2005 – Safety of machinery – Functional safety of safety-related electrical, electronic and programmable electronic control systems.
- EN 60204-1:2006 – Safety of machinery – Electrical equipment of machines - Part 1: General requirements.
- EN 61800-5-2:2007 – Adjustable speed electrical power drive systems - Part 5-2: Safety requirement – Functional.

## Connections and Grounding

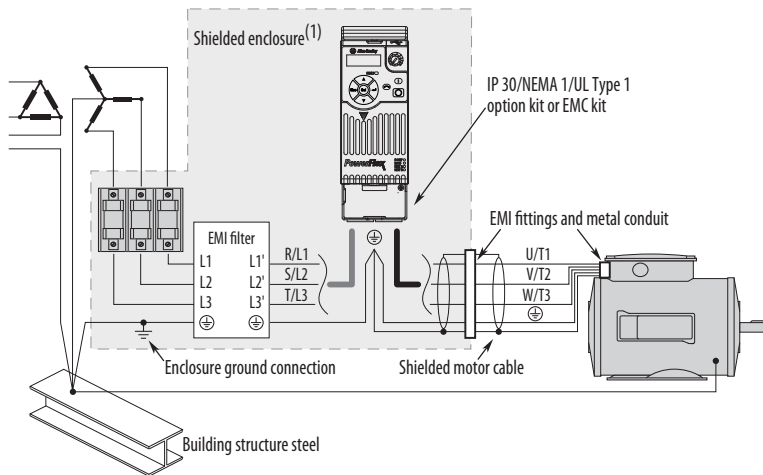

(1) Some installations require a shielded enclosure. Keep wire length as short as possible between the enclosure entry point and the EMI filter.

### PowerFlex 520-Series RF Emission Compliance and Installation Requirements

Filter Type	Standard/Limits		
	EN61800-3 Category C1 EN61000-6-3 CISPR11 Group 1 Class B	EN61800-3 Category C2 EN61000-6-4 CISPR11 Group 1 Class A (Input power ≤ 20 kVA)	EN61800-3 Category C3 (I ≤ 100 A) CISPR11 Group 1 Class A (Input power > 20 kVA)
Internal	—	10 m (33 ft)	20 m (66 ft)
External <sup>(1)</sup>	30 m (16 ft)	100 m (328 ft)	100 m (328 ft)

(1) See [Accessory Dimensions on page 43](#) for more information on optional external filters.

## Fuses and Circuit Breaker Ratings

The PowerFlex 520-Series drive does not provide branch short circuit protection. This product should be installed with either input fuses or an input circuit breaker. National and local industrial safety regulations and/or electrical codes may determine additional requirements for these installations.

The tables on pages [32...35](#) provide drive ratings and recommended AC line input fuse and circuit breaker information. Both types of short circuit protection are acceptable for UL and IEC requirements. Sizes listed are the recommended sizes based on 40 °C (104 °F) and the U.S. N.E.C. Other country, state or local codes may require different ratings.

### *Fusing*

The recommended fuse types are listed in the tables found on pages [32...35](#). If available current ratings do not match those listed in the tables provided, choose the next higher fuse rating.

- IEC – BS88 (British Standard) Parts 1 & 2<sup>(1)</sup>, EN60269-1, Parts 1 & 2, type GG or equivalent should be used.
- UL – UL Class CC, T, RK1, or J should be used.

(1) Typical designations include, but may not be limited to the following;  
Parts 1 & 2: AC, AD, BC, BD, CD, DD, ED, EFS, EF, FF, FG, GF, GG, GH.

### *Circuit Breakers*

The “non-fuse” listings in the tables found on pages [32...35](#) include inverse time circuit breakers, instantaneous trip circuit breakers (motor circuit protectors) and 140M self-protected combination motor controllers. If one of these is chosen as the desired protection method, the following requirements apply:

- IEC – Both types of circuit breakers and 140M self-protected combination motor controllers are acceptable for IEC installations.
- UL – Only inverse time circuit breakers and the specified 140M selfprotected combination motor controllers are acceptable for UL installations.

### **Bulletin 140M (Self-Protected Combination Controller)/UL489 Circuit Breakers**

When using Bulletin 140M or UL489 rated circuit breakers, the guidelines listed below must be followed in order to meet the NEC requirements for branch circuit protection.

- Bulletin 140M can be used in single motor applications.
- Bulletin 140M can be used up stream from the drive **without** the need for fuses.

## Fuses and Circuit Breakers for PowerFlex 523

### 100...120V 1-Phase Input Protection Devices – Frames A...B

Catalog No.	Output Ratings			Input Ratings		IEC (Non-UL Applications)			UL Applications			
	Heavy Duty		Max Amps <sup>(1)</sup>	kVA	Frame Size	Contactor Catalog No.	Fuses		Circuit Breakers		Circuit Breakers	
	HP	kW					Amps	Min. Rating	Max. Rating	140M		Fuses (Max. Rating) Class / Catalog No.
25A-V1P6N104	0.25	0.2	1.6	0.8	A	100-C09	10	15	140M-D6D2-B80	140M	140U-D6D2-B80	140M <sup>(2)(3)(4)</sup>
25A-V2P5N104	0.5	0.4	2.5	1.3	A	100-C12	15	20	140M-D6D2-C12	140M-C2E-C10	140U-D6D2-C12	140M-C2E-C10
25A-V4P8N104	1.0	0.75	4.8	2.5	B	100-C23	25	40	140M-D6D2-C25	140M-D8E-C20	140U-D6D2-C25	140M-D8E-C20
25A-V6P0N104	1.5	1.1	6.0	3.2	B	100-C23	30	50	140M-D6D2-C30	140M-F8E-C25	140U-D6D2-C30	140M-F8E-C25

### 200...240V 1-Phase Input Protection Devices – Frames A...B

Catalog No.	Output Ratings			Input Ratings		IEC (Non-UL Applications)			UL Applications			
	Heavy Duty		Max Amps <sup>(1)</sup>	kVA	Frame Size	Contactor Catalog No.	Fuses		Circuit Breakers		Circuit Breakers	
	HP	kW					Amps	Min. Rating	Max. Rating	140M		Fuses (Max. Rating) Class / Catalog No.
25A-A1P6N104	0.25	0.2	1.6	1.4	A	100-C07	6	10	140U-D6D2-B50	140M-C2E-B63	140U-D6D2-B50	140M <sup>(2)(3)(4)</sup>
25A-A1P6N114	0.25	0.2	1.6	1.4	A	100-C07	6	10	140U-D6D2-B50	140M-C2E-B63	140U-D6D2-B50	140M-C2E-B63
25A-A2P5N104	0.5	0.4	2.5	1.7	A	100-C09	10	15	140U-D6D2-C10	140M-C2E-C10	140U-D6D2-C10	140M-C2E-C10
25A-A2P5N114	0.5	0.4	2.5	1.7	A	100-C09	10	15	140U-D6D2-C10	140M-C2E-C10	140U-D6D2-C10	140M-C2E-C10
25A-A4P8N104	1.0	0.75	4.8	2.8	A	100-C12	15	25	140U-D6D2-C15	140M-C2E-C16	140U-D6D2-C15	140M-C2E-C16
25A-A4P8N114	1.0	0.75	4.8	2.8	A	100-C12	15	25	140U-D6D2-C15	140M-C2E-C16	140U-D6D2-C15	140M-C2E-C16
25A-A8P0N104	2.0	1.5	8.0	4.8	B	100-C23	25	40	140U-D6D2-C25	140M-F8E-C25	140U-D6D2-C25	140M-F8E-C25
25A-A8P0N114	2.0	1.5	8.0	4.8	B	100-C23	25	40	140U-D6D2-C25	140M-F8E-C25	140U-D6D2-C25	140M-F8E-C25
25A-A011N104	3.0	2.2	11.0	6.0	B	100-C37	30	50	140U-H6C2-C35	140M-F8E-C25	140U-H6C2-C35	140M-F8E-C25
25A-A011N114	3.0	2.2	11.0	6.0	B	100-C37	30	50	140U-H6C2-C35	140M-F8E-C25	140U-H6C2-C35	140M-F8E-C25

- (1) When the drive is controlling motors with lower amp ratings, refer to the drive nameplate for drive input current rating.
- (2) The AIC ratings of the Bulletin 140M Motor Protector Circuit Breakers may vary. See See [Bulletin 140M Motor Protection Circuit Breakers Application Ratings](#).
- (3) Bulletin 140M with adjustable current ranges should have the current trip set to the minimum range that the device will not trip.
- (4) Manual Self-Protected (Type E) Combination Motor Controller, UL listed for 480V/277 and 600V/347 AC input. Not UL listed for use on 480V or 600V Delta/Delta, corner ground, or high-resistance ground systems.

### Fuses and Circuit Breakers for PowerFlex 523 (continued) 200...240V 3-Phase Input Protection Devices – Frames A...E

Catalog No. <sup>(1)</sup>	Output Ratings				Input Ratings			IEC (Non-UL Applications)			UL Applications				
	Normal Duty		Heavy Duty		kVA	Max Amps <sup>(2)</sup>	Frame Size	Contactor Catalog No.	Fuses		Circuit Breakers		Fuses (Max. Rating) Class / Catalog No.	Circuit Breakers	
	HP	kW	HP	kW					Amps	Min. Rating	Max. Rating	140U		140M	140U
25A-B1P6N104	0.25	0.2	0.25	0.2	0.9	1.9	A	100-C07	3	6	140U-D6D3-B30	140M-C2E-B25	CLASS RK5, CC, J, or T / DLS-R-15	140U-D6D3-B30	140M-C2E-B25
25A-B2P5N104	0.5	0.4	0.5	0.4	1.2	2.7	A	100-C07	6	6	140U-D6D3-B40	140M-C2E-B40	CLASS RK5, CC, J, or T / DLS-R-6	140U-D6D3-B40	140M-C2E-B40
25A-B5P0N104	1.0	0.75	1.0	0.75	2.7	5.8	A	100-C09	10	15	140U-D6D3-B80	140M-C2E-B63	CLASS RK5, CC, J, or T / DLS-R-15	140U-D6D3-B80	140M-C2E-B63
25A-B8P0N104	2.0	1.5	2.0	1.5	4.3	9.5	A	100-C12	15	20	140U-D6D3-C10	140M-C2E-C10	CLASS RK5, CC, J, or T / DLS-R-20	140U-D6D3-C10	140M-C2E-C10
25A-B017N104	3.0	2.2	3.0	2.2	6.3	13.8	A	100-C23	20	30	140U-D6D3-C15	140M-C2E-C16	CLASS RK5, CC, J, or T / DLS-R-30	140U-D6D3-C15	140M-C2E-C16
25A-B017N104	5.0	4.0	5.0	4.0	9.6	21.1	B	100-C23	30	45	140U-D6D3-C25	140M-F8E-C25	CLASS CC, J, or T / 45	140U-D6D3-C25	140M-F8E-C25
25A-B024N104	7.5	5.5	7.5	5.5	12.2	26.6	C	100-C37	35	60	140U-H6C3-C35	140M-F8E-C32	CLASS CC, J, or T / 60	140U-H6C3-C35	140M-F8E-C32
25A-B032N104	10.0	7.5	10.0	7.5	15.9	34.8	D	100-C43	45	70	140U-H6C3-C60	140M-F8E-C45	CLASS RK5, CC, J, or T / DLS-R-70	—	140M-F8E-C45
25A-B048N104	15.0	11.0	10.0	7.5	20.1	44.0	E	100-C60	60	90	140U-H6C3-C70	140M-F8E-C45	CLASS CC, J, or T / 90	—	—
25S-B062N104	20.0	15.0	15.0	11.0	25.6	56.0	E	100-C72	70	125	140U-H6C3-C90	140M-H8P-C70	CLASS CC, J, or T / 125	—	—

(1) ■ Normal and Heavy Duty ratings are available for this drive.

(2) When the drive is controlling motors with lower amp ratings, refer to the drive nameplate for drive input current rating.

(3) The AIC ratings of the Bulletin 140M Motor Protector Circuit Breakers may vary. See See [Bulletin 140M Motor Protection Circuit Breakers Application Ratings](#).

(4) Bulletin 140M with adjustable current range should have the current trip set to the minimum range that the device will not trip.

(5) Manual Self-Protected (Type-E) Combination Motor Controller, UL listed for 480V/277 and 600V/347 AC input. Not UL listed for use on 480V or 600V Delta/Delta, corner ground, or high-resistance ground systems.

### Fuses and Circuit Breakers for PowerFlex 523 (continued) 380...480V 3-Phase Input Protection Devices – Frames A...E

Catalog No. (1)	Output Ratings					Input Ratings			IEC (Non-UL Applications)			UL Applications					
	Normal Duty HP	Normal Duty kW	Heavy Duty HP	Heavy Duty kW	Amps	Max kVA	Max Amps (2)	Frame Size	Contactor Catalog No.	Fuses		Circuit Breakers		Fuses (Max. Rating)		Circuit Breakers	
										Min. Rating	Max. Rating	140U	140M	Class / Catalog No.	140U	140M	Class / Catalog No.
25A-D1P4N104	0.5	0.4	0.5	0.4	1.4	1.7	1.9	A	100-C07	3	6	140U-D6D3-B30	140M-C2E-B25	CLASS RK5, CC, J, or T / DLS-R-6	140U	140M	140M-C2E-B25
25A-D1P4N114	0.5	0.4	0.5	0.4	1.4	1.7	1.9	A	100-C07	3	6	140U-D6D3-B30	140M-C2E-B25	CLASS RK5, CC, J, or T / DLS-R-6	–	–	140M-C2E-B25
25A-D2P3N104	1.0	0.75	1.0	0.75	2.3	2.9	3.2	A	100-C07	6	10	140U-D6D3-B60	140M-C2E-B40	CLASS RK5, CC, J, or T / DLS-R-10	–	–	140M-C2E-B40
25A-D2P3N114	1.0	0.75	1.0	0.75	2.3	2.9	3.2	A	100-C07	6	10	140U-D6D3-B60	140M-C2E-B40	CLASS RK5, CC, J, or T / DLS-R-10	–	–	140M-C2E-B40
25A-D4P0N104	2.0	1.5	2.0	1.5	4.0	5.2	5.7	A	100-C09	10	15	140U-D6D3-B60	140M-C2E-B63	CLASS RK5, CC, J, or T / DLS-R-15	–	–	140M-C2E-B63
25A-D4P0N114	2.0	1.5	2.0	1.5	4.0	5.2	5.7	A	100-C09	10	15	140U-D6D3-B60	140M-C2E-B63	CLASS RK5, CC, J, or T / DLS-R-15	–	–	140M-C2E-B63
25A-D6P0N104	3.0	2.2	3.0	2.2	6.0	6.9	7.5	A	100-C09	10	15	140U-D6D3-C10	140M-C2E-C10	CLASS RK5, CC, J, or T / DLS-R-15	–	–	140M-C2E-C10
25A-D6P0N114	3.0	2.2	3.0	2.2	6.0	6.9	7.5	A	100-C09	10	15	140U-D6D3-C10	140M-C2E-C10	CLASS RK5, CC, J, or T / DLS-R-15	–	–	140M-C2E-C10
25A-D010N104	5.0	4.0	5.0	4.0	10.5	12.6	13.8	B	100-C23	20	30	140U-D6D3-C15	140M-C2E-C16	CLASS RK5, CC, J, or T / DLS-R-30	–	–	140M-C2E-C16
25A-D010N114	5.0	4.0	5.0	4.0	10.5	12.6	13.8	B	100-C23	20	30	140U-D6D3-C15	140M-C2E-C16	CLASS RK5, CC, J, or T / DLS-R-30	–	–	140M-C2E-C16
25A-D013N104	7.5	5.5	7.5	5.5	13.0	14.1	15.4	C	100-C23	20	35	140U-D6D3-C25	140M-D8E-C20	CLASS CC, J, or T / 35	–	–	140M-D8E-C20
25A-D013N114	7.5	5.5	7.5	5.5	13.0	14.1	15.4	C	100-C23	20	35	140U-D6D3-C25	140M-D8E-C20	CLASS CC, J, or T / 35	–	–	140M-D8E-C20
25A-D017N104	10.0	7.5	10.0	7.5	17.0	16.8	18.4	C	100-C23	25	40	140U-D6D3-C25	140M-D8E-C20	CLASS CC, J, or T / 40	–	–	140M-D8E-C20
25A-D017N114	10.0	7.5	10.0	7.5	17.0	16.8	18.4	C	100-C23	25	40	140U-D6D3-C25	140M-D8E-C20	CLASS CC, J, or T / 40	–	–	140M-D8E-C20
25A-D024N104	15.0	11.0	15.0	11.0	24.0	24.1	26.4	D	100-C37	35	60	140U-H6C3-C40	140M-F8E-C32	CLASS CC, J, or T / 60	–	–	–
25A-D024N114	15.0	11.0	15.0	11.0	24.0	24.1	26.4	D	100-C37	35	60	140U-H6C3-C40	140M-F8E-C32	CLASS CC, J, or T / 60	–	–	–
25A-D030N104	20.0	15.0	15.0	11.0	30.0	30.2	33.0	D	100-C43	45	70	140U-H6C3-C50	140M-F8E-C45	CLASS CC, J, or T / 70	–	–	–
25A-D030N114	20.0	15.0	15.0	11.0	30.0	30.2	33.0	D	100-C43	45	70	140U-H6C3-C50	140M-F8E-C45	CLASS CC, J, or T / 70	–	–	–
25A-D037N114	25.0	18.5	20.0	15.0	37.0	30.8	33.7	E	100-C43	45	70	140U-H6C3-C50	140M-F8E-C45	CLASS CC, J, or T / 70	–	–	140M-F8E-C45
25A-D043N114	30.0	22.0	25.0	18.5	43.0	35.6	38.9	E	100-C60	50	80	140U-H6C3-C60	140M-F8E-C45	CLASS CC, J, or T / 80	–	–	140M-F8E-C45

- (1) Normal and Heavy Duty ratings are available for this drive
- (2) When the drive is controlling motors with lower amp ratings, refer to the drive nameplate for drive input current rating.
- (3) The AIC ratings of the Bulletin 140M Motor Protector Circuit Breakers may vary. See See [Bulletin 140M Motor Protection Circuit Breakers Application Ratings](#).
- (4) Bulletin 140M with adjustable current range should have the current trip set to the minimum range that the device will not trip.
- (5) Manual Self-Protected (Type E) Combination Motor Controller, UL listed for 480V/277 and 600V/347 AC input. Not UL listed for use on 480V or 600V Delta/Delta, corner ground, or high-resistance ground systems.

## Fuses and Circuit Breakers for PowerFlex 523 (continued)

### 525...600V 3-Phase Input Protection Devices – Frames A...E

Catalog No. <sup>(1)</sup>	Output Ratings				Input Ratings			IEC (Non-UL Applications)			UL Applications				
	Normal Duty		Heavy Duty		Max Amps <sup>(2)</sup>	Frame Size	Contactor Catalog No.	Fuses		Circuit Breakers		Fuses (Max. Rating)		Circuit Breakers	
	HP	kW	HP	kW				Amps	kVA	Min. Rating	Max. Rating	140U	140M	Class / Catalog No.	140U
25A-E0P9N104	0.5	0.4	0.5	0.4	0.9	1.4	1.2	A	100-C09	3	6	140U-D6D3-B20	140M-C2E-B25	CLASS RK5, CC, J, or T / DLS-R-6	140M-C2E-B25
25A-E1P7N104	1.0	0.75	1.0	0.75	1.7	2.6	2.3	A	100-C09	3	6	140U-D6D3-B30	140M-C2E-B25	CLASS RK5, CC, J, or T / DLS-R-6	140M-C2E-B25
25A-E3P0N104	2.0	1.5	2.0	1.5	3.0	4.3	3.8	A	100-C09	6	10	140U-D6D3-B50	140M-C2E-B40	CLASS RK5, CC, J, or T / DLS-R-10	140M-C2E-B40
25A-E4P2N104	3.0	2.2	3.0	2.2	4.2	6.1	5.3	A	100-C09	10	15	140U-D6D3-B80	140M-C2E-B63	CLASS RK5, CC, J, or T / DLS-R-15	140M-D8E-B63
25A-E6P6N104	5.0	4.0	5.0	4.0	6.6	9.1	8.0	B	100-C09	10	20	140U-D6D3-C10	140M-C2E-C10	CLASS RK5, CC, J, or T / DLS-R-20	140M-D8E-C10
25A-E9P9N104	7.5	5.5	7.5	5.5	9.9	12.8	11.2	C	100-C16	15	25	140U-D6D3-C15	140M-C2E-C16	CLASS RK5, CC, J, or T / DLS-R-25	140M-D8E-C16 <sup>(6)</sup>
25A-E012N104	10.0	7.5	10.0	7.5	12.0	15.4	13.5	C	100-C23	20	30	140U-D6D3-C20	140M-C2E-C16	CLASS RK5, CC, J, or T / DLS-R-30	140M-D8E-C16
25A-E019N104	15.0	11.0	15.0	11.0	19.0	27.4	24.0	D	100-C30	30	50	140U-H6C3-C30	140M-F8E-C25	CLASS CC, J, or T / 50	—
25A-E022N104	20.0	15.0	20.0	15.0	22.0	31.2	27.3	D	100-C30	35	60	140U-H6C3-C35	140M-F8E-C32	CLASS CC, J, or T / 60	—
25A-E027N104	25.0	18.5	25.0	18.5	27.0	35.4	31.2	E	100-C30	35	50	140U-H6C3-C35	140M-F8E-C32	CLASS CC, J, or T / 50	—
25A-E032N104	30.0	22.0	30.0	22.0	32.0	43.4	39.2	E	100-C37	40	60	140U-H6C3-C50	140M-F8E-C32	CLASS CC, J, or T / 60	—

(1) Normal and Heavy Duty ratings are available for this drive

(2) When the drive is controlling motors with lower amp ratings, refer to the drive nameplate for drive input current rating.

(3) The AIC ratings of the Bulletin 140M Motor Protector Circuit Breakers may vary. See See [Bulletin 140M Motor Protection Circuit Breakers Application Ratings](#).

(4) Bulletin 140M with adjustable current range should have the current trip set to the minimum range that the device will not trip.

(5) Manual Self-Protected (Type-E) Combination Motor Controller, UL listed for 480V/277 and 600V/347 AC input. Not UL listed for use on 480V or 600V Delta/Delta, corner ground, or high-resistance ground systems.

(6) When used with the 140M circuit breaker, the 25A-E9P9104 must be installed in a ventilated or non-ventilated enclosure with the minimum size of 457.2 x 269.8 mm (18 x 18 x 10.62 in.).

## Fuses and Circuit Breakers for PowerFlex 525

### 100...120V 1-Phase Input Protection Devices – Frames A...B

Catalog No.	Output Ratings					Input Ratings			IEC (Non-UL Applications)			UL Applications		
	Normal Duty		Heavy Duty		Max Amps <sup>(1)</sup>	kVA	Max Rating	Fuses		Circuit Breakers		Fuses (Max. Rating)		Circuit Breakers
	HP	kW	HP	kW				Min. Rating	140U	140M	Class / Catalog No.	140U	140M <sup>(2)(3)(4)</sup>	
25B-V2P5N104	0.5	0.4	0.5	0.4	2.5	1.3	9.6	A	100-C12	140U-D6D2-C12	140M-CZE-C10	CLASS RK5, CC, J, or T / DLS-R-20	140U-D6D2-C12	140M-CZE-C10
25B-V4P8N104	1.0	0.75	1.0	0.75	4.8	2.5	19.2	B	100-C23	140U-D6D2-C25	140M-D8E-C20	CLASS RK5, CC, J, or T / DLS-R-40	140U-D6D2-C25	140M-D8E-C20
25B-V6P0N104	1.5	1.1	1.5	1.1	6.0	3.2	24.0	B	100-C23	140U-D6D2-C30	140M-F8E-C25	CLASS RK5, CC, J, or T / DLS-R-50	140U-D6D2-C30	140M-F8E-C25

### 200...240V 1-Phase Input Protection Devices – Frames A...B

Catalog No.	Output Ratings					Input Ratings			IEC (Non-UL Applications)			UL Applications				
	Normal Duty		Heavy Duty		Max Amps <sup>(1)</sup>	kVA	Max Rating	Frame Size	Contactor Catalog No.	Fuses		Circuit Breakers		Fuses (Max. Rating)		Circuit Breakers
	HP	kW	HP	kW						Min. Rating	140U	140M	Class / Catalog No.	140U	140M <sup>(2)(3)(4)</sup>	
25B-A2P5N104	0.5	0.4	0.5	0.4	2.5	1.7	6.5	A	100-C09	10	15	140U-D6D2-C10	140M-CZE-C10	CLASS RK5, CC, J, or T / DLS-R-15	140U-D6D2-C10	140M-CZE-C10
25B-A2P5N114	0.5	0.4	0.5	0.4	2.5	1.7	6.5	A	100-C09	10	15	140U-D6D2-C10	140M-CZE-C10	CLASS RK5, CC, J, or T / DLS-R-15	140U-D6D2-C10	140M-CZE-C10
25B-A4P8N104	1.0	0.75	1.0	0.75	4.8	2.8	10.7	A	100-C12	15	25	140U-D6D2-C15	140M-CZE-C16	CLASS RK5, CC, J, or T / DLS-R-25	140U-D6D2-C15	140M-CZE-C16
25B-A4P8N114	1.0	0.75	1.0	0.75	4.8	2.8	10.7	A	100-C12	15	25	140U-D6D2-C15	140M-CZE-C16	CLASS RK5, CC, J, or T / DLS-R-25	140U-D6D2-C15	140M-CZE-C16
25B-A8P0N104	2.0	1.5	2.0	1.5	8.0	4.8	18.0	B	100-C23	25	40	140U-D6D2-C25	140M-F8E-C25	CLASS CC, J, or T / 40	140U-D6D2-C25	140M-F8E-C25
25B-A8P0N114	2.0	1.5	2.0	1.5	8.0	4.8	18.0	B	100-C23	25	40	140U-D6D2-C25	140M-F8E-C25	CLASS CC, J, or T / 40	140U-D6D2-C25	140M-F8E-C25
25B-A011N104	3.0	2.2	3.0	2.2	11.0	6.0	22.9	B	100-C37	30	50	140U-H6C2-C35	140M-F8E-C25	CLASS CC, J, or T / 50	140U-H6C2-C35	140M-F8E-C25
25B-A011N114	3.0	2.2	3.0	2.2	11.0	6.0	22.9	B	100-C37	30	50	140U-H6C2-C35	140M-F8E-C25	CLASS CC, J, or T / 50	140U-H6C2-C35	140M-F8E-C25

- (1) When the drive is controlling motors with lower amp ratings, refer to the drive nameplate for drive input current rating.
- (2) The AIC ratings of the Bulletin 140M Motor Protector Circuit Breakers may vary. See See [Bulletin 140M Motor Protection Circuit Breakers Application Ratings](#).
- (3) Bulletin 140M with adjustable current ranges should have the current trip set to the minimum range that the device will not trip.
- (4) Manual Self-Protected (Type E) Combination Motor Controller, UL listed for 480V/277 and 600V/347 AC input. Not UL listed for use on 480V or 600V Delta/Delta, corner ground, or high-resistance ground systems.



## Fuses and Circuit Breakers for PowerFlex 525 (continued)

### 200...240V 3-Phase Input Protection Devices – Frames A...E

Catalog No. <sup>(1)</sup>	Output Ratings					Input Ratings			IEC (Non-UL Applications)			UL Applications				
	Normal Duty		Heavy Duty			kVA	Max Amps <sup>(2)</sup>	Frame Size	Contactor Catalog No.	Fuses		Circuit Breakers		Fuses (Max. Rating)		
	HP	kW	HP	kW	Amps					Min. Rating	Max. Rating	140U	140M	Class / Catalog No.	140U	140M <sup>(3)(4)(5)</sup>
25B-B2P5N104	0.5	0.4	0.5	0.4	2.5	1.2	2.7	A	100-C07	6	6	140U-D6D3-B40	140M-C2E-B40	CLASS RK5, CC, J, or T / DLS-R-6	140U-D6D3-B40	140M-C2E-B40
25B-B3P0N104	1.0	0.75	1.0	0.75	5.0	2.7	5.8	A	100-C09	10	15	140U-D6D3-B80	140M-C2E-B63	CLASS RK5, CC, J, or T / DLS-R-15	140U-D6D3-B80	140M-C2E-B63
25B-B8P0N104	2.0	1.5	2.0	1.5	8.0	4.3	9.5	A	100-C12	15	20	140U-D6D3-C10	140M-C2E-C10	CLASS RK5, CC, J, or T / DLS-R-20	140U-D6D3-C10	140M-C2E-C10
25B-B017N104	3.0	2.2	3.0	2.2	11.0	6.3	13.8	A	100-C23	20	30	140U-D6D3-C15	140M-C2E-C16	CLASS RK5, CC, J, or T / DLS-R-30	140U-D6D3-C15	140M-C2E-C16
25B-B017N104	5.0	4.0	5.0	4.0	17.5	9.6	21.1	B	100-C23	30	45	140U-D6D3-C25	140M-F8E-C25	CLASS CC, J, or T / 45	140U-D6D3-C25	140M-F8E-C25
25B-B024N104	7.5	5.5	7.5	5.5	24.0	12.2	26.6	C	100-C37	35	60	140U-H6C3-C35	140M-F8E-C32	CLASS CC, J, or T / 60	140U-H6C3-C35	140M-F8E-C32
25B-B032N104	10.0	7.5	10.0	7.5	32.2	15.9	34.8	D	100-C43	45	70	140U-H6C3-C60	140M-F8E-C45	CLASS RK5, CC, J, or T / DLS-R-70	–	140M-F8E-C45
25B-B048N104	15.0	11.0	10.0	7.5	48.3	20.1	44.0	E	100-C60	60	90	140U-H6C3-C70	140M-F8E-C45	CLASS CC, J, or T / 90	–	–
25B-B062N104	20.0	15.0	15.0	11.0	62.1	25.6	56.0	E	100-C72	70	125	140U-H6C3-C90	140M-H8P-C70	CLASS CC, J, or T / 125	–	–

(1) Normal and Heavy Duty ratings are available for this drive.

(2) When the drive is controlling motors with lower amp ratings, refer to the drive nameplate for drive input current rating.

(3) The AIC ratings of the Bulletin 140M Motor Protector Circuit Breakers may vary. See See [Bulletin 140M Motor Protection Circuit Breakers Application Ratings](#).

(4) Bulletin 140M with adjustable current ranges should have the current trip set to the minimum range that the device will not trip.

(5) Manual Self-Protected (Type E) Combination Motor Controller, UL listed for 480V/277 and 600V/347 AC input. Not UL listed for use on 480V or 600V Delta/Delta, corner ground, or high-resistance ground systems.

## Fuses and Circuit Breakers for PowerFlex 525 (continued)

### 380...480V 3-Phase Input Protection Devices – Frames A...E

Catalog No. (1)	Output Ratings				Input Ratings			IEC (Non-UL Applications)				UL Applications				
	Normal Duty		Heavy Duty		Max kVA	Max Amps(2)	Frame Size	Contactor Catalog No.	Fuses		Circuit Breakers		Fuses (Max. Rating)		Circuit Breakers	
	HP	kW	HP	kW					Min. Rating	Max. Rating	140U	140M	Class / Catalog No.	140U	140M	Class / Catalog No.
25B-D1P4N104	0.5	0.4	0.5	0.4	1.4	1.7	1.9	A	100-C07	3	6	140U-D6D3-B30	140M-CZE-B25	CLASS RK5, CC, J, or T / DLS-R-6	140U	140M-CZE-B25
25B-D1P4N114	0.5	0.4	0.5	0.4	1.4	1.7	1.9	A	100-C07	3	6	140U-D6D3-B30	140M-CZE-B25	CLASS RK5, CC, J, or T / DLS-R-6	140U	140M-CZE-B25
25B-D2P3N104	1.0	0.75	1.0	0.75	2.3	2.9	3.2	A	100-C07	6	10	140U-D6D3-B60	140M-CZE-B40	CLASS RK5, CC, J, or T / DLS-R-10	140U	140M-CZE-B40
25B-D2P3N114	1.0	0.75	1.0	0.75	2.3	2.9	3.2	A	100-C07	6	10	140U-D6D3-B60	140M-CZE-B40	CLASS RK5, CC, J, or T / DLS-R-10	140U	140M-CZE-B40
25B-D4P0N104	2.0	1.5	2.0	1.5	4.0	5.2	5.7	A	100-C09	10	15	140U-D6D3-B60	140M-CZE-B63	CLASS RK5, CC, J, or T / DLS-R-15	140U	140M-CZE-B63
25B-D4P0N114	2.0	1.5	2.0	1.5	4.0	5.2	5.7	A	100-C09	10	15	140U-D6D3-B60	140M-CZE-B63	CLASS RK5, CC, J, or T / DLS-R-15	140U	140M-CZE-B63
25B-D6P0N104	3.0	2.2	3.0	2.2	6.0	6.9	7.5	A	100-C09	10	15	140U-D6D3-C10	140M-CZE-C10	CLASS RK5, CC, J, or T / DLS-R-15	140U	140M-CZE-C10
25B-D6P0N114	3.0	2.2	3.0	2.2	6.0	6.9	7.5	A	100-C09	10	15	140U-D6D3-C10	140M-CZE-C10	CLASS RK5, CC, J, or T / DLS-R-15	140U	140M-CZE-C10
25B-D010N104	5.0	4.0	5.0	4.0	10.5	12.6	13.8	B	100-C23	20	30	140U-D6D3-C15	140M-CZE-C16	CLASS RK5, CC, J, or T / DLS-R-30	140U	140M-CZE-C16
25B-D010N114	5.0	4.0	5.0	4.0	10.5	12.6	13.8	B	100-C23	20	30	140U-D6D3-C15	140M-CZE-C16	CLASS RK5, CC, J, or T / DLS-R-30	140U	140M-CZE-C16
25B-D013N104	7.5	5.5	7.5	5.5	13.0	14.1	15.4	C	100-C23	20	35	140U-D6D3-C25	140M-D8E-C20	CLASS CC, J, or T / 35	140U	140M-D8E-C20
25B-D013N114	7.5	5.5	7.5	5.5	13.0	14.1	15.4	C	100-C23	20	35	140U-D6D3-C25	140M-D8E-C20	CLASS CC, J, or T / 35	140U	140M-D8E-C20
25B-D017N104	10.0	7.5	10.0	7.5	17.0	16.8	18.4	C	100-C23	25	40	140U-D6D3-C25	140M-D8E-C20	CLASS CC, J, or T / 40	140U	140M-D8E-C20
25B-D017N114	10.0	7.5	10.0	7.5	17.0	16.8	18.4	C	100-C23	25	40	140U-D6D3-C25	140M-D8E-C20	CLASS CC, J, or T / 40	140U	140M-D8E-C20
25B-D024N104	15.0	11.0	15.0	11.0	24.0	24.1	26.4	D	100-C37	35	60	140U-H6C3-C40	140M-F8E-C32	CLASS CC, J, or T / 60	140U	140M-F8E-C32
25B-D024N114	15.0	11.0	15.0	11.0	24.0	24.1	26.4	D	100-C37	35	60	140U-H6C3-C40	140M-F8E-C32	CLASS CC, J, or T / 60	140U	140M-F8E-C32
25B-D030N104	20.0	15.0	20.0	15.0	30.0	30.2	33.0	D	100-C43	45	70	140U-H6C3-C50	140M-F8E-C45	CLASS CC, J, or T / 70	140U	140M-F8E-C45
25B-D030N114	20.0	15.0	20.0	15.0	30.0	30.2	33.0	D	100-C43	45	70	140U-H6C3-C50	140M-F8E-C45	CLASS CC, J, or T / 70	140U	140M-F8E-C45
25B-D037N114	25.0	18.5	20.0	15.0	37.0	30.8	33.7	E	100-C43	45	70	140U-H6C3-C50	140M-F8E-C45	CLASS CC, J, or T / 70	140U	140M-F8E-C45
25B-D043N114	30.0	22.0	25.0	18.5	43.0	35.6	38.9	E	100-C60	50	80	140U-H6C3-C60	140M-F8E-C45	CLASS CC, J, or T / 80	140U	140M-F8E-C45

- (1) Normal and Heavy Duty ratings are available for this drive.
- (2) When the drive is controlling motors with lower amp ratings, refer to the drive nameplate for drive input current rating.
- (3) The AIC ratings of the Bulletin 140M Motor Protector Circuit Breakers may vary. See [Bulletin 140M Motor Protection Circuit Breakers Application Ratings](#).
- (4) Bulletin 140M with adjustable current range should have the current trip set to the minimum range that the device will not trip.
- (5) Manual Self-Protected (Type E) Combination Motor Controller, UL listed for 480V/277 and 600V/347 AC input. Not UL listed for use on 480V or 600V Delta/Delta, corner ground, or high-resistance ground systems.

## Fuses and Circuit Breakers for PowerFlex 525 (continued)

### 525...600V 3-Phase Input Protection Devices – Frames A...E

Catalog No. <sup>(1)</sup>	Output Ratings					Input Ratings			IEC (Non-UL Applications)			UL Applications			
	Normal Duty		Heavy Duty		Max Amps <sup>(2)</sup>	Frame Size	Contactor Catalog No.	Fuses		Circuit Breakers		Fuses (Max. Rating)		Circuit Breakers	
	HP	kW	HP	kW				Amps	kVA	Min. Rating	Max. Rating	140U	140M		Class / Catalog No.
25B-E0P9N104	0.5	0.4	0.5	0.4	0.9	1.4	A	100-C09	3	6	140U-D6D3-B20	140M-C2E-B25	CLASS RK5, CC, J, or T / DLS-R-6	140U	140M-C2E-B25
25B-E1P7N104	1.0	0.75	1.0	0.75	1.7	2.6	A	100-C09	3	6	140U-D6D3-B30	140M-C2E-B25	CLASS RK5, CC, J, or T / DLS-R-6	140U	140M-C2E-B25
25B-E3P0N104	2.0	1.5	2.0	1.5	3.0	4.3	A	100-C09	6	10	140U-D6D3-B50	140M-C2E-B40	CLASS RK5, CC, J, or T / DLS-R-10	140U	140M-C2E-B40
25B-E4P2N104	3.0	2.2	3.0	2.2	4.2	6.1	A	100-C09	10	15	140U-D6D3-B80	140M-C2E-B63	CLASS RK5, CC, J, or T / DLS-R-15	140U	140M-D8E-B63
25B-E6P6N104	5.0	4.0	5.0	4.0	6.6	9.1	B	100-C09	10	20	140U-D6D3-C10	140M-C2E-C10	CLASS RK5, CC, J, or T / DLS-R-20	140U	140M-D8E-C10
25B-E9P9N104	7.5	5.5	7.5	5.5	9.9	12.8	C	100-C16	15	25	140U-D6D3-C15	140M-C2E-C16	CLASS RK5, CC, J, or T / DLS-R-25	140U	140M-D8E-C16 <sup>(6)</sup>
25B-E012N104	10.0	7.5	10.0	7.5	12.0	15.4	C	100-C23	20	30	140U-D6D3-C20	140M-C2E-C16	CLASS RK5, CC, J, or T / DLS-R-30	140U	140M-D8E-C16
25B-E019N104	15.0	11.0	15.0	11.0	19.0	27.4	D	100-C30	30	50	140U-H6C3-C30	140M-F8E-C25	CLASS CC, J, or T / 50	140U	140M-D8E-C16
25B-E022N104	20.0	15.0	20.0	15.0	22.0	31.2	D	100-C30	35	60	140U-H6C3-C35	140M-F8E-C32	CLASS CC, J, or T / 60	140U	140M-D8E-C16
25B-E027N104	25.0	18.5	25.0	18.5	27.0	36.2	E	100-C30	35	50	140U-H6C3-C35	140M-F8E-C32	CLASS CC, J, or T / 50	140U	140M-D8E-C16
25B-E032N104	30.0	22.0	25.0	18.5	32.0	33.4	E	100-C37	40	60	140U-H6C3-C50	140M-F8E-C32	CLASS CC, J, or T / 60	140U	140M-D8E-C16

- (1) ■ Normal and Heavy Duty ratings are available for this drive.
- (2) When the drive is controlling motors with lower amp ratings, refer to the drive nameplate for drive input current rating.
- (3) The AIC ratings of the Bulletin 140M Motor Protector Circuit Breakers may vary. See See [Bulletin 140M Motor Protection Circuit Breakers Application Ratings](#).
- (4) Bulletin 140M with adjustable current range should have the current trip set to the minimum range that the device will not trip.
- (5) Manual Self-Protected (Type E) Combination Motor Controller, UL listed for use on 480V/277 and 600V/347 AC input. Not UL listed for use on 480V or 600V Delta/Delta, corner ground, or high-resistance ground systems.
- (6) When used with the 140M circuit breaker, the 25B-E9P9104 must be installed in a ventilated or non-ventilated enclosure with the minimum size of 457.2 x 457.2 x 269.8 mm (18 x 18 x 10.62 in.).

## Accessories and Dimensions

### Dynamic Brake Resistors

Drive Ratings			Minimum Resistance $\Omega \pm 10\%$	Resistance $\Omega \pm 5\%$	Catalog No. <sup>(1)(2)</sup>
Input Voltage	HP	kW			
100...120V 50/60 Hz 1-Phase	0.25	0.2	56	91	AK-R2-091P500
	0.5	0.4	56	91	AK-R2-091P500
	1.0	0.75	56	91	AK-R2-091P500
	1.5	1.1	41	91	AK-R2-091P500
200...240V 50/60 Hz 1-Phase	0.25	0.2	56	91	AK-R2-091P500
	0.5	0.4	56	91	AK-R2-091P500
	1.0	0.75	56	91	AK-R2-091P500
	2.0	1.5	41	91	AK-R2-091P500
	3.0	2.2	32	47	AK-R2-047P500
200...240V 50/60 Hz 3-Phase	0.25	0.2	56	91	AK-R2-091P500
	0.5	0.4	56	91	AK-R2-091P500
	1.0	0.75	56	91	AK-R2-091P500
	2.0	1.5	41	91	AK-R2-091P500
	3.0	2.2	32	47	AK-R2-047P500
	5.0	4.0	18	47	AK-R2-047P500
	7.5	5.5	16	30	AK-R2-030P1K2
	10.0	7.5	14	30	AK-R2-030P1K2
	15.0	11.0	14	15	AK-R2-030P1K2 <sup>(3)</sup>
	20.0	15.0	10	15	AK-R2-030P1K2 <sup>(3)</sup>
380...480V 50/60 Hz 3-Phase	0.5	0.4	89	360	AK-R2-360P500
	1.0	0.75	89	360	AK-R2-360P500
	2.0	1.5	89	360	AK-R2-360P500
	3.0	2.2	89	120	AK-R2-120P1K2
	5.0	4.0	47	120	AK-R2-120P1K2
	7.5	5.5	47	120	AK-R2-120P1K2
	10.0	7.5	47	120	AK-R2-120P1K2
	15.0	11.0	43	60	AK-R2-120P1K2 <sup>(3)</sup>
	20.0	15.0	43	60	AK-R2-120P1K2 <sup>(3)</sup>
	25.0	18.5	27	40	AK-R2-120P1K2 <sup>(4)</sup>
	30.0	22.0	27	40	AK-R2-120P1K2 <sup>(4)</sup>
525...600V 50/60 Hz 3-Phase	0.5	0.4	112	360	AK-R2-360P500
	1.0	0.75	112	360	AK-R2-360P500
	2.0	1.5	112	360	AK-R2-360P500
	3.0	2.2	112	120	AK-R2-120P1K2
	5.0	4.0	86	120	AK-R2-120P1K2
	7.5	5.5	59	120	AK-R2-120P1K2
	10.0	7.5	59	120	AK-R2-120P1K2
	15.0	11.0	59	60	AK-R2-120P1K2 <sup>(3)</sup>
	20.0	15.0	59	60	AK-R2-120P1K2 <sup>(3)</sup>
	25.0	18.5	53	60	AK-R2-120P1K2 <sup>(3)</sup>
	30.0	22.0	34	40	AK-R2-120P1K2 <sup>(4)</sup>

(1) The resistors listed in this tables are rated for 5% duty cycle.

(2) Use of Rockwell Automation resistors is always recommended. The resistors listed have been carefully selected for optimizing performance in a variety of applications. Alternative resistors may be used, however, care must be taken when making a selection. See the PowerFlex Dynamic Braking Resistor Calculator, publication [PFLX-AT001](#).

(3) Requires two resistors wired in parallel.

(4) Requires three resistors wired in parallel.

## EMC Line Filters

Drive Ratings				Frame Size	Catalog No.
Input Voltage	HP	kW	Current (A)		
100...120V 50/60 Hz 1-Phase	0.25	0.2	1.6	A	25-RF011-AL
	0.5	0.4	2.5	A	25-RF011-AL
	1.0	0.75	4.8	B	25-RF023-BL
	1.5	1.1	6.0	B	25-RF023-BL
200...240V 50/60 Hz 1-Phase	0.25	0.2	1.6	A	25-RF011-AL
	0.5	0.4	2.5	A	25-RF011-AL
	1.0	0.75	4.8	A	25-RF011-AL
	2.0	1.5	8.0	B	25-RF023-BL
	3.0	2.2	11.0	B	25-RF023-BL
200...240V 50/60 Hz 3-Phase	0.25	0.2	1.6	A	25-RF014-AL
	0.5	0.4	2.5	A	25-RF014-AL
	1.0	0.75	5.0	A	25-RF014-AL
	2.0	1.5	8.0	A	25-RF014-AL
	3.0	2.2	11.0	A	25-RF014-AL
	5.0	4.0	17.5	B	25-RF021-BL
	7.5	5.5	24.0	C	25-RF027-CL
	10.0	7.5	32.2	D	25-RF035-DL
	15.0	11.0	48.3	E	25-RF056-EL
380...480V 50/60 Hz 3-Phase	0.5	0.4	1.4	A	25-RF7P5-AL
	1.0	0.75	2.3	A	25-RF7P5-AL
	2.0	1.5	4.0	A	25-RF7P5-AL
	3.0	2.2	6.0	A	25-RF7P5-AL
	5.0	4.0	10.5	B	25-RF014-BL
	7.5	5.5	13.0	C	25-RF018-CL
	10.0	7.5	17.0	C	25-RF018-CL
	15.0	11.0	24.0	D	25-RF033-DL
	20.0	15.0	30.0	D	25-RF033-DL
	25.0	18.5	37.0	E	25-RF039-EL
	30.0	22.0	43.0	E	25-RF039-EL <sup>(1)</sup>
	525...600V 50/60 Hz 3-Phase	0.5	0.4	0.9	A
1.0		0.75	1.7	A	25-RF8P0-BL <sup>(2)</sup>
2.0		1.5	3.0	A	25-RF8P0-BL <sup>(2)</sup>
3.0		2.2	4.2	A	25-RF8P0-BL <sup>(2)</sup>
5.0		4.0	6.6	B	25-RF8P0-BL
7.5		5.5	9.9	C	25-RF014-CL
10.0		7.5	12.0	C	25-RF014-CL
15.0		11.0	19.0	D	25-RF027-DL
20.0		15.0	22.0	D	25-RF027-DL
25.0		18.5	27.0	E	25-RF029-EL
30.0		22.0	32.0	E	25-RF029-EL <sup>(1)</sup>

(1) EMC Line Filter size is based on the input current of the drive. See the tables on [page 34](#) and [page 35](#) for more information.

(2) This 600V drive rating needs to be matched with a frame B EMC Line Filter.

**EMC Plates**

Item	Description	Frame Size	Catalog No.
EMC Plate	Optional grounding plate for shielded cables.	A	25-EMC1-FA
		B	25-EMC1-FB
		C	25-EMC1-FC
		D	25-EMC1-FD
		E	25-EMC1-FE

**Human Interface Modules (HIM) Option Kits and Accessories**

Item	Description	Catalog No.
LCD Display, Remote Panel Mount	Digital speed control CopyCat capable IP 66 (NEMA Type 4X/12) indoor use only Includes 2.9 meter cable	22-HIM-C2S
LCD Display, Remote Handheld	Digital speed control Full numeric keyboard CopyCat capable IP 30 (NEMA Type 1) Includes 1.0 m cable Panel mount with optional Bezel Kit	22-HIM-A3
Bezel Kit	Panel mount for LCD Display, Remote Handheld unit, IP 30 (NEMA Type 1) Includes 2.0 m DSI cable	22-HIM-B1
DSI HIM Cable (DSI HIM to RJ45 cable)	1.0 m (3.3 ft)	22-HIM-H10
	2.9 m (9.51 ft)	22-HIM-H30

**IP 30/NEMA 1/UL Type 1 Kit**

Item	Description	Frame Size	Catalog No.
IP 30/NEMA 1/UL Type 1 Kit	Field installed kit. Converts drive to IP 30/NEMA 1/UL Type 1 enclosure. Includes conduit box with mounting screws and plastic top panel.	A	25-JBAA
		B	25-JBAB
		C	25-JBAC
		D	25-JBAD
		E	25-JBAE

**Control Module Fan Kit**

Item	Description	Frame Size	Catalog No.
Control Module Fan Kit	For use with drive in environments with ambient temperatures up to 70 °C or horizontal mounting.	A...D	25-FAN1-70C
		E	25-FAN2-70C

**Incremental Encoder Input Option**

Item	Description	Catalog No.
Incremental Encoder	Incremental encoder input option board.	25-ENC-1

**Bulletin 160 to PowerFlex 520-Series Mounting Adapter Plate**

Item	Description	B160 Frame Size	Catalog No.
Mounting Adapter Plate	For use with drive when replacing Bulletin 160 drives in existing installations to a PowerFlex 520-Series drive. Select the catalog number based on the frame size of your Bulletin 160 drive.	A	25-MAP-FA
		B	25-MAP-FB

## Replacement Parts

### PowerFlex 520-Series Power Module

Item	Description
PowerFlex 520-Series Power Module	Replacement power module for use with PowerFlex 520-Series drives. Includes: <ul style="list-style-type: none"> <li>• Power Module</li> <li>• Power Module Front Cover</li> <li>• Power Terminal Guard</li> <li>• Heatsink Fan</li> </ul>

Output Ratings					Output Current (A)	Input Voltage Range	Frame Size	Catalog No.
Normal Duty		Heavy Duty						
HP	kW	HP	kW					
<b>100...120V AC (-15%, +10%) – 1-Phase Input, 0...230V 3-Phase Output</b>								
0.25	0.2	0.25	0.2	1.6	85...132	A	25-PM1-V1P6	
0.5	0.4	0.5	0.4	2.5	85...132	A	25-PM1-V2P5	
1.0	0.75	1.0	0.75	4.8	85...132	B	25-PM1-V4P8	
1.5	1.1	1.5	1.1	6.0	85...132	B	25-PM1-V6P0	
<b>200...240V AC (-15%, +10%) – 1-Phase Input, 0...230V 3-Phase Output</b>								
0.25	0.2	0.25	0.2	1.6	170...264	A	25-PM1-A1P6	
0.5	0.4	0.5	0.4	2.5	170...264	A	25-PM1-A2P5	
1.0	0.75	1.0	0.75	4.8	170...264	A	25-PM1-A4P8	
2.0	1.5	2.0	1.5	8.0	170...264	B	25-PM1-A8P0	
3.0	2.2	3.0	2.2	11.0	170...264	B	25-PM1-A011	
<b>200...240V AC (-15%, +10%) – 1-Phase Input with EMC Filter, 0...230V 3-Phase Output</b>								
0.25	0.2	0.25	0.2	1.6	170...264	A	25-PM2-A1P6	
0.5	0.4	0.5	0.4	2.5	170...264	A	25-PM2-A2P5	
1.0	0.75	1.0	0.75	4.8	170...264	A	25-PM2-A4P8	
2.0	1.5	2.0	1.5	8.0	170...264	B	25-PM2-A8P0	
3.0	2.2	3.0	2.2	11.0	170...264	B	25-PM2-A011	
<b>200...240V AC (-15%, +10%) – 3-Phase Input, 0...230V 3-Phase Output</b>								
0.25	0.2	0.25	0.2	1.6	170...264	A	25-PM1-B1P6	
0.5	0.4	0.5	0.4	2.5	170...264	A	25-PM1-B2P5	
1.0	0.75	1.0	0.75	5.0	170...264	A	25-PM1-B5P0	
2.0	1.5	2.0	1.5	8.0	170...264	A	25-PM1-B8P0	
3.0	2.2	3.0	2.2	11.0	170...264	A	25-PM1-B011	
5.0	4.0	5.0	4.0	17.5	170...264	B	25-PM1-B017	
7.5	5.5	7.5	5.5	24.0	170...264	C	25-PM1-B024	
10.0	7.5	10.0	7.5	32.2	170...264	D	25-PM1-B032	
15.0	11.0	10.0	7.5	48.3	170...264	E	25-PM1-B048	
20.0	15.0	15.0	11.0	62.1	170...264	E	25-PM1-B062	
<b>380...480V AC (-15%, +10%) – 3-Phase Input, 0...460V 3-Phase Output</b>								
0.5	0.4	0.5	0.4	1.4	323...528	A	25-PM1-D1P4	
1.0	0.75	1.0	0.75	2.3	323...528	A	25-PM1-D2P3	
2.0	1.5	2.0	1.5	4.0	323...528	A	25-PM1-D4P0	
3.0	2.2	3.0	2.2	6.0	323...528	A	25-PM1-D6P0	
5.0	4.0	5.0	4.0	10.5	323...528	B	25-PM1-D010	
7.5	5.5	7.5	5.5	13.0	323...528	C	25-PM1-D013	
10.0	7.5	10.0	7.5	17.0	323...528	C	25-PM1-D017	
15.0	11.0	15.0	11.0	24.0	323...528	D	25-PM1-D024	
20.0	15.0	15.0	11.0	30.0	323...528	D	25-PM1-D030	

Output Ratings					Output Current (A)	Input Voltage Range	Frame Size	Catalog No.
Normal Duty		Heavy Duty						
HP	kW	HP	kW					
<b>380...480V AC (-15%, +10%) – 3-Phase Input with EMC Filter, 0...460V 3-Phase Output</b>								
0.5	0.4	0.5	0.4	1.4	323...528	A	25-PM2-D1P4	
1.0	0.75	1.0	0.75	2.3	323...528	A	25-PM2-D2P3	
2.0	1.5	2.0	1.5	4.0	323...528	A	25-PM2-D4P0	
3.0	2.2	3.0	2.2	6.0	323...528	A	25-PM2-D6P0	
5.0	4.0	5.0	4.0	10.5	323...528	B	25-PM2-D010	
7.5	5.5	7.5	5.5	13.0	323...528	C	25-PM2-D013	
10.0	7.5	10.0	7.5	17.0	323...528	C	25-PM2-D017	
15.0	11.0	15.0	11.0	24.0	323...528	D	25-PM2-D024	
20.0	15.0	15.0	11.0	30.0	323...528	D	25-PM2-D030	
25.0	18.5	20.0	15.0	37.0	323...528	E	25-PM2-D037	
30.0	22.0	25.0	18.5	43.0	323...528	E	25-PM2-D043	
<b>525...600V AC (-15%, +10%) – 3-Phase Input, 0...575V 3-Phase Output</b>								
0.5	0.4	0.5	0.4	0.9	446...660	A	25-PM1-E0P9	
1.0	0.75	1.0	0.75	1.7	446...660	A	25-PM1-E1P7	
2.0	1.5	2.0	1.5	3.0	446...660	A	25-PM1-E3P0	
3.0	2.2	3.0	2.2	4.2	446...660	A	25-PM1-E4P2	
5.0	4.0	5.0	4.0	6.6	446...660	B	25-PM1-E6P6	
7.5	5.5	7.5	5.5	9.9	446...660	C	25-PM1-E9P9	
10.0	7.5	10.0	7.5	12.0	446...660	C	25-PM1-E012	
15.0	11.0	15.0	11.0	19.0	446...660	D	25-PM1-E019	
20.0	15.0	15.0	11.0	22.0	446...660	D	25-PM1-E022	
25.0	18.5	20.0	15.0	27.0	446...660	E	25-PM1-E027	
30.0	22.0	25.0	18.5	32.0	446...660	E	25-PM1-E032	

**PowerFlex 520-Series Control Module**

Item	Description	Frame Size	Catalog No.
PowerFlex 523 Control Module	Replacement control module for use with PowerFlex 520-Series drives. Includes: • Control Module • Control Module Front Cover	A...E	25A-CTM1
PowerFlex 525 Control Module			25B-CTM1

**Other Parts**

Item	Description	Frame Size	Catalog No.
PowerFlex 523 Control Module Front Cover	Replacement cover for the control module I/O terminals, EtherNet/IP and DSI ports.	A...E	25A-CTMFC1
PowerFlex 525 Control Module Front Cover			25B-CTMFC1
PowerFlex 520-Series Power Module Front Cover	Replacement cover for the PowerFlex 520-Series power module.	B	25-PMFC-FB
		C	25-PMFC-FC
		D	25-PMFC-FD
		E	25-PMFC-FE
PowerFlex 520-Series Power Terminal Guard	Replacement finger guard for power terminals.	A	25-PTG1-FA
		B	25-PTG1-FB
		C	25-PTG1-FC
		D	25-PTG1-FD
		E	25-PTG1-FE



**Other Parts**

Item	Description	Frame Size	Catalog No.
PowerFlex 520-Series Heatsink Fan Kit	Replacement fan for drive power module.	A	25-FAN1-FA
		B	25-FAN1-FB
		C	25-FAN1-FC
		D	25-FAN1-FD
		E	25-FAN1-FE

**Communication Option Kits and Accessories**

Item	Description	Catalog No.
Communication Adapters	Embedded communication options for use with the PowerFlex 520-Series drives: <ul style="list-style-type: none"> <li>• DeviceNet</li> <li>• Dual Port EtherNet/IP</li> <li>• PROFIBUS DP-V1</li> </ul>	25-COMM-D 25-COMM-E2P 25-COMM-P
Compact I/O Module	Three channel	1769-SM2
Universal Serial Bus™ (USB) Converter Module	Provides serial communication via DF1 protocol for use with Connected Components Workbench software. Includes: <ul style="list-style-type: none"> <li>• 2m USB cable (1)</li> <li>• 20-HIM-H10 cable (1)</li> <li>• 22-HIM-H10 cable (1)</li> </ul>	1203-USB
Serial Converter Module (RS485 to RS232)	Provides serial communication via DF1 protocol for use with Connected Components Workbench software. Includes: <ul style="list-style-type: none"> <li>• DSI to RS232 serial converter (1)</li> <li>• 1203-SFC serial cable (1)</li> <li>• 22-RJ45CBL-C20 cable (1)</li> </ul>	22-SCM-232
DSI Cable	2.0 m RJ45 to RJ45 cable, male to male connectors.	22-RJ45CBL-C20
Serial Cable	2.0 m serial cable with a locking low profile connector to connect to the serial converter and a 9-pin sub-miniature D female connector to connect to a computer.	1203-SFC
Splitter Cable	RJ45 one to two port splitter cable (Modbus only)	AK-U0-RJ45-SC1
Terminating Resistors	RJ45 120 Ohm resistors (2 pieces)	AK-U0-RJ45-TR1
Terminal Block	RJ45 Two position terminal block (5 pieces)	AK-U0-RJ45-TB2P
Connected Components Workbench Software (Download or DVD-ROM)	Windows-based software packages for programming and configuring Allen-Bradley drives and other Rockwell Automation products. Compatibility: Windows XP, Windows Vista and Windows 7	<a href="http://ab.rockwellautomation.com/programmable-controllers/connected-components-workbench-software">http://ab.rockwellautomation.com/programmable-controllers/connected-components-workbench-software</a>

**Bulletin 1321-3R Series Line Reactors**

Output Ratings <sup>(1)</sup>				Input Line Reactor <sup>(2)(3)</sup>		Output Line Reactor <sup>(2)(3)</sup>	
Normal Duty		Heavy Duty		IP 00 (Open Style)	IP 11 (NEMA/UL Type 1)	IP 00 (Open Style)	IP 11 (NEMA/UL Type 1)
HP	kW	HP	kW	Catalog No.	Catalog No.	Catalog No.	Catalog No.
<b>200...240V 50/60 Hz 1-Phase</b>							
0.25	0.2	0.25	0.2	1321-3R4-A	1321-3RA4-A	1321-3R2-D	1321-3RA2-D
0.5	0.4	0.5	0.4	1321-3R8-A	1321-3RA8-A	1321-3R2-D	1321-3RA2-D
1.0	0.75	1.0	0.75	1321-3R8-A	1321-3RA8-A	1321-3R4-A	1321-3RA4-A
2.0	1.5	2.0	1.5	1321-3R18-A	1321-3RA18-A	1321-3R8-A	1321-3RA8-A
3.0	2.2	3.0	2.2	1321-3R18-A	1321-3RA18-A	1321-3R12-A	1321-3RA12-A
<b>200...240V 50/60 Hz 3-Phase</b>							
0.25	0.2	0.25	0.2	1321-3R2-D	1321-3RA2-D	1321-3R2-D	1321-3RA2-D
0.5	0.4	0.5	0.4	1321-3R2-D	1321-3RA2-D	1321-3R2-D	1321-3RA2-D
1.0	0.75	1.0	0.75	1321-3R4-A	1321-3RA4-A	1321-3R4-A	1321-3RA4-A
2.0	1.5	2.0	1.5	1321-3R8-A	1321-3RA8-A	1321-3R8-A	1321-3RA8-A
3.0	2.2	3.0	2.2	1321-3R12-A	1321-3RA12-A	1321-3R12-A	1321-3RA12-A

**Bulletin 1321-3R Series Line Reactors**

Output Ratings <sup>(1)</sup>				Input Line Reactor <sup>(2)(3)</sup>		Output Line Reactor <sup>(2)(3)</sup>	
Normal Duty		Heavy Duty		IP 00 (Open Style)	IP 11 (NEMA/UL Type 1)	IP 00 (Open Style)	IP 11 (NEMA/UL Type 1)
HP	kW	HP	kW	Catalog No.	Catalog No.	Catalog No.	Catalog No.
5.0	4.0	5.0	4.0	1321-3R18-A	1321-3RA18-A	1321-3R18-A	1321-3RA18-A
7.5	5.5	7.5	5.5	1321-3R25-A	1321-3RA25-A	1321-3R25-A	1321-3RA25-A
10.0	7.5	10.0	7.5	1321-3R35-A	1321-3RA35-A	1321-3R35-A	1321-3RA35-A
15.0	11.0	15.0	11.0	1321-3R45-A	1321-3RA45-A	1321-3R45-A	1321-3RA45-A
20.0	15.0	15.0	11.0	1321-3R55-A (ND) 1321-3R45-A (HD)	1321-3RA55-A (ND) 1321-3RA45-A (HD)	1321-3R55-A (ND) 1321-3R45-A (HD)	1321-3RA55-A (ND) 1321-3RA45-A (HD)
<b>380...480V 50/60 Hz 3-Phase</b>							
0.5	0.4	0.5	0.4	1321-3R2-B	1321-3RA2-B	1321-3R2-B	1321-3RA2-B
1.0	0.75	1.0	0.75	1321-3R4-C	1321-3RA4-C	1321-3R4-C	1321-3RA4-C
2.0	1.5	2.0	1.5	1321-3R4-B	1321-3RA4-B	1321-3R4-B	1321-3RA4-B
3.0	2.2	3.0	2.2	1321-3R8-C	1321-3RA8-C	1321-3R8-C	1321-3RA8-C
5.0	4.0	5.0	4.0	1321-3R12-B	1321-3RA12-B	1321-3R12-B	1321-3RA12-B
7.5	5.5	7.5	5.5	1321-3R12-B	1321-3RA12-B	1321-3R12-B	1321-3RA12-B
10.0	7.5	10.0	7.5	1321-3R18-B	1321-3RA18-B	1321-3R18-B	1321-3RA18-B
15.0	11.0	15.0	11.0	1321-3R25-B	1321-3RA25-B	1321-3R25-B	1321-3RA25-B
20.0	15.0	15.0	11.0	1321-3R35-B (ND) 1321-3R25-B (HD)	1321-3RA35-B (ND) 1321-3RA25-B (HD)	1321-3R35-B (ND) 1321-3R25-B (HD)	1321-3RA35-B (ND) 1321-3RA25-B (HD)
25.0	18.5	20.0	15.0	1321-3R35-B	1321-3RA35-B	1321-3R35-B	1321-3RA35-B
30.0	22.0	25.0	18.5	1321-3R45-B (ND) 1321-3R35-B (HD)	1321-3RA45-B (ND) 1321-3RA35-B (HD)	1321-3R45-B (ND) 1321-3R35-B (HD)	1321-3RA45-B (ND) 1321-3RA35-B (HD)
<b>525...600V 50/60 Hz 3-Phase</b>							
0.5	0.4	0.5	0.4	1321-3R1-C	1321-3RA1-C	1321-3R1-C	1321-3RA1-C
1.0	0.75	1.0	0.75	1321-3R2-B	1321-3RA2-B	1321-3R2-B	1321-3RA2-B
2.0	1.5	2.0	1.5	1321-3R4-C	1321-3RA4-C	1321-3R4-C	1321-3RA4-C
3.0	2.2	3.0	2.2	1321-3R4-B	1321-3RA4-B	1321-3R4-B	1321-3RA4-B
5.0	4.0	5.0	4.0	1321-3R8-C	1321-3RA8-C	1321-3R8-C	1321-3RA8-C
7.5	5.5	7.5	5.5	1321-3R12-B	1321-3RA12-B	1321-3R12-B	1321-3RA12-B
10.0	7.5	10.0	7.5	1321-3R12-B	1321-3RA12-B	1321-3R12-B	1321-3RA12-B
15.0	11.0	15.0	11.0	1321-3R18-B	1321-3RA18-B	1321-3R18-B	1321-3RA18-B
20.0	15.0	15.0	11.0	1321-3R25-B (ND) 1321-3R18-B (HD)	1321-3RA25-B (ND) 1321-3RA18-B (HD)	1321-3R25-B (ND) 1321-3R18-B (HD)	1321-3RA25-B (ND) 1321-3RA18-B (HD)
25.0	18.5	20.0	15.0	1321-3R35-C (ND) 1321-3R25-C (HD)	1321-3RA35-C (ND) 1321-3RA25-C (HD)	1321-3R35-C (ND) 1321-3R25-C (HD)	1321-3RA35-C (ND) 1321-3RA25-C (HD)
30.0	22.0	25.0	18.5	1321-3R35-C (ND) 1321-3R25-B (HD)	1321-3RA35-C (ND) 1321-3RA25-B (HD)	1321-3R35-C (ND) 1321-3R25-B (HD)	1321-3RA35-C (ND) 1321-3RA25-B (HD)

(1) Normal Duty and Heavy Duty ratings for 15 HP (11 kW) and below are identical except for 200...240V 3-Phase 15 HP (11 kW) drive.  
 (2) Catalog numbers listed are for 3% impedance. 5% impedance reactor types are also available. See 1321 Power Conditioning Products Technical Data, publication [1321-TD001](#).  
 (3) Input line reactors were sized based on the NEC fundamental motor amps. Output line reactors were sized based on the VFD rated output currents.

### Accessory Dimensions

IP 30/NEMA 1/UL Type 1 Kit – Dimensions are in mm and (in.).

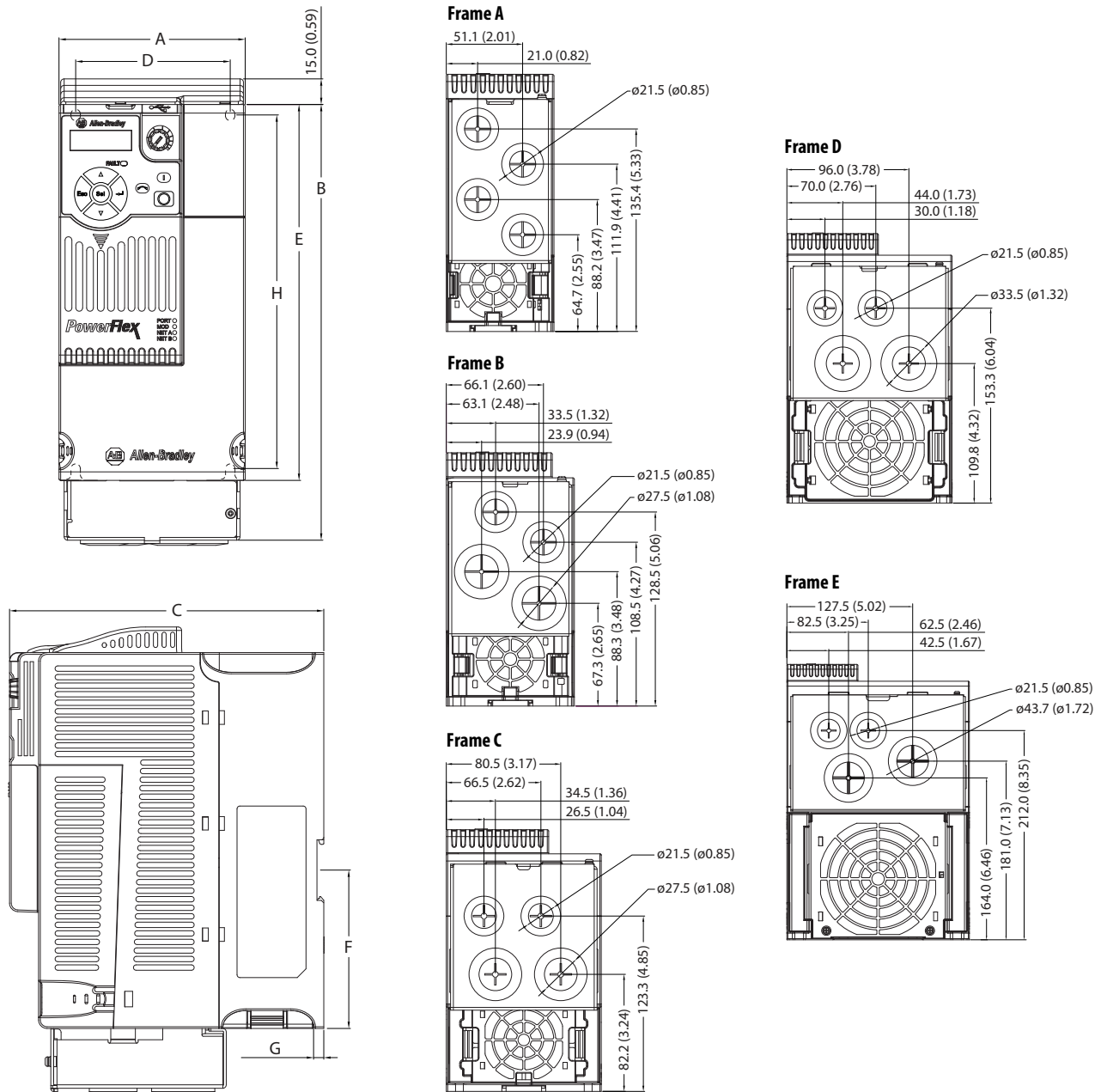

Frame Size	A	B	C	D	E	F	G	H
A	72.0 (2.83)	219.0 (8.62)	172.0 (6.77)	57.5 (2.26)	152.0 (5.98)	92.7 (3.65)	6.0 (0.24)	140.0 (5.51)
B	87.0 (3.43)	218.0 (8.58)	172.0 (6.77)	72.5 (2.85)	180.0 (7.09)	92.7 (3.65)	6.0 (0.24)	168.0 (6.61)
C	109.0 (4.29)	255.0 (10.04)	184.0 (7.24)	90.5 (3.56)	222.0 (8.66)	92.7 (3.65)	6.0 (0.24)	207.0 (8.15)
D	130.0 (5.12)	295.0 (11.61)	212.0 (8.35)	116.0 (4.57)	260.0 (10.24)	–	6.0 (0.24)	247.0 (9.74)
E	185.0 (7.28)	350.0 (13.78)	279.0 (10.98)	160.0 (6.30)	300.0 (11.81)	–	7.6 (0.30)	280.0 (11.02)

**Control Module Fan Kit – Dimensions are in mm and (in.).**

**Frame A...D**

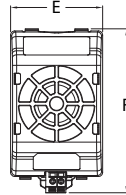
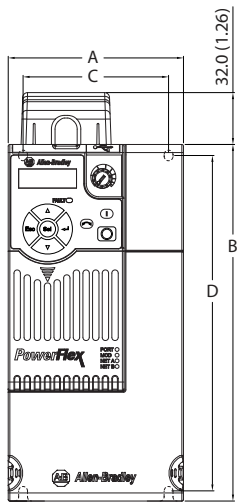

**Frame E**

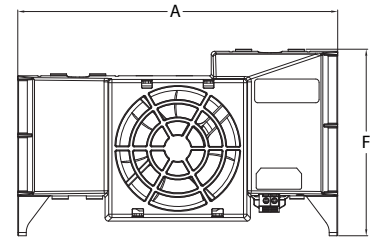
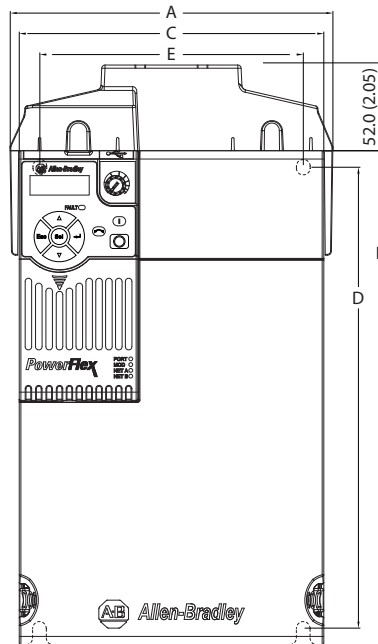

Frame Size	A	B	C	D	E	F
A	72.0 (2.83)	152.0 (5.98)	57.5 (2.26)	140.0 (5.51)	56.0 (2.20)	99.8 (3.93)
B	87.0 (3.43)	180.0 (7.09)	72.5 (2.85)	168.0 (6.61)	56.0 (2.20)	99.8 (3.93)
C	109.0 (4.29)	220.0 (8.66)	90.5 (3.56)	207.0 (8.15)	56.0 (2.20)	99.8 (3.93)
D	130.0 (5.12)	260.0 (10.24)	116.0 (4.57)	247.0 (9.72)	56.0 (2.20)	99.8 (3.93)
E	196.0 (7.72)	300.0 (11.81)	185.0 (7.28)	280.0 (11.02)	196.0 (7.72)	114.3 (4.50)

Specifications	25-FAN1-70C	25-FAN2-70C
Rated Voltage	24V DC	
Operation Voltage	14...27.6V DC	
Input Current	0.1 A	0.15 A
Speed (Reference)	7000 rpm	4500 ± 10% rpm
Maximum Air Flow (At zero static pressure)	0.575 m <sup>3</sup> /min	1.574 m <sup>3</sup> /min
Maximum Air Pressure (At zero air flow)	7.70 mmH <sub>2</sub> O	9.598 mmH <sub>2</sub> O
Acoustical Noise	40.5 dB-A	46.0 dB-A
Insulation Type	UL Class A	
Frame Size	Frame A...D	Frame E
Wire Size	0.32 mm <sup>2</sup> (22 AWG)	
Torque	0.29...0.39 Nm (2.6...3.47 lb-in.)	

**EMC Line Filter – Dimensions are in mm and (in.).**

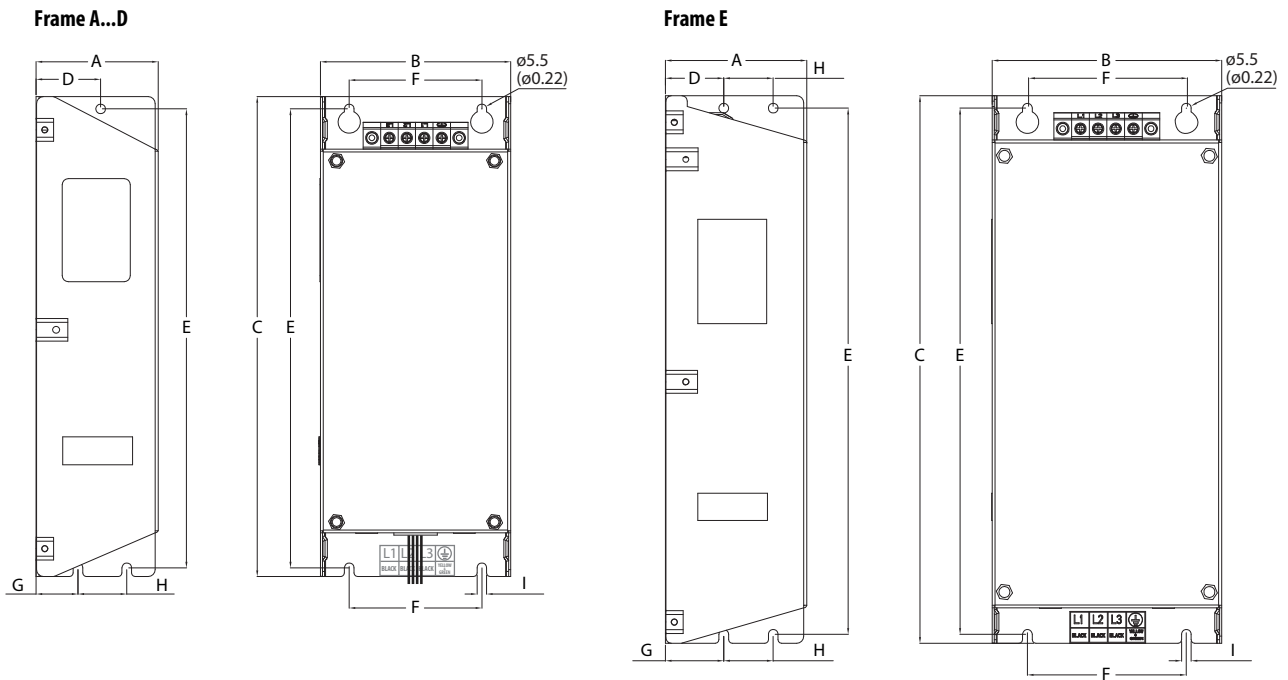

Frame Size	A	B	C	D	E	F	G	H	I
A	55.0 (2.17)	72.0 (2.83)	234.0 (9.21)	30.0 (1.18)	223.0 (8.78)	54.0 (2.13)	20.0 (0.79)	23.0 (0.91)	5.5 (0.22)
B	70.0 (2.76)	87.0 (3.43)	270.0 (10.63)	35.0 (1.38)	258.0 (10.16)	58.0 (2.28)	25.0 (0.98)	24.0 (0.94)	5.5 (0.22)
C	70.0 (2.76)	109.0 (4.29)	275.0 (10.83)	37.0 (1.46)	263.0 (10.35)	76.0 (2.99)	25.0 (0.98)	28.0 (1.10)	5.5 (0.22)
D	80.0 (3.15)	130.0 (5.12)	310.0 (12.20)	33.0 (1.30)	298.0 (11.73)	90.0 (3.54)	33.0 (1.30)	28.0 (1.10)	5.5 (0.22)
E	80.0 (3.15)	155.0 (6.10)	390.0 (15.35)	33.0 (1.30)	375.0 (14.76)	110.0 (4.33)	33.0 (1.30)	28.0 (1.10)	5.5 (0.22)

## Safe-Torque-Off Function

The PowerFlex 525 Safe-Torque-Off function, when used with other safety components, helps provide protection according to EN ISO 13849 and EN62061 for safe-off and protection against restart. The PowerFlex 525 Safe-Torque-Off function is just one component in a safety control system. Components in the system must be chosen and applied appropriately to achieve the desired level of operator safeguarding.

### PowerFlex 525 Safe-Torque-Off Overview

The PowerFlex 525 Safe-Torque-Off function:

- Provides the Safe-Torque-Off (STO) function defined in EN IEC 61800-5-2.
- Blocks gate-firing signals from reaching the Insulated Gate Bipolar Transistor (IGBT) output devices of the drive. This prevents the IGBTs from switching in the sequence necessary to generate torque in the motor.
- Can be used in combination with other safety devices to fulfill the requirements of a system “safe torque off” function which satisfies Category 3 / PL (d) according to EN ISO 13849-1 and SIL CL2 according to EN/IEC 62061, IEC 61508, and EN/IEC 61800-5-2.

### EC Type Examination Certification

TÜV Rheinland has certified the PowerFlex 525 Safe-Torque-Off function compliant with the requirements for machines defined in Annex I of the EC Directive 2006/42/EC, and that it complies with the requirements of the relevant standards listed below:

- EN ISO 13849-1:2008 Safety of machinery – Safety related parts of control systems – Part 1: General principles for design. (PowerFlex 525 STO achieves Category 3 / PL(d))
- EN 61800-5-2:2007 Adjustable speed electrical power drive systems – Part 5-2 Safety requirements – Functional. (PowerFlex 525 STO achieves SIL CL 2)
- EN 62061:2005 Safety of machinery – Functional safety of safety-related electrical, electronic and programmable electronic control systems.
- IEC 61508 Part 1-7:2010 Functional safety of electrical/electronic/programmable electronic safety-related systems – Parts 1-7.

TÜV also certifies that the PowerFlex 525 STO may be used in applications up to Category 3/ PL(d) according to EN ISO 13849-1 and SIL 2 according to EN 62061 / EN 61800-5-2 / IEC 61508.

The TÜV Rheinland certificate may be found at <http://www.rockwellautomation.com/products/certification/>.

### Safety Concept

The PowerFlex 525 Safe-Torque-Off function is suitable for use in safety applications up to and including Category 3 / PL(d) according to EN ISO 13849-1 and SIL 2 according to EN 62061 / EN 61800-5-2 / IEC 61508.

In addition, the PowerFlex 525 STO function may be used together with other components in a safety application to achieve an overall Category 3 / PL(e) according to EN ISO 13849-1 and SIL 3 according to EN 62061 and IEC 61508. This is illustrated in Example 3 on [page 50](#).

Safety requirements are based on the standards current at the time of certification.

The PowerFlex 525 STO function is intended for use in safety-related applications where the de-energized state is considered to be the safe state. All of the examples shown here are based on achieving de-energization as the safe state for typical Machine Safety and Emergency Shutdown (ESD) systems.

### *PFH and PFH Data*

PFH and PFH calculations are based on the equations from Part 6 of EN 61508.

This table provides data for a 20-year proof test interval and demonstrates the worst-case effect of various configuration changes on the data.

#### **PFH and PFH for 20-year Proof Test Interval**

<b>Attribute</b>	<b>Value</b>
PFH	6.62E-05 (MTTF = 3593 years)
PFH <sub>D</sub>	8.13E-10
SFF	83%
DC	62.5%
CAT	3
HFT	1 (1002)
PTI	20 YEARS
Hardware Type	Type A

### *Safety Reaction Time*

The safety reaction time from an input signal condition that triggers a safe stop, to the initiation of the configured Stop Type, is 100 ms (maximum).

## Connection Examples

### Example 1 – Safe-Torque-Off Connection with Coast-to-Stop Action, SIL 2/PL d

#### Stop Category 0 – Coast

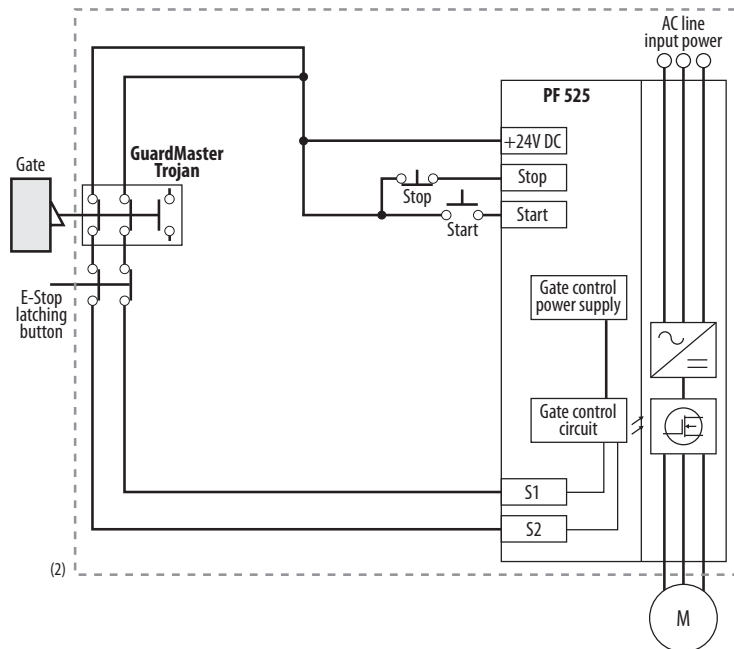
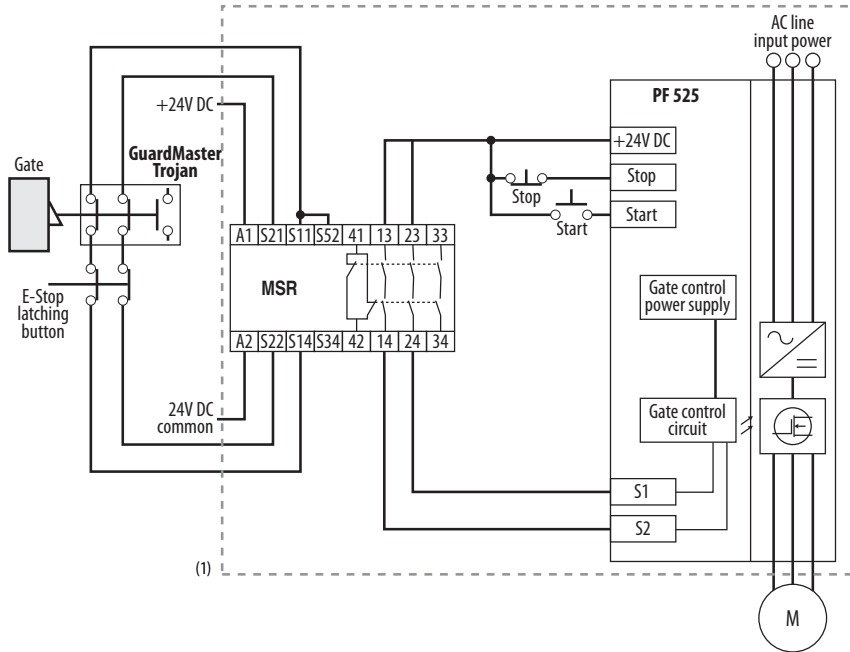

- (1) Enclosure Recommended. Note: External wiring failure modes must be considered as described in EN ISO 13849-2. Enclosure or other measure to exclude these failure modes should be used.  
 (2) In some situations, a safety relay is not required if both the switch and PowerFlex 525 are installed in the same enclosure.



**Stop Category 0 – Coast with Two PowerFlex 525 Drives**

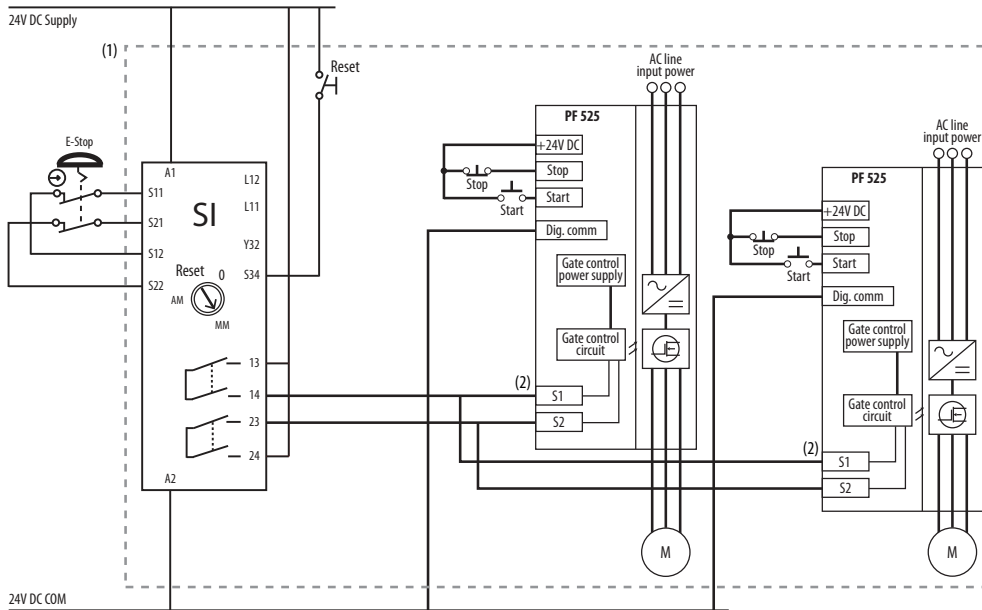

- (1) Enclosure Recommended. Note: External wiring failure modes must be considered as described in EN ISO 13849-2. Enclosure or other measure to exclude these failure modes should be used.
- (2) Each safety input draws 6 mA from the supply.

**Example 2 – Safe-Torque-Off Connection with Controlled Stop Action, SIL 2/PL d**

**Stop Category 1– Controlled**

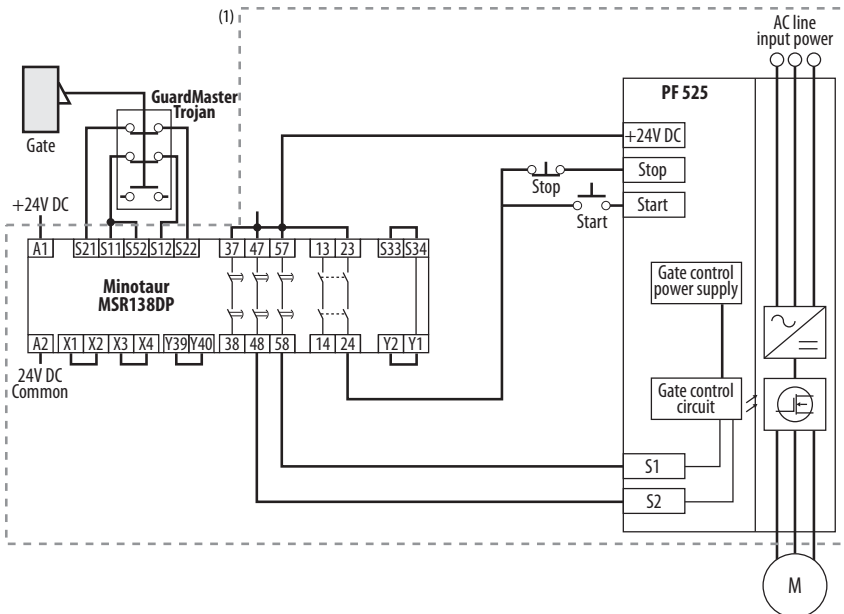

- (1) Enclosure Recommended. Note: External wiring failure modes must be considered as described in EN ISO 13849-2. Enclosure or other measure to exclude these failure modes should be used.

*Example 3 – Safe-Torque-Off Connection with Coast-to-Stop Action Using External +24V supply, SIL 3/PL e*

**Stop Category 0 – Coast**

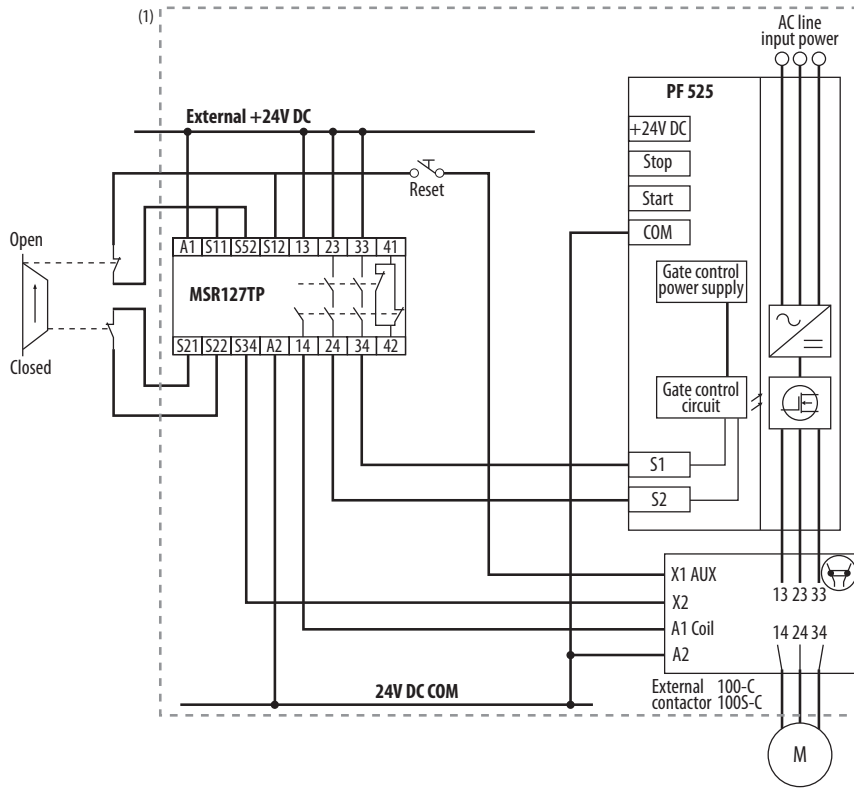

(1) Enclosure Recommended. Note: External wiring failure modes must be considered as described in EN ISO 13849-2. Enclosure or other measure to exclude these failure modes should be used.

## Additional Resources

These documents contain additional information concerning related products from Rockwell Automation.

Title	Publication
PowerFlex 520-Series Adjustable Frequency AC Drive User Manual	<a href="#">520-UM001</a>
PowerFlex 4-Class Human Interface Module (HIM) DSI Quick Reference	<a href="#">22HIM-QR001</a>
PowerFlex 525 Embedded EtherNet/IP Adapter User Manual	<a href="#">520COM-UM001</a>
PowerFlex 25-COMM-D DeviceNet Adapter User Manual	<a href="#">520COM-UM002</a>
PowerFlex 25-COMM-E2P EtherNet/IP Adapter User Manual	<a href="#">520COM-UM003</a>
PowerFlex 25-COMM-P PROFIBUS DP Adapter User Manual	<a href="#">520COM-UM004</a>
Dynamic Braking Resistor Calculator	<a href="#">PFLEX-AT001</a>
Wiring and Grounding Guidelines for PWM AC Drives	<a href="#">DRIVES-IN001</a>
Preventive Maintenance of Industrial Control and Drive System Equipment	<a href="#">DRIVES-TD001</a>
Safety Guidelines for the Application, Installation and Maintenance of Solid State Control	<a href="#">SGI-1.1</a>

You can view or download publications at <http://www.rockwellautomation.com/literature/>. To order paper copies of technical documentation, contact your local Allen-Bradley distributor or Rockwell Automation sales representative.

## Important Information

Solid-state equipment has operational characteristics differing from those of electromechanical equipment. Safety Guidelines for the Application, Installation and Maintenance of Solid State Controls (publication [SGI-1.1](#) available from your local Rockwell Automation sales office or online at <http://www.rockwellautomation.com/literature/>) describes some important differences between solid-state equipment and hard-wired electromechanical devices. Because of this difference, and also because of the wide variety of uses for solid-state equipment, all persons responsible for applying this equipment must satisfy themselves that each intended application of this equipment is acceptable.

In no event will Rockwell Automation, Inc. be responsible or liable for indirect or consequential damages resulting from the use or application of this equipment.

The examples and diagrams in this publication are included solely for illustrative purposes. Because of the many variables and requirements associated with any particular installation, Rockwell Automation, Inc. cannot assume responsibility or liability for actual use based on the examples and diagrams.

No patent liability is assumed by Rockwell Automation, Inc. with respect to use of information, circuits, equipment, or software described in this manual.

Reproduction of the contents of this manual, in whole or in part, without written permission of Rockwell Automation, Inc., is prohibited.

## Documentation Feedback

Your comments will help us serve your documentation needs better. If you have any suggestions on how to improve this document, complete this form, publication [RA-DU002](#), available at <http://www.rockwellautomation.com/literature/>.

Allen-Bradley, Rockwell Software, Rockwell Automation, PowerFlex, Connected Components Workbench, Studio 5000, DriveTools SP, AppView, CustomView, MainsFree Programming, and PointStop are trademarks of Rockwell Automation, Inc.

Trademarks not belonging to Rockwell Automation are property of their respective companies.

**[www.rockwellautomation.com](http://www.rockwellautomation.com)**

---

### Power, Control and Information Solutions Headquarters

Americas: Rockwell Automation, 1201 South Second Street, Milwaukee, WI 53204-2496 USA, Tel: (1) 414.382.2000, Fax: (1) 414.382.4444

Europe/Middle East/Africa: Rockwell Automation NV, Pegasus Park, De Kleetlaan 12a, 1831 Diegem, Belgium, Tel: (32) 2 663 0600, Fax: (32) 2 663 0640

Asia Pacific: Rockwell Automation, Level 14, Core F, Cyberport 3, 100 Cyberport Road, Hong Kong, Tel: (852) 2887 4788, Fax: (852) 2508 1846

Publication 520-TD001D-EN-E - January 2014

Supersedes Publication 520-TD001C-EN-E - September 2013

Copyright © 2014 Rockwell Automation, Inc. All rights reserved.