

CATALOG NUMBERS:  
P60-GFCI, P60GFCI-AL

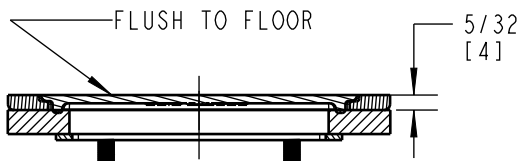
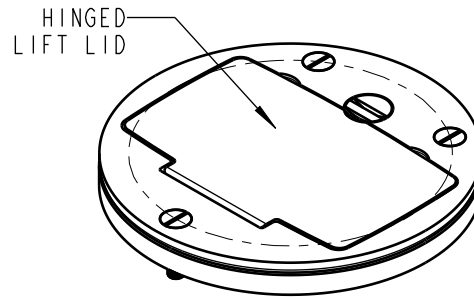
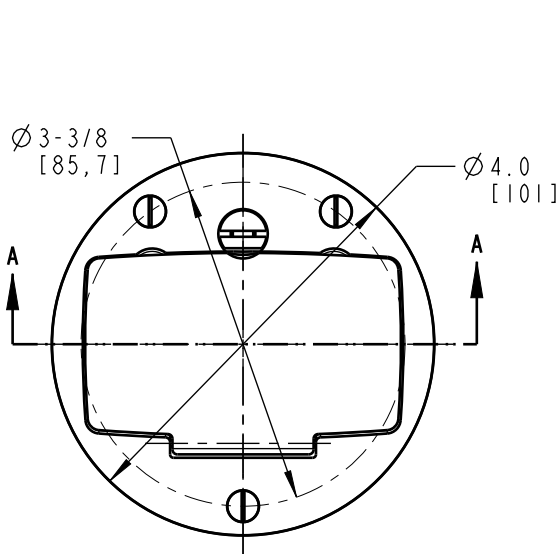

SECTION A-A

FEATURES:

1. FOR USE WITH 68P, 68 AND 600 SERIES FLOOR BOXES
2. AVAILABLE IN SOLID BRASS AND ALUMINUM MATERIAL
3. FURNISHED WITH SEALING GASKET AND MATCHING 8-32 X 7/16" FLATHEAD SCREWS

CATALOG NUMBERS	MATERIAL	FINISH
P60-GFCI	SOLID BRASS	BRASS
P60GFCI-AL	ALUMINUM	ALUMINUM

GENERAL NOTES

1. ALL DIMENSIONS ARE FOR REFERENCE ONLY.
2. DIMENSIONS IN BRACKETS [ ] ARE IN METRIC UNITS.

www.tnb.com

REVISIONS

A SEE ECN ( \*\*\*\* ) FOR APPROVAL SIGNATURES & RELEASE DATE.  
PROJECT NO: \*\*\*\*

DESCRIPTION:

**P60-GFCI, P60-GFCI-AL  
COVER PLATE, GFCI**

ORIGINAL PROJECT NO / ECN NO  
003V001056 / ECN000083908

SHEET NO:  
1 OF 1

REV. NO:  
**A**

DRAWING NO:  
**WSD-002612**

**Thomas & Betts**  
A Member of the ABB Group