

## 3 Position (Cloverleaf) Single-Phase Cutout / Arrester Bracket (15°)

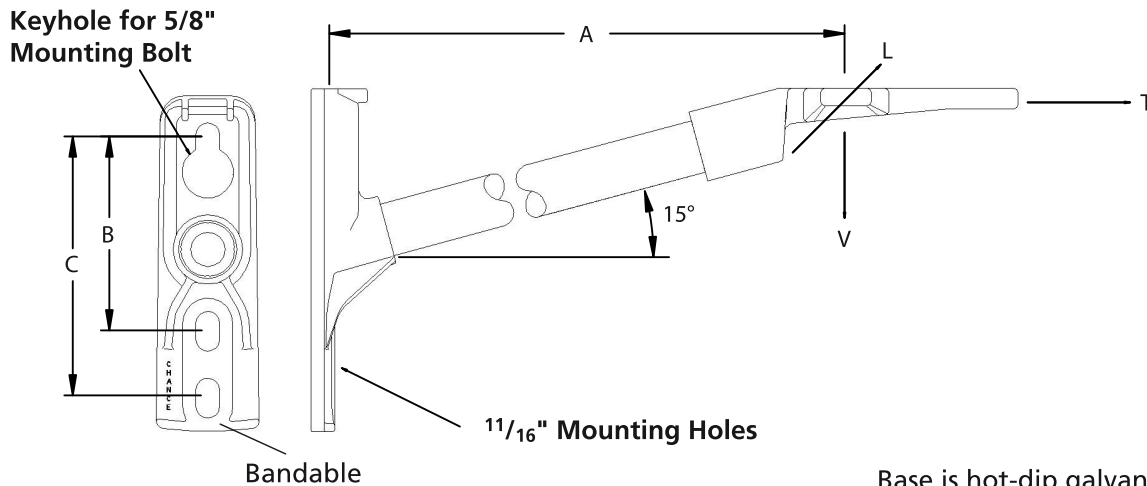
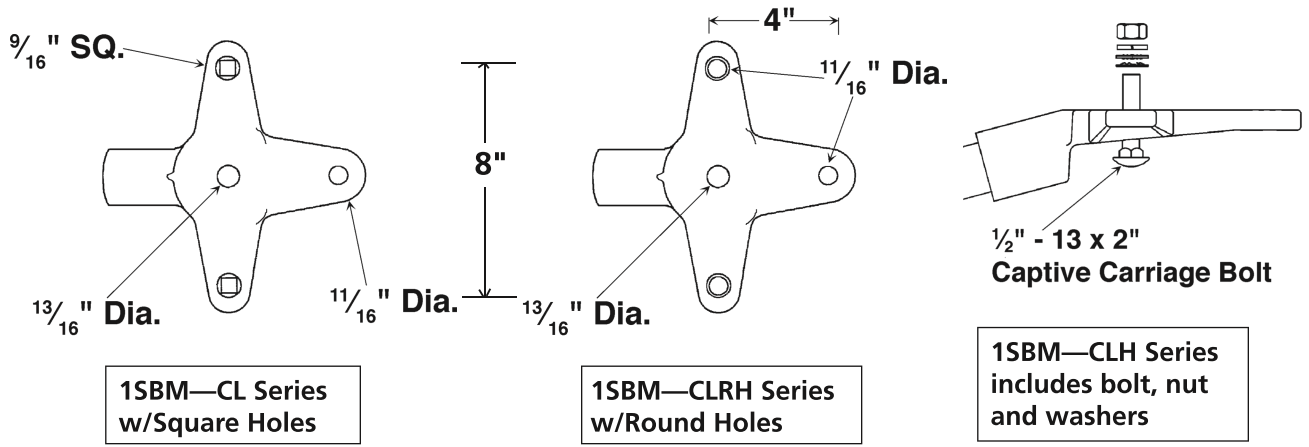

**B** Dimension is 6"  
**C** Dimension is 8"  
 RUS Accepted.

Base is hot-dip galvanized ductile iron and End Fitting is aluminum alloy.

Catalog Number	Length A	Minimum Ultimate*			Weight (Each)
		Vertical V	Longitudinal L	Transverse T	
<b>Medium Duty 1½" (38 mm) Dia. Fiberglass Rod</b>					
1SBM12CL	12" (30.5 cm)	1800 lbs. (816 kg)	1400 lbs. (635 kg)	10,000 lbs. (4536 kg)	6.6 lbs. (3.1 kg)
1SBM18CL	18" (45.7 cm)	1200 lbs. (544 kg)	950 lbs. (431 kg)	10,000 lbs. (4536 kg)	7.4 lbs. (3.4 kg)
1SBM12CLH	12" (30.5 cm)	1800 lbs. (816 kg)	1400 lbs. (635 kg)	10,000 lbs. (4536 kg)	6.6 lbs. (3.1 kg)
1SBM18CLH	18" (45.7 cm)	1200 lbs. (544 kg)	950 lbs. (431 kg)	10,000 lbs. (4536 kg)	7.4 lbs. (3.4 kg)
1SBM12CLR	12" (30.5 cm)	1800 lbs. (816 kg)	1400 lbs. (635 kg)	10,000 lbs. (4536 kg)	6.6 lbs. (3.1 kg)
1SBM18CLR	18" (45.7 cm)	1200 lbs. (544 kg)	950 lbs. (431 kg)	10,000 lbs. (4536 kg)	7.4 lbs. (3.3 kg)

\*Recommended maximum working load is 50% of minimum ultimate ratings listed.  
 Consult factory for additional lengths.  
 Add "SC" suffix to the end of the catalog number to denote Silicone Coated rod