

NUT RETAINER

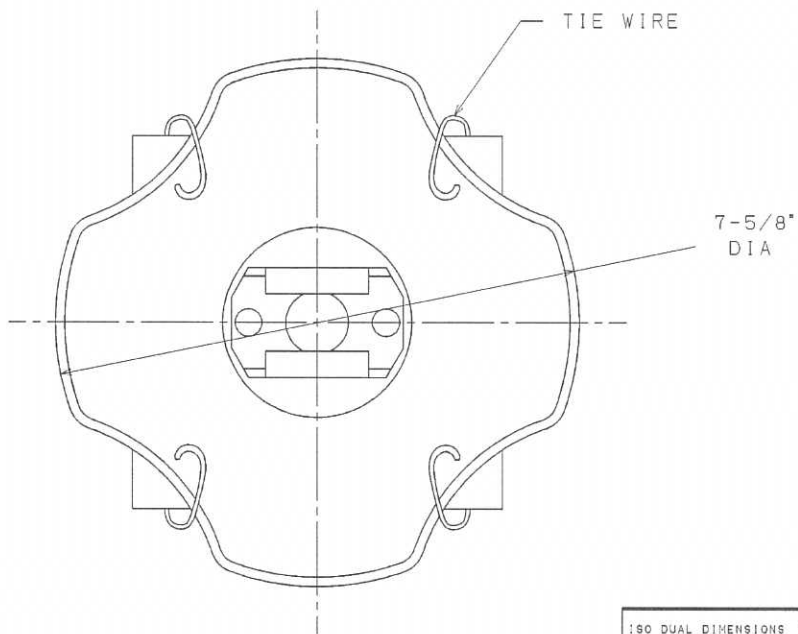

TIE WIRE

7-5/8"
DIA

CATALOG NUMBER	ANCHOR HOLE SIZE	AREA SQ. IN.	ROD SIZE
6870	6"	70	5/8"
88135	8"	135	5/8" OR 3/4"
1082	10"	200	1"
1082-3/4	10"	200	3/4"
1283	12"	300	1-1/4"
1283-1	12"	300	1"

MAT'L: STEEL, DIPPED IN BLACK ASPHALT PAINT.
ADD SUFFIX 'G' FOR GALVANIZED STEEL.

1:50 DUAL DIMENSIONS (IF ANY) IN = INCH, MM = MILLIMETER		THIRD ANGLE PROJECTION	REV.	DATE	BY	APPD
DRN.	SC	10-03-88	8-WAY EXPANDING ANCHOR			
CHK.	SC	10-03-88	HUBBELL® CHANCE® SA88135			
DSGN.	DVH	10-03-88	POWER SYSTEMS			
APPD.	JTO	10-03-88	SCALE: 1-1/8" = 1'-0"			

CONFIDENTIAL: THIS DRAWING AND ITS CONTENTS ARE CONFIDENTIAL AND THE EXCLUSIVE PROPERTY OF HUBBELL POWER SYSTEMS, A DIVISION OF HUBBELL CORPORATION. NO REPRODUCTION, DISTRIBUTION, OR DISSEMINATION OF THIS DRAWING OR ITS CONTENTS IS PERMITTED WITHOUT THE WRITTEN CONSENT OF HUBBELL POWER SYSTEMS. © 2000 HUBBELL/A. B. CHANCE. UNPUBLISHED - ALL RIGHTS RESERVED UNDER THE COPYRIGHT LAWS