



**Product Datasheet**

**ANDERSON FARGO**

**MS82S -- Suspension Clamp**



Suspension Clamp, Ductile Iron, for use with conductors 0.4 - 0.82 with fitting: Socket

**Product Specifications**

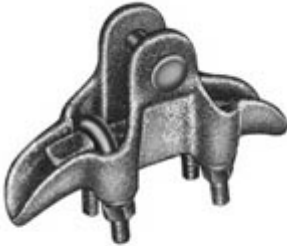
Series	 MS series Ground Wire Suspension Ductile Iron
PDF Catalog Page	<a href="#">Click HERE to view the web page.</a>
Fitting	Socket
Clamp Material	Ductile Iron
Fitting Catalog No.	SA-06
Ultimate Body Strength	18,000 lbs (8,165 kgs)
Maximum Take-off Angle 0	30
Dimension H	2.38 in (60.3 mm)
Dimension L	7.50 in (190.5 mm)
Dimension W	0.94 in (23.8 mm)
Hardware Material	Galvanized Steel
Minimum - Maximum Conductor Size	Alumoweld 7 # 7 Thru Alumoweld 19 # 10 w/Armor Rods EHS 7/16 inch str (7) Thru EHS 1/2 inch str (19) w/Armor Rods
Clamping Range	0.40 - 0.82 in (10.16 - 20.83 mm)
Material Type	Standard
UPC Code	09635932233
Standard Package	10
Standard Package Unit	Each

Min Order Qty	1
Weight / Ea.	4.606 lbs

**Compressed Product Number**

MS82S

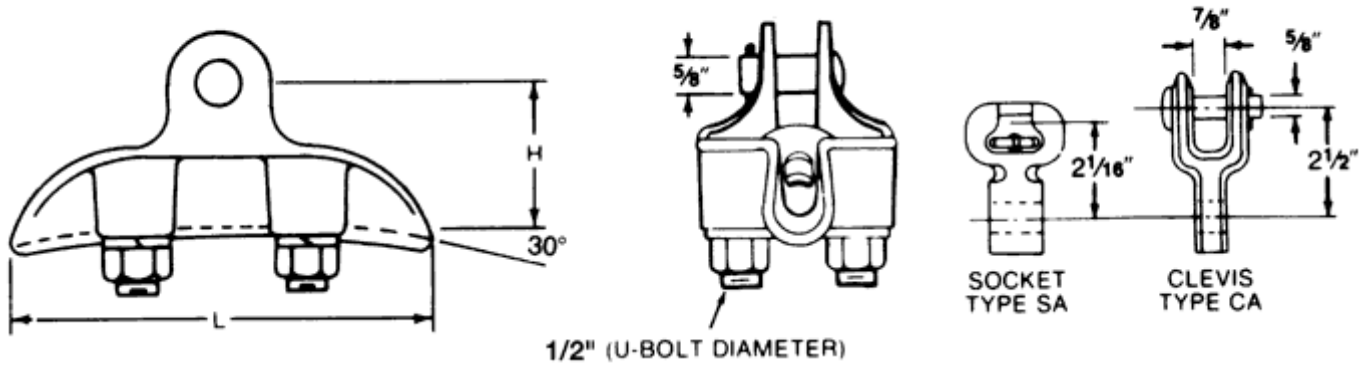

[Catalog Home](#)



[Warranty Info](#) | [Trademarks](#) | [Terms of Use](#)

All contents Copyright © 2007 Hubbell Power Systems, Inc. All rights reserved.

NOTE: Because Hubbell has a policy of continuous product improvement, we reserve the right to change design and specifications without notice.