



Self-Diagnostic Electronics Option Operating Instructions

Spectron Electronics

All Liteforms Collection models ordered with the Spectron (I) option provide:

- ❑ Visual indication of AC power status
- ❑ Visual Indication of all self-diagnostic test cycles
- ❑ Visual indication of unit malfunctions including:
 - Battery fault
 - Charger fault
 - Transfer fault
 - Lamp fault
- ❑ User initiated test cycles of 1, 5, 30 or 60 minutes
- ❑ Temperature compensated charger maximizes battery life (LT models)
- ❑ 15 minute retransfer delay (LT models)

LX, LTD Tandem Models Only

Damp Location Listed, 10°C to 40°C (50°F to 104°F)

LED Indicators

Two Status LED indicators, one red and one green are provided on the control panel of all models equipped with the Spectron option.

Red Service Alert LED

Under normal operating conditions, the Service Alert LED indicator will remain off. In the event the Spectron Controller detects a malfunction, the Service Alert LED will blink at a 1 Hz. rate based on the following table:

SERVICE ALERT CODES	
● -	= battery disconnected
● - ●	= battery fault
● - ● - ●	= charger fault
● - ● - ● - ●	= transfer fault
● - ● - ● - ● - ●	= lamp fault

Service Alert Codes	Description
One blink ON/pause	Battery not connected
Two blinks ON/pause	Battery fault
Three blinks ON/pause	Charger fault
Four blinks ON/pause	Transfer circuit fault
Five blinks ON/pause	Lamp Fault
	LX Exit
	LT Tandem
Exit Legend	✓
Lamp Head	-

Green Operating Status LED

The green Operating Status LED serves as both an AC power and a self-test indicator. During normal operation, the Operating Status LED will be illuminated indicating the presence of AC power. During all automatic or manual self-test cycles, the Operating Status LED will blink at a 1 Hz. rate.

operating status
on = ready
off = ac off
blinking = test in process

Manual Tests

Using the unit test switch, users can initiate different duration test cycles based on the following table:

Initiating Action	Test Cycle
Press test switch once	1 minute
Press test switch twice	5 minute
Press test switch 3 times	30 minute
Press test switch 4 times	60 minute

NOTE: Pressing test switch at any time after a test cycle has begun cancels remainder of test and returns unit to normal operation.

Remote Capacity Model Jumper Setting

(LT ___ 3 Tandem models only)

Liteforms Collection Remote Capacity models provide sufficient battery capacity to operate one additional 5 watt remote lighting fixture. Remote capacity models with the Spectron option are shipped from the factory with a load sensing jumper provided as shown in position "A" of the illustration below. In this position, Spectron's diagnostic circuitry can sense a failure in any of the unit's three connected lamps (2 integral and 1 remote).

IMPORTANT

If the third (remote) lighting head is not to be connected (for the purpose of extended run time or other reasons), the load sensing jumper must be reinstalled as shown in Position "B" below to prevent a false lamp failure indication.

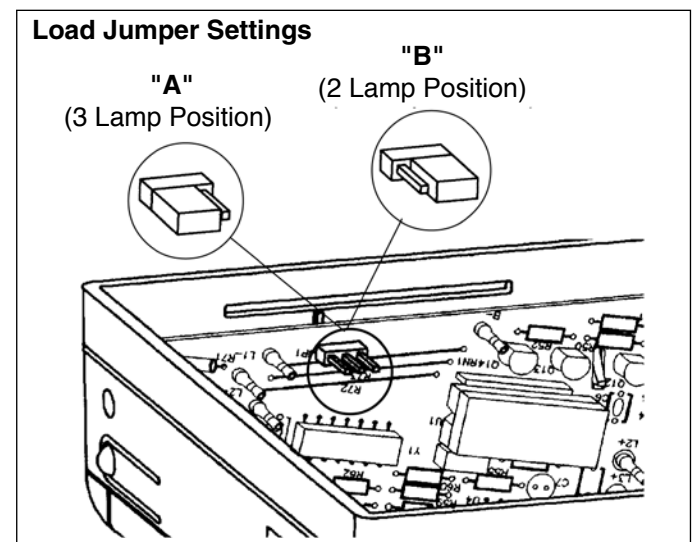



Operating Instructions (Cont.)

Operation

SPECTRON electronics operation is fully automatic. Accidental discharge of the unit battery prior to energization is prevented by an AC lockout circuit. The unit's green Operating Status LED, located on the Spectron display panel, illuminates to indicate the presence of AC power. The unit's red Service Alert LED will blink after application of AC power if the battery connection is not completed. During normal operation, the unit's charging circuit maintains the battery at full capacity and the Spectron Controller constantly monitors charger performance. Should the terminal voltage vary from design parameter values, the unit's red Service Alert LED will blink, indicating a malfunction of the battery or charger. Upon interruption of normal AC power, or brownout condition, the Spectron Controller automatically switches the emergency lighting load to the battery. Emergency power will be provided for a minimum of 90 minutes. During emergency operation, the battery is protected from deep discharge by a low voltage battery disconnect circuit. Upon return of normal AC power, a 15 minute retransfer delay holds the unit in emergency operation mode allowing utility voltage to stabilize prior to reconnection. The charger will then begin a recharge cycle. A temperature compensated float type charger is provided in LT models. This charger is designed to adjust charging voltage with changes in ambient temperature to maximize the life and performance of the unit's pure-lead type batteries. All other Liteforms Series exit signs utilize constant current type chargers which require no temperature compensation to maintain the unit's Nickel-Cadmium

batteries. All chargers will bring the unit battery to full capacity within acceptable U.L. time standards. The Spectron Controller automatically initiates a one minute discharge/diagnostic test every 28 days \pm 3.5 hours and a 30-minute discharge/diagnostic test every 6 months \pm 1 day. These tests exercise the unit's battery to optimize its capacity and allows the SPECTRON Controller to analyze emergency operation performance. Any malfunction of the unit's transfer circuit or emergency lamps will cause the red Service Alert LED on the unit's display panel to blink. During normal operation, all red Service Alert LED blinking indications of unit malfunction remain latched until corrected and retested. A manual test switch allows a user programmable 1, 5, 30 or 60-minute diagnostic/discharge test at any time. During all automatic and user initiated self-tests, the unit's green Operating Status LED will blink to indicate a diagnostic cycle in process.

Warning: This product contains chemicals known to the state of California to cause cancer, birth defects, and/or other reproductive harm. Thoroughly wash hands after installing, handling, cleaning, or otherwise touching this product.