



[Catalog Home](#)

Product Datasheet

CHANCE

DT7C1 -- BRACKET, CLUSTER-MOUNTING, WIN

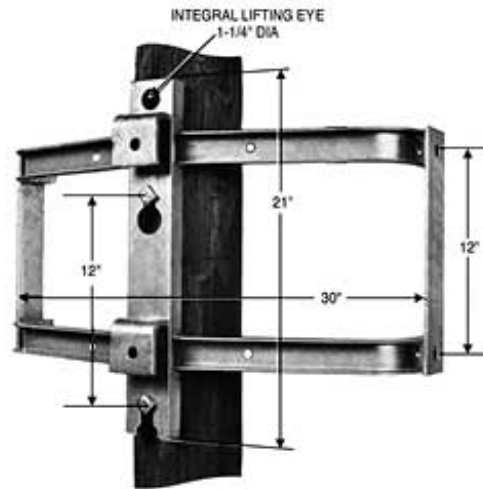

Product Specifications

Product Categories	Equipment Mounting Brackets
Product Group	Bracket, Transformer, Steel
Product Type	Bolted
Style	Welded Frame
Size	Not Applicable for Bolted Type
Diameter	Not Applicable for Bolted Type
Transformer Lug Configuration	NEMA A or B, 12" or 24" Vertical Spacing
Product Finish	Galvanized, ASTM A-153
Material	Steel
Details	Welded Frame
Dimension A	34 1/4"
Dimension B	11 1/8"
Return Type	Standard
UPC Code	096359370536
Standard Package	1
Unit of Measure	EA
Min Order Qty	1
Pallet Quantity	5
Weight / Ea.	67.62 lbs
Webpage	Click HERE to view webpage
Drawing	Click HERE to view drawing.

Compressed Product Number

DT7C1

[Catalog Home](#)



[Warranty Info](#) | [Trademarks](#) | [Terms of Use](#)

All contents Copyright © 2007 Hubbell Power Systems, Inc. All rights reserved.

NOTE: Because Hubbell has a policy of continuous product improvement, we reserve the right to change design and specifications without notice.