

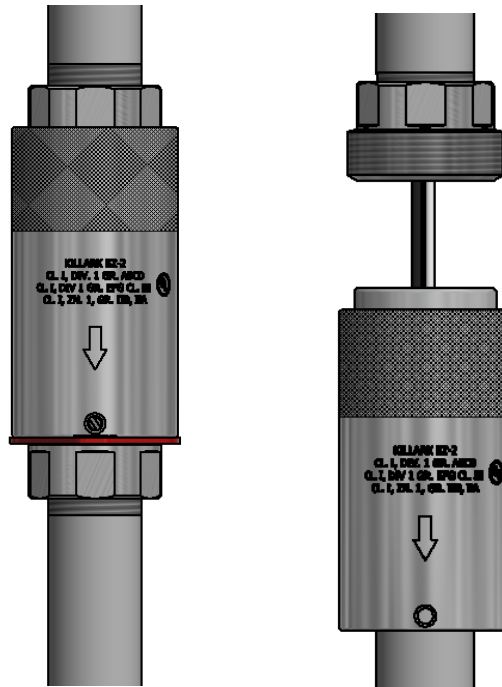

EZ SEAL

Retro Fit Installation



Cl. I Div. 1 Grp, ABCD Cl. II Div. 1 Grp, EFG  US Cl. III
--

CAUTION:

Before installing, make sure you are compliant with area classifications, as failure to do so may result in bodily injury, death and property damage. Do not attempt installation until you are familiar with the following procedures. All installation must comply with the applicable Electrical Code(s). Make sure that the circuit is de-energized before starting installation or maintenance. Verify that the installation is grounded. Failure to ground will create electrical shock hazards, which can cause serious injury and or death.

IMPORTANT:

Please read these instructions carefully before installing or maintaining this equipment. Good electrical practices should be followed at all times and this data should be used as a guide only.

Technical information, advice and recommendations contained in these documents is based upon information that Killark believes to be reliable. All the information and advice contained in these documents is intended for use only by persons having been trained and possessing the requisite skill and know-how and to be used by such persons only at their own discretion and risk. The nature of these instructions is informative only and does not cover all of the details, variations or combinations in which this equipment may be used, its storage, delivery, installation, check out, safe operation and maintenance. Since conditions of use of the product are outside of the care, custody and control of Killark, the purchaser should determine the suitability of the product for his intended use, and assumes all risk and liability whatsoever in connection there with.

EZ Seal Components

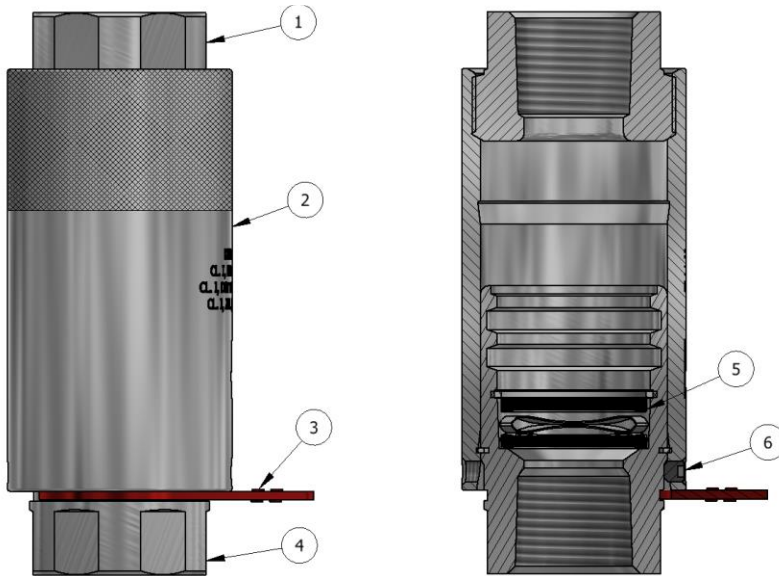

1. Top Nut
2. Coupler
3. EZ Tab
4. Potting Chamber
5. Sealing Barrier
6. Set Screw

Installation Instructions

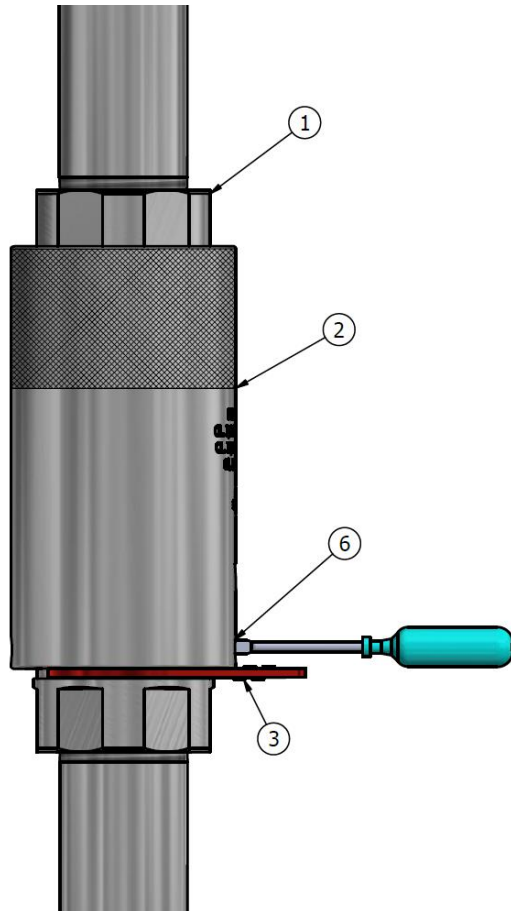

A)

- **Disconnect & de-energize any related circuits before beginning retrofit procedure.**
- **These retrofit instructions are only valid for EZ Seal to EZ Seal retrofits.**
- Use a flat head screwdriver to loosen set screw (6).
- Remove EZ Tab (3).
- Unthread coupler (2) from top nut (1) to expose potted conductors.

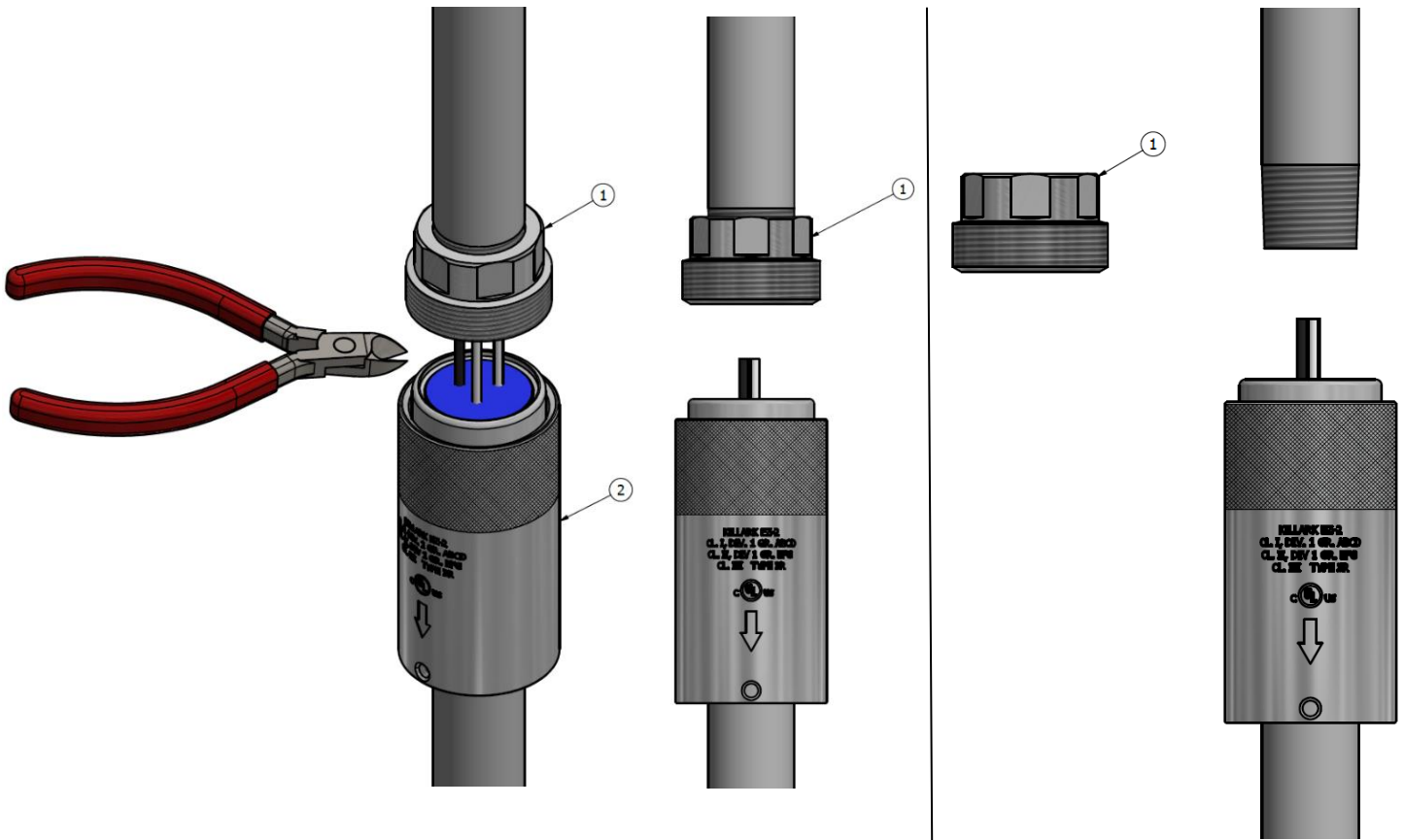

B)

- **With conductors exposed, verify circuit and conductors are disconnected & de-energized.**
- Use wire cutters to cut exposed conductors.
- Pull disconnected wires down from the top nut (1).

C)

- Remove top nut (1) from conduit.

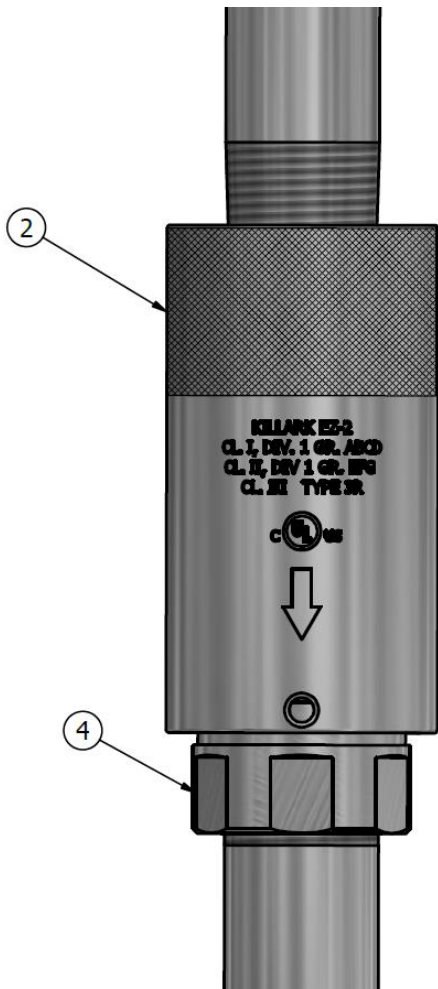

D)

- Slide the coupler (2) up to expose the flats on the potting chamber (4).
- Ensure conductors from bottom side of conduit run are disconnected and can freely move.
- Unthread potting chamber (4) from bottom conduit.

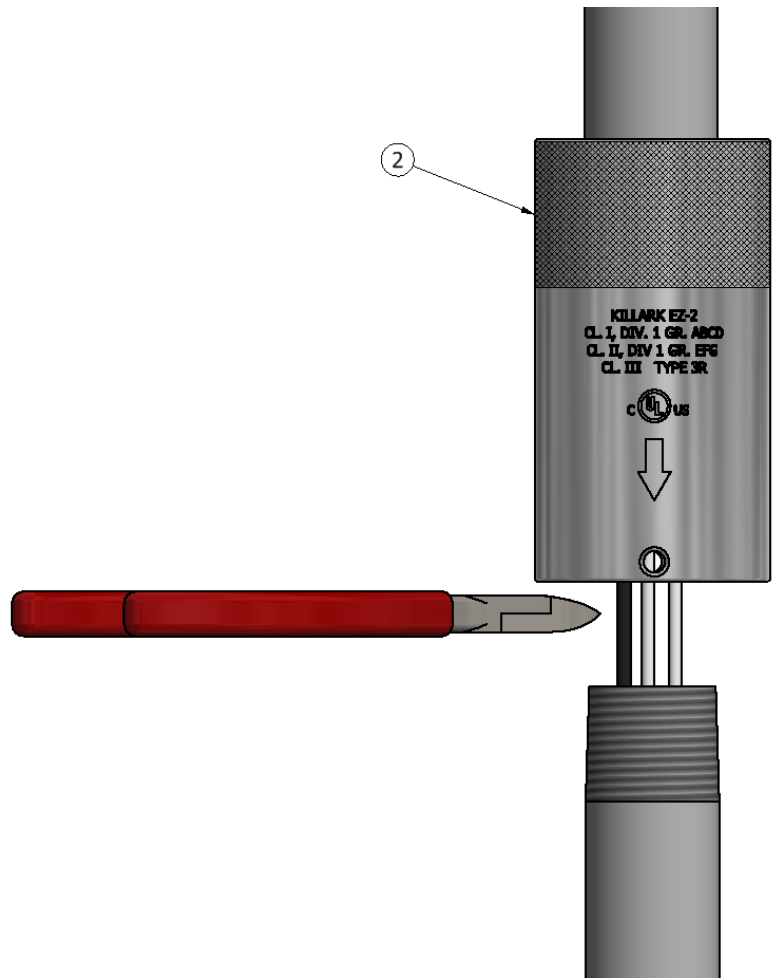

E)

- Slide the potting chamber (4) up inside of the coupler (2).
- Move the coupler (2) up towards the top conduit to expose remaining conductors.
- Cut conductors and remove from conduit run.
- Remove EZ Seal from conduit.

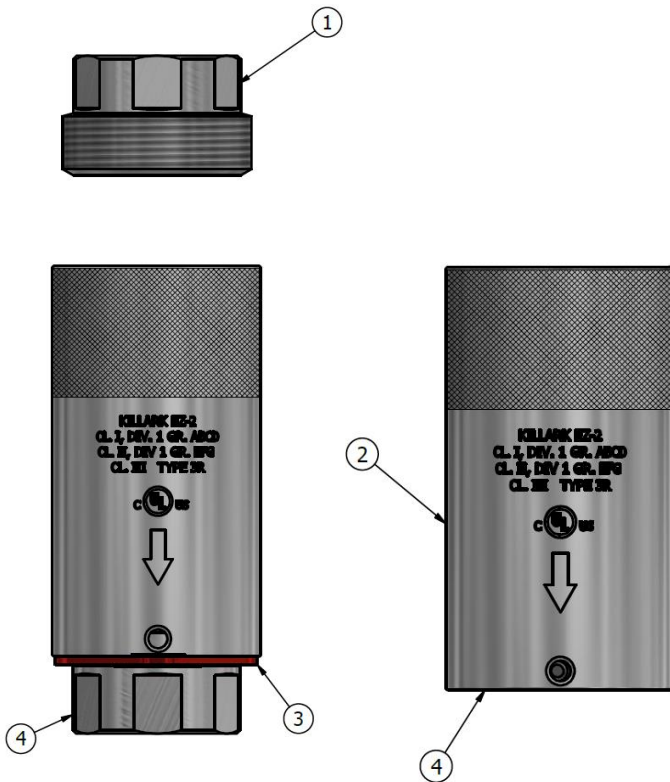

F)

- With a new EZ Seal, unthread the top nut (1) from the coupler (2) and keep for later use.
- Remove the EZ tab (3) and keep for later use.
- Push the potting chamber (4) up inside the coupler (4).

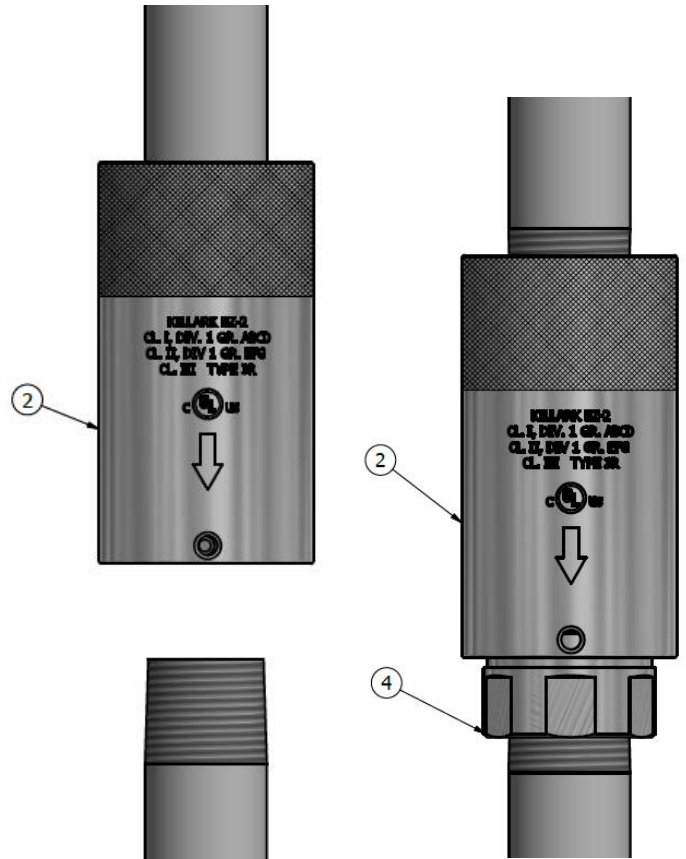

G)

- Position the coupler (2) between the conduit threads.
- Thread the potting chamber (4) onto the bottom conduit pipe and pull the couple (2) up.
- Install potting chamber (4) onto the NPT conduit hand tight plus 1 turn with a wrench.



KILLARK

HUBBELL INCORPORATED (Delaware)
2112 Fenton Logistics Park Blvd
Fenton, Missouri 63026 USA

**INSTALLATION, OPERATION &
MAINTENANCE DATA SHEET**
EZ Seal Retro Fit Installation
For use in Hazardous Locations

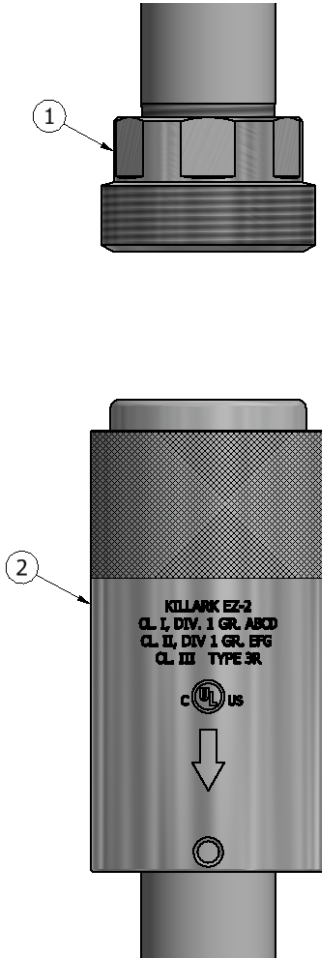

H)

- Slide coupler (2) down.
- Install top nut (1) onto the top NPT conduit hand tight plus 1 turn with a wrench.



I)

- With the coupler (2) open, use preferred wire-pulling method to pull conductors thru the EZ Seal.
- Stagger and use electrical tape on conductors to ease wire pulling thru the pre-installed sealing barrier.

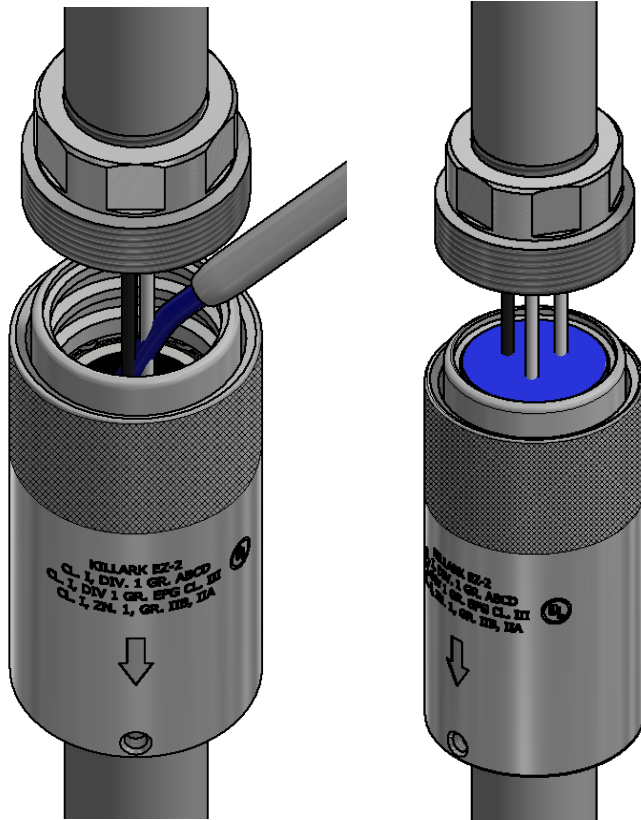

E)

- When wire-pulling is complete, ensure there are no gaps between the conductors and the pre-installed seal. If there are any gaps, use Killark “PF” Packing Fiber to plug any gaps.
- Use Killark’s QQS “CELOX” epoxy or “SC” Sealing Compound to seal the potting chamber (4). See sheets 5 & 6 for sealing material instructions.
- Be sure to separate the conductors to guarantee sealing material fully surrounds them. See Table (1) on sheet 6 for required sealing depth.
- Take care to avoid spilling any sealing material onto the outside surface of the potting chamber (4). Immediately clean any sealing material that touches the outside surface of the potting chamber as any residual sealing material that hardens will make assembly of the coupler (2) to the top nut (1) difficult.

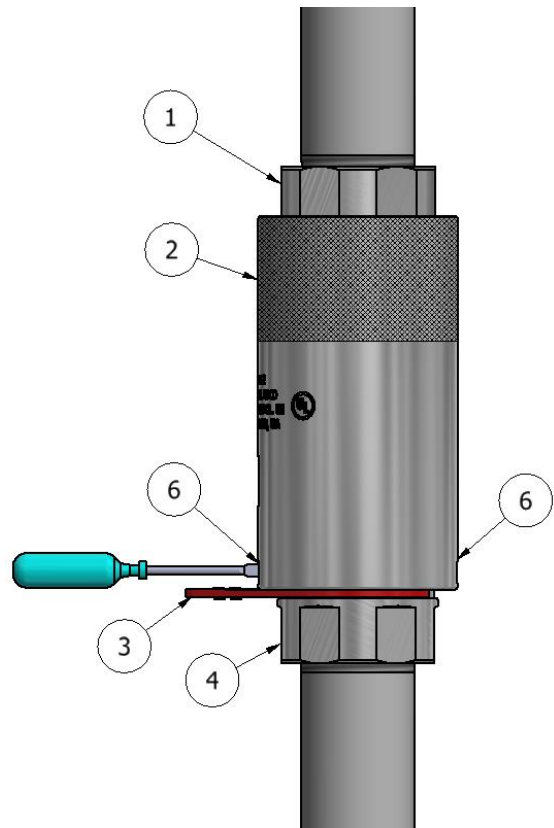

F)

- Once sealing compound has hardened, raise the coupler (2) up to the top nut (1) until fully threaded and tightened hand tight.
- Using a flat head screwdriver, tighten set screw (6) using a minimum of 4 in-lbs.
- Replace the positioning tab (3) to indicate seal has been poured.

NOTE: If set screw is not accessible when the coupler is hand tight to the top, back the coupler off and remove set screw and retighten the coupler. The set screw can be moved to the other position if necessary.

Liquid Resin Preparation

1. When using Killark KQS “CELOX” remove cap by twisting 90° counterclockwise for 50mL cartridge. For larger 250mL cartridge unscrew cap counterclockwise and remove plug (Plug can be saved for re-use of cartridge).
2. Place mixing nozzle onto cartridge and lock into place by twisting 90° for 50mL and screw clockwise for 250mL cartridge. Place 50mL cartridge into the dual dispensing applicator and 250mL cartridge into a high ratio caulking tool.
3. Prime mixing nozzle by depressing handle and pump a small amount of sealing compound through nozzle until a uniform mixture is dispensed (Gray mixture for KQS).
4. See chart below for Cure Time vs Temperature when using KQS.

NOTES:

- The mixing and installation of the compound at an ambient temperature below 4°C (39°F) is not recommended due to extended curing periods.
- The compound may be adversely affected by some solvent vapors. If such vapors are likely to be present in the vicinity of the cable gland in service, suitable precautions may be necessary. (Contact Killark Customer Service).
- If un-used liquid resin cartridge is stored below 0°C, bring cartridge to room temperature for 24 hours before using for installation.

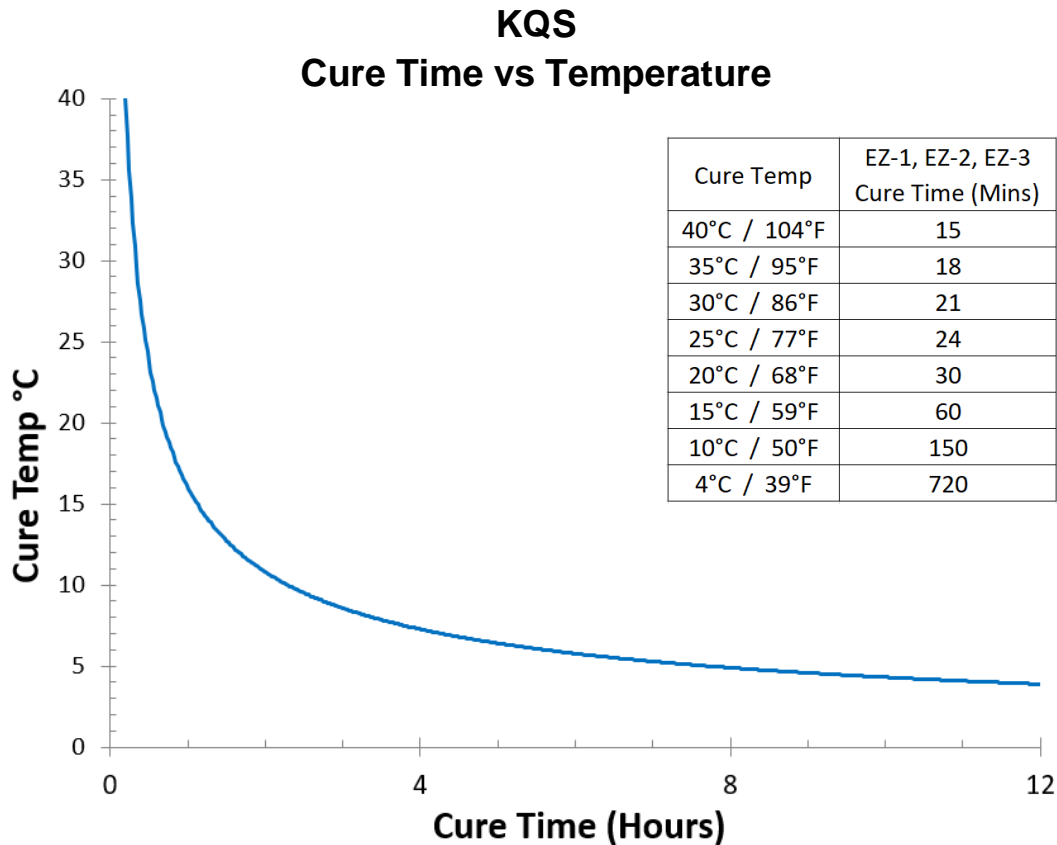

Sealing Compound Preparation

1. When using Killark Type “SC” Sealing Compound, mix the sealing compound with water at a rate of 3.3 parts of compound to 1-part water by volume (4 to 1 by weight).
2. Use a clean mixing vessel for each batch. Sprinkle the sealing compound into water while stirring; continue mixing for at least 3 MINUTES. The proper consistency is just fluid enough to pour SLOWLY, like thick gravy (NOT WATERY) and should have a smooth silky shimmer in appearance when mixed correctly.
3. Do not mix more material than can be poured in 15 minutes. Discard any sealing compound that has become too stiff to use. Never attempt to restore workability by stirring in more water.
4. After the compound is mixed properly, slowly pour it into the sealing fitting. Make sure the wires are separated so the compound will completely surround them. Pour slowly to avoid trapping air bubbles in the compound and fill to the required level shown in Table 1.

CAUTION: FOR GROUPS A, B, C & D

5. Sealing compound to be mixed at a temperature no lower than 40°F/4°C and ONLY poured into fittings that have been brought to a temperature of 40°F/4°C. Seals must NOT be exposed to temperatures below 40°F/4°C for at least 72 hours. Compound poured at 4°C must be allowed 72 hours to cure to full strength before energizing system.
6. Compound poured at 20°C must be allowed 24 hours to cure to full strength before energizing system.

**Table (1):
 Minimum Sealing Depth**

EZ Seal P/N	Seal Depth (in)
EZ-1	0.76
EZ-2	0.83
EZ-3	1.11

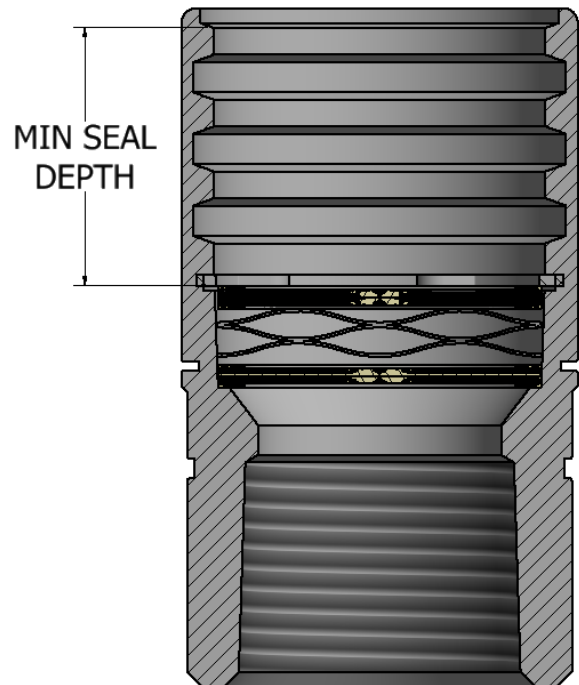

Table (2): EZ Seal Maximum (25%) Wire Fill Chart

The maximum number of wires ^{a,b} that can be sealed in a sealing fitting are as follows:						
Size AWG or kcmil	1/2 inch		3/4 inch		1 inch	
	A	B	A	B	A	B
18	7	11	12	20	12	20
16	6	9	10	16	17	27
14	3	8	6	15	10	24
12	3	6	5	11	8	18
10	1	4	4	7	7	11
8	1	2	2	4	4	6
6	1	1	1	2	2	4
4	1	1	1	1	1	2
3	-	-	1	1	1	2
2	-	-	1	1	1	1
1	-	-	1	1	1	1
0	-	-	-	-	1	1
2/0	-	-	-	-	1	1
3/0	-	-	-	-	1	1
a: Col. A = Types RFH-2, RH, RHH, RHW, THW, TW, XHHW (AWG 14-6), FEPB (AWG 6-2)						
Col. B = FEP, THHN, TFN, PF, PGF, XHHW (AWG 4 - 2000 kcmil), FEPB (AWG 14-8)						
b: Any combination of these wires not exceeding 25 percent of a cross section of the conduit for the fitting they fill may be used.						