



[Catalog Home](#)

Product Datasheet

CHANCE

CTB5M19 -- BRACKET, XFMR, RACK TYPE, AL

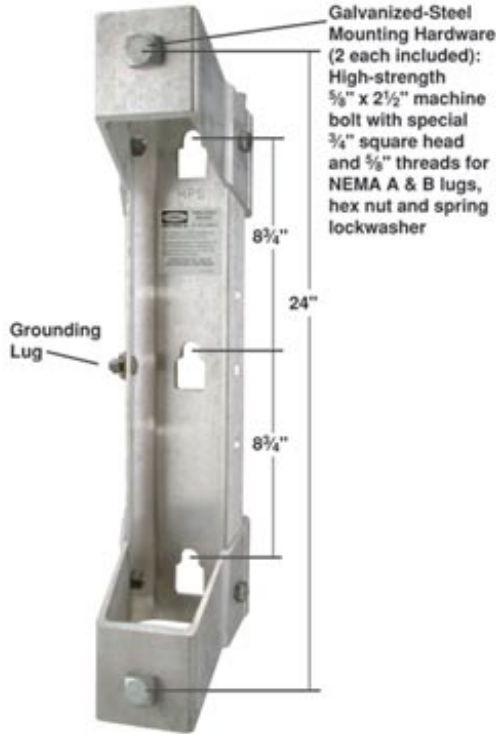

Bracket, Transformer, Wing-Rack Type

Product Specifications

Product Categories	Equipment Mounting Brackets
Product Group	Bracket, Transformer, Aluminum
Product Type	Bolted
Size	Not Applicable for Bolted Type
Diameter	Not Applicable for Bolted Type
Transformer Lug Configuration	NEMA A or B, 12" or 24" Vertical Spacing
Material	6061-T6 Aluminum
Return Type	Non-Standard
UPC Code	096359354901
Standard Package	4
Unit of Measure	EA
Min Order Qty	4
Weight / Ea.	13.41 lbs
Webpage	Click HERE to view webpage
Drawing	Click HERE to view drawing.

Notes

Maximum capacity is 2000 lb. With two thru-bolts and 3000 lb. with three thru-bolts.

Compressed Product Number

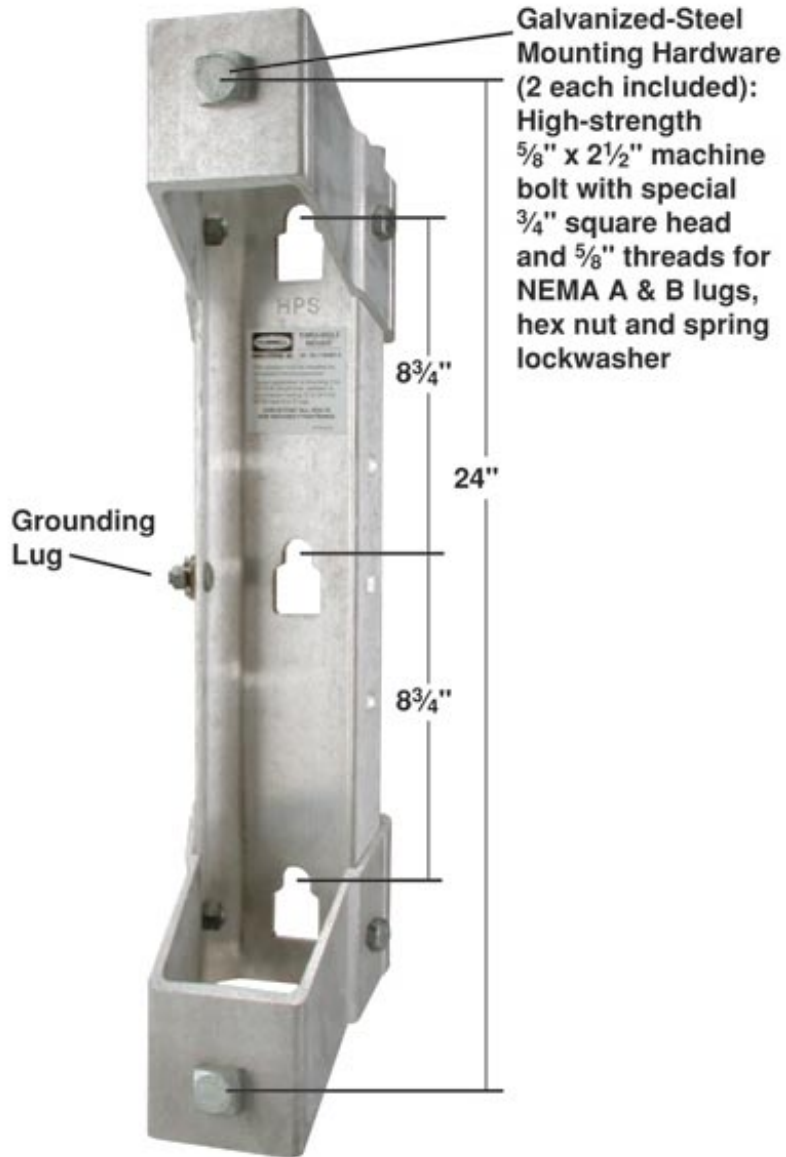

Catalog Home



[Warranty Info](#) | [Trademarks](#) | [Terms of Use](#)

All contents Copyright © 2007 Hubbell Power Systems, Inc. All rights reserved.

NOTE: Because Hubbell has a policy of continuous product improvement, we reserve the right to change design and specifications without notice.