

Instruction Bulletin

80442-291-01B
April 1998
Seneca, SC, USA

ALTIVAR™

Adjustable Speed Drive Controllers in Motor Control Centers Class 8998



NEMA Type 1 and 1A Gasketed Enclosures Only

**1–40 hp 460 V Constant Torque Drives
1–40 hp 460 V Variable Torque Low Noise Drives
1–50 hp 460 V Variable Torque Drives**



SQUARE D

TABLE OF CONTENTS

SECTION 1—INTRODUCTION 1

SECTION 2—SAFETY PRECAUTIONS 2

SECTION 3—RECEIVING, HANDLING, AND STORAGE 3

SECTION 4—INSTALLATION 4

 Unit Identification 4

 Control and Load Wiring 5

 Cable Connection Torque Values 6

 Wire Routing and Interconnection 7

SECTION 5—OPERATION 9

 Factory Settings 9

SECTION 6—MAINTENANCE 11

 Power Fuse Recommendation and Location 12

 Plug-on Unit Removal 14

 Plug-on Unit Installation 18

 Cooling System Maintenance 19

 Duct System Cleaning 19

 Definitions 19

 Horizontal Operator Axial Fan Removal 20

 Horizontal Operator Axial Fan Installation 20

 Vertical Operator Axial Fan Removal 21

 Vertical Operator Axial Fan Installation 22

 Motorized Impeller Removal 23

 Motorized Impeller Installation 24

 Insulation Test 24

 Troubleshooting—Drive Overheating 25

 Troubleshooting—Drive Will Not Run 26

 Spare Parts 27

APPENDIX A—SAMPLE ALTIVAR PARAMETER SHEET 29

APPENDIX B—FIELD WIRING TERMINATION DRAWINGS 30

LIST OF FIGURES

Figure 1: Proper Lifting Points for Units. 3

Figure 2: Not a Recommended Lifting Point for
Units Taller than 24 in [610 mm] 3

Figure 3: Unit Label Locations (Frame Sizes 1–3) 4

Figure 4: Unit Label Locations (Frame Size 4) 4

Figure 5: Field Terminal Block Location 5

Figure 6: Pull-Apart Type Field Terminal Block (FTB). 5

Figure 7: Application-rated COMPACT™ 6 Barrired Bypass 5

Figure 8: Typical Barrired Bypass 6

Figure 9: Fuse Location for Frame Size 1 13

Figure 10: Fuse Location for Frame Size 2 13

Figure 11: Fuse Location for Frame Size 3 13

Figure 12: Fuse Location for Frame Size 4 13

Figure 13: Loosening Captive Quarter-Turn Fasteners. 15

Figure 14: Closeup of Nut Fasteners
(Top View of Control Station Plate) 15

Figure 15: Removing Control Station Plate
And Keypad Holder (Rear of Unit Door). 15

Figure 16: Releasing Lock-in Device. 16

Figure 17: Removing Shoulder Bolts. 16

Figure 18: MCC Unit with Lock-in Device and Shoulder Bolts 16

Figure 19: Twin Handle Cam Mechanism
(Unit Disconnect Switch in Off Position). 17

Figure 20: Operating-Mechanism-to-Structure Interlock
(Unit Disconnect Switch in On Position). 17

Figure 21: Padlocking Partially Withdrawn Unit. 17

Figure 22: Proper Lifting Points for Units Taller than 24 in [610 mm] 18

Figure 23: Not a Recommended Lifting Point for
Units Taller than 24 in [610 mm] 18

Figure 24: Twin Handle Cam Mechanism Removal
(Horizontal Operator Mechanism) 20

Figure 25: Top Duct Cover Removal
(Horizontal Operator Mechanism) 20

Figure 26: Fan Removal (Horizontal Operator Mechanism) 20

Figure 27: Block-Off Plate Removal
(Vertical Operator Mechanism) 21

Figure 28: Top Duct Cover Removal—Front Mounting Screws
(Vertical Operator Mechanism) 21

Figure 29: Top Duct Cover Removal—Rear Mounting Screws
(Vertical Operator Mechanism) 22

Figure 30: Fan Removal (Vertical Operator Mechanism—Top View) 22

Figure 31: Impeller Wiring Removal 23

Figure 32: Impeller Screw Removal 23

Figure 33: Motorized Impeller Removal. 24

Figure 34: Field Wire Termination Diagram for Basic Frame Size 1
ALTIVAR Drive Controller 30

Figure 35: Field Wire Termination Diagram for Frame Size 1
ALTIVAR Drive Controller with Extended Options 32

Figure 36: Field Wire Termination Diagram for Basic
Frame Size 2 ALTIVAR Drive Controller 34

Figure 37: Field Wire Termination Diagram for Frame Size 2
ALTIVAR Drive Controller with Extended Options 36

Figure 38: Field Wire Termination Diagram for Basic Frame Size 3
ALTIVAR Drive Controller38

Figure 39: Field Wire Termination Diagram for Frame Size 3
ALTIVAR Drive Controller with Extended Options40

Figure 40: Field Wire Termination Diagram for Basic Frame Size 4
ALTIVAR Drive Controller42

Figure 41: Field Wire Termination Diagram for Frame Size 4
ALTIVAR Drive Controller with Extended Options44

LIST OF TABLES

Table 1:	Wire Routing and Interconnection	8
Table 2:	Power Fuse Recommendation and Location	12
Table 3:	Disconnect Switch Assemblies (SW)	27
Table 4:	Circuit Breaker Disconnect Assemblies (BKR)	27
Table 5:	CL1 and CL2 Fuses	27
Table 6:	Fan Fuses	28
Table 7:	Bulbs	28
Table 8:	Air Movers	28
Table 9:	Pilot Devices	28
Table 10:	Control Power Transformers (CPT)	28
Table 11:	Field Wire Termination Chart for Basic Frame Size 1 ALTIVAR Drive Controller	30
Table 12:	Field Wire Termination Chart for Frame Size 1 ALTIVAR Drive Controller with Extended Options	31
Table 13:	Field Wire Termination Chart for Basic Frame Size 2 ALTIVAR Drive Controller	33
Table 14:	Field Wire Terminations for Frame Size 2 ALTIVAR Drive Controller with Extended Options	35
Table 15:	Field Wire Termination Chart for Basic Frame Size 3 ALTIVAR Drive Controller	37
Table 16:	Field Wire Terminations for Frame Size 3 ALTIVAR Drive Controller with Extended Options	39
Table 17:	Field Wire Termination Chart for Basic Frame Size 4 ALTIVAR Drive Controller	41
Table 18:	Field Wire Terminations for Frame Size 4 ALTIVAR Drive Controller with Extended Options	43

SECTION 1—INTRODUCTION

This instruction bulletin provides supplementary installation and maintenance information for ALTIVAR adjustable speed drive controllers in Square D Class 8998 motor control centers (MCCs). The information provided in this bulletin should be read in addition to all other documents shipped with the MCC.

Several features of the MCC ALTIVAR drive controller units require the instructions contained in this document in addition to instructions for standard MCC units. The purpose of this document is to provide the user with additional information necessary for installation and maintenance of the MCC drive controller units.

Reference documents shipped with ALTIVAR drive controllers and Class 8998 motor control centers include:

- *Model 6 Motor Control Center Instruction Bulletin* (8998IM9201_) or *Model 5 Motor Control Center Installation and Maintenance Instruction Bulletin* (8998IM9101_)
NOTE: These two bulletins are referred to herein as "MCC instruction bulletin."
- *ALTIVAR 66 Receiving, Installation, and Start-up Instruction Bulletin* (VD0C06S304_) or *ALTIVAR 56 User's Manual* (50006-519-01_)
- *ALTIVAR 66 Level 1 and 2 Configuration Instruction Bulletin* (VD0C06S305_)
- *ALTIVAR 66 I/O Extension Module and Level 3 Configuration Instruction Bulletin* (VD0C06T306_)
NOTE: included in package only if I/O extension module was provided
- Drawings specific to the order

To replace missing documents, contact your local Square D field office.

The Square D motor control center ALTIVAR drive controller unit consists of a pre-engineered motor control center unit with disconnect and an ALTIVAR ac drive controller for adjustable speed control of standard 3-phase asynchronous motors.

Each MCC drive controller unit contains current limiting fuses to achieve the short circuit rating of the unit. Each unit also contains a cooling system for thermal management. Various control and power contactor options may be included with the unit. Drawings shipped with the unit list all included options.

The ALTIVAR drive controller is factory set for use in most common applications. Many settings are programmed according to the power or control options ordered with the MCC drive controller unit and should not be adjusted. To adjust the drive controller for a particular installation, refer to the drawings included with the order and to the *ALTIVAR 66 Level 1 and 2 Configuration Instruction Bulletin* or *ALTIVAR 56 User's Manual* (listed above).

SECTION 2—SAFETY PRECAUTIONS

⚠ DANGER

HAZARD OF ELECTRIC SHOCK, BURN, OR EXPLOSION

- Turn OFF all power supplying this equipment before working on or inside the motor control center. Equipment must be de-energized during all installation and maintenance operations.
- Before performing visual inspections, tests, or maintenance on the equipment, disconnect all sources of electric power. Assume that all circuits are live until they have been completely de-energized, tested, grounded, and tagged. Pay particular attention to the design of the power system. Consider all sources of power, including the possibility of backfeeding.
- Use a properly rated voltage sensing device to confirm that all power is off.
- After disconnecting power, wait one minute before servicing a drive controller in order to allow the dc bus capacitors to discharge. After one minute, measure the dc bus capacitor voltage between the “+” and “-” terminals to verify that dc voltage is less than 45 Vdc. The dc bus LED is not an accurate indication of the absence of dc bus voltage. For additional information, refer to page 51 of the *ALTIVAR 66 Receiving, Installation, and Startup Manual* (VD0C06S304_) or *ALTIVAR 56 User's Manual* (50006-519-01_).
- Do not short across dc bus capacitors or touch unshielded components or terminal strip screw connections with voltage present.
- Many parts in the drive controller—including printed wiring boards—operate at line voltage. Do not touch. Use only electrically insulated tools.
- Use out-of-service tags and padlocks when working on equipment. Leave the tags in place if you leave the area or until the work is completed and the equipment is ready for service.
- Use only test equipment rated for the service intended.
- All personnel involved in handling, installation, testing, operation, and maintenance should be thoroughly familiar with the information in this instruction bulletin and the reference documents listed on page 1 of this bulletin before working on this equipment. They must have a thorough understanding of electrical equipment in general, the specific operation of this particular equipment, and the types and severity of potential injury. They must also be trained in the proper use of appropriate protective equipment.
- Follow all applicable OSHA 29 CFR Part 1910, NFPA 70E Part II, and any other applicable local standards and regulations before working on this equipment.

Failure to observe these instructions will result in death or serious injury.

SECTION 3—RECEIVING, HANDLING, AND STORAGE

Observe the following precautions for MCC drive controller units shipped to the site as a unit:

- Lifting units larger than 24 in [610 mm] requires two or more persons using special handling precautions and lifting devices.
- If lifting devices are used, refer to Figure 1 for proper lifting points. (Figure 2 illustrates a lifting point that is NOT recommended for larger units or when using lifting devices.)

Refer to the appropriate MCC instruction bulletin (Model 5 or Model 6) for information about receiving, handling, and storage of MCC units and enclosures.

Before installing MCC control units, locate and tighten any connections loosened during shipment and handling. Refer to the procedures in the Maintenance section of the appropriate MCC instruction bulletin (Model 5 or Model 6).

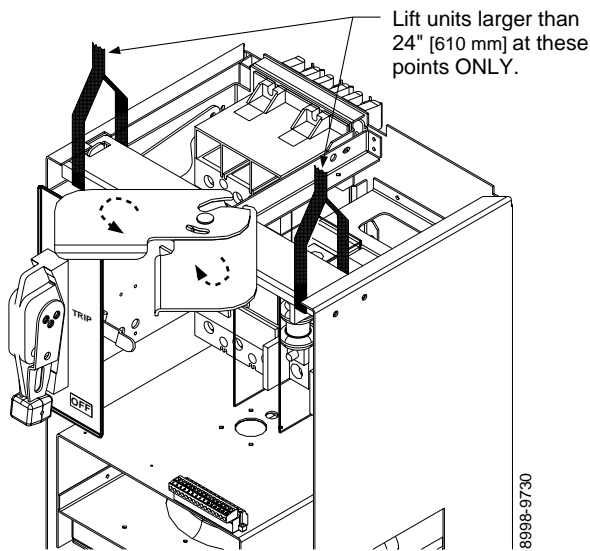

Figure 1: Proper Lifting Points for Units

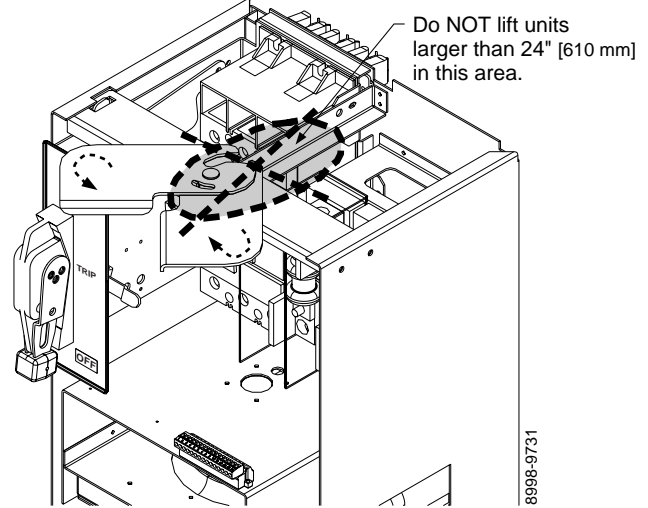

Figure 2: NOT A Recommended Lifting Point for Units Taller Than 24 in [610 mm]

SECTION 4—INSTALLATION

Unit Identification

This section contains details specific to ALTIVAR drive controller installation. For details specific to motor control center installation, refer to the Installation section in the appropriate MCC instruction bulletin (Model 5 or Model 6).

The unit identification label and unit rating label are located on the inside wall of the MCC drive controller unit (see Figure 3 and Figure 4). In addition, each drive controller has a bar code label in the lower right corner of smaller horsepower drive controllers or on the side of larger horsepower drive controllers. The bar code contains, among other information, the open type drive controller catalog number (for example, ATV*6***N4U).

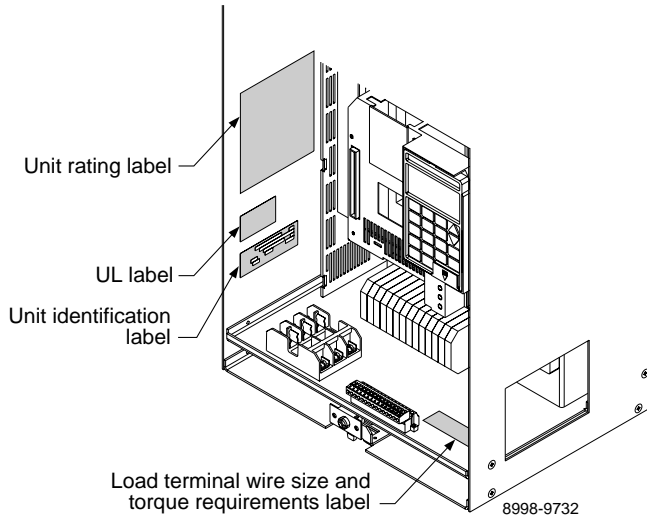

Figure 3: Unit Label Locations (Frame Sizes 1–3)

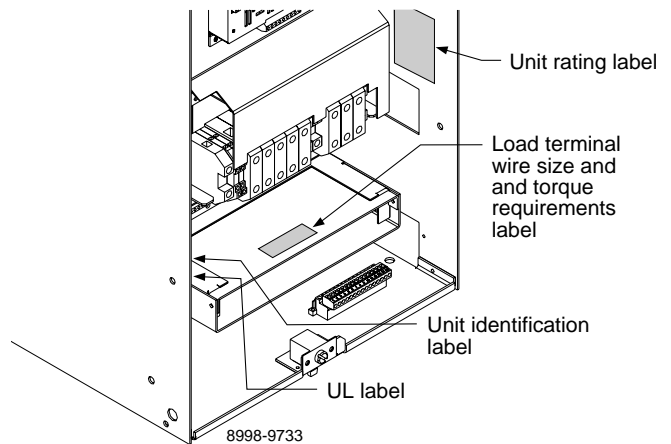

Figure 4: Unit Label Locations (Frame Size 4)

Control and Load Wiring

Pull-apart type terminal blocks for field-installed control wiring are mounted on the floor of the unit (Figure 5). Terminate field control wiring on the removable (top) portion of the terminal block. To separate or remove the top portion of the terminal block from the base, grasp the top half and pull up (Figure 6). The terminal block is designated “FTB” on the unit’s wiring diagrams and in the figures in this bulletin.

Each terminal is rated for one #16-12 AWG wire or two #16 AWG wires. Torque terminal screws to 5 in-lbs (0.6 N•m).

Depending on power and control options ordered, several analog or digital inputs and outputs are available at the control terminal blocks located on the ALTIVAR drive controller. Refer to the wiring diagram supplied with the MCC drive controller unit for I/O availability. Refer to the ALTIVAR drive controller configuration instruction bulletins (listed on page 1) for I/O specifications and adjustments.

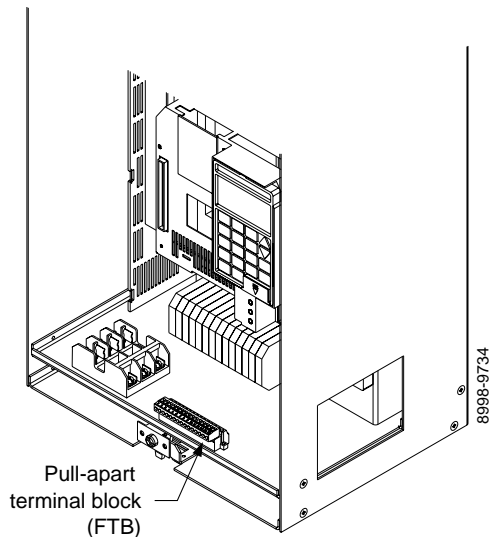

Figure 5: Field Terminal Block Location

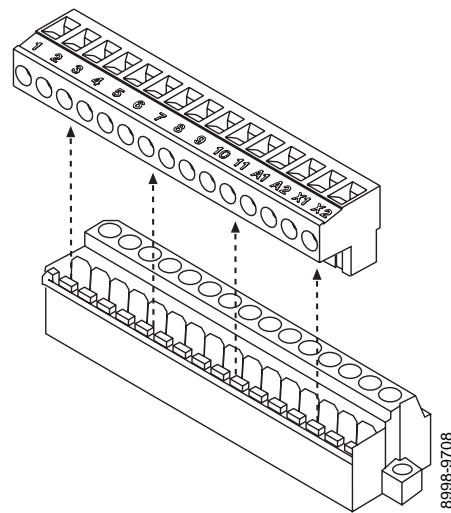

Figure 6: Pull-apart Type Field Terminal Block (FTB)

If a barriered bypass is supplied, additional pull-apart type terminal blocks are provided in the bypass starter (see Figure 7 and Figure 8 for location). Some control schemes require connection to the terminal blocks in the bypass starter for field control wiring. In this instance the wiring diagram designates the terminal block as “FTB” in the bypass starter location.

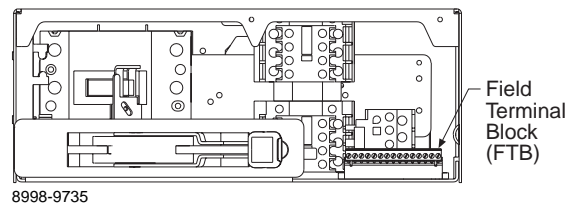

Figure 7: Application-Rated COMPACT™ 6 Barriered Bypass

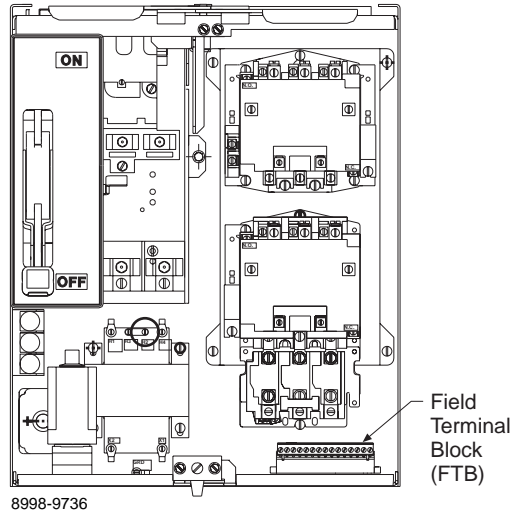

Figure 8: Typical Barried Bypass

Cable Connection Torque Values

Load terminal wire size and torque requirements are listed on the torque label located inside the MCC drive controller unit adjacent to the wiring port on the right side of the unit (Figure 3 and Figure 4 on page 4 for label locations).

Wire Routing and Interconnection

The controller Field Wiring Termination information in “Appendix B—Field Wiring Termination Drawings” on page 30, provides the required torque and maximum allowable wire size for each field wiring terminal. This information also provides requirements for the Wire Class, Noise Class, and Voltage Class of the field connected conductors. These classes are described below.

Wire Class

Compatibility of the field wiring terminal with the conductor material and insulation system is described by Wire Class. When used with the required conductor current rating and controller-rated ambient temperature, the Wire Class forms the basis for the selection of a conductor size, which limits the temperature on the conductor insulation at the field wiring terminal to an acceptable range. Conductors with operating temperatures exceeding those specified by the Wire Class may be used, but the conductor size must be selected based on Wire Class limits.

Noise Class

Electromagnetic properties of the voltages and currents present are categorized by Noise Class. Wiring is classified into the following six noise classes for selection of wiring methods and physical segregation purposes.

Quiet Wiring 1 (QW1)

High susceptibility analog and digital control signals.

Signals in this classification include digital communication and network circuits, controller analog input/output (I/O), and analog process signals.

Quiet Wiring 2 (QW2)

Medium susceptibility, analog, and digital control signals.

Signals in this classification include 24 V dc and ac control circuits.

Standard Wiring 1 (SW1)

Low susceptibility control or power circuits rated less than 600 Vac (250 Vdc) and less than 15 amps. NOTE: Voltage and current spectra are generally contained within 0.05–9 kHz.

Signals in this classification include 120 Vac control circuits.

Standard Wiring 2 (SW2)

Power circuits rated greater than 15 amps. NOTE: Voltage and current spectra are generally contained within 0.05–9 kHz.

Signals falling under this classification include line power to controllers.

Standard Wiring 3 (SW3)

Reserved.

Pulse Wiring 1 (PW1)

Control or power circuits whose voltage or current spectra significantly exceed 9 kHz.

Signals in this classification include motor and dynamic braking circuits fed from pulse width modulated (PWM) power converters.

Voltage Class

The voltages present at the field wiring terminals are categorized by Voltage Class. Voltage is classified into recognized conductor insulation categories (30 V, 150 V, 300 V, and 600 V) for the selection of conductor insulation voltage rating and physical segregation purposes.

Based on the noise class and voltage class of the conductors, apply the wiring methods listed in Table 1 on page 8 to the drive system.

Table 1: Wire Routing and Interconnection

Wiring Methods and Considerations	Noise Class of Conductors				
	QW1	QW2	SW1	SW2	PW1
Conductor Grouping in Wireways/Conduits					
1. All conductors of a 1- or 3-phase power circuit must be bundled to minimize stray magnetic fields.			X	X	X
2. All conductors of a dc power circuit must be bundled to minimize stray magnetic fields.			X	X	X
3. When paralleled conductors must be run in separate wireways or conduit, minimize stray magnetic fields by bundling the conductors into groups.				X	X
4. Maintain conductor runs as short as practical.	X	X	X	X	X
Separation of Circuits					
1. DO NOT run different Noise Class conductors in the same conduit.	X	X	X	X	X
2. DO NOT run different Voltage Class conductors in the same conduit unless all conductors are insulated for maximum Voltage Class present.	X	X	X	X	X
3. Outside the enclosure, all PW conductor groups must be individually segregated using metallic conduit.					X
4. Segregate all conductors by Noise Class. Use the following circuit separation when conductors can run parallel for more than 12 inches:					
• Metallic conduit: 3 inches between QW to SW/PW	X	X	X	X	X
• Metallic tray: 3 inches between SW and PW			X	X	X
• Metallic tray: 6 inches between QW and SW/PW	X	X	X	X	X
• Against continuous metal surface: 3 inches between SW and PW			X	X	X
• Against continuous metal surface: 6 inches between QW and SW/PW	X	X	X	X	X
• Metallic conduit housing of QW: 12 inches to non-metallic conduit SW/PW	X	X	X	X	X
• Non-metallic conduit: 3 inches between SW and PW			X	X	X
• Non-metallic conduit: 24 inches between QW to SW/PW	X	X	X	X	X
5. If QW and SW wiring must cross SW2 or PW1 wiring, the bundles must cross at right angles.	X	X	X	X	X
Common Mode Noise Issues					
1. Provide adjacent signal returns using twisted pair cable.	X	X			
2. Galvanically isolate signal and associated signal return path when possible.	X	X			
Shielding					
1. Use metallic conduit for all power and control circuits external to the controller enclosure.	X	X	X	X	X
2. Shields should be continuous and equipped with a drain wire.	X	X	X		
3. DO NOT group different Noise Class conductors within the same shield.	X	X	X	X	X
4. Minimize the non-shielded portion of conductor at the ends of shielded cable.	X	X	X	X	X
5. When shielding ac or dc power conductors, group conductors to minimize magnetic field in shield.			X	X	X
Grounding					
1. Ground shields at one end only (controller end).	X	X	X	X	X
2. Use separate ground wire for each shield ground.	X	X	X	X	X
3. Provide a ground wire with all conductor groups whether in tray or conduit.			X	X	X
4. When multiple grounds must be made to a shielded power cable, the shield must have the same short circuit withstand capability as the ground conductor in the power cable.			X	X	X
5. Terminate all power grounds and shield grounds to the controller grounding point or bar.			X	X	X
6. Terminate all signal shield grounds to the terminals provided.	X	X			
7. Always supply a separate equipment grounding conductor with the controller power feed. DO NOT depend upon metallic conduit for ground connection.			X	X	X

SECTION 5—OPERATION

▲ WARNING

UNINTENDED EQUIPMENT ACTION

- Read and understand the *ALTIVAR 66 Level 1 and 2 Configuration Instruction Bulletin* (VD0C06S305_) or *ALTIVAR 56 User's Manual* (50006-519-01_) before using the keypad display.
- Lock keypad after making parameter adjustments.
- Do not reset drive parameters to configurations other than those specified on the parameter sheets supplied by Square D with the drive controller. Some factory-set drive parameters are critical for MCC drive controller unit control and power configurations.
- Do not alter programming of factory-installed control devices or power contactors.

Failure to observe these instructions can result in death or serious injury.

*NOTE: Before operating the drive controller, perform the procedures listed in **Factory Settings** (below).*

For complete information on MCC ALTIVAR drive controller unit operation, refer to *ALTIVAR 66 Level 1 and 2 Configuration Instruction Bulletin* (VD0C06S305_) or *ALTIVAR 56 User's Manual* (50006-519-01_) and any drawings supplied with the unit.

If an I/O extension module was provided, refer to *ALTIVAR 66 I/O Extension Module and Level 3 Configuration Instruction Bulletin* (VD0C06T306) or *ALTIVAR 56 User's Manual* (50006-519-01_) for operation information.

Factory Settings

The ALTIVAR drive controller is software driven. The drive controller unit has been pre-programmed to match the power and control options purchased with the MCC drive controller unit. *NOTE: Do not change the factory-set parameters as indicated on the parameter sheet(s) supplied with the MCC drive controller unit. Several settings are critical to unit control and power configurations.* For information on these settings, refer to the ALTIVAR Parameter Sheets included with your shipment in the packet labeled "Installation/Maintenance Information." (A sample parameter sheet is shown in Appendix A.)

NOTE: For factory settings, refer only to the ALTIVAR parameter sheet(s) shipped with your package. These parameters supersede any parameter information shown in other ALTIVAR drive controller documentation.

The following key parameters should be checked and adjusted before motor operation:

1. Nominal Current
2. Motor Overload

The drive controller is equipped with a number of control algorithms and features for flexibility in application. Self-tuning is incorporated into several of the control algorithms to allow optimal control of the motor.

If the drive controller has been configured as Normal Torque or High Torque control type, follow these precautions:

- The adjustment range of the Nominal Current parameter is 45% to 105% of the drive controller rated output current. This allows the use of motors of equal horsepower size or one horsepower size less than the drive controller horsepower rating. To adjust the Nominal Current parameter, refer to the *ALTIVAR 66 Level 1 and 2 Configuration Instruction Bulletin* (VD0C06S305_) or

ALTIVAR 56 User's Manual (50006-519-01_).

- Before powering up for the first time, compare the motor-nameplate current rating with the output current in:

ALTIVAR 66:

Table 1, Table 2, or Table 3 (depending on the drive controller Torque Type setting) in ALTIVAR 66 Receiving, Installation, and Start-up Instruction Bulletin (VD0C06S304_)

—or—

ALTIVAR 56:

Table 1 or 2 (depending on the drive controller torque type setting) in the ALTIVAR 56 User's Manual (50006-519-01_).

- If the motor rating is not within 45% to 105% of the value in the table, a different drive controller must be used.

▲ WARNING

MOTOR OVERHEATING

Do not use motors with a full load current rating that is not within the adjustment range of the drive controller Nominal Current parameter.

Failure to observe this instruction can result in death or serious injury.

- Each time an ALTIVAR 66 drive controller is powered up, direct current equal to the motor rated current is injected into the motor. This action allows the drive controller to determine the resistance of the motor and set the motor parameters.
- For optimal torque performance, the drive controller and motor should be operated under no load at 50/60 Hz during initial commissioning or any time the motor is changed. This action allows the drive controller to measure key motor parameters.
- The Nominal Current parameter must be set on the drive controller keypad display to match the motor full load current rating. If the Nominal Current parameter cannot be adjusted to the motor full load current, Normal and High Torque control types cannot be used for the application.
- For applications using multiple motors, contact the factory.

SECTION 6—MAINTENANCE

⚠ DANGER

HAZARD OF ELECTRIC SHOCK, BURN, OR EXPLOSION

- This equipment must be installed and serviced only by qualified electrical personnel.
- Turn off all power supplying this equipment before working on or inside.
- Always use a properly rated voltage sensing device to confirm that power is off.
- Replace all devices, doors, and covers before turning on the power to this equipment.
- Before installing or removing power fuses, ensure that the unit disconnect switch is in the OFF position .
- De-energize control units before performing maintenance on them.
- After disconnecting power, wait one minute to allow the dc bus capacitors to discharge. After one minute, measure dc bus capacitor voltage between the “+” and “-” terminals to verify that dc voltage is less than 45 Vdc. The dc bus LED is not an accurate indication of the absence of dc bus voltage. For additional information, refer to page 51 of the *ALTIVAR 66 Receiving, Installation, and Startup Manual* (VD0C06S304_) or *ALTIVAR 56 User's Manual* (50006-519-01B_).
- Do not short across dc bus capacitors or touch unshielded components or terminal strip screw connections with voltage present.

Failure to observe these instructions will result in death or serious injury.

Perform maintenance on the MCC drive controller unit a minimum of once per year, or more frequently if indicated by service conditions and your established maintenance policy. Details specific to maintenance of MCC ALTIVAR drive controller units are outlined herein.

Details specific to maintenance of motor control centers are outlined in the Model 5 and Model 6 MCC instruction bulletins. Before removing a drive from the motor control center for maintenance, refer to the procedures listed under Unit Removal in the Maintenance section of the appropriate MCC instruction bulletin (Model 5 or Model 6).

NOTE: All maintenance must be performed by qualified personnel.

Power Fuse Recommendation and Location

Power fuse clips in MCC ALTIVAR drive controller units accommodate either 600 V Class CC fuses or 600 V Class T fuses, depending on the unit rating. See Table 2 for the appropriate fuse type and mounting location.

Every MCC ALTIVAR drive controller unit is shipped with power fuses factory installed.

Table 2: Power Fuse Recommendation and Location

Constant Torque or Variable Torque (low noise) HP at 460 V	Variable Torque HP at 460 V	Unit Frame Size	ALTIVAR Drive Catalog Number (Square D)	Replacement Fuse Catalog Number (Bussman)	UL Fuse Class	Fuse Ampere Rating	Fuse Location	Square D Part Number
1	1	1	ATV**U41N4U	KTK-R-5	CC	5	Figure 9	25430-10500
2	2	1	ATV**U41N4U	KTK-R-10	CC	10	Figure 9	25430-11000
3	3	1	ATV**U41N4U	KTK-R-15	CC	15	Figure 9	25430-11500
—	5	1	ATV**U54N4U	KTK-R-25	CC	25	Figure 9	25430-12500
5	7.5	1	ATV**U72N4U	KTK-R-25	CC	25	Figure 9	25430-12500
7.5	—	2	ATV**U90N4U	JJS-35	T	35	Figure 10	25417-20350
—	10	2	ATV**U90N4U	JJS-45	T	45	Figure 10	25417-20450
10	15	2	ATV**D12N4U	JJS-45	T	45	Figure 10	25417-20450
15	—	3	ATV**D16N4U	JJS-60	T	60	Figure 11	25499-00653
—	20	3	ATV**D16N4U	JJS-100	T	100	Figure 11	25499-00655
20	25	3	ATV**D23N4U	JJS-100	T	100	Figure 11	25499-00655
25	—	4	ATV**D33N4U	JJS-100	T	100	Figure 12	25499-00655
30	30	4	ATV**D33N4U	JJS-100	T	100	Figure 12	25499-00655
—	40	4	ATV**D33N4U	JJS-125	T	125	Figure 12	25417-21250
40	50	4	ATV**D46N4U	JJS-125	T	125	Figure 12	25417-21250

** ALTIVAR 56 or 66

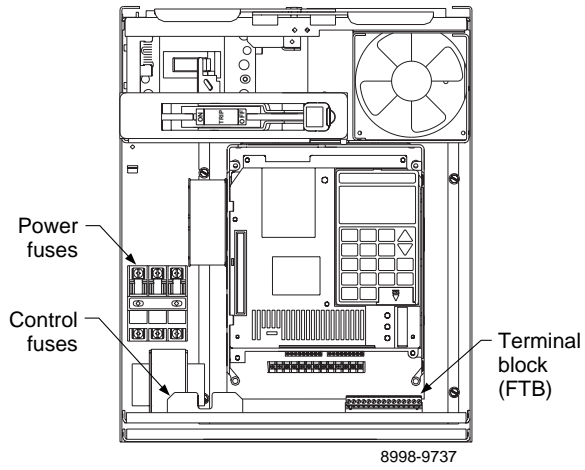

Figure 9: Fuse Location for Frame Size 1

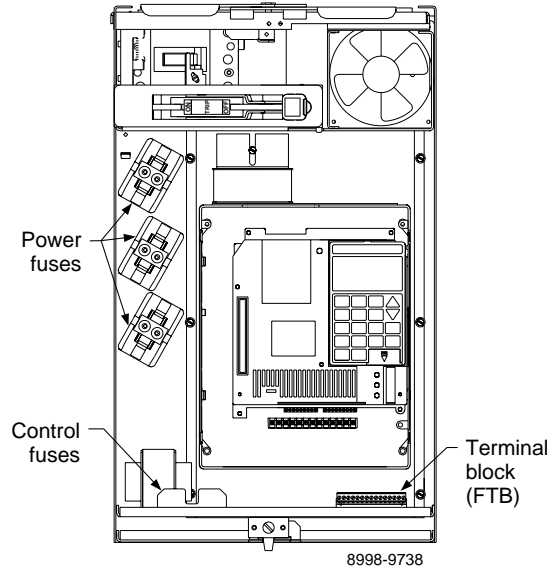

Figure 10: Fuse Location for Frame Size 2

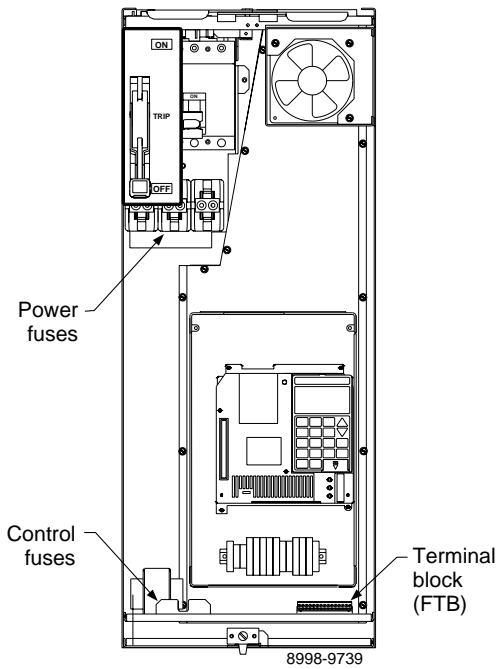

Figure 11: Fuse Location for Frame Size 3

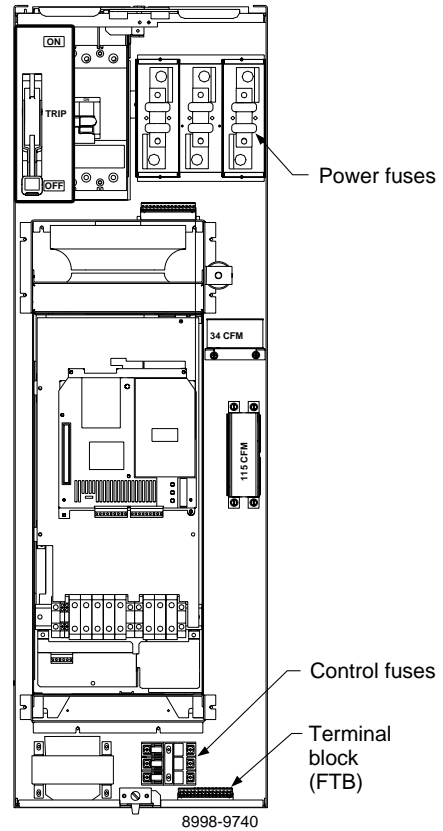

Figure 12: Fuse Location for Frame Size 4

Plug-on Unit Removal

⚠ DANGER

HAZARD OF ELECTRIC SHOCK, BURN, OR EXPLOSION

- Turn OFF all power supplying this equipment before working on or inside equipment.
- Use a properly rated voltage sensing device to confirm all power is OFF. Control units must be de-energized before maintenance is performed.
- The unit disconnect switch must be locked in the OFF position before installation or removal of power fuses.

Failure to observe these instructions will result in death or serious injury.

To remove the plug-on unit:

1. Turn OFF all power supplying this equipment before working on or inside equipment. Move the unit operating mechanism to the OFF position.
2. After disconnecting power, wait one minute to allow the dc bus capacitors to discharge.
3. Loosen the captive quarter-turn fasteners on the unit door (Figure 13 on page 15); open the door. Using a properly rated voltage sensing device set to the 1000 Vdc scale, measure the dc bus capacitor voltage between the “+” and “-” terminals to confirm that the dc voltage is less than 45 Vdc. The dc bus LED is not an accurate indication of the absence of dc bus voltage. **Do not short across the capacitor terminal with voltage present!** If the bus capacitors are not fully discharged, **do not operate the drive controller**; contact your local Square D representative. Check for other live circuits using a properly rated voltage sensing device. De-energize all voltage sources. For additional information, refer to Procedure 1: Bus Voltage Measurement, in the *ALTIVAR 66 Receiving, Installation, and Startup Manual* (VD0C06S304_) or *ALTIVAR 56 User's Manual* (50006-519-01_).
4. As necessary, disconnect the wiring from the drive controller load terminals (T1, T2, and T3) and the drive control terminals (J1, J12, and J13). Tag the terminations for reinstallation.
5. Remove the top portion of the pull-apart control field terminal blocks (FTB) to which the field wiring is connected (Figure 6 on page 5).
6. Insulate the power cable ends that were connected to the terminals (T1, T2, and T3). Push the power leads and the top portion of the pull-apart control terminal blocks through the wiring port and into the vertical wire trough.

7. Remove the control station plate(s) from the rear of the unit door by loosening the four nut fasteners from the rear of each plate (see Figure 14 and Figure 15). Retain all hardware for remounting.

NOTE: On units with two control station plates, a label is provided on each plate indicating the position the plate must occupy (upper or lower). Each control station plate must be re-installed in the position indicated by its label.

8. Remove the keypad holder from the rear of the unit door by loosening the five nut fasteners from the rear of the keypad holder (see Figure 14 and Figure 15). Retain all hardware for remounting.

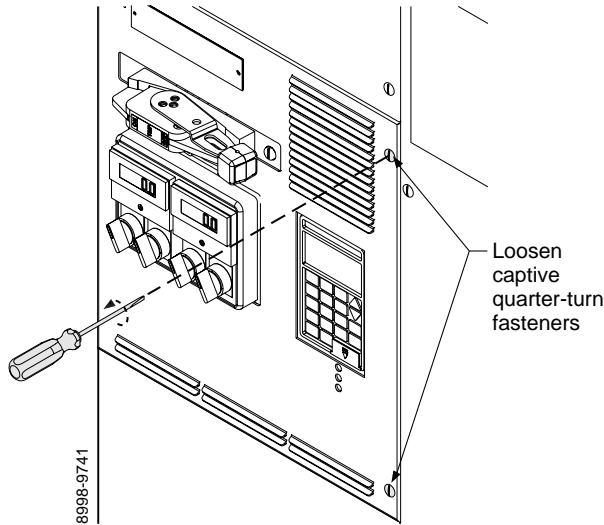

Figure 13: Loosening Captive Quarter-Turn Fasteners (Front of Unit Door)

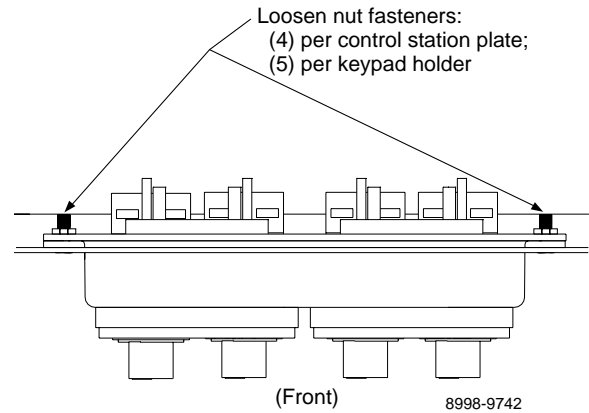

Figure 14: Closeup of Nut Fasteners (Top View of Control Station Plate)

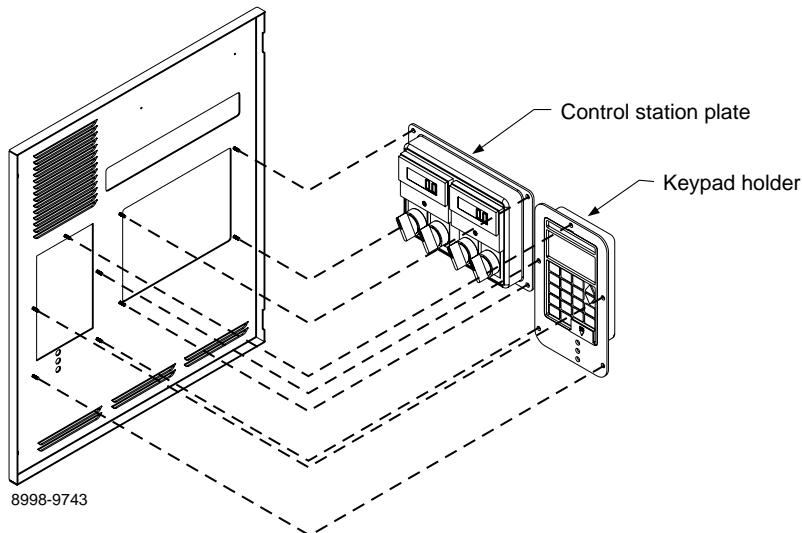

Figure 15: Removing Control Station Plate and Keypad Holder (Rear of Unit Door)

Plug-on Unit Removal (Cont.)

9. If the unit has a lock-in device (at the bottom of the unit), release the device by turning its screw counter-clockwise until the locking pawl is parallel to the bottom of the unit (Figure 16).

If the unit has shoulder bolts (one on each side of the unit), remove the two bolts (Figure 17). Retain the bolts for remounting.

If the unit has both a lock-in device and shoulder bolts (Figure 18), release the lock-in device and remove the bolts. Retain all hardware for remounting.

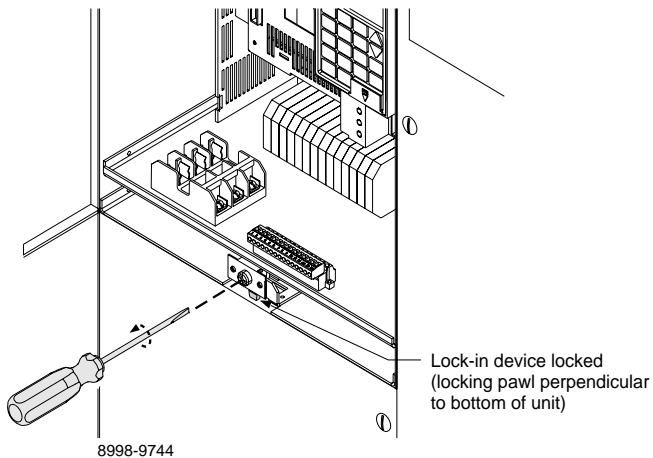

Figure 16: Releasing Lock-In Device

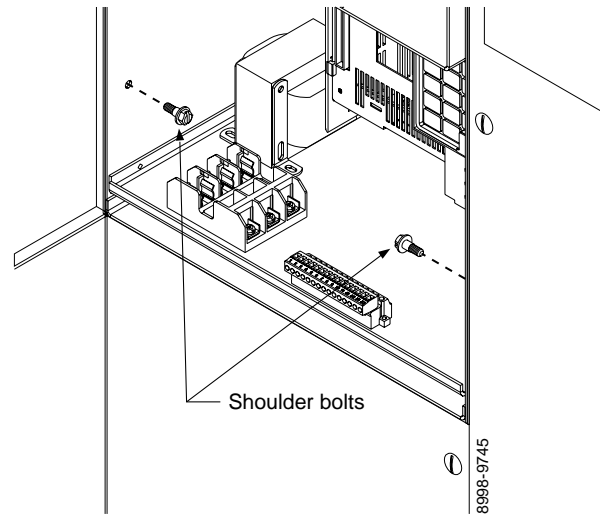

Figure 17: Removing Shoulder Bolts

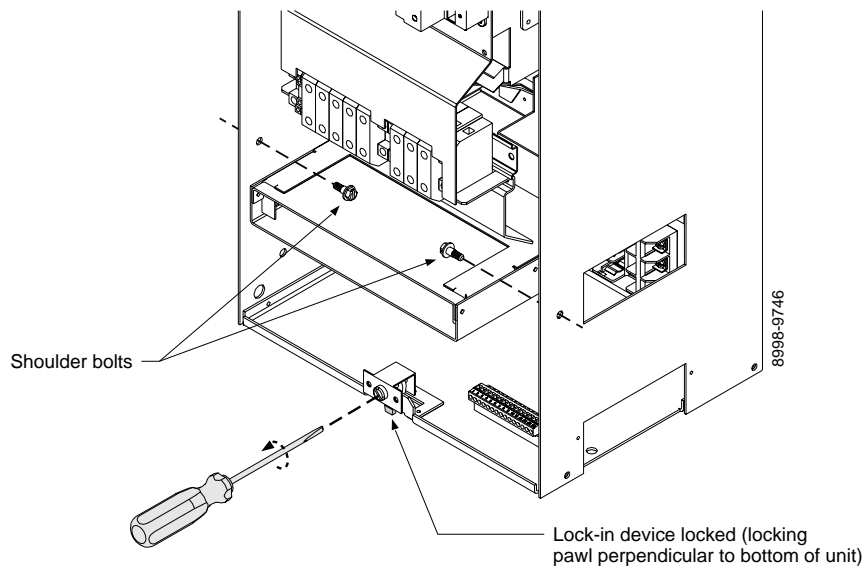
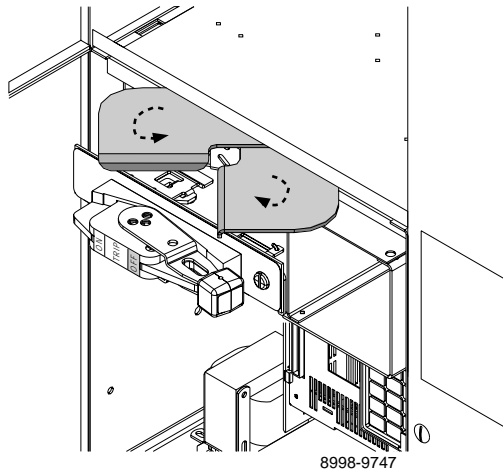

Figure 18: MCC Unit with Lock-In Device and Shoulder Bolts

10. Rack the unit partially out of the MCC structure by pulling forward on the twin handle cam mechanism at the top front of the unit (Figure 19). Continue pulling forward until the handles are fully extended.

NOTE: The unit disconnect device must be in the OFF position. When the disconnect device is in the ON position, the operating-mechanism-to-structure interlock prevents the MCC drive controller unit from being withdrawn (or inserted) (Figure 20).

11. If you choose to leave the partially withdrawn unit in the structure, a padlock can be used to prevent non-authorized personnel from re-loading (Figure 21).



**Figure 19: Twin Handle Cam Mechanism
(Unit Disconnect Switch in Off Position)**

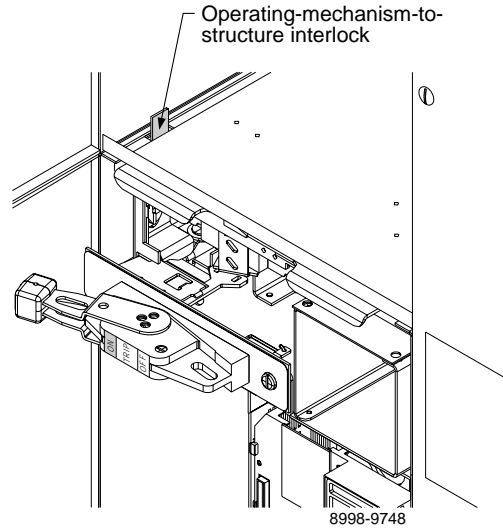

**Figure 20: Operating-Mechanism-To-Structure Interlock
(Unit Disconnect Switch in On Position)**

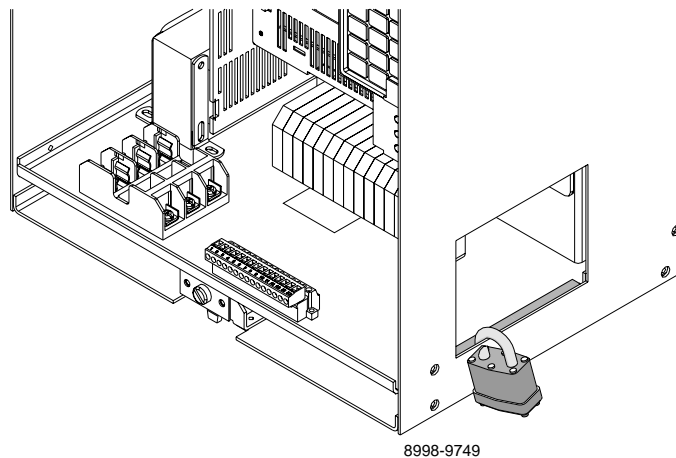

Figure 21: Padlocking Partially Withdrawn Unit

Plug-on Unit Removal (Cont.)

12. Remove the unit from the structure for servicing. To prevent damage to the stab assembly, place the unit flat on its bottom plate.

NOTE: Lifting units taller than 24 in [610 mm] requires two or more persons using special handling precautions. If lifting devices are used on an MCC drive controller unit, refer to Figure 22, which illustrates proper lifting points. (Figure 23 illustrates a lifting point that is NOT recommended when lifting larger units.)

13. If necessary, the unit door can be removed from the structure. Refer to the procedures in the **Control Unit Removal** section of the appropriate MCC instruction bulletin (Model 5 or Model 6).

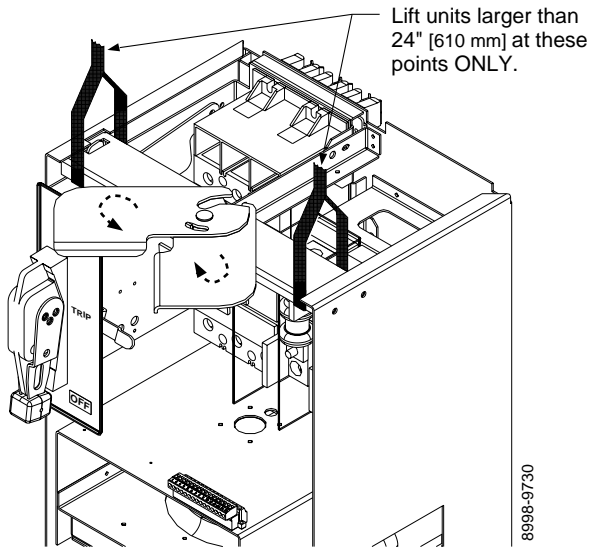

Figure 22: Proper Lifting Points for Units Taller than 24 in [610 mm]

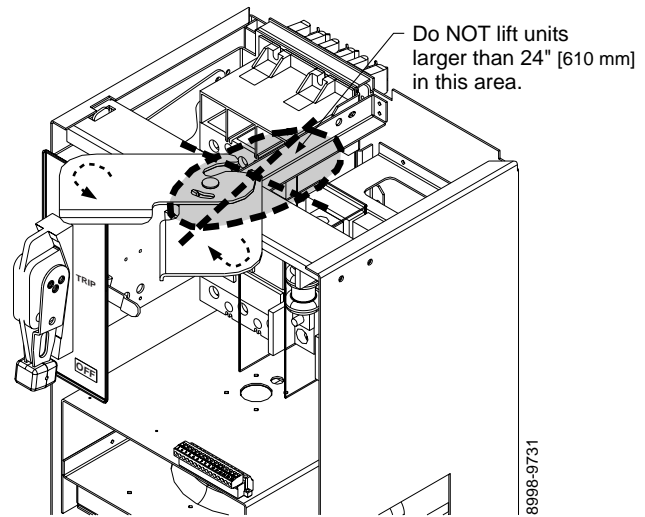

Figure 23: NOT a Recommended Lifting Point for Units Taller than 24 in [610 mm]

For details about servicing components within the MCC drive controller unit, refer to the Maintenance section of the appropriate MCC instruction bulletin (Model 5 or Model 6).

NOTE: If it is determined that the stab assembly, circuit breaker, or fusible switch must be replaced, contact your Square D or Schneider Canada representative to obtain replacement parts.

For details on preventive maintenance for the ALTIVAR drive controller, refer to chapter 4 of *ALTIVAR 66 Receiving, Installation, and Start-up Instruction Bulletin* (VD0C06S304_) or *ALTIVAR 56 User's Manual* (50006-519-01_).

Plug-on Unit Installation

When maintenance is complete, reinstall all units. For MCC drive controller unit installation, follow these steps:

1. Reinstall the door if it was removed.
2. Temporarily secure the keypad, control station plate, and associated wiring inside the unit.
3. Lift the unit and rest on bottom shelf of space the unit will be installed in. Note Figure 22 and Figure 23 when lifting.
4. Align top shelf guides and unit guides. Slide the unit into the structure. Keep sides even when sliding the unit into the structure to prevent binding.

5. When unit is partially inside structure, pull the twin-handle cam mechanism forward to open the slot between them (see Figure 19 on page 17).
6. Slide the unit into the structure until the twin-handle cam mechanism makes contact with the ratcheting pin in the shelf above the unit. Push both handles of the twin-handle cam mechanism until they are flush with the structure.
7. Reinstall the keypad and control station plate onto the doors with the hardware saved during removal.
8. Route all wiring to the keypad and control station plate(s) into the clip fasteners located on the inside of the door. Follow the wire routing instructions that are also located on the inside of the door.
9. Connect the keypad and control station plate wiring to the drive controller.
10. Reinstall the field control and power wiring.
11. Close and secure the door with the quarter-turn fasteners.

Installation is complete. Return the MCC to service.

Cooling System Maintenance

⚠ DANGER
<p>HAZARD OF ELECTRIC SHOCK, BURN, OR EXPLOSION</p> <ul style="list-style-type: none">• Turn OFF all power supplying this equipment before working on or inside the motor control center.• Use a properly rated volt sensing device to check that all circuits are de-energized. Equipment must be de-energized before maintenance is performed. <p>Failure to observe these instructions will result in death or serious injury.</p>

NOTE: Before performing any service on the cooling system of the MCC ALTIVAR drive controller, remove the unit as described on the previous pages in Plug-on Unit Removal.

Cooling system air movers do not require any scheduled maintenance. Fan/impeller removal is only necessary when fan/impeller replacement is indicated by troubleshooting.

NOTE: All maintenance must be performed by qualified personnel.

Duct System Cleaning

To ensure proper ventilation of the MCC drive controller unit, clean the duct system a minimum of once per year—or more frequently if indicated by service conditions and your established maintenance schedule. To clean the duct system:

1. Remove the top duct cover by following the appropriate fan/impeller removal procedures for the type of operator mechanism installed on the unit. These procedures are listed on the following pages.
2. Vacuum all duct areas. Do not use compressed air; it will redistribute contaminants to other surfaces.
3. Vacuum all vented openings in the MCC drive controller unit door. Do not use compressed air; it will redistribute contaminants to other surfaces.

Definitions

Axial Fan—A fan with blades and motor in the center of the air flow.

Motorized Impeller (Squirrel Cage Fan)—An air mover that either draws in or exhausts air, and that changes the direction of the air flow at right angles.

Horizontal Operator Axial Fan Removal

For units with a horizontally mounted operating mechanism, remove the fan using this procedure. Retain all hardware for later replacement.

1. Remove the twin handle cam mechanism mechanism by removing its six screws (Figure 24).
2. Remove the top duct cover by removing its ten screws (Figure 25).
3. Viewing the unit from the top, remove the wires from the fan terminals (Figure 26). Locate and remove the two fan mounting screws and lift the fan through the top of the unit.

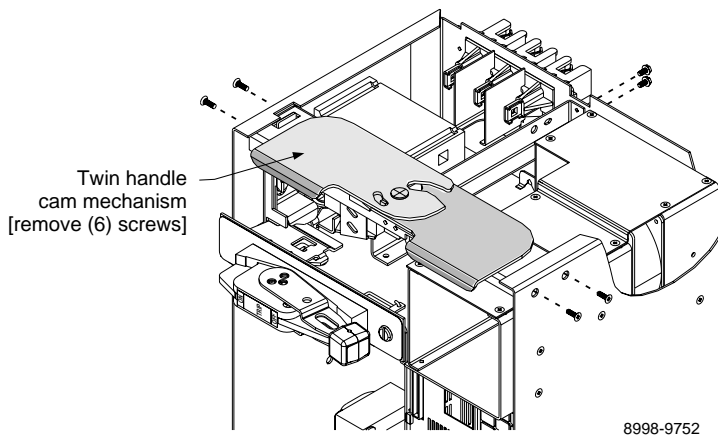

Figure 24: Twin Handle Cam Mechanism Removal (Horizontal Operator Mechanism)

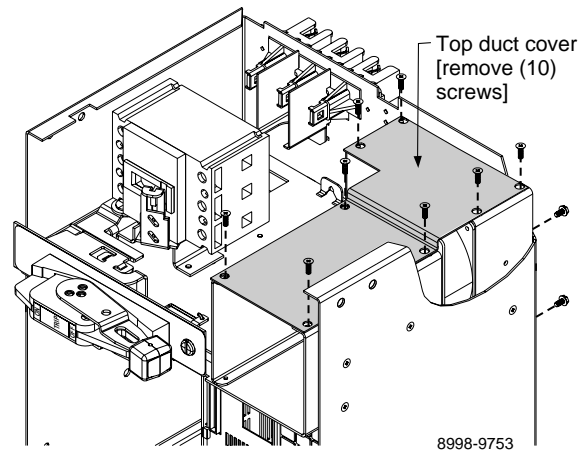

Figure 25: Top Duct Cover Removal (Horizontal Operator Mechanism)

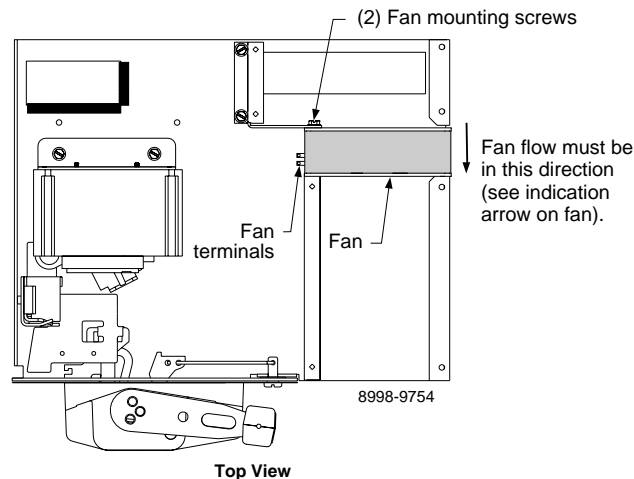

Figure 26: Fan Removal (Horizontal Operator Mechanism)

Horizontal Operator Axial Fan Installation

To install the fan, reverse steps 1 through 3 of **Horizontal Operator Axial Fan Removal**, above.

NOTE: Before installing a new fan, insert the mounting screws in the mounting holes of the fan body, and remove them. This action taps the mounting holes for ease of installation.

Vertical Operator Axial Fan Removal

For units with a vertically mounted operating mechanism, remove the fan using this procedure. Retain all hardware for later replacement.

1. Viewing the unit from the front, remove the block-off plate from the duct by removing its three mounting screws (Figure 27).

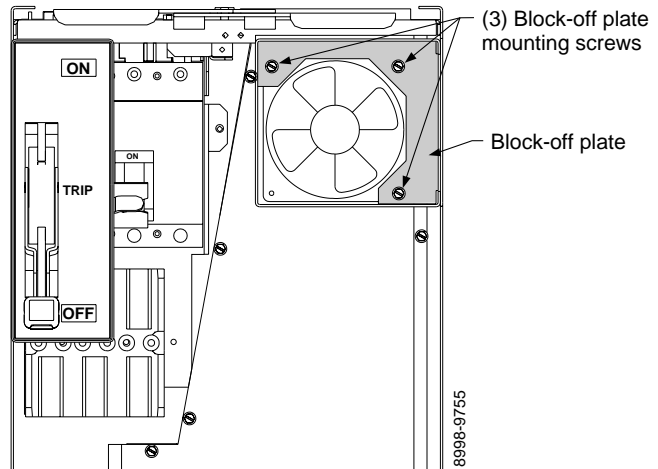

**Figure 27: Block-Off Plate Removal
(Vertical Operator Mechanism)**

2. Viewing the unit from the front, remove the two front mounting screws from the top duct cover above the fan (Figure 28).

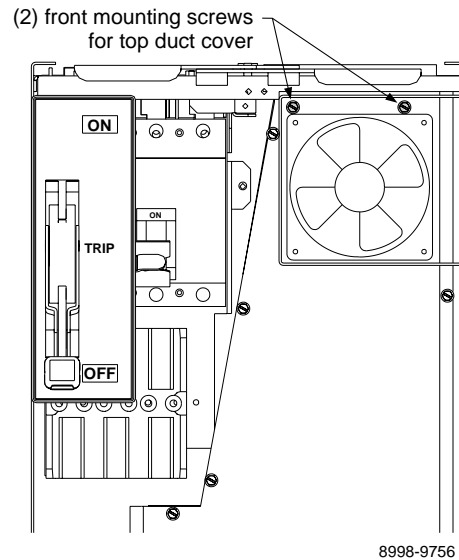

**Figure 28: Top Duct Cover Removal—Front Mounting Screws
(Vertical Operator Mechanism)**

3. Viewing the unit from the rear, remove the two rear mounting screws from the top duct cover (Figure 29 on page 22). Remove the top duct cover.

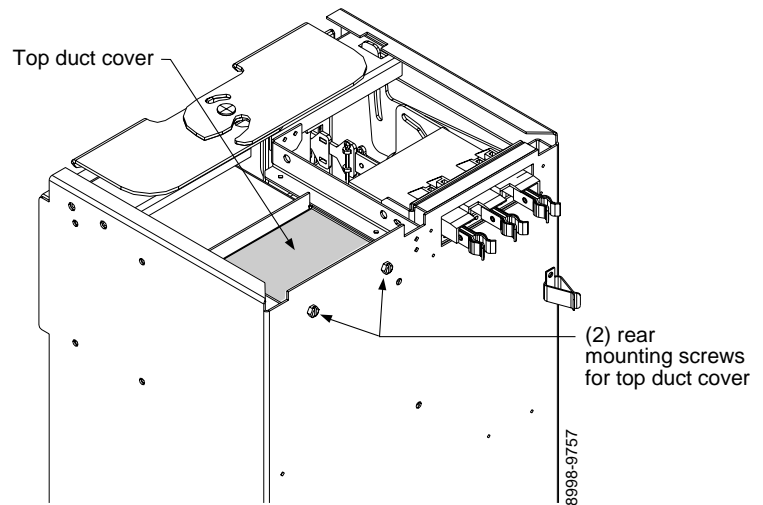

**Figure 29: Top Duct Cover Removal—Rear Mounting Screws
(Vertical Operator Mechanism)**

4. Viewing the unit from the top, remove the four fan mounting screws (see Figure 30).
5. Viewing the unit from the front, remove the wires from the fan terminals (see Figure 30). Remove the fan through the front of the duct.

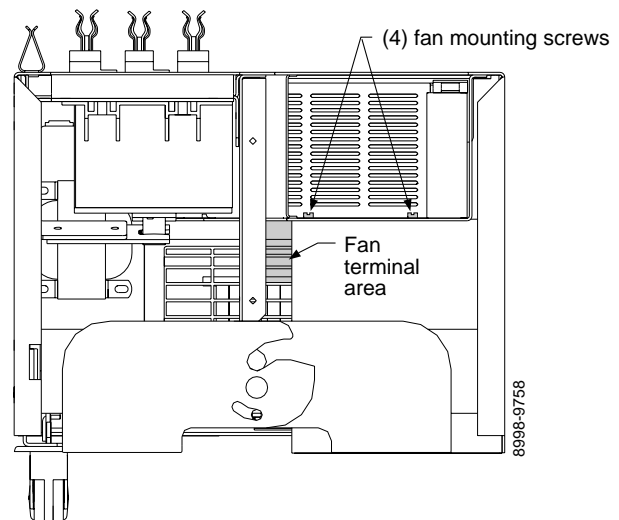

**Figure 30: Fan Removal
(Vertical Operator Mechanism—Top View)**

Vertical Operator Axial Fan Installation

To install the fan, reverse steps 1 through 5 of **Vertical Operator Axial Fan Removal**, above.

NOTE: Before installing a new fan, insert the mounting screws in the mounting holes of the fan body, and remove them. This action taps the mounting holes for ease of installation.

Motorized Impeller Removal

1. Remove the protective grill from the duct (Figure 31).
2. Remove the impeller electrical wiring from the terminal block (Figure 31).

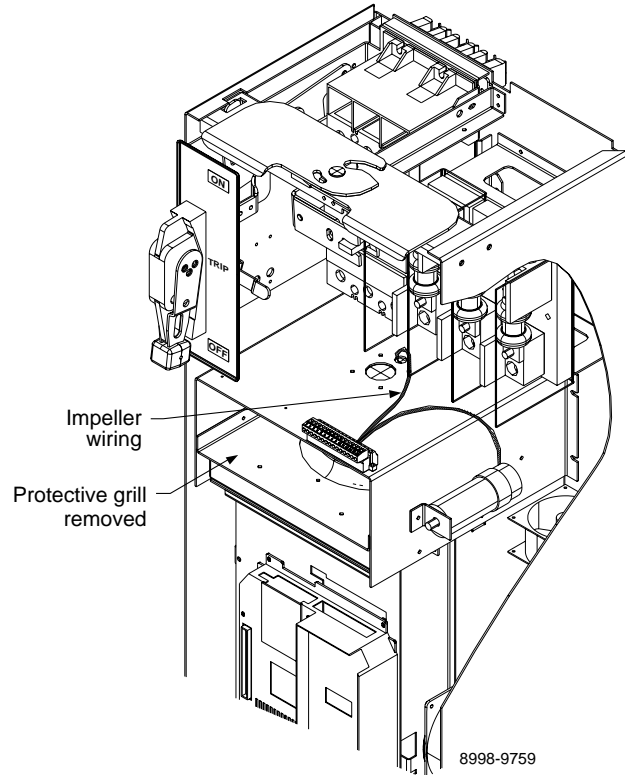

Figure 31: Impeller Wiring Removal

3. Remove the four screws from the top of the impeller duct housing (Figure 32).

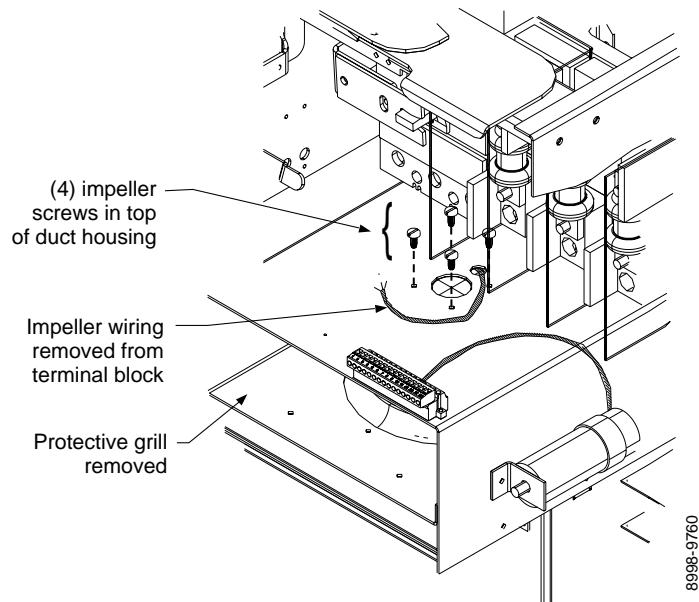

Figure 32: Impeller Screw Removal

4. Remove the motorized impeller through the front of the housing, carefully feeding the wires through the hole in the top of the housing (Figure 33).

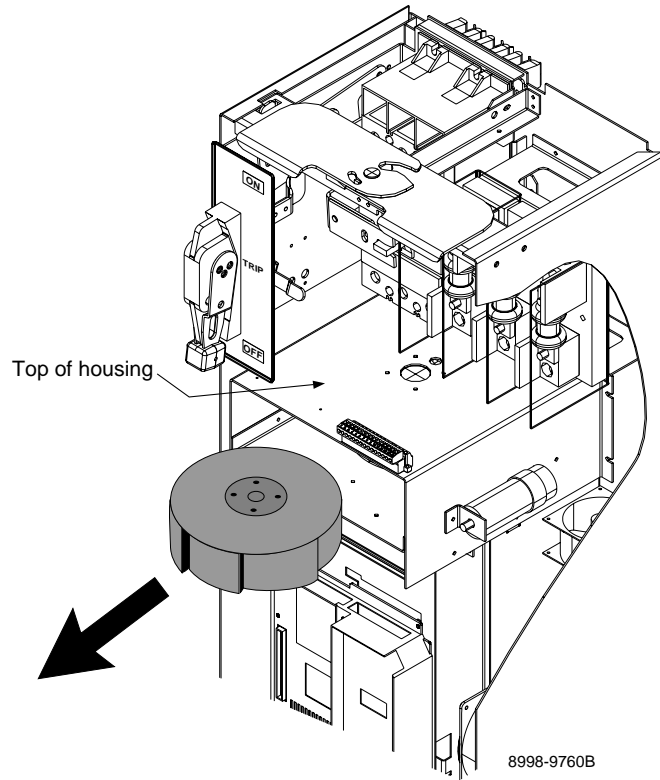

Figure 33: Motorized Impeller Removal

Motorized Impeller Installation

To install the impeller, reverse steps 1 through 4 of “Motorized Impeller Removal” on page 23.

Insulation Test

⚠ CAUTION

HAZARD OF EQUIPMENT DAMAGE

Disconnect all solid-state devices, capacitor units, and any other devices not designed to withstand megger voltages.

Failure to observe this instruction can result in injury or equipment damage.

Refer to the appropriate MCC instruction bulletin (Model 5 or Model 6) for MCC insulation test procedures.

Troubleshooting—Drive Overheating

The following flow chart demonstrates necessary steps to take if the drive overheats.

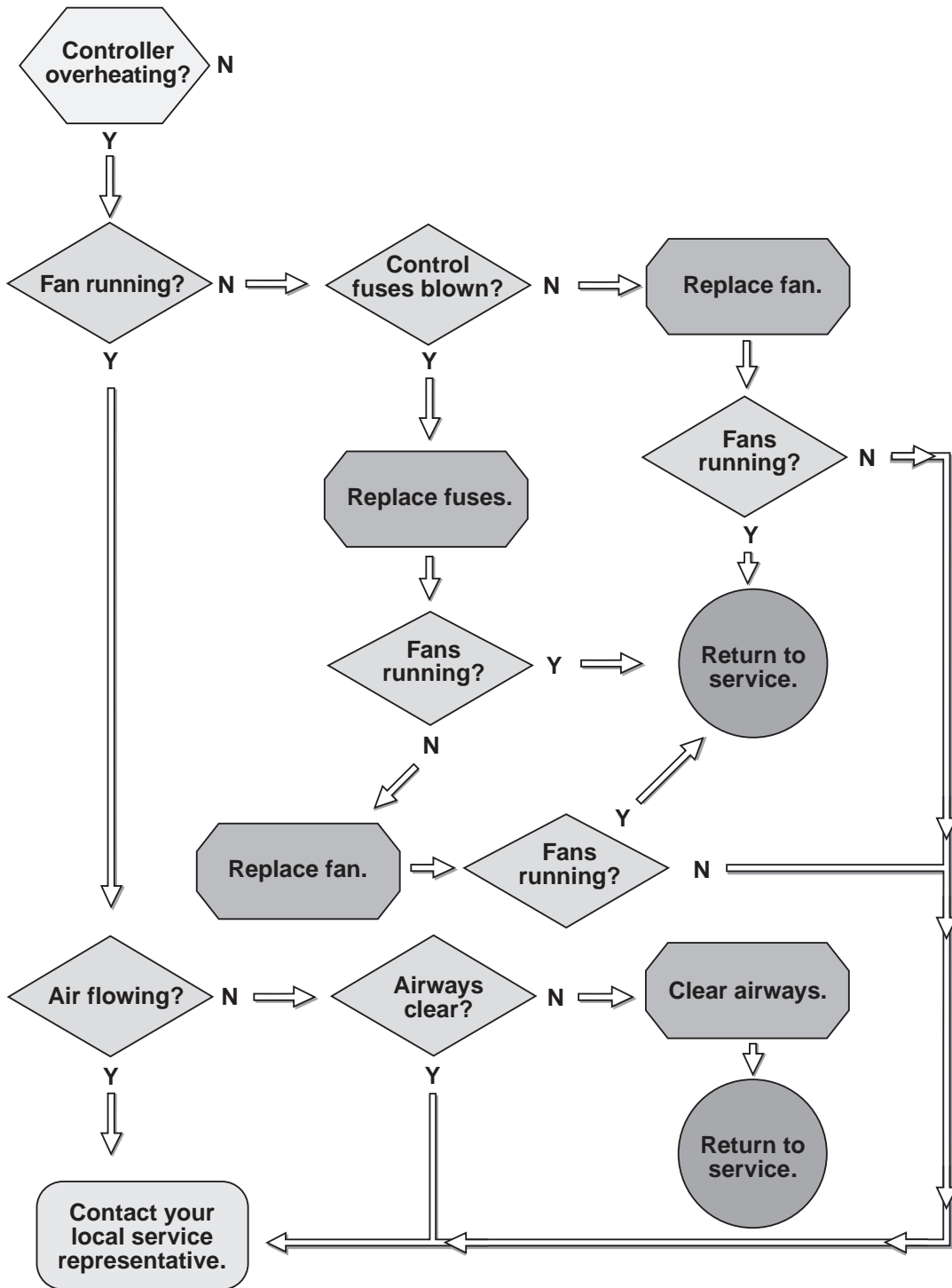

Troubleshooting—Drive Will Not Run

The following flow chart demonstrates necessary steps to take if the drive will not run.

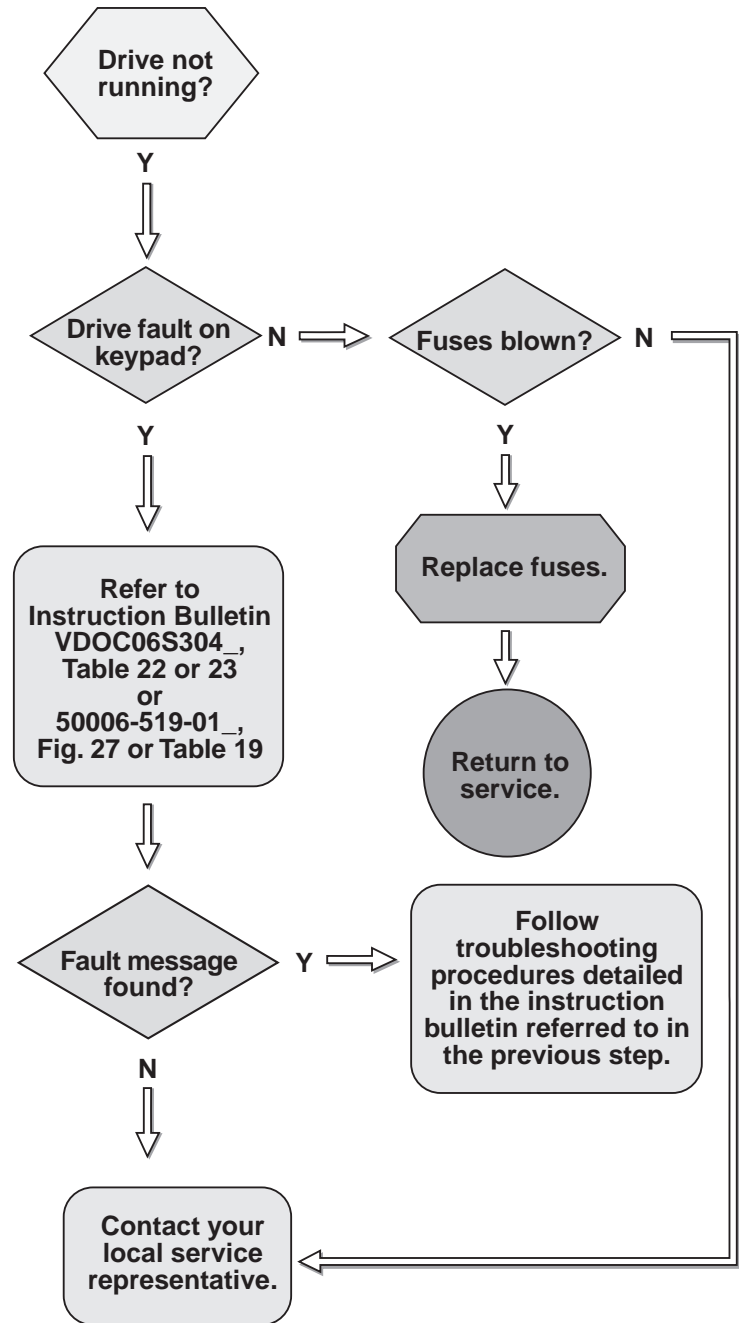

Spare Parts

This section details the spare parts available for ALTIVAR drive controller units in motor control centers. For spare parts specific to the ALTIVAR 66 drive controller, refer to Table 24 in the *ALTIVAR 66 Receiving, Installation, and Start-Up Instruction Bulletin* (VDOC06S304_) or Appendix C in the *ALTIVAR 56 User's Manual* (50006-519-01_). For power fuse recommendation and location, refer to Table 2 on page 12 of this manual.

Table 3: Disconnect Switch Assemblies (SW)

Description			Drive Controller	Square D Part Number
CT or VT (low noise) HP at 460 V	VT HP	Drive Frame Size		
1, 2, and 3	1, 2, and 3	1	ATV66U41N4U	40512-722-50
—	5	1	ATV66U54N4U	40512-722-50
5	7.5	1	ATV66U72N4U	40512-722-50
7.5	—	2	ATV66U90N4U	40512-722-50
—	10	2	ATV66U90N4U	40512-722-50
10	15	2	ATV66D12N4U	40512-722-50
15	—	3	ATV66D16N4U	80442-210-50
—	20	3	ATV66D16N4U	80442-210-50
20	25	3	ATV66D23N4U	80442-210-50
30	30	4	ATV66D33N4U	M6DSAFS100M
—	40	4	ATV66D33N4U	M6DSAFS100M
40	50	4	ATV66D46N4U	M6DSAFS100M

Table 4: Circuit Breaker Disconnect Assemblies (BKR)

Description			Drive Controller	Square D Part Number
CT or VT (low noise) HP	VT HP	Drive Frame Size		
1 and 2	1 and 2	1	ATV66U41N4U	GJL36007MO2
3	3	1	ATV66U41N4U	GJL36015MO3
—	5	1	ATV66U54N4U	GJL36015MO3
5	—	1	ATV66U72N4U	GJL36015MO3
—	7.5	1	ATV66U72N4U	GJL36030MO4
7.5	10	2	ATV66U90N4U	GJL36030MO4
10	—	2	ATV66D12N4U	GJL36030MO4
—	15	2	ATV66D12N4U	GJL36050MO5
15	20	3	ATV66D16N4U	80442-208-50
20	—	3	ATV66D23N4U	80442-208-50
—	25	3	ATV66D23N4U	80442-209-50
25	—	4	ATV66D33N4U	80442-209-50
30	30 and 40	4	ATV66D33N4U	M6DSAMG100M18Y532
40	—	4	ATV66D46N4U	M6DSAMG100M18Y532
—	50	4	ATV66D46N4U	M6DSAMG250M25Y532

Table 5: CL1 and CL2 Fuses

Description	Drive Controller	Replacement Fuse Catalog Number (Bussman)	Square D Part Number
FU	ATV66 All Sizes	KTK-R-3	25430-10300

Table 6: Fan Fuses

Description	Drive Controller	Replacement Fuse Catalog Number (Bussman)	Square D Part Number
PRI (FU)	ATV66 with 50 VA CPT	FNQ-R-1/4	25430-20025
	ATV66 with 100 VA CPT	FNQ-R-1/2	25430-20050
	ATV66 with 150 VA CPT	FNQ-R-3/4	25430-20074
	ATV66 with 300 VA CPT	FNQ-R-1-6/10	25430-20161
	ATV66 with 500 VA CPT	FNQ-R-2-8/10	25430-20281
SEC (FF)	ATV66 with 50 VA CPT	FNQ-R-1/2	25430-20050
	ATV66 with 100 VA CPT	FNQ-R-8/10	25430-20080
	ATV66 with 150 VA CPT	FNQ-R-1-1/4	25430-20126
	ATV66 with 300 VA CPT	FNQ-R-2-1/2	25430-20250
	ATV66 with 500 VA CPT	FNQ-R-4	25430-20400

Table 7: Bulbs

Description	Rating	Drive Controller	Square D Part Number
Red LED	24 Vdc	ATV66 All Sizes	25501-03043
Green LED	24 Vdc	ATV66 All Sizes	25501-03044
Yellow LED	24 Vdc	ATV66 All Sizes	25501-03045
Pilot Lamp	120 Vac	ATV66 All Sizes	DL1CE130

Table 8: Air Movers

Description	Size	CFM	Manufacturer	Manufacturer Part Number	Square D Part Number
Axial Fans (Fan 1, 2)	3.14 X 3.14	34	Comair-Rotron	SU2A5	26016-31001
	4.69 X 4.69	115	Comair-Rotron	MX2A3	26016-31529
Motorized Impeller (Fan 3)	7.48 diameter	365	EBM Industries	R2E190-AE50-29	26016-31532

Table 9: Pilot Devices

Description	Rating	Square D Part Number
Potentiometer (MSP)	2.5 Kohms	80442-273-01
MMIR (IR)	24 Vdc	80442-247-50

Table 10: Control Power Transformers (CPT)

Diagram Designation	Rating	Square D Part Number
(TRANS)	50 VA	9070EL1D9
	100 VA	9070EL2D9
	150 VA	9070EL3D9
	300 VA	9070KL300D9
	500 VA	9070K500D1





APPENDIX A—SAMPLE ALTIVAR PARAMETER SHEET

MENU INDEX NO.	PARAMETER NAME	SETTINGS BY MCC FACTORY
6.1	TORQUE TYPE	VARIABLE (VT)
6.2	COMMAND TYPE	2 WIRE (Maintained)
7.2	SPEED REF 1	AI1
7.2	SPEED REF 2	AI2 4-20mA
7.2	AUTO/MANUAL	YES, LOGIC IN:LI5 AUTO RUN = LI6
7.2	CONTROLLED STOP	BY LOGIC INPUT = LI7 ACTIVE STATE = LOW STOP TYPE = FREE
7.2	BYPASS	YES DEFINE I/O SEQUENCE INPUT = LI8 RUN OUT. COMMAND = R2
7.3	FAULT STATE	LO2
7.3	MOTOR SPEED	AO1 SELECT 0-20mA
7.4	FAULT RESET	LI4

APPENDIX B—FIELD WIRING TERMINATION DRAWINGS

**Table 11: Field Wire Termination Chart for Basic Frame Size 1
 ALTIVAR Drive Controller in Square D MCCs (see Figure 34)**
 1–5 hp at 460 Vac, Constant Torque (CT) and Variable Torque Low Noise (VTLN)
 1–7.5 hp at 460 Vac, Variable Torque (VT)

Termination Designation	Device	Torque (lb-in/N•m)	Maximum Wire Size (AWG/mm ²)	Wire Class	Noise Class	Voltage Class	Applicable HP Ratings
T1, T2, T3	Converter Fuse Block	20/—	#10/—	75 °C CU	SW2	600 V	All
L1, L2, L3	Power Converter	7/0.76	#10 / 2.5	75 °C CU	SW2	600 V	All
T1, T2, T3	Power Converter	7/0.76	#10 / 2.5	75 °C CU	PW1	600 V	All
PA, PB	Power Converter	7/0.76	#10 / 2.5	75 °C CU	PW1	600 V	All
Any	Power Converter J1	3.5 / 0.4	#14 / 2.5	75 °C CU	SW1	150 V / 300 V	All
Any	Power Converter J12, J22, J24	3.5 / 0.4	#14 / 2.5	75 °C CU	QW2	30 V	All
Any	Power Converter J13, J23	3.5 / 0.4	#14 / 2.5	75 °C CU	QW1	30 V	All
X1, X2, S1, S2, 1, 2, 3 through n	Terminal Block FTB	5 / 0.6	#12 / 2.5	75 °C CU	SW1	150 V	All
C1, C2, C3 through Cn	Terminal Block FTB	5 / 0.6	#12 / 2.5	75 °C CU	QW1	30 V	All
D1, D2, D3 through Dn	Terminal Block FTB	5 / 0.6	#12 / 2.5	75 °C CU	QW2	30 V	All

	QW1 (see Note 1)
	QW2 (see Note 1)
	SW1 (see Note 1)
	SW2, PW1 (see Note 1)

Notes:

1. For description, refer to **Wire Routing and Interconnection** in Section 4.
2. Arrange conductor groups depth-wise within unit and structure to maximize separation of each noise class.

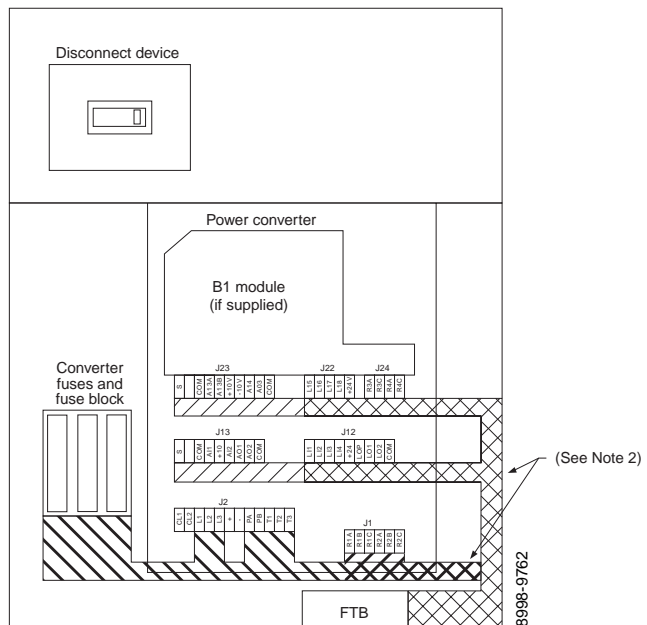

Figure 34: Field Wire Termination Diagram for Basic Frame Size 1 ALTIVAR Drive Controller in Square D MCCs

**Table 12: Field Wire Termination Chart for Frame Size 1
 ALTIVAR Drive Controller with Extended Options in Square D MCCs
 (see Figure 35 on page 32)**
 1–5 hp at 460 Vac, Constant Torque (CT) and Variable Torque Low Noise (VTLN)
 1–7.5 hp at 460 Vac, Variable Torque (VT)

Termination Designation	Device	Torque (lb-in/ N•m)	Maximum Wire Size (AWG/mm ²)	Wire Class	Noise Class	Voltage Class	Applicable HP Ratings
T1, T2, T3	Converter Fuse Block	20/—	#10/—	75 °C CU	SW2	600 V	All
L1, L2, L3	Power Converter	7/0.76	#10 / 2.5	75 °C CU	SW2	600 V	All
T1, T2, T3	Power Converter	7/0.76	#10 / 2.5	75 °C CU	PW1	600 V	All
PA, PB	Power Converter	7/0.76	#10 / 2.5	75 °C CU	PW1	600 V	All
T1, T2, T3	Iso/Bypass Starter or Isolation Contactor (if applicable)	15/—	#8/—	75 °C CU	PW1	600 V	All
L1, L2, L3	Line Contactor (if applicable)	15/—	#8/—	75 °C CU	SW2	600 V	All
Any	Power Converter J1	3.5 / 0.4	#14 / 2.5	75 °C CU	SW1	150 V / 300 V	All
Any	Power Converter J12, J22, J24	3.5 / 0.4	#14 / 2.5	75 °C CU	QW2	30 V	All
Any	Power Converter J13, J23	3.5 / 0.4	#14 / 2.5	75 °C CU	QW1	30 V	All
X1, X2, S1, S2, 1, 2, 3 through n	Terminal Block FTB	5 / 0.6	#12 / 2.5	75 °C CU	SW1	150 V	All
C1, C2, C3 through Cn	Terminal Block FTB	5 / 0.6	#12 / 2.5	75 °C CU	QW1	30 V	All
D1, D2, D3 through Dn	Terminal Block FTB	5 / 0.6	#12 / 2.5	75 °C CU	QW2	30 V	All

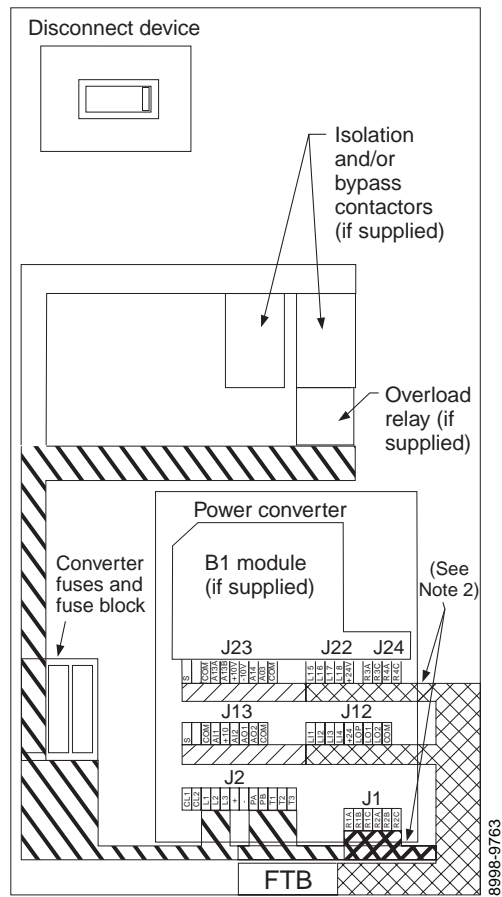
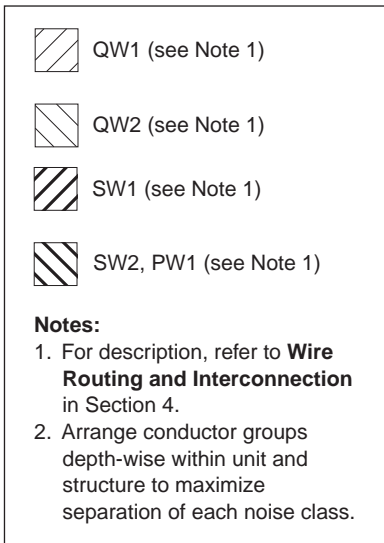

Figure 35: Field Wire Termination Diagram for Frame Size 1 ALTIVAR Drive Controller with Extended Options in Square D MCCs

Table 13: Field Wire Termination Chart for Basic Frame Size 2 ALTIVAR Drive Controller in Square D MCCs (see Figure 36 on page 34)
 7.5–10 hp at 460 Vac, Constant Torque (CT) and
 Variable Torque Low Noise (VTLN)
 10–15 hp at 460 Vac, Variable Torque (VT)

Termination Designation	Device	Torque (lb-in / N•m)	Maximum Wire Size (AWG / mm ²)	Wire Class	Noise Class	Voltage Class	Applicable HP Ratings
T1, T2, T3	Converter Fuse Block	20 / —	#10 / —	60 °C CU-AL	SW2	600 V	All Above
L1, L2, L3	Power Converter	36 / 4	#6 / 10	75 °C CU	SW2	600 V	All Above
T1, T2, T3	Power Converter	36 / 4	#6 / 10	75 °C CU	PW1	600 V	All Above
PA, PB	Power Converter	36 / 4	#6 / 10	75 °C CU	PW1	600 V	All Above
Any	Power Converter J1	3.5 / 0.4	#14 / 2.5	75 °C CU	SW1	150 V / 300 V	All Above
Any	Power Converter J12, J22, J24	3.5 / 0.4	#14 / 2.5	75 °C CU	QW2	30 V	All Above
Any	Power Converter J13, J23	3.5 / 0.4	#14 / 2.5	75 °C CU	QW1	30 V	All Above
X1, X2, S1, S2, 1, 2, 3 through n	Terminal Block FTB	5 / 0.6	#12 / 2.5	75 °C CU	SW1	150 V	All Above
C1, C2, C3 through Cn	Terminal Block FTB	5 / 0.6	#12 / 2.5	75 °C CU	QW1	30 V	All Above
D1, D2, D3 through Dn	Terminal Block FTB	5 / 0.6	#12 / 2.5	75 °C CU	QW2	30 V	All Above

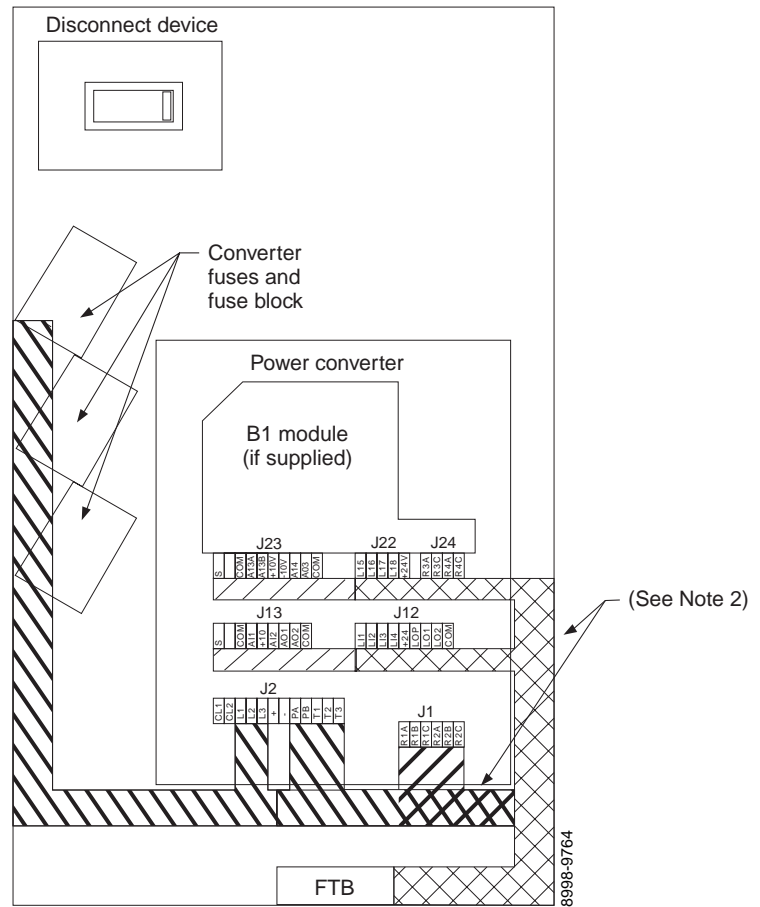
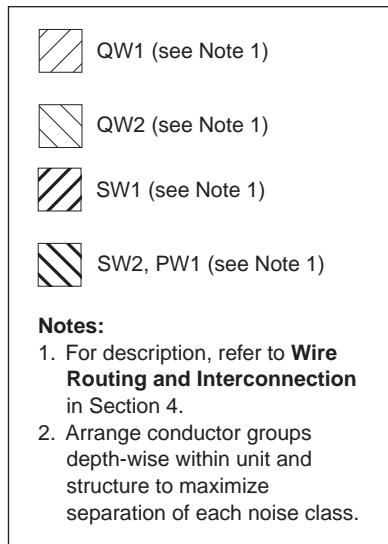

Figure 36: Field Wire Termination Diagram for Basic Frame Size 2 ALTIVAR Drive Controller in Square D MCCs

Table 14: Field Wire Terminations for Frame Size 2 ALTIVAR Drive Controller with Extended Options in MCCs (see Figure 37 on page 36)
 7.5–10 hp at 460 Vac, Constant Torque (CT) and
 Variable Torque Low Noise (VTLN)
 10–15 hp at 460 Vac, Variable Torque (VT)

Termination Designation	Device	Torque (lb-in / N•m)	Maximum Wire Size (AWG / mm ²)	Wire Class	Noise Class	Voltage Class	Applicable HP Ratings
T1, T2, T3	Converter Fuse Block	20 / —	#10 / —	60 °C CU	SW2	600 V	All Above
L1, L2, L3	Power Converter	36 / 4	#6 / 10	75 °C CU	SW2	600 V	All Above
T1, T2, T3	Power Converter	36 / 4	#6 / 10	75 °C CU	PW1	600 V	All Above
PA, PB	Power Converter	36 / 4	#6 / 10	75 °C CU	PW1	600 V	All Above
T1, T2, T3	Iso/Bypass Starter or Isolation Contactor (if applicable)	15 / —	#8 / —	75 °C CU	PW1	600 V	100–150 hp
L1, L2, L3	Line Contactor (if applicable)	15 / —	#8 / —	75 °C CU	SW2	600 V	7.5 & 10 hp CT 7.5 & 10 hp VTLN 10 hp VT
Any	Power Converter J1	20 / —	#6 / —	75 °C CU	SW2	600 V	15 hp VT
Any	Power Converter J12, J22, J24	3.5 / 0.4	#14 / 2.5	75 °C CU	SW1	150 V / 300 V	All Above
Any	Power Converter J13, J23	3.5 / 0.4	#14 / 2.5	75 °C CU	QW2	30 V	All Above
Any	Power Converter J13, J23	3.5 / 0.4	#14 / 2.5	75 °C CU	QW1	30 V	All Above
X1, X2, S1, S2, 1, 2, 3 through n	Terminal Block FTB	5 / 0.6	#12 / 2.5	75 °C CU	SW1	150 V	All Above
C1, C2, C3 through Cn	Terminal Block FTB	5 / 0.6	#12 / 2.5	75 °C CU	QW1	30 V	All Above
D1, D2, D3 through Dn	Terminal Block FTB	5 / 0.6	#12 / 2.5	75 °C CU	QW2	30 V	All Above

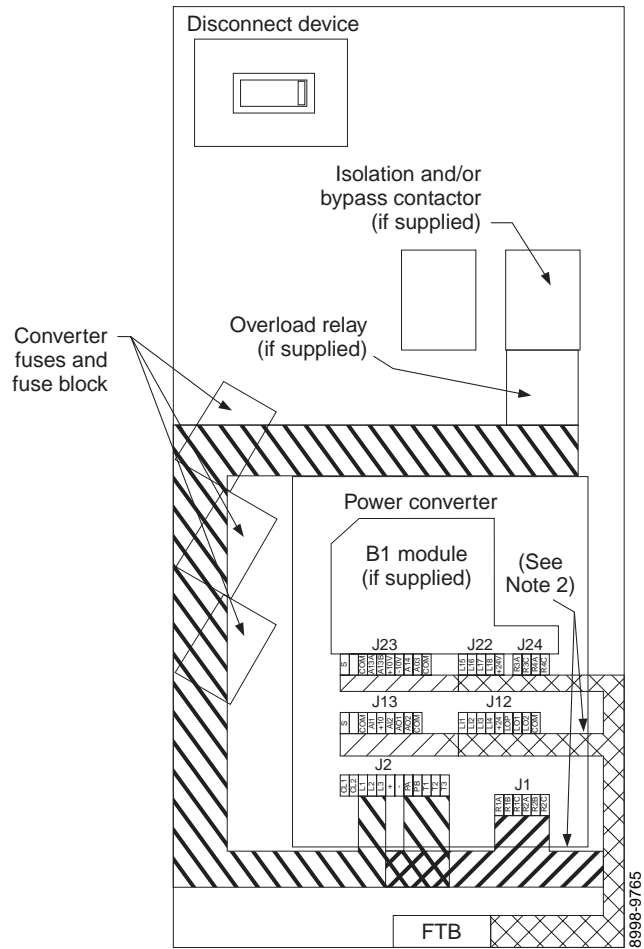
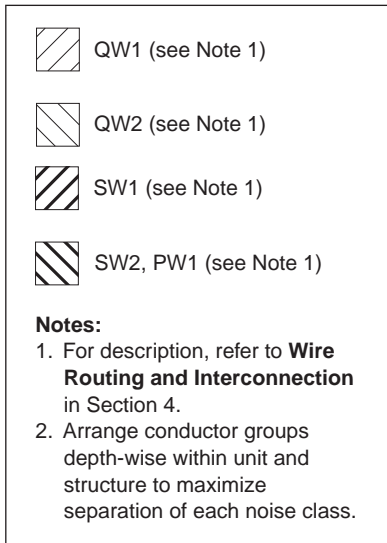

Figure 37: Field Wire Termination Diagram for Frame Size 2 ALTIVAR Drive Controller with Extended Options in Square D MCCs

Table 15: Field Wire Termination Chart for Basic Frame Size 3 ALTIVAR Drive Controller in Square D MCCs (see Figure 38 on page 38)
 15–20 hp at 460 Vac, Constant Torque (CT) and Variable Torque Low Noise (VTLN)
 20–25 hp at 460 Vac, Variable Torque (VT)

Termination Designation	Device	Torque (lb-in / N•m)	Maximum Wire Size (AWG / mm ²)	Wire Class	Noise Class	Voltage Class	Applicable HP Ratings
T1, T2, T3	Converter Fuse Block	50 / — 45 / — 40 / —	#2/0—#30 / — #4—#6 / — #8 / —	60 °C CU-AL	SW2	600 V	All Above
L1, L2, L3	Power Converter	18 / 2	#4 / 10	75 °C CU	SW2	600 V	All Above
T1, T2, T3	Power Converter	18 / 2	#4 / 10	75 °C CU	PW1	600 V	All Above
PA, PB	Power Converter	11 / 1.2	#8 / 6	75 °C CU	PW1	600 V	All Above
Any	Power Converter J1	3.5 / 0.4	#14 / 2.5	75 °C CU	SW1	150 V / 300 V	All Above
Any	Power Converter J12, J22, J24	3.5 / 0.4	#14 / 2.5	75 °C CU	QW2	30 V	All Above
Any	Power Converter J13, J23	3.5 / 0.4	#14 / 2.5	75 °C CU	QW1	30 V	All Above
X1, X2, S1, S2, 1, 2, 3 through n	Terminal Block FTB	5 / 0.6	#12 / 2.5	75 °C CU	SW1	150 V	All Above
C1, C2, C3 through Cn	Terminal Block FTB	5 / 0.6	#12 / 2.5	75 °C CU	QW1	30 V	All Above
D1, D2, D3 through Dn	Terminal Block FTB	5 / 0.6	#12 / 2.5	75 °C CU	QW2	30 V	All Above

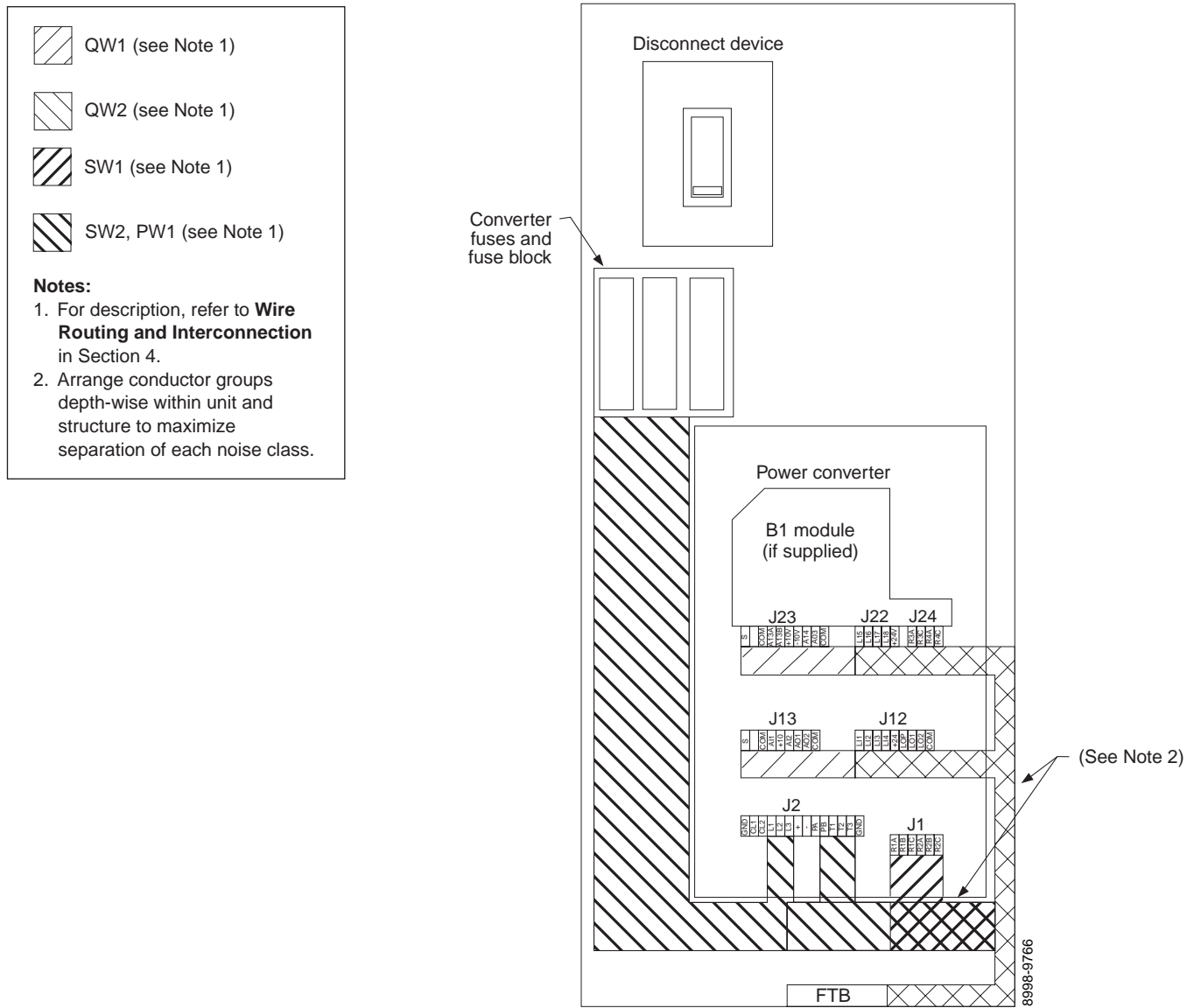

Figure 38: Field Wire Termination Diagram for Basic Frame Size 3 ALTIVAR Drive Controller in Square D MCCs

Table 16: Field Wire Terminations for Frame Size 3 ALTIVAR Drive Controller with Extended Options in MCCs (see Figure 39 on page 40)
 15–20 hp at 460 Vac, Constant Torque (CT) and
 Variable Torque Low Noise (VTLN)
 20–25 hp at 460 Vac, Variable Torque (VT)

Termination Designation	Device	Torque (lb-in / N•m)	Maximum Wire Size (AWG / mm ²)	Wire Class	Noise Class	Voltage Class	Applicable HP Ratings
T1, T2, T3	Converter Fuse Block	50 / — 45 / — 40 / —	#2/0–#30 / — #4–#6 / — #8 / —	60 °C CU-AL	SW2	600 V	All Above
L1, L2, L3	Power Converter	18 / 2	#4 / 10	75 °C CU	SW2	600 V	All Above
T1, T2, T3	Power Converter	18 / 2	#4 / 10	75 °C CU	PW1	600 V	All Above
PA, PB	Power Converter	11 / 1.2	#8 / 6	75 °C CU	PW1	600 V	All Above
T1, T2, T3	Iso/Bypass Starter or Isolation Contactor (if applicable)	15 / — 20 / — 35 / —	#8 / — #6 / — #3 / —	75 °C CU	PW1	600 V	15 hp CT & VTLN 20 hp CT, VTLN & VT 25 hp VT
L1, L2, L3	Line Contactor (if applicable)	15 / — 20 / —	#8 / — #6 / —	75 °C CU	SW2 SW2	600 V 600 V	15 & 20 hp CT & VTLN 25 hp VT
Any	Power Converter J1	3.5 / 0.4	#14 / 2.5	75 °C CU	SW1	150 V / 300 V	All Above
Any	Power Converter J12, J22, J24	3.5 / 0.4	#14 / 2.5	75 °C CU	QW2	30 V	All Above
Any	Power Converter J13, J23	3.5 / 0.4	#14 / 2.5	75 °C CU	QW1	30 V	All Above
X1, X2, S1, S2, 1, 2, 3 through n	Terminal Block FTB	5 / 0.6	#12 / 2.5	75 °C CU	SW1	150 V	All Above
C1, C2, C3 through Cn	Terminal Block FTB	5 / 0.6	#12 / 2.5	75 °C CU	QW1	30 V	All Above
D1, D2, D3 through Dn	Terminal Block FTB	5 / 0.6	#12 / 2.5	75 °C CU	QW2	30 V	All Above

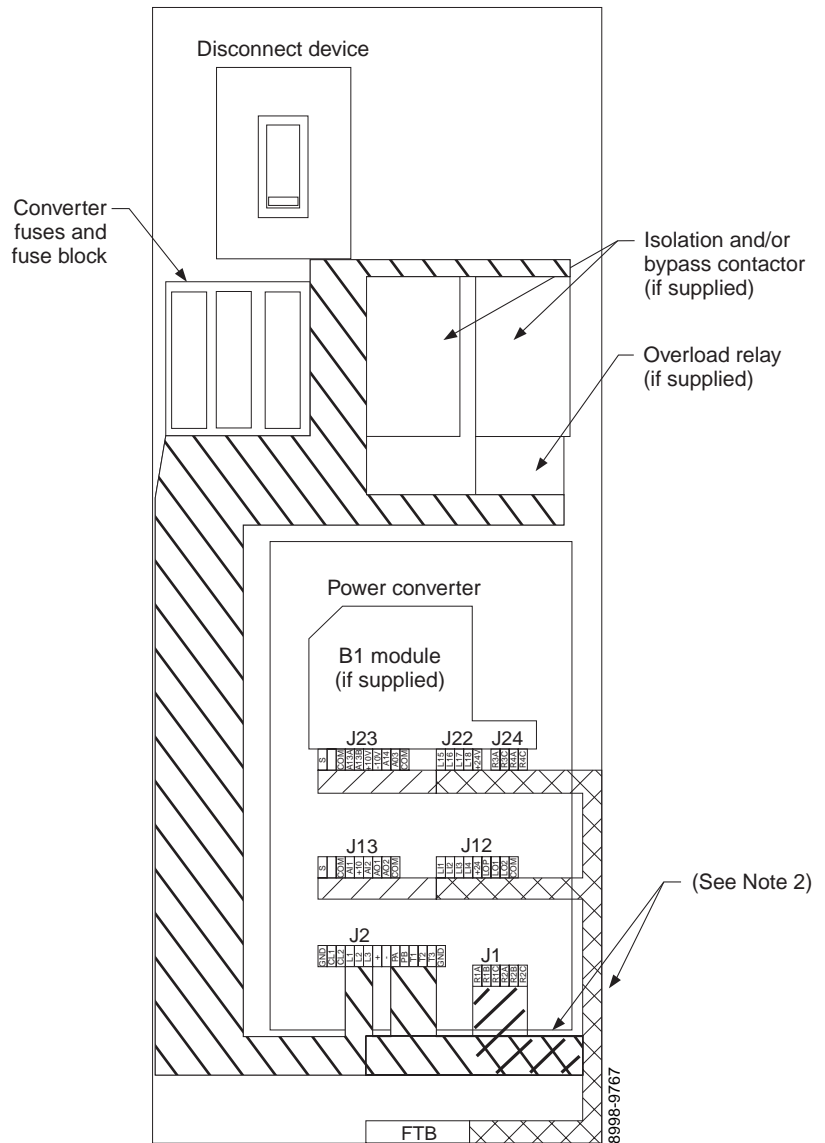
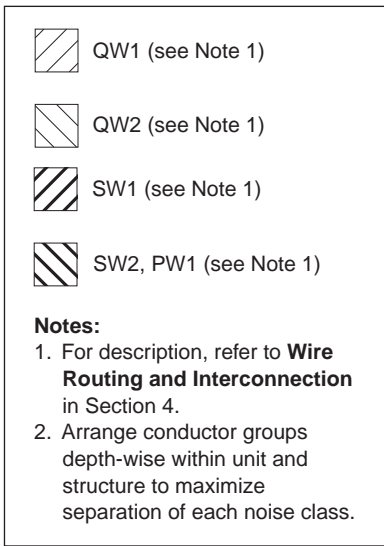





Figure 39: Field Wire Termination Diagram for Frame Size 3 ALTIVAR Drive Controller with Extended Options in Square D MCCs

Table 17: Field Wire Termination Chart for Basic Frame Size 4
ALTIVAR Drive Controller in Square D MCCs (see Figure 40 on page 42)
 25–40 hp at 460 Vac, Constant Torque (CT) and
 Variable Torque Low Noise (VTLN)
 30–50 hp at 460 Vac, Variable Torque (VT)

Termination Designation	Device	Torque (lb-in / N•m)	Maximum Wire Size (AWG / mm ²)	Wire Class	Noise Class	Voltage Class	Applicable HP Ratings
T1, T2, T3	Converter Fuse Block	375 / —	250 kcmil	60°/75 °C CU-AL	SW2	600 V	All Above
L1, L2, L3	Power Converter	27 / 3	#2/0 / 35	75 °C CU	SW2	600 V	All Above
T1, T2, T3	Power Converter	27 / 3	#2/0 / 35	75 °C CU	PW1	600 V	All Above
PA, PB	Power Converter	18 / 2	#4 / 16	75 °C CU	PW1	600 V	All Above
Any	Power Converter J1	3.5 / 0.4	#14 / 2.5	75 °C CU	SW1	150 V / 300 V	All Above
Any	Power Converter J12, J22, J24	3.5 / 0.4	#14 / 2.5	75 °C CU	QW2	30 V	All Above
Any	Power Converter J13, J23	3.5 / 0.4	#14 / 2.5	75 °C CU	QW1	30 V	All Above
X1, X2, S1, S2, 1, 2, 3 through n	Terminal Block FTB	5 / 0.6	#12 / 2.5	75 °C CU	SW1	150 V	All Above
C1, C2, C3 through Cn	Terminal Block FTB	5 / 0.6	#12 / 2.5	75 °C CU	QW1	30 V	All Above
D1, D2, D3 through Dn	Terminal Block FTB	5 / 0.6	#12 / 2.5	75 °C CU	QW2	30 V	All Above

	QW1 (see Note 1)
	QW2 (see Note 1)
	SW1 (see Note 1)
	SW2, PW1 (see Note 1)

Notes:

1. For description, refer to **Wire Routing and Interconnection** in Section 4.
2. Arrange conductor groups depth-wise within unit and structure to maximize separation of each noise class.

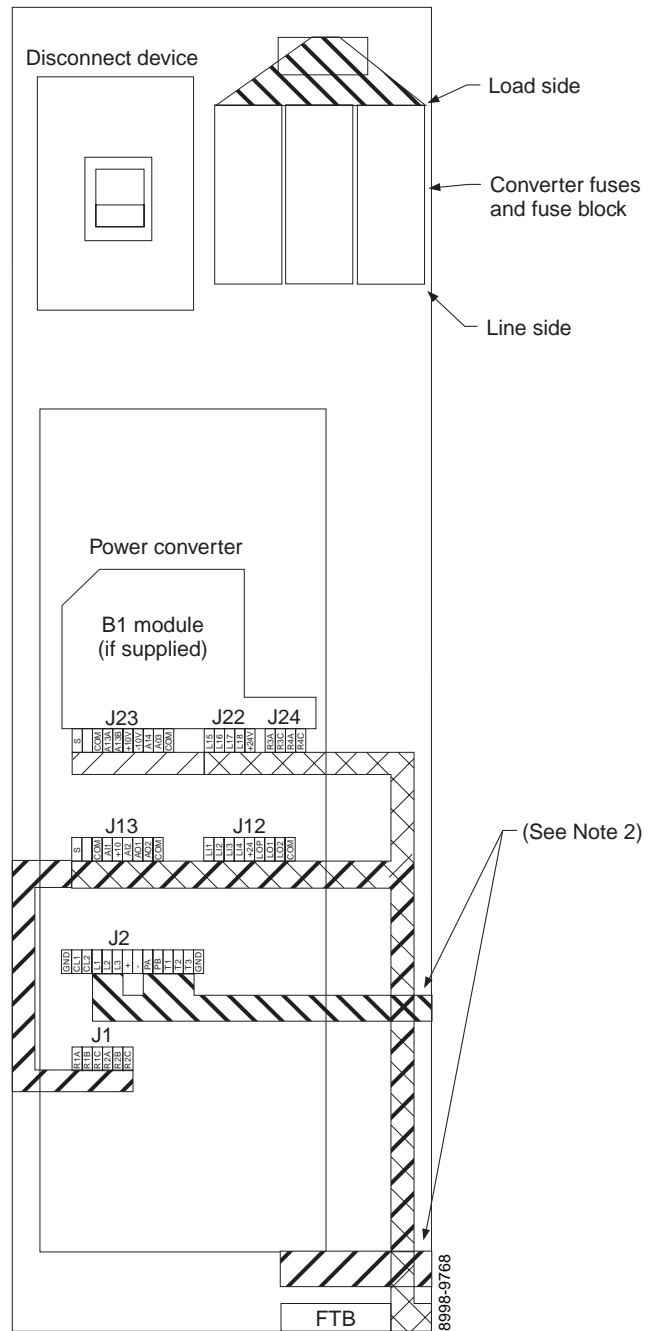

**Figure 40: Field Wire Termination Diagram
 for Basic Frame Size 4 ALTIVAR
 Drive Controller in Square D MCCs**

Table 18: Field Wire Terminations for Frame Size 4 ALTIVAR Drive Controller with Extended Options in MCCs (see Figure 41 on page 44)
 25–40 hp at 460 Vac, Constant Torque (CT) and
 Variable Torque Low Noise (VTLN)
 30–50 hp at 460 Vac, Variable Torque (VT)

Termination Designation	Device	Torque (lb-in / N•m)	Maximum Wire Size (AWG / mm ²)	Wire Class	Noise Class	Voltage Class	Applicable HP Ratings
T1, T2, T3	Converter Fuse Block	375 / —	250 kcmil	60°/75 °C CU-AL	SW2	600 V	All Above
L1, L2, L3	Power Converter	27 / 3	#2/0 / 35	75 °C CU	SW2	600 V	All Above
T1, T2, T3	Power Converter	27 / 3	#2/0 / 35	75 °C CU	PW1	600 V	All Above
PA, PB	Power Converter	18 / 2	#4 / 16	75 °C CU	PW1	600 V	All Above
T1, T2, T3	Iso/Bypass Starter or Isolation Contactor (if applicable)		#3 / —	75 °C CU	PW1	600 V	All Above
			#2 / —	75 °C CU			
L1, L2, L3	Line Contactor (if applicable)		#3 / —	75 °C CU	SW2	600 V	30 & 40 hp CT, VTLN & VT 50 hp VT
			#2 / —	75 °C CU		600 V	
Any	Power Converter J1	3.5 / 0.4	#14 / 2.5	75 °C CU	SW1	150 V / 300 V	All Above
Any	Power Converter J12, J22, J24	3.5 / 0.4	#14 / 2.5	75 °C CU	QW2	30 V	All Above
Any	Power Converter J13, J23	3.5 / 0.4	#14 / 2.5	75 °C CU	QW1	30 V	All Above
X1, X2, S1, S2, 1, 2, 3 through n	Terminal Block FTB	5 / 0.6	#12 / 2.5	75 °C CU	SW1	150 V	All Above
C1, C2, C3 through Cn	Terminal Block FTB	5 / 0.6	#12 / 2.5	75 °C CU	QW1	30 V	All Above
D1, D2, D3 through Dn	Terminal Block FTB	5 / 0.6	#12 / 2.5	75 °C CU	QW2	30 V	All Above

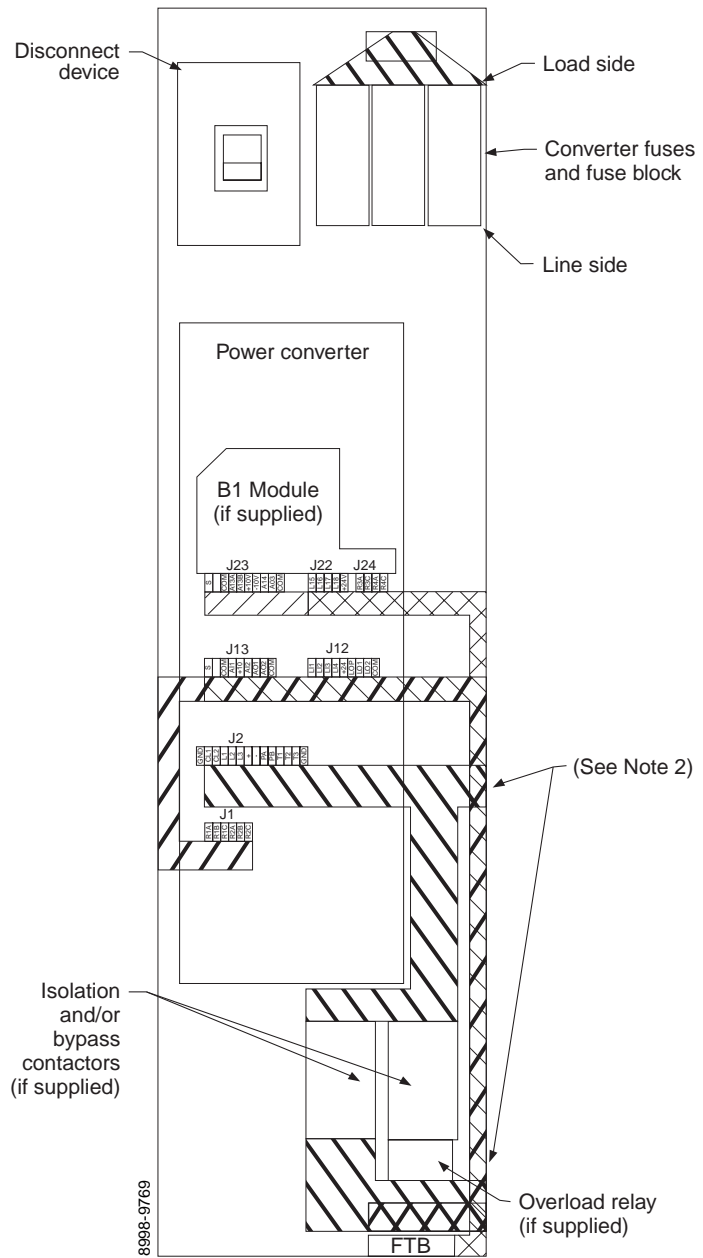
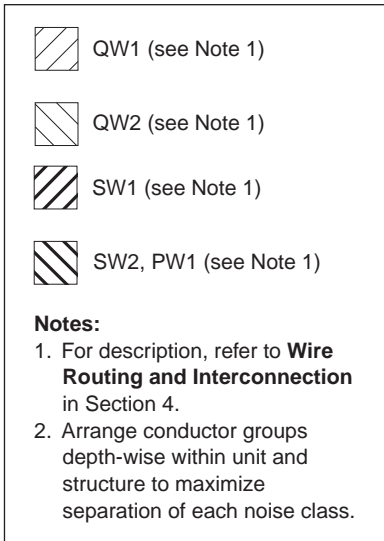



Figure 41: Field Wire Termination Diagram for Frame Size 4 ALTIVAR Drive Controller with Extended Options in Square D MCCs

Square D Company
1990 Sandifer Blvd.
Seneca, SC 29678 USA
(864) 882-2414
www.squared.com

Square D and  are registered trademarks of Square D Company.
COMPAC is a trademark of Square D.

ALTIVAR is a trademark of Telemecanique S.A. or its successor-in-interest, Schneider Electric S.A.
All other trademarks are the intellectual property of their respective companies.

Electrical equipment should be serviced only by qualified electrical maintenance personnel. No
responsibility is assumed by Square D for any consequences arising out of the use of this material.

Bulletin No. 80442-291-01B April 1998 © 1998 Square D All Rights Reserved.
Replaces 80442-291-01A, dated August 1996.



California Proposition 65 Warning—Nickel Compounds and Bisphenol A (BPA)

Advertencia de la Proposición 65 de California— compuestos de níquel y Bisfenol A (BPA)

Avertissement concernant la Proposition 65 de Californie— composés de nickel et Bisphénol A (BPA)

⚠️ WARNING: This product can expose you to chemicals including Nickel compounds, which are known to the State of California to cause cancer, and Bisphenol A (BPA), which is known to the State of California to cause birth defects or other reproductive harm. For more information go to www.P65Warnings.ca.gov.

⚠️ ADVERTENCIA: Este producto puede exponerle a químicos incluyendo compuestos de níquel, que son conocidos por el Estado de California como causantes de cáncer, y Bisfenol A (BPA), que es conocido por el Estado de California como causante de defectos de nacimiento u otros daños reproductivos. Para mayor información, visite www.P65Warnings.ca.gov.

⚠️ AVERTISSEMENT: Ce produit peut vous exposer à des agents chimiques, y compris composés de nickel, identifiés par l'État de Californie comme pouvant causer le cancer, et Bisphénol A (BPA) reconnus par l'État de Californie comme pouvant causer des malformations congénitales ou autres troubles de l'appareil reproducteur. Pour de plus amples informations, prière de consulter www.P65Warnings.ca.gov.

All trademarks are the property of Schneider Electric SE, its subsidiaries, and affiliated companies.

Schneider Electric USA, Inc.
800 Federal Street
Andover, MA 01810 USA
888-778-2733
www.schneider-electric.us

Todas las marcas comerciales son propiedad de Schneider Electric SE, sus filiales y compañías afiliadas.

Importado en México por:
Schneider Electric México, S.A. de C.V.
Av. Ejercito Nacional No. 904
Col. Palmas, Polanco 11560 México, D.F.
55-5804-5000
www.schneider-electric.com.mx

Toutes les marques commerciales sont la propriété de Schneider Electric SE, ses filiales et compagnies affiliées.

Schneider Electric Canada, Inc.
5985 McLaughlin Road
Mississauga, ON L5R 1B8 Canada
800-565-6699
www.schneider-electric.ca