

# SQUARE D®

## CLASS 9423, TYPE M6

### 6" VAULT HANDLE DOOR CLOSING MECHANISM

For Use On Single Or Multiple-Door Enclosures  
With 3/4" Deep Doors and 40"-60" High Door Openings

Instruction Sheet  
30072-303-29-E  
NOVEMBER 1986

#### GENERAL

This kit is designed for use:

- on NEMA 1 or 12 enclosures,
- on doors constructed of 11-14 gage material,
- on doors hinged on left or right hand side,
- with or without Class 9422, Type A1 Universal Operating Handle,
- with or without Class 9423, Type M5 Master Door Interlock,
- with or without Class 9423, Type M2 Multi-door Interlock,
- with or without door closing on center channel.

#### ENCLOSURE

Enclosures must be constructed per this instruction sheet. Determine enclosure configuration and construct channels and flanges using figures 3 thru 6. Before constructing enclosure, refer to the individual instruction sheet for each Square D Class 9422 Disconnect Operating Mechanism, and Operating Handle; and each Class 9423 enclosure accessory which will be installed to insure minimum dimensions are maintained.

#### CONSTRUCTION

**NOTE:** All dimensions on this Instruction Sheet are based on a 3/4" Door Overlap. This is the min-Door Overlap dimension.

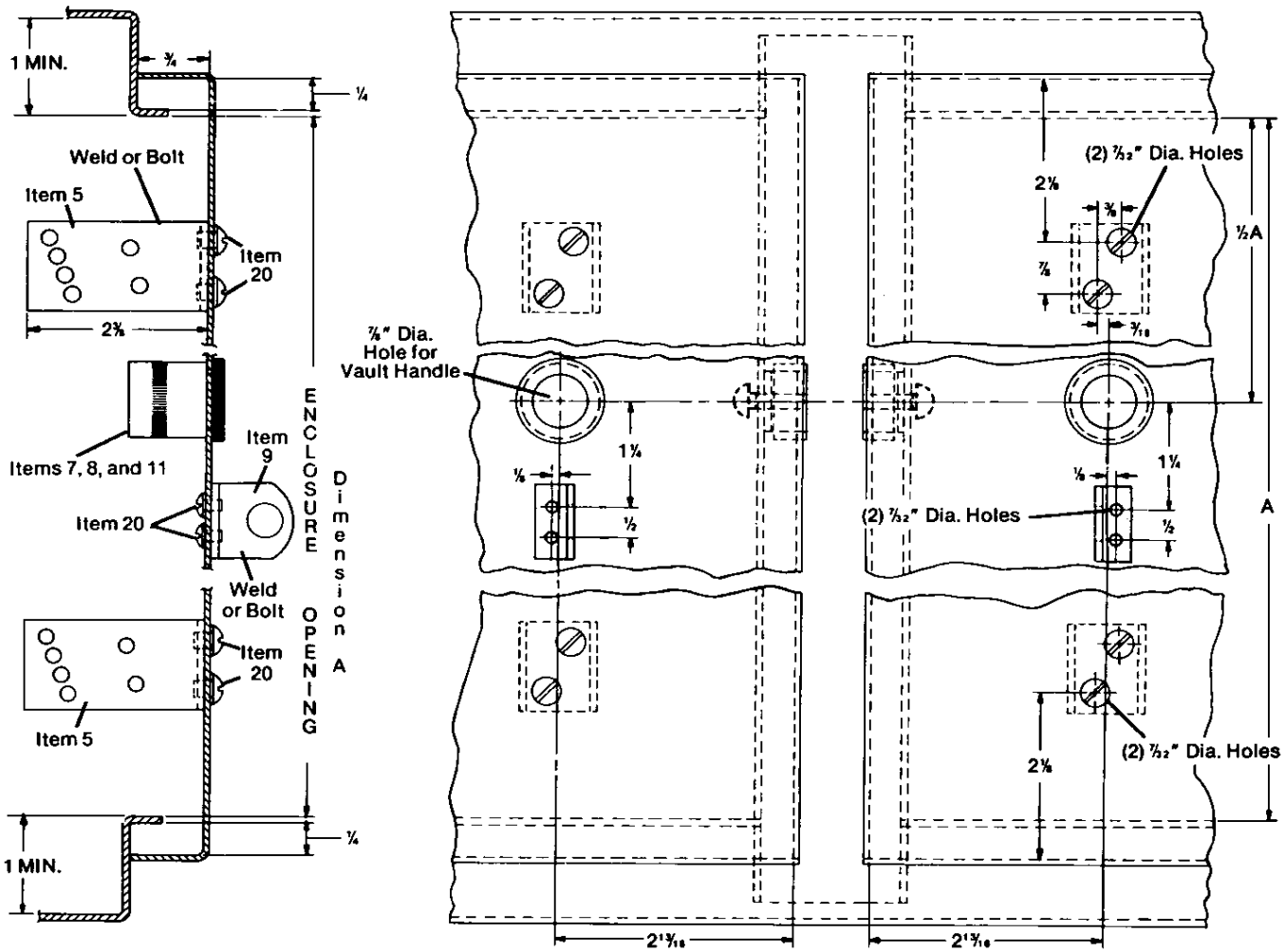

**Figure 1**  
**Enclosure Dimensions for Welded or Bolted Parts**

## INSTALLATION

Although bolted construction is illustrated, welding may be used if preferred. When bolted construction is used, deform the bolt ends for maximum security.

1. Locate all parts and drill all necessary holes. (See Figures 1, 2, 3A, 3B, 4, 5, and 6.)
2. Mount upper and lower guide brackets, Item 5, with (2) screw assemblies, Item 20.
3. Mount handle lock, Item 9, with (2) screw assemblies, Item 20, and mount roller bracket, Item 15, with (2) screw assemblies, Item 21.

**NOTE:** Enclosure with mounted parts should be painted at this time if necessary.

4. Attach bearing, Item 8, and gasket, Item 11, to door with ring nut, Item 7.
5. Insert handle, Item 10, into door and attach to the operating cam assembly, Item 12, with screw and washer, Items 13 and 14.
6. Insert pins, Item 6, through upper and lower guide brackets in the holes shown and lock with cotter pins, Item 3.
7. **LOCKING BARS:**  
The locking bar kit, Item 1, consists of (2) Class 9423 Type M660 locking bars. These bars must be cut to proper length in accordance with the directions below:
  1. Determine the enclosure opening "A" (see Figure 1).

2. Use the following formula to determine length "L" of each bar:

$$A/2 + 5/16 = L$$

3. Cut locking bars to determined length "L" and modify as shown.

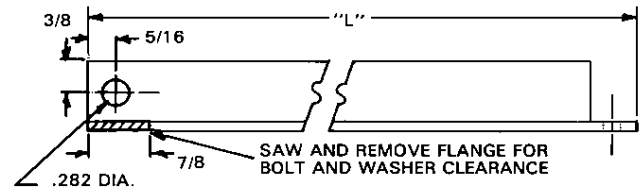

8. Slide the locking bars between the pins in the upper and lower guide brackets and attach the end of each bar to cam assembly, Item 12, with shoulder pin, washer, lockwasher, and nut, Items 16, 17, 18, and 19.
9. Attach rollers, Item 2, and pins, Item 4, to upper and lower locking bars, Item 1, and lock with cotterpins, Item 3.
10. Assemble (2) rollers, Item 2, and pin, Item 4, on roller bracket on enclosure and lock with cotter pin, Item 3.
11. Check assembly for proper operation. Door sealing can be adjusted by repositioning pins, Item 6.

## PARTS LIST

| ITEM | DESCRIPTION           | PART NO.     | QTY | ITEM | DESCRIPTION                  | PART NO.     | QTY |
|------|-----------------------|--------------|-----|------|------------------------------|--------------|-----|
| 1    | Locking Bar Kit       | 9423M660     | 1   | 12   | Operating Cam Assembly       | 30007-120-50 | 1   |
| 2    | Roller                | 3203-X3      | 6   | 13   | Screw 1/4-20 x 5/8           | 21401-20200  | 1   |
| 3    | Cotter Pin 5/64 x 1/2 | 24201-05160  | 7   | 14   | Washer 1/4                   | 23903-31601  | 1   |
| 4    | Pin                   | 3203-X5      | 3   | 15   | Roller Bracket               | 30007-129-01 | 1   |
| 5    | Guide Bracket         | 30007-095-01 | 2   | 16   | Shoulder Pin                 | 30007-124-01 | 2   |
| 6    | Pin                   | 294-D6-X12   | 4   | 17   | Washer #10                   | 23601-00160  | 2   |
| 7    | Ring Nut              | 30007-132-01 | 1   | 18   | Lock Washer #10              | 23701-00160  | 2   |
| 8    | Bearing               | 30007-122-01 | 1   | 19   | Nut #10-24                   | 23001-00160  | 2   |
| 9    | Handle Lock           | 30007-123-01 | 1   | 20   | Screw Assembly #10-24 x 5/16 | 21911-16100  | 6   |
| 10   | Handle                | 30007-118-51 | 1   | 21   | Screw Assembly #8-32 x 1/4   | 21911-14081  | 2   |
| 11   | Gasket                | 30007-133-01 | 1   |      |                              |              |     |

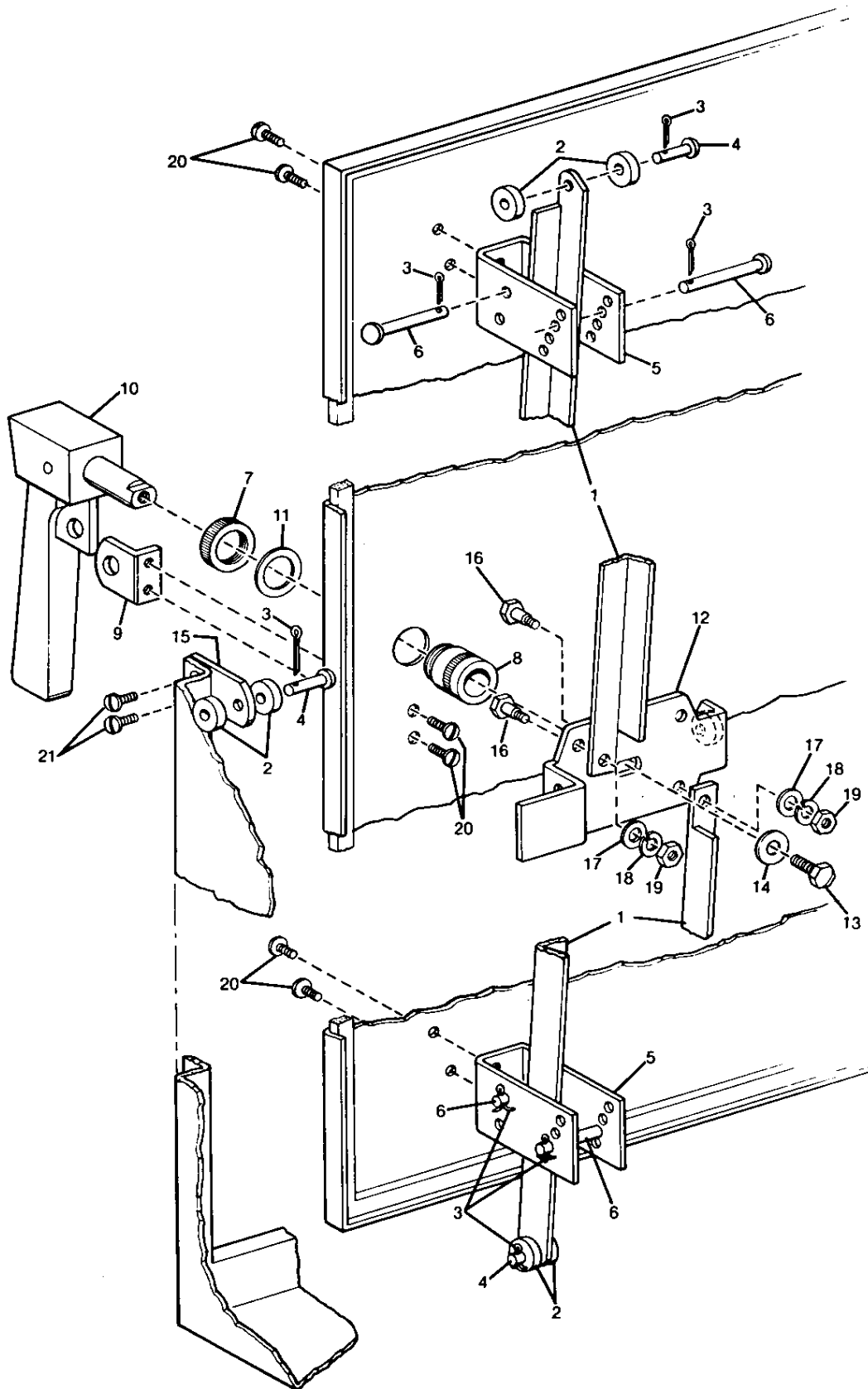
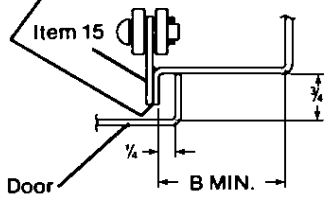

Figure 2

## ROLLER BRACKET LOCATION DETAILS

Locate at Vault Handle Center-line. See Figure 1 for typical installation.

Weld roller bracket flush with enclosure flange at  $\text{C}$  of Vault Handle.



**Figure 3A**  
For Door Closing  
on Enclosure Flange  
(Welded)

- B MIN. = 1 1/4" with Class 9422, type A1 Universal Operating Handle mounted on enclosure flange.
- B MIN. = 1/2" without Class 9422 Type A1 Universal Operating Handle.
- B MIN. = 2 1/4" with Class 9422, Type A1 Universal Operating Handle and Class 9423, Type M5 Mechanical Interlock.

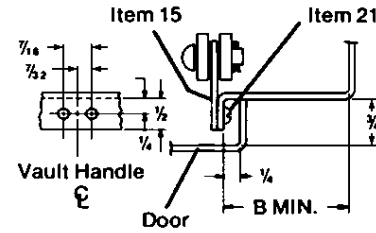

**Figure 3B**  
For Door Closing  
on Enclosure Flange  
(Bolted)

- C MIN. = 2 1/4" } without Class 9422 Type A1 Handle in channel.
- D MIN. = 1 1/4" } with or without Class 9423 Type M2 Auxiliary Interlock in channel.
- C MIN. = 3 1/4" } with Class 9422 Type A1 handle in channel.
- D MIN. = 2 1/4" }

Drill one #F (.257) hole in leg of inside door channel at  $\text{C}$  of Vault Handle.

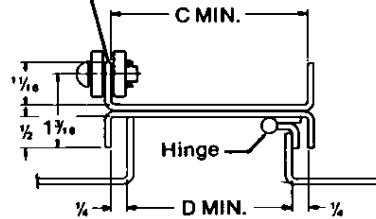

**Figure 4**  
For two doors: One Closing on a Channel and  
the other Hinged on the Same Channel

Drill one #F (.257) hole in each leg of inside door channel at  $\text{C}$  of Vault Handle.

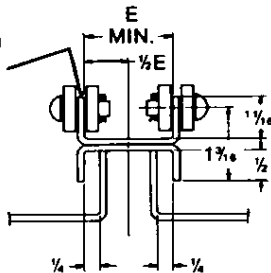

- E MIN. = 2" with Class 9422, Type M2 Interlock Kit.
- E MIN. = 1 1/2" without Class 9422, Type M2 Interlock Kit.

**Figure 5**  
For Two Auxiliary Doors Closing on a Common  
Channel With or Without  
Class 9423, Type M2 Interlock Kit

Drill one #F (.257) hole in each leg of inside door channel at  $\text{C}$  of Vault Handle.

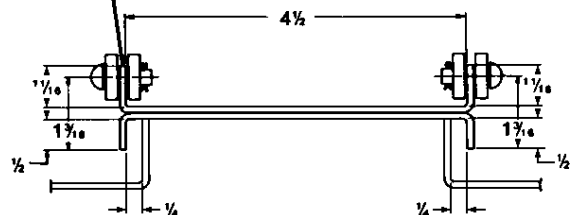

**Figure 6**  
For Two Doors Closing on a Common Channel  
with Class 9422, Type A1 Operating Handle,  
and Class 9423, Type M1 interlock and  
Type M2 Auxiliary Interlock



# California Proposition 65 Warning—Lead and Lead Compounds

## Advertencia de la Proposición 65 de California—Plomo y compuestos de plomo

### Avertissement concernant la Proposition 65 de Californie—Plomb et composés de plomb

**⚠ WARNING:** This product can expose you to chemicals including lead and lead compounds, which are known to the State of California to cause cancer and birth defects or other reproductive harm. For more information go to: [www.P65Warnings.ca.gov](http://www.P65Warnings.ca.gov).

**⚠ ADVERTENCIA:** Este producto puede exponerle a químicos incluyendo plomo y compuestos de plomo, que es (son) conocido(s) por el Estado de California como causante(s) de cáncer y defectos de nacimiento u otros daños reproductivos. Para mayor información, visite : [www.P65Warnings.ca.gov](http://www.P65Warnings.ca.gov).

**⚠ AVERTISSEMENT:** Ce produit peut vous exposer à des agents chimiques, y compris plomb et composés de plomb, identifiés par l'État de Californie comme pouvant causer le cancer et des malformations congénitales ou autres troubles de l'appareil reproducteur. Pour de plus amples informations, prière de consulter: [www.P65Warnings.ca.gov](http://www.P65Warnings.ca.gov).

All trademarks are the property of Schneider Electric SE, its subsidiaries, and affiliated companies.

**Schneider Electric USA, Inc.**  
800 Federal Street  
Andover, MA 01810 USA  
888-778-2733  
[www.schneider-electric.us](http://www.schneider-electric.us)

Todas las marcas comerciales son propiedad de Schneider Electric SE, sus filiales y compañías afiliadas.

Importado en México por:  
**Schneider Electric México, S.A. de C.V.**  
Av. Ejercito Nacional No. 904  
Col. Palmas, Polanco 11560 México, D.F.  
55-5804-5000  
[www.schneider-electric.com.mx](http://www.schneider-electric.com.mx)

Toutes les marques commerciales sont la propriété de Schneider Electric SE, ses filiales et compagnies affiliées.

**Schneider Electric Canada, Inc.**  
5985 McLaughlin Road  
Mississauga, ON L5R 1B8 Canada  
800-565-6699  
[www.schneider-electric.ca](http://www.schneider-electric.ca)