



## Main

Product	Single Throw Safety Switch
Current Rating	400 A
Number of Poles	3
Voltage Rating	600 V AC/DC
Disconnect Type	Non-fusible disconnect
Short Circuit Current Rating	200 kA maximum
Mounting Type	Surface
Factory Installed Neutral	None
Electrical Connection	Lugs
Duty Rating	Heavy duty
Certifications	UL listed file E2875
Enclosure Rating	NEMA 1 steel
Wire Size	AWG 1/0...750 kcmil copper or aluminium

## Complementary

Short-circuit withstand	200 kA
Maximum Horse Power Rating	125 Hp 240 V AC 50...60 Hz 3 phase NEC 430.52 250 Hp at 480 V AC 50...60 Hz for 3 phases motors conforming to NEC 430.52 350 Hp at 600 V AC 50...60 Hz for 3 phases motors conforming to NEC 430.52 50 Hp 250 V DC 50 hp 600 V DC
Tightening torque	62.14 N.m (AWG 1/0...750 kcmil)
Width	27.63 in (701.80 mm)
Height	50.25 in (1276.35 mm)
Maximum Depth	10.13 in (257.30 mm)

## Ordering and shipping details

Category	00053 - H&HU SW,NEMA1,400-1200A
Discount Schedule	DE1
GTIN	00785901787303
Nbr. of units in pkg.	1
Package weight(Lbs)	170 lb(US) (77.11 kg)
Returnability	Yes
Country of origin	MX

## Packing Units

Unit Type of Package 1	PCE
Package 1 Height	14.29 in (36.3 cm)
Package 1 width	28.31 in (71.9 cm)
Package 1 Length	52.01 in (132.1 cm)

## Offer Sustainability

Sustainable offer status	Green Premium product
California proposition 65	WARNING: This product can expose you to chemicals including: Lead and lead compounds, which is known to the State of California to cause cancer and birth defects or other reproductive harm. For more information go to <a href="http://www.P65Warnings.ca.gov">www.P65Warnings.ca.gov</a>
REACH Regulation	<a href="#">REACH Declaration</a>
REACH free of SVHC	Yes
EU RoHS Directive	Compliant <a href="#">EU RoHS Declaration</a>
Mercury free	Yes
RoHS exemption information	<a href="#">Yes</a>
China RoHS Regulation	<a href="#">China RoHS Declaration</a>
Environmental Disclosure	<a href="#">Product Environmental Profile</a>
PVC free	Yes
Halogen content performance	Halogen free plastic parts product

## Contractual warranty

Warranty	18 months
----------	-----------

Approximate Dimensions

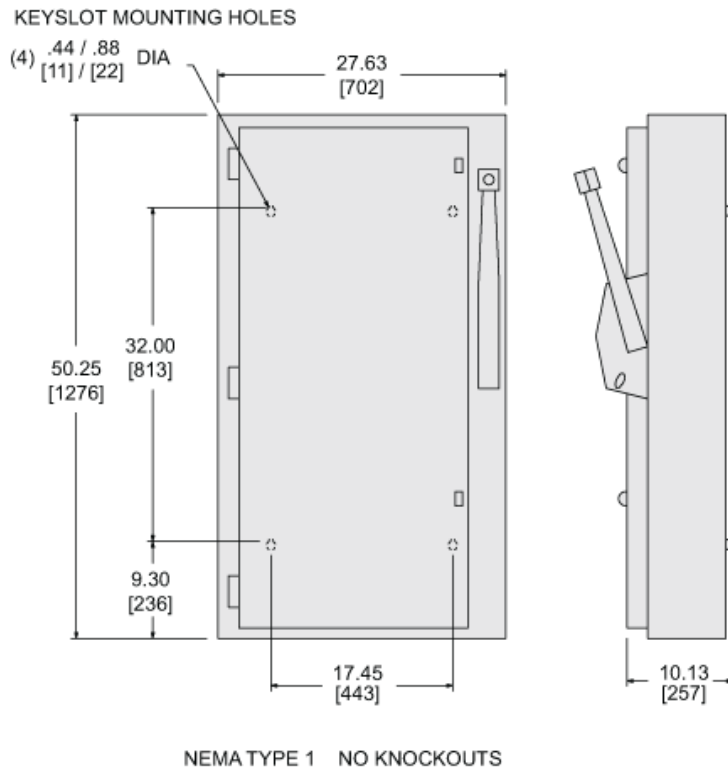

Wiring Diagrams

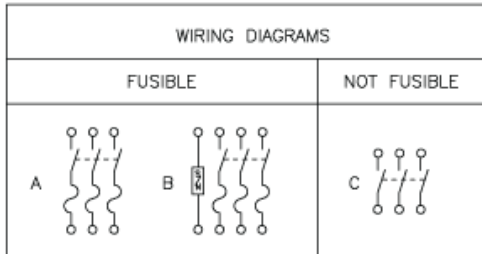

NOTE: FOR SWITCHING DC USE TWO OUTSIDE POLES.

TERMINAL LUGS DATA			
AMPERES	MAX WIRE	MIN WIRE	TYPE
400	(1) 750 KCMIL OR (2) 300 KCMIL	(1) #1/0 AWG OR (2) #1/0 AWG	AL OR CU

CATALOG NUMBER	MAX VOLTAGE RATINGS	WIRING DIAG	HORSEPOWER RATINGS							
			240VAC		480VAC		600VAC		250 VDC	600 VDC
			MAX	STD	MAX	STD	MAX	MAX	MAX	
H365	600VAC:600VDC	A	-	100	250	125	350	50	50	
H365N	600VAC:600VDC	B	-	100	250	125	350	50	50	
HU365	600VAC:600VDC	C	125	-	250	-	350	50	50	