

Instruction Bulletin

Replaces 478 AS dated 9/80

800 A Mechanically Held AC Magnetic Lighting Contactor Class 8903 Type SJ, Series A

Retain for future use.

INTRODUCTION

This bulletin contains installation, assembly, operation, maintenance, and parts ordering instructions. To identify parts (denoted by parentheses), refer to Table 1, Table 4 on page 4, and Figure 2 on page 5 unless otherwise noted.

⚠ DANGER

HAZARDOUS VOLTAGE

Disconnect all power before working on any equipment.

Failure to follow this instruction will result in death or serious injury.

INSTALLATION

When assembling the device, refer to Figure 2 on page 5.

Mounting

Mount the device on a vertical surface, with line terminals up. When mounting an open device, mount the device with three 1/2-inch bolts tightened to 500–550 lb-in.

Terminals

Use either copper or aluminum conductors on power terminals of standard contactors. Use the factory-recommended tightening torques listed in Table 1 when installing, assembling, or adjusting the device.

Table 1: Factory-Recommended Tightening Torques

Item	Description	Part No.	Quantity		Torque (lb-in)
			2 Pole	3 Pole	
A	Coil terminal pressure wire connector	31051-007-50	2	2	9–12
B	Cover screw	21926-20321	4	4	65–75
C	Shroud holding screw	21926-20522	2	2	65–75
D	Armature screw	21926-20521	2	2	44–50
E	Coil terminal pressure wire connector screw	21904-12101	2	2	9–12
F	Power plant screw	21926-20522	2	2	65–75
H	Magnet core screw	21511-14120	2	2	18–21
I	Electrical interlock pressure wire connector	31033-084-51	2	2	9–12
J	Terminal-to-standoff screw	21401-20360	4	6	65–75
K	Stationary contact screw	21401-28400	4	6	360–420
L	Power terminal lug screw Accommodates wire size 3/0 AWG – 750 MCM	[1]	12	18	500
Q	Lug retaining screw	21401-28662	4	6	[2]
R	Anti-rotation plate retaining screw (1/2"-13 x 1-1/2")	21401-28480	4	4	300–350

[1] Part of the assembly 25098-25110

[2] Tighten until the Belleville washer flattens.

Cover Mounted Control Units

The NEMA Type 1 general purpose enclosure contains three punched holes with closing plates for field addition of the Class 9001 Type K oiltight/watertight control units listed in Table 2.

Table 2: Field Modification Kits

Kit	Description	Class 9001 Type	Qty.
Push Button, On-Off	On operator	KR1U	1
	Off operator	KR1U	1
	On legend plate	KN203 [1]	1
	Off legend plate	KN204 [1]	1
	Contact block	KA1	2
Selector Switch, Hand-Off-Auto	Selector switch operator	KS43B	1
	Hand-off-auto legend plate	KN260 [1]	1
	Contact block	KA1	1
Selector Switch, On-Off	Selector switch operator	KS11B	1
	On-off legend plate	KN245 [1]	1
	Contact block	KA1	1
Red Pilot Light (120 V only)		Select correct Type KP unit from catalog	

[1] NEMA Type 4 enclosures use Type KN8 nameplates plus Type KU protective caps.

Electrical Interlocks and Timer Attachment

Normally open and normally closed interlocks can be installed in the field. A mechanically operated pneumatic timer is also available for field addition. Refer to the Class 9999 section of the Square D *Digest* for selection and application information.

OPERATION

Manual Operation

⚠ DANGER

HAZARDOUS VOLTAGE

Disconnect all power before manually operating the contactor.

Failure to follow this instruction will result in death or serious injury.

To manually latch the contactor, push on the armature screws (D).

To manually unlatch the contactor, push the unlatch armature (12) toward the unlatch coil (2), to its energized position and the actuator pin will release the latch mechanism. (Refer to Figure 1 on page 4.)

Short Circuit Protection

Provide branch circuit overcurrent protection for each contactor in accordance with the National Electrical Code.

Distant Control

Series impedance may limit the maximum distance of the wire run for remotely operated contactors. However, mechanically held devices are unaffected by shunt capacitance because the coils are always turned off at the contactor through the coil clearing contacts. Table 3 on page 3 shows the maximum control distance based on the size of copper wire used.

Table 3: Maximum Control Distance

Coil Voltage (V) at 60 Hz	Max. Control Distance (ft) for Copper Wire ^[1]		
	16 AWG	14 AWG	12 AWG
120	50	85	130
208	160	255	400
240	215	340	530
277	285	450	705
480	865	1365	2130

^[1] Based entirely on series impedance. It allows for a 5% voltage drop between the source and the coil.

MAINTENANCE

Inspecting and Replacing Contacts

Discoloration and slight pitting do not harm contacts. *Do not file contacts*; this wastes contact material. Replace contacts only when worn thin. Refer to Table 4 on page 4 for replacement kits.

To inspect or replace contacts, disconnect all power. Do not remove any wiring. Loosen the following screws, then lift the contact actuator to expose the contacts:

- the two screws (D) holding the armature to the movable contact carrier
- the four screws (C and F) holding the contact actuator to the contact block

When reassembling the contactor, ensure proper alignment of the contact actuator by tightening the four screws (C and F) as instructed below:

1. Face the contactor mounted in the normal vertical position.
2. Tighten the screws in this order: lower left, upper left, upper right, and lower right. Follow the tightening torques listed in Table 1 on page 1.

Manually operate the contactor after reassembly to ensure that all parts function properly (see “Manual Operation” on page 2).

Coil Replacement

CAUTION
COIL BURNOUT
Both coils are rated for intermittent energization only. Apply voltage to them only through the coil-clearing contacts, as shown in the wiring diagram affixed to the device.
Failure to follow this instruction can result in equipment damage.

To replace the latch coil (refer to Figure 2 on page 5):

1. Disconnect the wires from the coil terminals (A).
2. Loosen the four captive cover screws (B) and the two shroud-holding screws (C), then remove the cover.
3. Loosen the two screws (D) holding the armature in place.
4. Remove the latch coil and armature assembly.
5. Separate the coil from the armature assembly.
6. Replace the latch coil.
7. Reassemble in the reverse order.

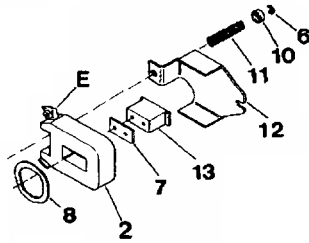

Figure 1: Unlatch Coil Assembly

To replace the unlatch coil (refer to Figure 1 and to Figure 2 on page 5):

1. Disconnect the wires from the coil terminals (E).
2. Remove the guide pin (9) by first removing the E-ring (6), the cup washer (10), and the spring (11).
3. Remove the two magnet-core retaining screws (H).
4. Slide the armature (12), the core (13), the shim (7), the unlatch coil (2), and the washer (8) toward the left, disengaging the assembly from the actuator pin.

NOTE: Place the washer (8) and the shim (7) into their proper positions before inserting the replacement coil.

5. Replace the unlatch coil.
6. Reassemble in the reverse order.

ORDERING INSTRUCTIONS

Specify the quantity, the part number or Class and Type, and the description of the part, giving the complete nameplate data of the device (for example, one latch coil clearing contact, Class 9001 Type KA3 for a Class 8903 Type SJO11, Series A mechanically held lighting contactor).

Table 4: Parts List

Item	Description	Part Number	Quantity	
			2 Pole	3 Pole
1	Latch coil	See Table 5	1	1
2	Unlatch coil	See Table 5	1	1
3	Contact kit	Class 9998 Type SL30	1	—
		Class 9998 Type SL31	—	1
4	Latch coil clearing contact	Class 9001 Type KA3	1	1
5	Unlatch coil clearing contact	Class 9999 Type SX6	1	1
6	E-ring	29907-01010	1	1
H	Magnet core fasteners: Screw #8-32 x 3/8" Washer #8	21511-14120	2	2
		23701-00140	2	2
7	Magnet core shim	31074-147-01	1	1
8	Washer	23903-26601	1	1
14	Lug assembly	25098-25110	4	6
15	Anti-rotation plate	31123-032-01	4	4
Q	Lug retaining screw 1/2"-13 x 2-1/4"	21401-28662	4	6
R	Screw 1/2"-13 x 1-1/2	21401-28480	4	4

The complete part number of the coil consists of the coil prefix followed by the frequency-voltage suffix (e.g., for a 120 V, 60 Hz latch coil, select part number 31104-418-09). When ordering replacement coils, give the part number, voltage, and frequency of the coil being replaced.

Table 5: Magnet Coils

Coil	Coil Prefix	Frequency (Hz)	110 V	120 V	208 V	220 V	240 V	277 V	440 V	480 V	550 V	600 V
Latch	31104-418	60	—	09	15	—	18	19	—	24	—	29
		50	09	—	—	18	—	—	24	—	29	—
Unlatch	31104-403	60	—	09	15	—	18	20	—	24	—	28
		50	09	—	—	18	—	—	24	—	28	—

ASSEMBLY DRAWING

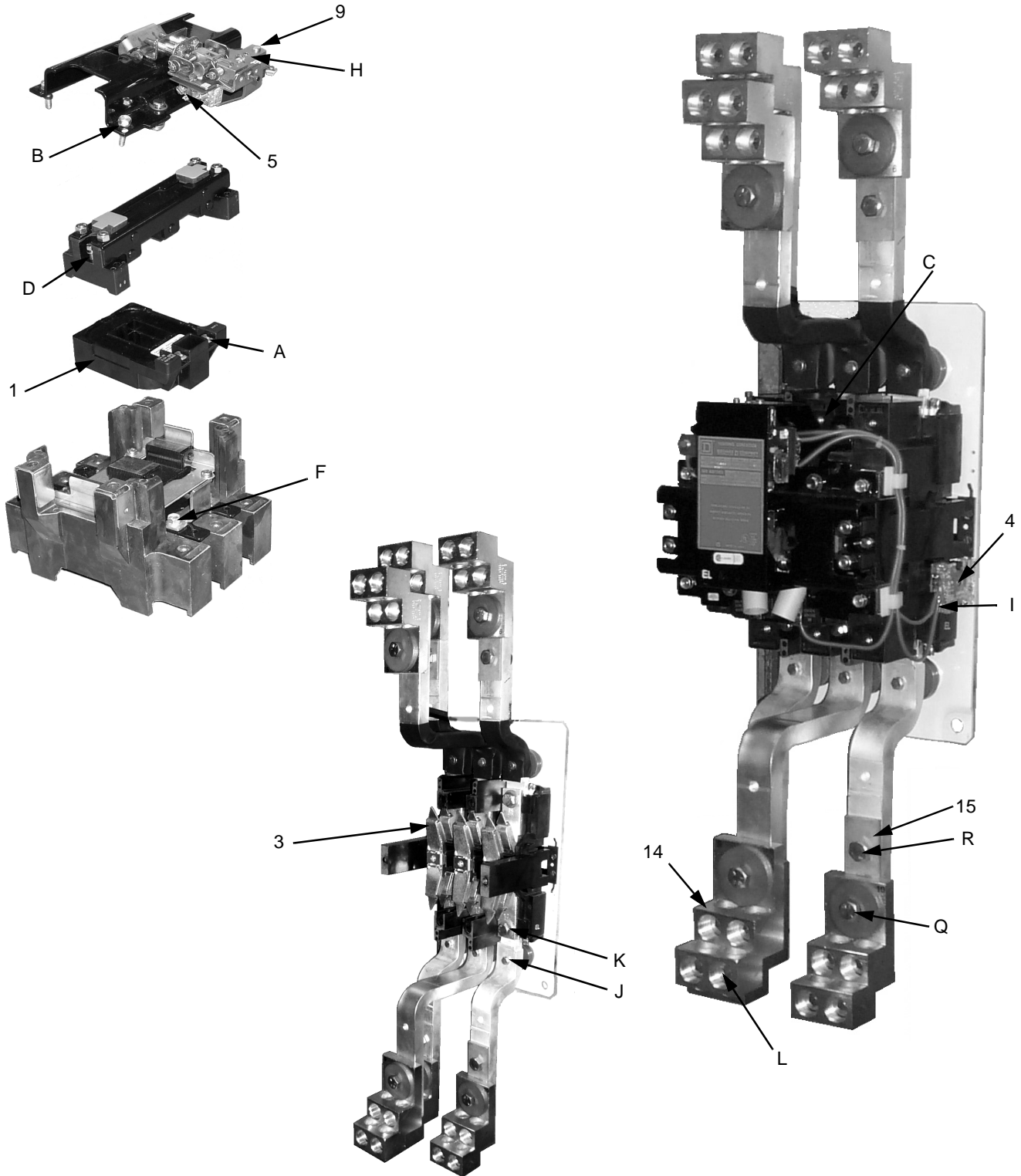

Figure 2: Contactor Assembly Drawing

Square D Company
8001 Highway 64 East
Knightdale, NC 27545
1-888-SquareD (1-888-778-2733)
www.SquareD.com

Electrical equipment should be serviced only by qualified personnel. No responsibility is assumed by Schneider Electric for any consequences arising out of the use of this material. This document is not intended as an instruction manual for untrained persons.

