

NOTES:

1. DIMENSIONS SUBJECT TO +/- 3% TOLERANCE
2. LEAKAGE DISTANCE (Inches) - 15.4
3. ALTITUDE 0-12000 FT. ABOVE SEA LEVEL
4. WEIGHT OF UNIT INCLUDING HARDWARE - 6.1 LB.
5. MAXIMUM CONTINUOUS LINE-TO-GROUND OPERATING VOLTAGE 8.4 KV MCOV
6. DUTY CYCLE VOLTAGE RATING 10 KV RMS.

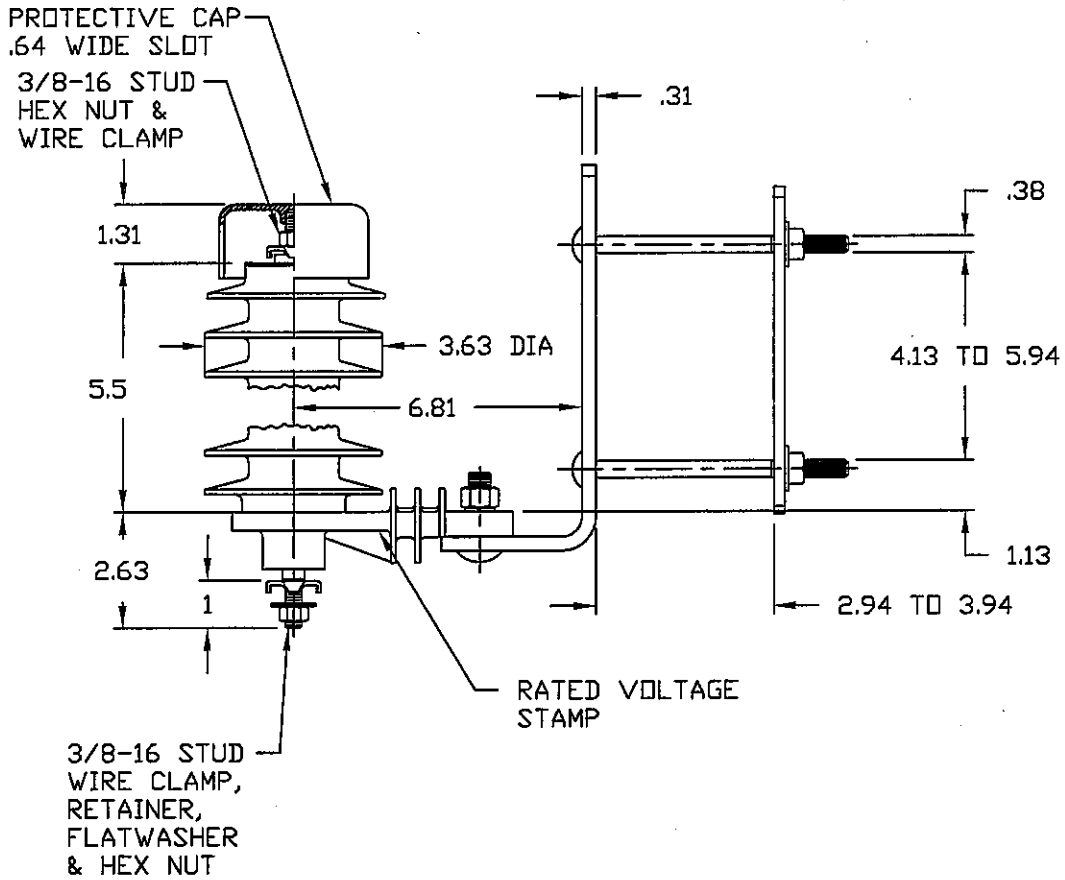

.5μ SEC 5kA IR KV	500 A SWITCHING SURGE IR KV	MAXIMUM 8/20 DISCHARGE VOLTAGE - KV AT					
		1.5 kA	3.0 kA	5 kA	10 kA	20 kA	40 kA
36.0	24.0	27.0	29.5	31.5	36.0	41.5	53.0

DISTRIBUTION CLASS SURGE ARRESTER				
	CONFIDENTIAL: THIS DRAWING AND ITS CONTENTS ARE CONFIDENTIAL AND THE EXCLUSIVE PROPERTY OF HUBBELL POWER SYSTEMS. NO PUBLICATION, DISTRIBUTION OR COPIES MAY BE MADE WITHOUT THE WRITTEN CONSENT OF HUBBELL POWER SYSTEMS. HUBBELL POWER SYSTEMS UNPUBLISHED. ALL RIGHTS RESERVED UNDER THE COPYRIGHT LAWS.	TITLE PDV-65 ARRESTER 8.4 KV MCOV		
		SIZE S	DWG NO. ALES7XXX	CAT / PART / ASSY NO. 217259-7324
REV DATE 10/24/07	DO NOT SCALE THIS DRAWING	DRN BY ENG109	DATE 06/17/00	SHEET 1 OF 1