

SCREW: SEE CHART	MATERIAL: ALUMINUM	REV: F	 800-776-9775 www.ilSCO.com
CAT. NO.: SEE DWG	PLATING: EL-TIN/WAX	DRAWN BY: CLH SCALE: 1:1	
INFORMATION SHEET: SEE CHART	MARKING: 1000kcmil-2, AL-CU	DATE: 5/11/2007 SIZE: B	
			DWG NO: D3867
			SHEET: 1 OF 1

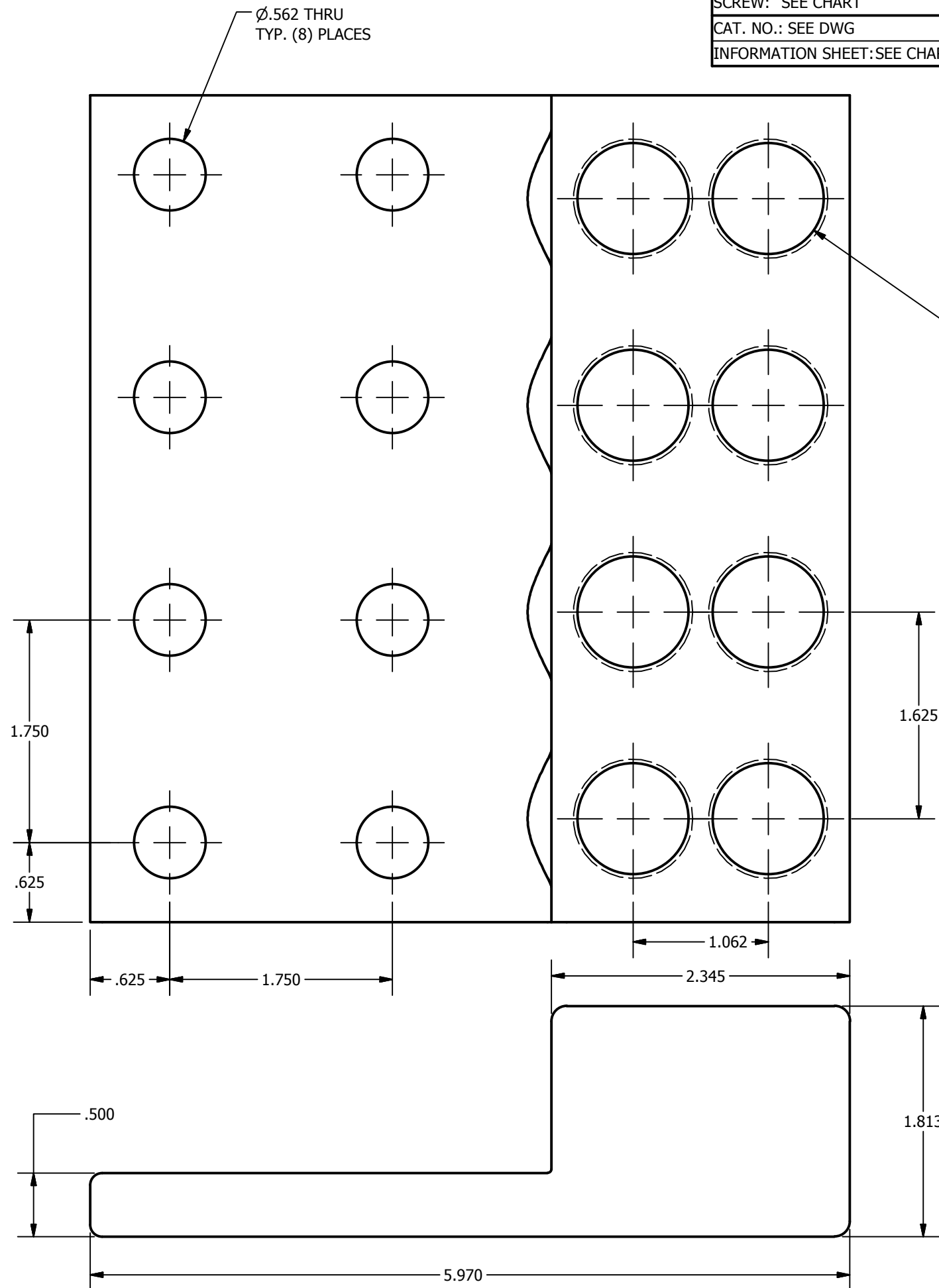

15/16-16 UN - 2B
(8) PLACES

SEE CHART FOR SCREW
FLUSH TO TOP
(8) PLACES

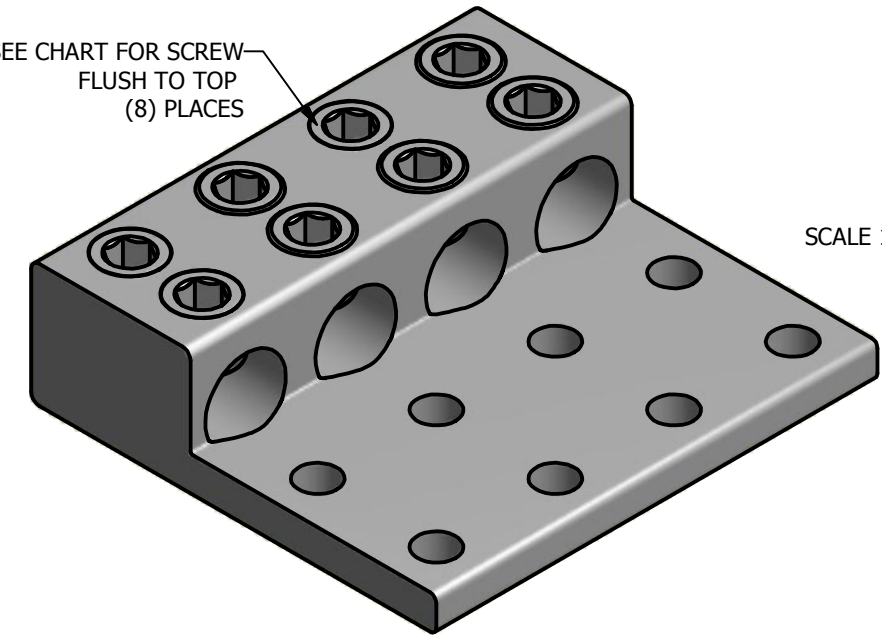

SCALE 1 / 2

CATALOG NO.	FORM	MARKING	PLATING	SCREW
T4A4-1000N	FORM 1	ILSCO, T4A4-1000N, 1000-350kcmil, AL9CU 	EL-TIN	E0945
USG2-1000R84	FORM 18	UTILCO, USG2-1000R84, 1000-350kcmil, AL-CU	WAX	E6134
USG2-1000R84LS	FORM 18	UTILCO, USGS-1000R84LS, 1000kcmil-2, AL-CU	WAX	E0686

