

# thermOweld<sup>®</sup>

## Cathodic Protection Catalog



The Contractors Choice

1-800-558-1373 or FAX 1-800-788-1668 • Visit [www.conind.com](http://www.conind.com)



## The thermOweld® Process

The thermOweld® permanent-connection process has been engineered to be an easy and efficient field welding system. No outside power, bulky gas tanks or other equipment associated with welding are required with the thermOweld® system. Any field installer or contractor can use our high-grade graphite molds designed and produced in thermOweld's world-class volume CNC manufacturing operations.

**Incorporating our patented EZ Lite® mold lid (see page 10), ignition is done safely from the top of the mold with limited exhaust emanating from the side vent.** This innovation from thermOweld®, combined with other unique features, make even tight field installations possible. For indoor connections where desired, thermOweld® offers low-emissions molds as well. Contractors worldwide demand thermOweld® for ease of use and the safest operation.

Using thermOweld's superior weld metal (see page 90), a high-temperature reaction between special formulations of copper oxide and aluminum occurs in the mold crucible. Upon reaching critical temperature, the resulting molten copper drops into the weld cavity, instantly creating a high-temperature molecular bond with the conductor. This weld connection cools rapidly and the mold can be removed for the next connection with thermOweld's special off-set handle clamps (page 94). The thermOweld® process creates a superior connection without the excessive applied heat of brazing, arc welding or soldering. This is important especially for welding insulated cables or to thin-wall pipe.

The thermOweld® process creates a permanent, homogenous and molecular bond that cannot loosen or corrode. Compared to compression connectors, split bolts, crimp connectors, brazing and other connections, the thermOweld® connection is clearly superior. In fact, a thermOweld® connection will also withstand more current than the conductor itself.

### It's easy to see why thermOweld® is The Contractor's Choice worldwide!

The thermOweld® process has been used to weld materials other than copper for electrical purposes, including:

Stainless Steel	Galvanized Steel*	Columbium	Kama	Brass	Chromax
Copperweld®	Silicon Bronze	Plain Steel	Steel Rail	Bronze	Cast Iron
Nichrome V	Copper-Clad Steel	Everdur®	Cor-Ten®	Niobium	Monel

\*When welding to galvanized steel it is recommended to resurface exposed bare steel.

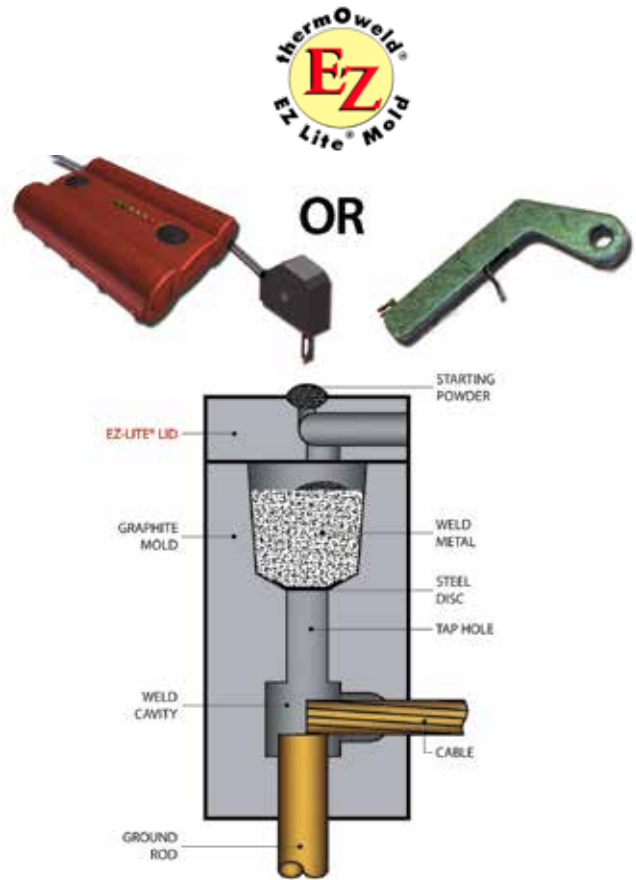

## Standards Relating to thermOweld Designs of Earthing, Grounding and Lightning Protection

Standards	Country	Description
IEEE: 80-1986	USA, Australia, Asia, Europe, Latin America	Guide for Safety in AC Substation Grounding
IEEE: 837-2002	USA, Australia, Asia, Latin America	Standard for Qualifying Permanent Connections used in Substation Grounding
IEEE: 81-1983	USA, Australia, Asia	Guide for Measuring Earth Resistivity, Ground Impedance and Earth Surface Potential of a Ground System
IEEE: 998-1996	USA, Australia, Asia	Guide for Direct Lightning Strike Shielding of Substations
UL 467	USA, Australia, Asia	Grounding and Bonding Equipment
NFPA 780	USA, Australia, Asia	Lightning Protection
IEC/TS 60479-1	Europe, Brazil	Effects of Current passing through human beings & livestock
EN62305-3: 2011	Europe	Protection against Lightning, Physical damage to structure and life hazard
ANCE NMX-J-549-2005	Latin America	Lightning Protection

## WHY IS GOOD GROUNDING IMPORTANT?

Good grounding (earthing) starts with a robust, durable, low-resistance connection between the earth and electrical equipment or electrical circuit ground. This necessary low-resistance connection insures the proper ground path for personnel safety and the proper functioning of electrical and electronic devices. Whether to present a good reference ground, direct a faulty circuit's potential to ground, or to dissipate an electrical surge or lightning strike, a uniform ground with the earth is essential in today's infrastructure.

Many factors, including soil resistivity, installation accessibility, layout and surrounding physical features must be taken into consideration when establishing a superior grounding system. On this page we highlight some key areas to consider in your grounding system and remind you that all electrical systems must be built in accordance with applicable codes and standards for your area.

## GROUNDING PRINCIPLES

Low impedance is the key. All grounding connections should be as short and direct as possible to minimize inductance and reduce peak voltages induced in the connections. The ground electrode system must efficiently couple the ground by maximizing capacitive coupling to the soil. The resistance of the ground itself must also be minimized.

## GROUND IMPEDANCE

Soil resistivity is an important design consideration. It varies markedly for different soil types, moisture content and temperatures and gives rise to variations in ground impedances.

## SHORT, DIRECT GROUND CONNECTIONS

The voltage generated, especially by a lightning surge depends primarily on the rise time of the surge current and the impedance (primarily inductance of the path to ground). Extremely fast rise times result in significant voltage rises due to any series inductance resulting from long, indirect paths, or sharp bends in the routing of ground conductors.

## COUPLING FROM THE ELECTRODE SYSTEM TO THE GROUND

The efficiency of a ground electrode system is dependent on a number of factors, including the geometry of the ground electrode system, the shape of the conductors and the effective coupling into the soil.

## CHARACTERISTICS OF A GOOD GROUNDING SYSTEM

- Good electrical conductivity
- Conductors capable of withstanding high fault currents
- Long life - at least 40 years
- Low ground resistance and impedance

The basic philosophy of any grounding installation should be an attempt to maximize the surface area of electrodes or conductors with the surrounding soil. Not only does this help to lower the earth resistance of the grounding system, but it also greatly improves the impedance of the grounding system under lightning surge conditions.

- Equipotential bonding

Equipotential bonding helps ensure that hazardous potential differences do not occur between different incoming conductors such as metallic water services, power systems, telecommunications systems and the local ground, and also minimizes step and touch potentials.

- Good corrosion resistance

The ground electrode system should be corrosion resistant, and compatible with other conductors that are buried and bonded to the ground system. Copper is by far the most common material used for grounding conductors. In general, some form of maintenance or inspection procedure should be adopted to ensure the long-term effectiveness of a grounding system.

- Electrically and mechanically robust and reliable

Mechanical coupling can be used to join ground conductors, but suffers from corrosion effects when dissimilar metals are involved. As well as mechanical strength, thermOweld® connections provide excellent low impedance, long life electrical connections with excellent corrosion resistance.

## thermOweld® EXOTHERMIC MOLDS

thermOweld® is a process of welding copper to copper, copper to steel and copper to ductile iron. The exothermic reaction takes place in a semi-permanent graphite mold with a special formula of copper oxide and aluminum.

thermOweld® connections are solid copper molecular bonds that do not loosen or corrode throughout the life of the host structure. These bonds are the superior connection method for the most reliable and highest longevity of grounding, lightning protection, cathodic protection and other critical infrastructure systems.

**Standard Molds** – thermOweld® standard molds are given in the tables on the pages in this catalog and are used with new clean AWG and Metric wire and cable. A standard mold is not for use in “heavy-duty” applications; see Heavy Duty Molds.

**Heavy Duty Molds** – thermOweld® heavy-duty molds are given in the tables on the pages in this catalog (with an H suffix) and are employed for use with reused or reclaimed and heavily oxidized AWG and Metric wire and cable. In these cases a “heavy-duty” mold is recommended as it accepts this larger wire diameter and utilizes a larger weld metal cartridge size. The resulting connection is larger than a standard mold connection. Note that the grounding engineer may determine that the calculated theoretical ground fault current level may be abnormally high and therefore would prefer the larger mass of a heavy-duty mold connection.

thermOweld® has designed and produced over 15,000 unique molds to meet application needs worldwide. We have solved many applications with unique and customized molds, utilizing our CAD engineering and specialized CNC machining capabilities. If you don't see what you need in this comprehensive catalog, contact us. We are ready to support you quickly!

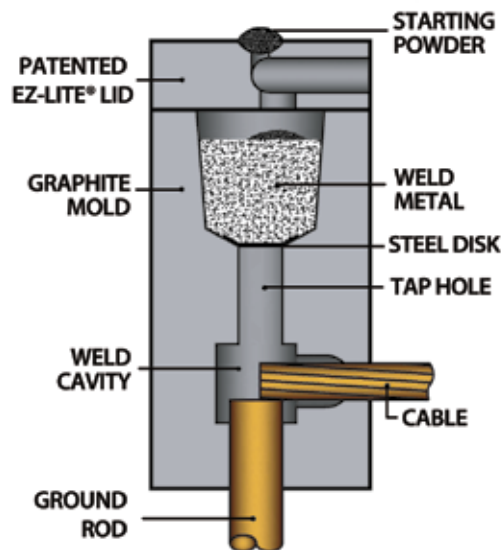

## SUPERIOR WELD METAL

thermOweld® weld metal is packaged in moisture resistant plastic cartridges that have tight fitting caps. These cartridges and the necessary steel discs are then packaged in boxes that are shrink wrapped. Shrink wrapping ensures the weld metal will arrive in good condition, always dry, and ready for a positive ignition every time.

All weld metal is eligible for thermOweld's SDS (Same Day Service) shipment. Our SDS program is just like having it on your shelf.



## CATHODIC PROTECTION PRODUCTS, INCLUDING Ci thermOcap® & Ci thermOcap® PC

thermOweld®'s patented Ci thermOcap® is designed to cover your exothermically welded connections. The Ci thermOcap® features an elongated wire inlet which allows the cap to conform easier to the wire. The outer shell is also designed to prevent crushing during back fill. This product is sold in packs of 20 and is immediately available.

thermOweld®'s new Ci thermOcap® PC is designed to cover your exothermically welded connections. The Ci thermOcap® PC is our preprimed cap and requires no spray primer. You simply "Peel and Stick"!



## The Molecular Bond

The thermOweld® connection is a molecular weld. The weld has the same melting point as copper. This factor, along with the increased cross sectional area of the connection and insure the following:

- thermOweld® connections are not affected by a high current surge. Tests have shown that the electrical conductor will melt before the thermOweld® connection, when subjected to high short circuit current. Consult IEEE Standard 837.
- thermOweld® connections will not loosen or corrode at the point of weld. There are no contact surfaces or mechanical pressures involved.
- thermOweld® connections have a current-carrying capacity equal to or greater than that of the conductors.

## The EZ Lite® Mold

- Makes all thermOweld® molds EZ to ignite.
- Lights from the top at any angle.
- Reduces emissions by 50% or more.
- Reduces splatter.
- Keeps the handle clamps clean and prolongs life.
- Added Safety - The EZ Lite® Lid points the exhaust away from the user.



## Why Cathodic Protection?

Cathodic protection (CP) is a technique used to control the corrosion of a metal surface by making it work as a cathode of an electrochemical cell. This is achieved by placing in contact with the metal to be protected, another more easily corroded metal to act as the anode of the electrochemical cell. Cathodic Protection systems are most commonly used to protect steel, water/fuel pipelines and storage tanks; steel pier piles, ships, offshore oil platforms and onshore oil well casings.



**1**  
Clean pipe before making weld.



**2**  
Position conductor and mold onto pipe.



**3**  
Place metal disc in bottom of mold.



**4**  
Pour weld metal into mold.



**5**  
Close lid and place starting powder on top. Ignite starting powder with Flint Ignitor.



**6**  
Remove and clean mold before making next connection.

**thermOcap®**



Finish your connection with a Ci thermOcap®. page 18

Visit [www.thermOweld.com](http://www.thermOweld.com) for training videos

## INSTALLATION IS EASY!

### Making a thermOweld® Connection using the EZ Lite Remote® Electric Start System



1  
Position cleaned conductors in mold.



2  
Place metal disc in bottom of mold crucible.



3  
Pour powder into crucible.



4  
Insert the EZ Lite® Ignitor in the connector.



5  
Insert the EZ Lite® Ignitor in the top opening of the EZ Lite® Lid.



6  
Turn the power button to the "ON" position.



7  
Press the "Operate" button until the exothermic reaction is initiated.



8  
Remove weld and clean mold before making next connection.

thermOweld's EZ Lite Remote® is the latest technological advance for thermOweld® exothermic products and the entire industry! For over 50 years, thermOweld® has been developing and inventing products and practical solutions that have become "The Contractor's Choice" worldwide.

With our patent-pending EZ Lite Remote®, the contractor, installer and distributor has versatility and ease-of-use in hand.

You can use your existing thermOweld® EZ Lite® molds and weld metal that you already have in your truck, the jobsite or on your shelf!

Visit [www.thermOweld.com](http://www.thermOweld.com) for training videos

# TECHNICAL INFORMATION

## CONDUCTOR IDENTIFICATION

Bare Class A, B, and C, Concentric Conductor  
Based on ASTM Standard Specifications

Size AWG	Size in Circular Mils	Conductor Diameter	Number of wires				
			7	19	37	61	91
1000	1,000,000	1.152"			.1644*	.1280	.1048
800	800,000	1.031"			.1470*	.1145	.0938
750	750,000	.998"			.1424*	.1109	.0908
700	700,000	.964"			.1375*	.1071	.0877
600	600,000	.893"			.1273	.0992	.0812
500	500,000	.813"		.1622*	.1162	.0905	
400	400,000	.728"		.1451	.1040	.0810	
350	350,000	.681"		.1357	.0973	.0757	
300	300,000	.630"		.1257	.0900	.0701	
250	250,000	.575"		.1147	.0822	.0640	
4/0	211,600	.528"	.1739	.1055	.0756		
3/0	167,800	.470"	.1548	.0940	.0763		
2/0	133,100	.419"	.1379	.0837	.0600		
1/0	105,500	.373"	.1228	.0745	.0534		
1	83,690	.332"	.1093	.0664	.0467		
2	66,370	.292"	.0974	.0591			
3	52,630	.260"	.0867	.0526			
4	41,740	.232"	.0772	.0469			
6	26,240	.184"	.0612	.0372			
8	16,510	.146"	.0486	.0295			
10	10,380	.116"	.0385	.0234			
12	6,530	.0915"	.0305	.0185			
14	4,110	.0726"	.0242	.0147			

\*Class AA

## BARE SOLID COPPER WIRE

Based on ASTM  
Standard Specifications

Size AWG	Size in Circular Mils	Conductor Diameter
4/0	211,600	.4600"
3/0	167,800	.4096"
2/0	133,100	.3648"
1/0	105,500	.3249"
1	83,690	.2893"
2	66,370	.2576"
3	52,630	.2294"
4	41,740	.2043"
6	26,240	.1620"
8	16,510	.1285"
10	10,380	.1019"
12	6,530	.0808"
14	4,110	.0641"

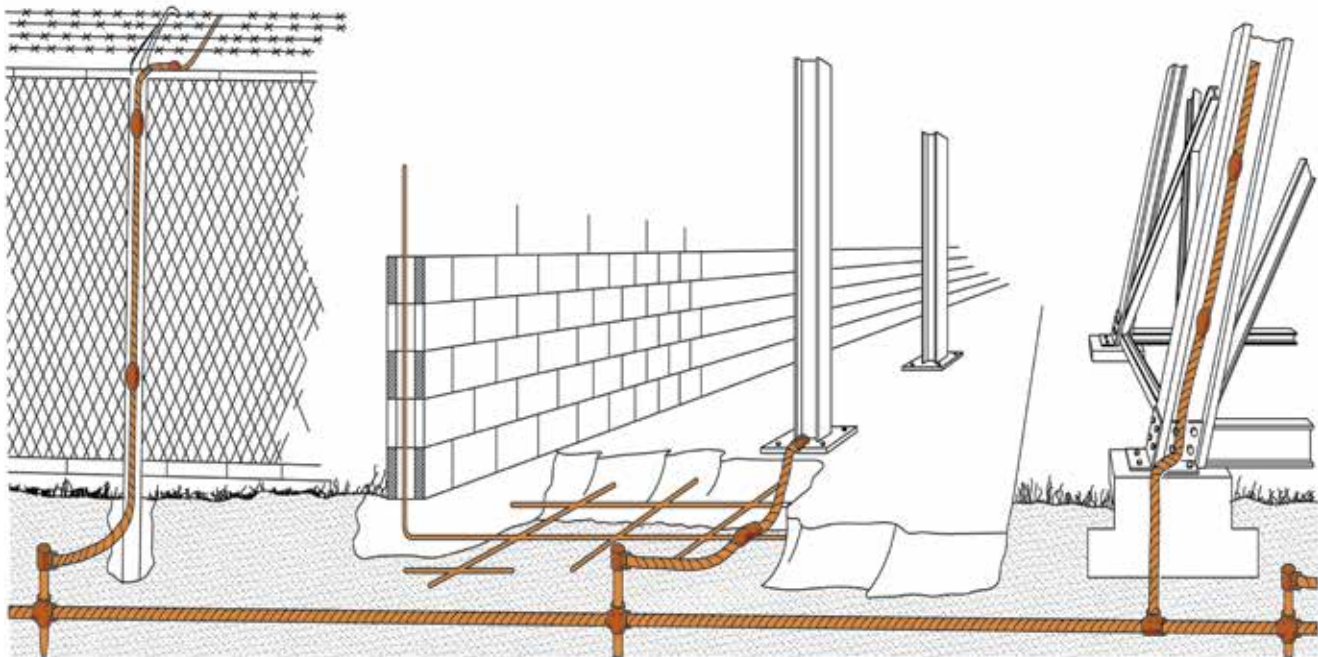

Some typical applications of thermOweld® connections in use.



## GROUND RODS

Size	Material	Type	Body Diameter	Thread Size
1/2"	Copperclad	Sectional	.505"	9/16"
	Copperclad	Plain	.475"	
	Steel*	Plain	.500"	
5/8"	Copperclad	Sectional	.563"	5/8"
	Copperclad	Plain	.563"	
	Steel*	Plain	.625"	
3/4"	Copperclad	Sectional	.682"	3/4"
	Copperclad	Plain	.682"	
	Steel*	Plain	.750"	
1"	Copperclad	Sectional	.914"	1"
	Copperclad	Plain	.914"	
	Steel*	Plain	1.00"	

\* Plain Steel, Stainless Steel, Stainless Clad Rods or Galvanized Steel

## STEEL PIPE SIZES

Standard Weight (Schedule 40)		ASTM A53-92-B ANSI/ASME B36.10M-1985
Nominal Size Inches	O.D. Inches	Wall Thickness Inches
1"	1.315	.133
1 1/4"	1.660	.140
1 1/2"	1.900	.145
2"	2.375	.154
2 1/2"	2.875	.203
3"	3.500	.216
3 1/2"	4.000	.226
4"	4.500	.237
5"	5.563	.258
6"	6.625	.280
8"	8.625	.322
10"	10.750	.365

## CONCRETE REINFORCING BARS US Imperial Sizes (Nominal Dimensions)

Rebar Sizes	Dia. Inches	Area - Sq. Inches
3	.375	.11
4	.500	.20
5	.625	.31
6	.750	.44
7	.875	.60
8	1.000	.79
9	1.128	1.00
10	1.270	1.27
11	1.410	1.56
14	1.693	2.25
18	2.257	4.00

## COPPER-CLAD STEEL CONDUCTORS

Cable Stranding	Conductor Diameter	Size in Circular Mils
3/#10 CW	.220"	31,150
3/#9 CW	.247"	38,280
3/#8 CW	.277"	49,530
7/#10 CW	.306"	72,680
3/#7 CW	.311"	78,750
7/#9 CW	.343"	91,650
3/#6 CW	.349"	99,310
7/#8 CW	.385"	115,600
3/#5 CW	.392"	99,310
7/#7 CW	.433"	145,700
7/#6 CW	.486"	183,800
7/#5 CW	.546"	231,700
19/#9 CW	.572"	248,800
7/#4 CW	.613"	292,200
19/#8 CW	.642"	313,700
19/#7 CW	.721"	395,500
37/#9 CW	.801"	484,400
19/#6 CW	.810"	498,800
37/#8 CW	.899"	610,900
19/#5 CW	.910"	628,900
37/#7 CW	1.010"	770,300

## RECTANGULAR COPPER BUSBAR

Thickness Inches	Width Inches	Circular Mil Size	Weight Lbs. Per Foot
1/8"	1"	159,200	.484
	1 1/2"	238,700	.726
	2"	318,300	.969
3/16"	1"	238,700	.727
	2"	477,500	1.45
1/4"	1"	318,300	.969
	1 1/2"	477,500	1.45
	2"	636,600	1.94
	3"	954,900	2.91
3/8"	4"	1,273,000	3.88
	1"	477,500	1.45
	1 1/2"	716,200	2.18
	2"	954,900	2.91
1/2"	3"	1,432,000	4.36
	4"	1,910,000	5.81
	2"	1,273,000	3.88
1/2"	3"	1,910,000	5.81
	4"	2,546,000	7.75

## Useful Conversions

### AREA

Sq.Inches x 1273 = kcmil  
Sq.Millimeteres x 1.974 = kcmil  
kcmil x .5067 = Square Millimeters

### DENSITY

Copper:  
.323 lb/in<sup>3</sup>  
Steel:  
.283 lb/in<sup>3</sup>

## How to Order thermOweld® Molds

The most common **exothermic connections** for concentric and solid copper conductors are listed in this thermOweld® catalog. Save Time and Money by using molds listed in this catalog. If you cannot find the necessary connection please contact thermOweld® at 1-800-558-1373 or visit our web site at [www.thermoweld.com](http://www.thermoweld.com) and go to the **Mold Selection Wizard** for assistance.

### 1. Determine the Weld Type required:

- a. Know the application to determine what materials are to be welded.
- b. Refer to Selector Chart for correct weld type on pages 20-30.
- c. Find the appropriate Weld Type in the catalog.

*There are pictures of each weld type in the upper corners of the catalog pages for easy reference*

### 2. Determine the Correct Mold #:

- a. Determine the Conductor Size or Sizes, Ground Rod Size or surface to be welded.
- b. Locate each of the above to find the correct Mold #.

*The thermOweld® catalog lists molds that are designed for stranded AWG concentric and solid cable, as well as ground rods, bus bar, lugs, steel, rebar, and other special grounding accessories. For sizes not listed please contact thermOweld® at 1-800-558-1373.*

### 3. After Determining the Correct Mold # Verify the Following:

- a. Price Key - Find the price of the mold by crossing it on the thermOweld® price lists.
- b. Weld Metal (size) needed to make weld.
- c. Handle Clamps required for the mold.
- d. Packing Materials (if needed).
- e. See Notes - for other accessories needed or suggested to make this connection.

### Please Check to make sure you have the following to make a proper weld:

- 1) Mold that fits your application.
- 2) Weld Metal required for the connection.
- 3) Handle Clamps or frame.
- 4) Flint Ignitor or EZ Lite Remote®- (Low emission molds require the use of the EZ Lite Remote®).
- 5) Sleeves, packing or other accessories required or suggested.

### Mold Availability:

The mold availability is listed under the lead-time column in the catalog.

- SDS – Same Day Service (*Orders placed by 5:00 pm Central time can ship Same Day*)
- 2 - Ships 2 days following the date the order is placed.
- 4 - Will ship in 4 days ARO (*Design molds will take up to 4 days to ship after receipt of order.*)



*Call Today ship Today!*

# CATHODIC PROTECTION CABLE



Continental Cathodic Protection Cable is designed with durable high molecular weight polyethylene to withstand harsh direct burial conditions. Continental products perform exceptionally in cathodic systems for oil tanks, pipelines, wells, ocean vessels, and steel structures.

**Features:**

- Direct Burial use
- Abrasion Resistant
- Oil Resistant
- Crush Resistant
- Available in 500' and 1000' spools (other spool length available upon request)

**High molecular polyethylene (HMW/PE)**

COPPER CONDUCTOR SIZE	1/0	2 AWG	4 AWG	6 AWG	8 AWG
ITEM NUMBER	36-7716-01	TBD	36-7715-01	36-7714-01	36-7713-01
STRANDING	19	7	7	7	7
JACKET MATERIAL	HMW/PE	HMW/PE	HMW/PE	HMW/PE	HMW/PE
JACKET THICKNESS (IN)	.125"	.110"	.110"	.110"	.110"
INSULATING MATERIAL	N/A	N/A	N/A	N/A	N/A
INSULATING THICKNESS	N/A	N/A	N/A	N/A	N/A
FINISHED O.D. (IN)	.681"	.514"	.453"	.414"	.369"
WEIGHT (PER 1000 FT.)	405 LBS	284 LBS	175 LBS	122 LBS	87 LBS
TEMPERATURE RATING	75°C	75°C	75°C	75°C	75°C
OPERATING VOLTAGE	600v	600v	600v	600v	600v

Applicable ASTM Standards: ASTM B-8, ASTM D1248.



# CATHODIC PROTECTION CABLE



## HMW/PE jacket with Halar (ECTFE) insulation

COPPER CONDUCTOR SIZE	1/0	2 AWG	4 AWG	6 AWG	8 AWG
ITEM NUMBER	TBD	TBD	TBD	TBD	TBD
STRANDING	19	7	7	7	7
JACKET MATERIAL	HMW/PE	HMW/PE	HMW/PE	HMW/PE	HMW/PE
JACKET THICKNESS (IN)	.065"	.065"	.065"	.065"	.065"
INSULATING MATERIAL	HALAR	HALAR	HALAR	HALAR	HALAR
INSULATING THICKNESS	.020"	.020"	.020"	.020"	.020"
FINISHED NOMINAL O.D. (IN)	.59"	.46"	.42"	.35"	.32"
WEIGHT (PER 1000 FT.)	373 LBS	251 LBS	167 LBS	115 LBS	98 LBS
TEMPERATURE RATING	75°C	75°C	75°C	75°C	75°C
VOLTAGE RATING	600v	600v	600v	600v	600v

Applicable ASTM Standards: ASTM B-1, B-3, B-8, B-33, B-172, and B-173 for soft drawn annealed copper conductors. ASTM D1248, D-638, D-639, D-792, D-257, NEMA WC-5, ICEA S-61-402, IEC 60502 for HMWPE. All conductors per UL83.

## HMW/PE with Kynar (PVDF) insulation

COPPER CONDUCTOR SIZE	1/0	2 AWG	4 AWG	6 AWG	8 AWG
ITEM NUMBER	TBD	TBD	TBD	TBD	TBD
STRANDING	19	7	7	7	7
JACKET MATERIAL	HMW/PE	HMW/PE	HMW/PE	HMW/PE	HMW/PE
JACKET THICKNESS (IN)	.065"	.065"	.065"	.065"	.065"
INSULATING MATERIAL	PVDF	PVDF	PVDF	PVDF	PVDF
INSULATING THICKNESS (IN)	.020"	.020"	.020"	.020"	.020"
FINISHED NOMINAL O.D. (IN)	.59"	.46"	.42"	.35"	.32"
WEIGHT (PER 1000 FT.)	374 LBS	252 LBS	168 LBS	116 LBS	99 LBS
TEMPERATURE RATING	75°C	75°C	75°C	75°C	75°C
VOLTAGE RATING	600v	600v	600v	600v	600v

Applicable ASTM Standards: ASTM B-1, B-3, B-8, B-33, B-172, and B-173 for soft drawn annealed copper conductors. ASTM D1248, D-638, D-792, D-257, NEMA WC-5, ICEA S-61-402, IEC 60502 for HMWPE. All conductors per UL83.

# Weld Metal, Tools & Accessories

<b>Description .....</b>	<b>Page #</b>
2.1 EZ Lite Remote® Electric Ignition System .....	14
2.2 Weld Metal.....	15-16
2.3 Tools & Accessories.....	17
2.4 Adapter Sleeves & Hammer die .....	18
2.5 Handle Clamps & Magnetic Mold Support.....	19
2.6 thermOcap & thermOprime.....	20

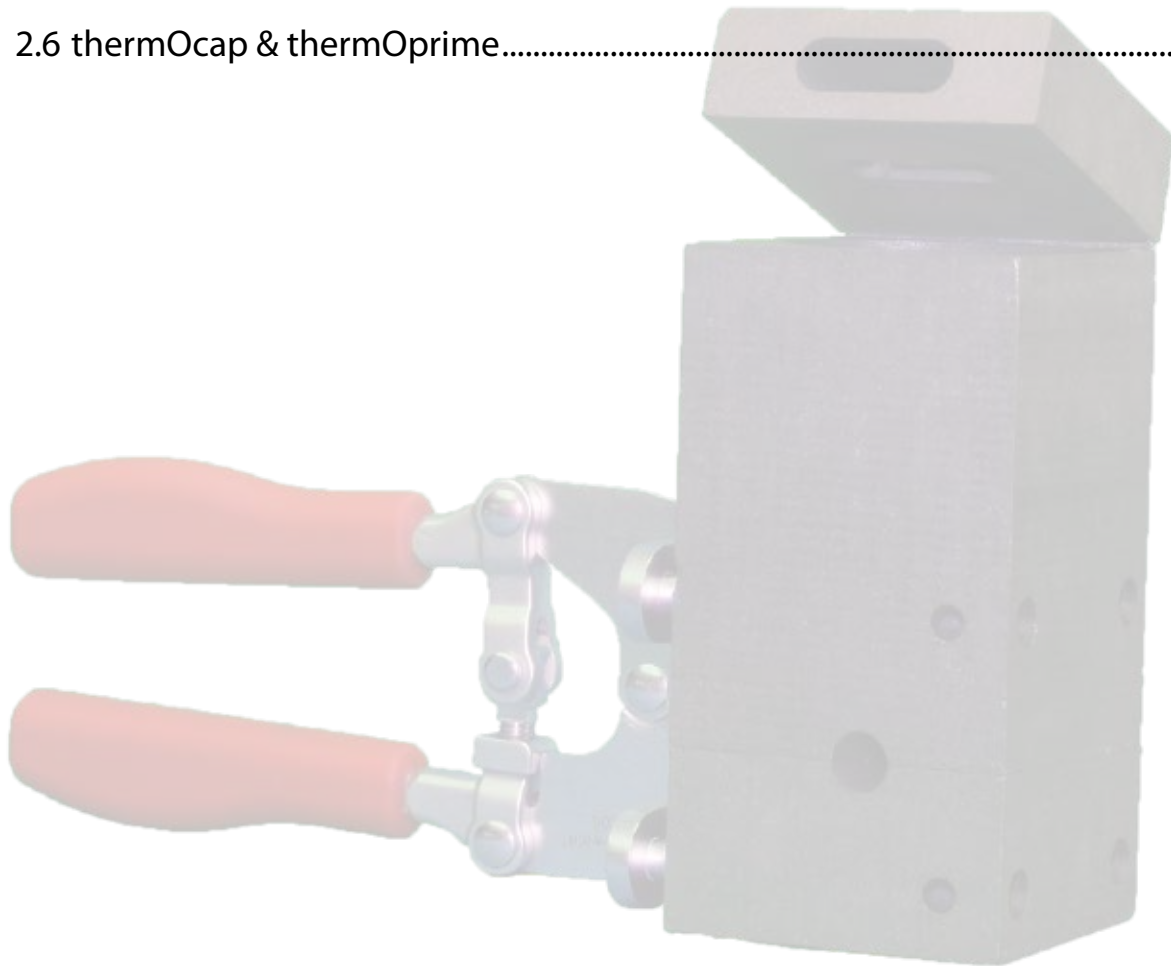

## EZ LITE REMOTE ELECTRIC IGNITION SYSTEM

thermOweld's EZ Lite Remote® is the latest technological advance for thermOweld® exothermic products and the entire industry! For over 50 years, thermOweld® has been developing and inventing products and practical solutions that have become "The Contractor's Choice" worldwide.

With our patent-pended EZ Lite Remote®, the contractor, installer and distributor has versatility and ease-of-use in hand.

Use your existing thermOweld® EZ Lite® molds and weld metal you have today in your truck, at the jobsite or on your shelf!

- Use your Flint ignitor or the EZ Lite Remote® and never be stuck out on the job!
- Have 100% confidence that you will get your connections done when you want!
- Never worry about product obsolescence or dead inventory issues!
- Get it all only from thermOweld®!
- Reliable patented ignitor – 100% guarantee to ignite.
- No starting material needed.
- Use with existing thermOweld EZ Lite® molds and weld metal.
- Triple convenience features – EZ Lite® top light, side vent molds + remote option + famous standard thermOweld® weld metal reliability.
- Quick ignite – no waiting, no guessing.
- Replaceable Alkaline "D" batteries available everywhere give 100's of connections.
- Built-in Battery Life Indicator.
- Separate On/Off and Operate buttons.
- Standard six foot heat-resistant cord and connector; optional lengths available.
- Same Day Service - industry-leading jobsite supply and support, only from thermOweld®.



## EZ LITE REMOTE ELECTRIC IGNITION SYSTEM

EZ Lite Remote® Electric Ignition Catalog #'s		Lead Time
Catalog #	Description	
38-EZLT-RU	EZ Lite Remote® Unit, ready to use with batteries installed at the factory	SDS
38-EZLT-15	EZ Lite Remote® Unit with 15 ft lead, ready to use with batteries installed at the factory	3
38-EZLT-IG	(10) 38-EZLT-IG EZ Lite Remote® Ignitors for use with existing thermOweld® EZ Lite® Molds and weld metal on your shelf, in your truck or at the job site.	SDS
38-EZLT-SK	Starter Kit complete with; (1) 38-EZLT-RU EZ Lite Remote® Unit, ready to use with batteries installed at the factory (20) 38-EZLT-IG EZ Lite Remote® Ignitors for use with existing thermOweld® EZ Lite® Molds and weld metal on your shelf, in your truck or at the job site	SDS
38-EZLT-CA	6 ft. Replacement lead	3
38-EZLT-CX	15 ft. Replacement lead	3
38-EZLT-CY	20 ft. Replacement lead	3

### EZ Lite Remote® Electric Ignition System CP Weld Metal

Pre-packaged Weld Metal with Ignitors		
Cathodic Protection	Cast Iron	Packed per box
TW15CPEZ	—	20
TW25CPEZ	TW25CIEZ	20
TW32CPEZ	TW32CIEZ	10
TW45CPEZ	TW45CIEZ	20
TW65CPEZ	TW65CIEZ	20
thermOweld® Weld Metal is sold in box quantities only		



12 CM  
(Weld Metal)



*Call Today. Ship Today!*

## CP WELD METAL

thermOweld® Cathodic Protection weld metal is the most reliable and consistently-performing weld metal available worldwide. Our continuous-improvement manufacturing process is supplemented with multiple quality validation steps for every lot we produce. Upon final acceptance, our weld metal is specially packaged in moisture-resistant plastic cartridges with special closure caps. Then the cartridges and required metal discs are packaged in moisture-resistant boxes with unique manufacturing lot codes. These lot codes are a thermOweld® innovation, providing complete traceability from raw material origination, through our multiple processing stages to shipment. Finally, thermOweld® applies special shrink-wrap plastic to every weld metal box, insuring reliable storage, positive field ignition and superior welds every time.

Every individual weld metal cartridge is marked with the size and weight in grams for easy identification, even when separated from the host box. thermOweld® weld metal is shipped worldwide to more than 50 countries via ground, air and ocean freight. All sizes of weld metal are available immediately with thermOweld's Same Day Service (SDS) shipment program.

Our engineers have formulated our weld metal for cathodic protection application use.

Standard Cartridge Size	Cathodic Protection Cartridge Size	Cast Iron Cartridge Size	Packed Per Box
#15	#15CP, 15CPS*	—	20
#25	#25CP	#25CI	20
#32	#32CP	#32CI	10
#45	#45CP	#45CI	20
#65	#65CP	#65CI	20
thermOweld® Weld Metal is sold in box quantities only			

\* 15CPS includes: 20 sleeves.

**12 CM**  
(Weld Metal)



### Weld Metal Disks

Weld Metal Disks are used to hold the weld metal in place until the reaction occurs. One disk per weld is required. Disks are included with the weld metal.

Part #37-0320-01 ¾" Dia. Disk (For use w/ #15 thru #65 Weld Metal Cartridges) 20 pack

Part #37-0320-02 1" Dia. Disk (For use w/ #90 thru #115 Weld Metal Cartridges) 10 pack

Part #38-0320-03 1 ½" Dia. Disk (For use w/ #150 thru #500 Weld Metal Cartridges) 10 pack

Part #37-6127-00 Disk Kit (Kit consists of a tube with 25 each of the above disks)





## ACCESSORIES

### 38-0309-00 FLINT IGNITOR

The 38-0309-00 Flint Ignitor is used to ignite the starting powder. Each mold that is sold with a frame has a Flint Ignitor included. Replacement flints are available upon request. Part #38-0309-01.



### 38-0904-00 Flint IGNITOR EXTENSION

The 38-0904-00 Flint Ignitor Extension allows the installer to stand 36" from the mold. Flint Ignitor is included.



### 38-0101-00 RASP

This tempered steel, curved Rasp is recommended for removing rust and mill scale from steel and cast iron surfaces. The blade is replaceable. Specify part # 38-0101-01. Not recommended for use on galvanized surfaces.



### CABLE CLEANING AND CARD CLOTH BRUSH

The Cable Cleaning Brush is recommended for cleaning heavily oxidized cables. The V-shape Brushes permit their use over a wide range of cable sizes. Brush assembly consists of a handle with two stiff wire bristle brushes that are rotatable, for longer life and are replaceable.



38-0135-00

The Card Cloth Brush is used for cleaning large conductors and bus bar. It has short stiff bristles. These brushes are for cleaning cable only, not molds.



38-0306-00

The Mold Cleaning Brush is used to clean the graphite mold without damaging the mold.



38-3922-00

- Cable Cleaning Brush.....38-0135-00
- Replacement Brush.....38-0135-01
- Card Cloth Brush.....38-0306-00
- Mold Cleaning Brush.....38-3922-00

### MOLD CLEANERS

Mold Cleaners are used to clean the slag from molds that are not split through the crucible.

- 40-0319-01..... for cartridge sizes #15 thru #65
- 40-0319-03..... for cartridge sizes #90 thru #500



## ADAPTER SLEEVES

### ADAPTER SLEEVES AND SHIM STOCK

thermOweld® molds designed for larger cable sizes can be used on smaller diameter cables if copper adapter sleeves or shim stock are utilized, except CS-48 and CS-49. The copper shim stock, .0108" x 1-1/2" x 3", is normally wrapped around cable until the diameter is about equal to the cable opening. A tight fit is not necessary as the shim stock will unwrap slightly and prevent leakage of weld metal.

To order shim stock use part # 38-0329-00. Shim stock comes 100 pieces per box.

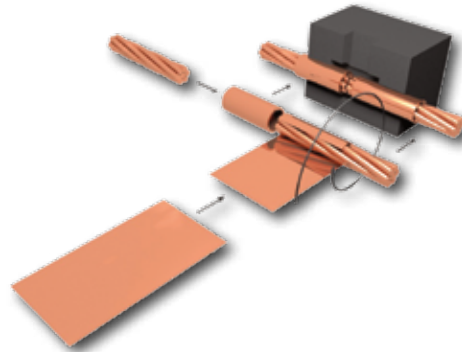

For Use On Cable Size		Catalog #	Use In Mold Size	Sleeve Dimensions		
Stranded	Solid			O.D.	I.D.	Length
#12, #14	#10, #12, #14	38-0200-00	#6 STR & Sol	.156	.111	1.00
#9, #10	#8, #9, #10	38-0208-00	#4 Sol	.203	.140	1.00
#7, #8, #10	#6, #8	38-0201-00	#4	.227	.177	1.00
#6	#5	38-0202-00	#2	.292	.198	1.00
#4, #5	#3, #4	38-0207-00	#2	.287	.246	1.00
#4	#2	38-0204-00	#1	.328	.265	1.00
#2	#1	38-0203-00	1/0	.370	.307	1.00
#1	1/0	38-0209-00	2/0	.420	.359	1.00
1/0, #1	2/0	38-0205-00	3/0 & 4/0 Sol	.452	.389	1.00
2/0, 1/0	3/0	38-0240-00	4/0	.524	.437	1.50



## HAMMER DIES

### HAMMER DIES

Bonds can be made in the field using your own cable, a copper adapter sleeve and a hammer die.

Hammer Die Catalog #	For Use On Cable Size	Adapter Sleeve Catalog #
38-6019-00	#8 Str	38-0201-00
38-6020-00	#6 Str	38-0202-00
38-4859-00	#4 Str	38-0204-00
38-0310-00	#2 Str	38-0203-00
38-0392-00	#1 Str	38-0209-00
38-0311-00	1/0 Str	38-0205-00
38-0312-00	2/0 Str	38-0240-00
38-7292-00	#10 Str	38-0208-00



## HANDLE CLAMPS

### B-106 & B-107 HANDLE CLAMPS

For most connections involving lugs, cable or rectangular bus, thermOweld® Handle Clamps are used. thermOweld® Handle Clamps make possible the use of many different sizes and types of molds with only two different clamps. The two handle clamps are catalog numbers B-106 and B-107. These will fit all of our standard thermOweld® molds.

1. Use B-106 clamps for all molds having a price key 4, 7, 17, 22 or 24. These molds are a nominal 3 1/8" wide molds.
2. Use B-107 clamps for all molds having a price key 5, 6, 8, 13 or 23. These molds are a nominal 4" wide molds.
3. All molds having a price key 2, 3, 9, 10, 11, 12, 14, 15, 16 or 33 have an attached frame; separate handles are not required.

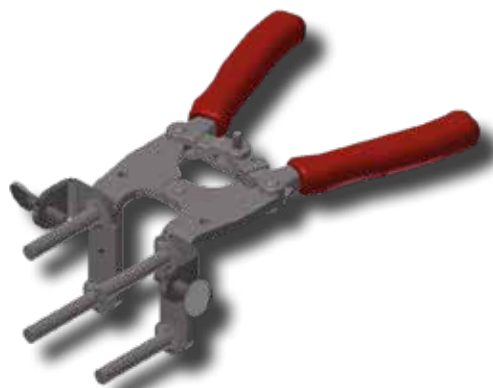

### Cathodic Protection Molds with Magnetic Mold Support

New magnetic mold support is adaptable to all thermOweld® price key 3 molds.

- Designed for remote welding use with the thermOweld® EZ Lite Remote® ignition system
- Strong, 48 lb. Magnet Holds Mold in Place and Prevents Leakage
- Adjustable Height
- Works on Both Cast Iron and Steel Pipe as well as Flat Surfaces
- Available as an accessory which can be attached to any existing thermOweld® Price Key 3 mold in your stock, on your truck, or at the jobsite.

Catalog #	Description
40-7202-00	Price Key 3 Mold Magnet Assembly
To order molds complete with Magnet Assembly, add suffix -M to mold number. Ex. M-100-M	

40-7202-00 ~ Price Key 3 Mold Magnet Assembly

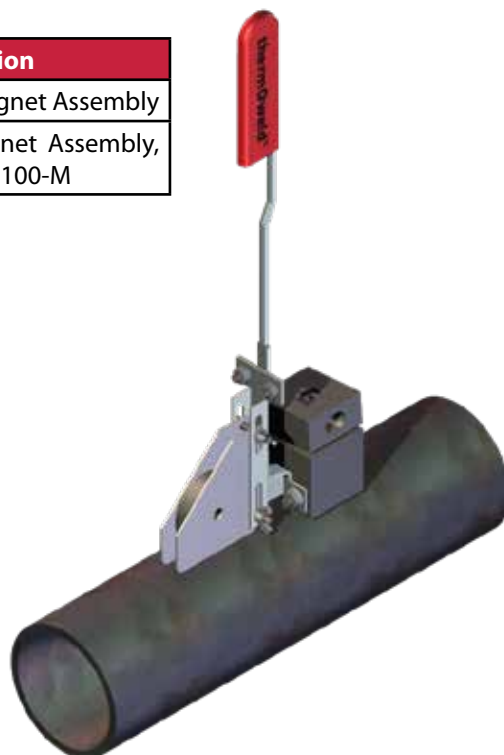
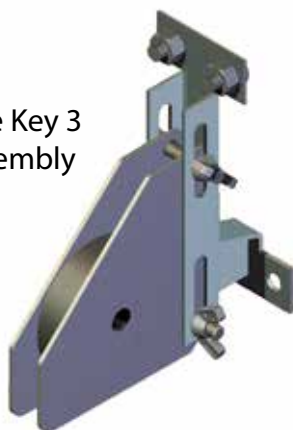

## Ci thermOcap®

**thermOweld®**'s Ci thermOcap® and Ci thermOcap PC® are designed to cover your cathodic protection wire connections on metal pipe and tanks.

- Thick outer shell designed to resist puncture.
- Folds in plastic allow the cap to conform easier to the pipe.
- Butyl rubber filled dome for added corrosion protection for the weld.
- Superior resistance to aging shown through accelerated aging testing.
- Adheres to Ductile Iron, Steel, Stainless Steel, Copper, Aluminum, PVC, PP, PE, FBE powder coating, natural and synthetic rubbers, and Epoxy.
- Outstanding shelf life, resistant to dry rot and cracking.
- Packaged in boxes of 20 with immediate delivery available.
- Works with exothermic and brazed connections
- Ci thermOcap PC is designed to adhere without spray primer. *"Simply peel and stick"!*

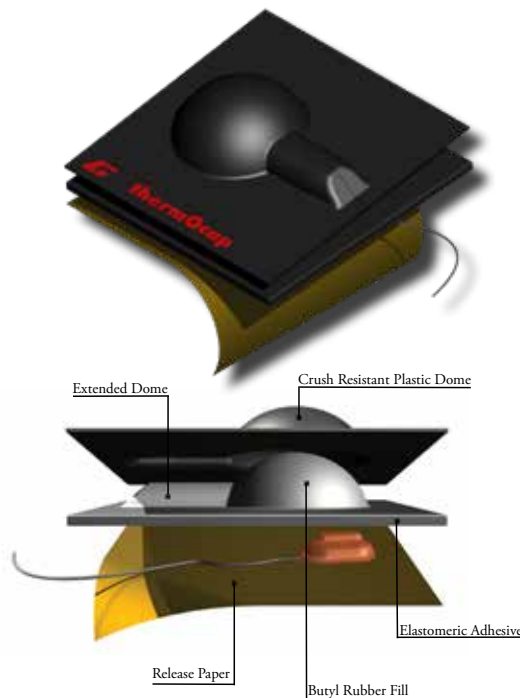

### thermOcap and thermOcap PC Specifications

PROPERTIES		CI THERMOCAP®	CI THERMOCAP PC®
Part Number		38-6687-00	38-6687-02
Dimensions	Overall	4" x 4" (102 mm x 102 mm)	4" x 4" (102 mm x 102 mm)
	Dome	1.75" Dia. 0.75" tall (44.5 mm Dia. 19 mm tall)	1.75" Dia. 0.75" tall (44.5 mm Dia. 19 mm tall)
	Elastomeric Adhesive	0.125" thick (3.2 mm thick)	0.125" thick (3.2 mm thick)
	Plastic Backing	0.021" thick (0.5 mm thick)	0.021" thick (0.5 mm thick)
Primer Required		YES	NO
Application Temperature		35 °F to 125 °F (2 °C to 52 °C)	35 °F to 150 °F (2 °C to 66 °C)
Service Temperature		-20 °F to 225 °F (-29 °C to 107 °C)	-20 °F to 180 °F (-29 °C to 82 °C)
*Adhesion to Steel		15 lb/in (26 N/cm)	15 lb/in (26 N/cm)

\*Determined per ASTM D1000/IEC 6045-2, testing method with minor deviations.

Information contained in this document is for reference only. Customers are responsible for determination of this product's suitability for their application. No liability for any loss related to the use or misuse of the material contained herein is accepted.

### thermOprime





To be used with 38-6687-00 thermOcaps only.



thermOprime liquid adhesive systems consist of butyl based elastomers blended with polymeric resin dissolved on an organic solvent system. They are non-toxic and non-polluting, and conform to local and national standards. In addition to the excellent adhesion to the pipe substrate and cathodic disbondment resistance, the pipe surface is protected against stress corrosion cracking with industry proven SCC inhibitors. Approximately 100 Ci thermOcap® applications per can.



Part Number
38-6769-00

# Cathodic Protection Molds, and Bonds

Weld Type	Page #
	AC Mitigation Mats 31
	CB-1 33
	CC-1 32
	CC-2 33
	CC-6 32
	CP KIT 23
	CR-1 34
	CR-2 34
	CS-32 23

Weld Type	Page #
	CS-33 25
	CS-34 24
	CS-35 25
	CS-36 26
	CS-37 26
	CS-48 27
	CS-49 28
	Jumper Bonds 29-30
	Strap Bonds 31

**APPLICATION NOTES:**

When specifying and applying thermOweld® products for cathodic protection of buried piping systems, it is the specifier and buyer's responsibility to respect the following ASME guidelines in conjunction with ASTM, NACE and applicable country, state, municipality and local guidelines:

ASME B31.8-2000, "Gas Transmission and Distribution Piping Systems"  
862.115 Para (b)1 (steel pipe) 15 grams maximum weld metal cartridge

ASME B31.8-2000, "Gas Transmission and Distribution Piping Systems"  
862.223 Para (a) (ductile / cast iron pipe) 32 grams maximum weld metal cartridge



## SAME DAY SERVICE

(Cathodic Protection Market)

### JUST LIKE HAVING IT ON THE SHELF

#### **MOLDS**

M-100  
M-101  
M-102  
M-103  
M-104  
M-106  
M-142  
M-151  
M-156

#### **WELD METAL**

# 15CP  
# 15CPS  
# 25CI  
# 32CI  
# 45CI

#### **ACCESSORIES**

38-0200-00 Copper Sleeves  
38-0201-00 Copper Sleeves  
38-0207-00 Copper Sleeves

#### **THERMOCAPS**

38-6687-00 Ci thermOcap®  
38-6687-02 Ci thermOcap® PC  
38-6769-00 thermOprime



**4PM**  
CENTRAL STANDARD  
TIME

*Call Today Ship Today!*

\*SDS is not a guaranteed service.

# CS-32

## TYPE MOLDS

**Cathodic Protection  
Horizontal Cable to  
Horizontal Steel Surface  
For AWG Conductors**



**NOTE**

**Welding To Ductile Iron Pipe:** When welding to ductile iron pipe, use weld metal and molds designated for cast iron.

- For sizes not listed, contact thermOweld®.
- Molds listed are for concentric stranded cable. Add suffix "-S" to mold number for solid conductors.
- For expedited service, contact thermOweld®.
- To order weld metal for use with EZ Lite Remote® insert TW before and EZ after weld metal number.
- Required Tools;  
Handle Clamps w/ Flint Ignitor (see chart for correct handles)  
† ~ Sold complete with frame. If frame not required, specify MOLD NUMBER followed by suffix "-G"  
38-0309-00 ~ Flint Ignitor or 38-EZLT-RU EZ Lite Remote®
- Other recommended accessories;  
40-0319-01 ~ Mold Cleaner for cartridge sizes #15-#65  
38-3922-00 ~ Mold Cleaning Brush  
38-0135-00 ~ Cable Cleaning Brush  
38-0101-00 ~ Rasp  
38-4129-00 ~ Packing Material for 1/0 & Larger Molds

MOLDS FOR AWG CONDUCTORS						
Cable Size	Surface	Mold #	Price Key	Weld Metal	Handle Clamps	Lead Time
#6 Sol†	Flat (4" & Larger pipe)	M-100	3	15CP	Included Optional: Magnetic Mold Support, Catalog Number 40-7202-00, See Page 17	SDS
	3/4" to 3 1/2" pipe	M-101	3	15CP		SDS
#6	Flat (4" & Larger pipe)	M-102	3	15CP		SDS
	3/4" to 3 1/2" pipe	M-103	3	15CP		SDS
#4 Sol	Flat (6" & Larger pipe)	M-104	3	15CP		SDS
	3/4" to 3 1/2" pipe	M-105	3	15CP		2
	4" to 5" pipe	M-130	3	15CP		2
#4	Flat (6" & Larger pipe)	M-106	3	15CP		SDS
	3/4" to 3 1/2" pipe	M-107	3	15CP		2
	4" to 5" pipe	M-108	3	15CP		2
#2 Sol	Flat (10" & Larger pipe)	M-109	3	25CP		2
	1" to 3 1/2" pipe	M-110	3	25CP		2
	4" to 8" pipe	M-111	3	25CP		2
#2	Flat (10" & Larger pipe)	M-112	3	32CP		2
	1" to 3 1/2" pipe	M-113	3	32CP	2	
	4" to 8" pipe	M-114	3	32CP	2	
	10" to 14" pipe	M-115	3	32CP	2	
#1	Flat (16" & Larger pipe)	M-116	3	45CP	2	
	1 1/2" to 3 1/2" pipe	M-117	3	45CP	2	
	4" to 8" pipe	M-118	3	45CP	2	
	10" to 14" pipe	M-119	3	45CP	2	
1/0	Flat (20" & Larger pipe)	M-120	3	65CP	2	
	2 1/2" to 3 1/2" pipe	M-121	3	65CP	2	
	4" to 8" pipe	M-122	3	65CP	2	
2/0	10" to 18" pipe	M-123	3	65CP	2	
	Flat (20" & Larger pipe)	M-124	3	65CP	2	
	2 1/2" to 3 1/2" pipe	M-125	3	65CP	2	
	4" to 8" pipe	M-126	3	65CP	2	
	10" to 18" pipe	M-127	3	65CP	2	

† For Wire Size #14 to #10 Solid, 38-0200-00 Sleeve/Weld Req'd

## CP Kit



Each CP Kit Contains		
Flat to 4" & Larger Pipe	3/4" to 3 1/2" & Larger Pipe	Flat 4" & Larger Pipe
(1) M-100 Mold	(1) M-101 Mold	(1) M-102
(80) 15CPS Cartridges*	(80) 15CPS Cartridges*	(80) 15CPS Cartridges*
Flint Ignitor	Flint Ignitor	Flint Ignitor
Mold Cleaner	Mold Cleaner	Mold Cleaner
Part #	Part #	Part #
38-4350-00	38-4351-00	38-7280-00

\* Sleeves are included in weld metal.

Specialty kits are available for other infrastructure applications and unique contractor needs. The NACE-trained staff at thermOweld® is ready to help you with your cathodic protection project.

## CS-34

### TYPE MOLDS

**Cathodic Protection  
Horizontal Thru Cable to  
Horizontal Steel Surface  
For AWG Conductors**



**NOTE**

**Welding To Ductile Iron Pipe:** When welding to ductile iron pipe, use weld metal and molds designated for cast iron.



MOLDS FOR AWG CONDUCTORS						
Cable Size	Surface	Mold #	Price Key	Weld Metal	Handle Clamps	Lead Time
#6 Sol†	Flat (12" & Larger pipe)	M-1955	3	25CP	Included	2
	3/4" to 2" pipe	M-5666	3	25CP		2
	2 1/2" to 5" pipe	M-3097	3	25CP		2
	6" to 10" pipe	M-3141	3	25CP		2
#6	Flat (12" & Larger pipe)	M-5661	3	25CP		2
	3/4" to 2" pipe	M-5662	3	25CP		4
	2 1/2" to 5" pipe	M-5663	3	25CP		2
	6" to 10" pipe	M-5664	3	25CP		2
#4 Sol	Flat (12" & Larger pipe)	M-1956	3	25CP		4
	3/4" to 2" pipe	M-1957	3	25CP		2
	2 1/2" to 5" pipe	M-1958	3	25CP		2
	6" to 10" pipe	M-1966	3	25CP		4
#4	Flat (12" & Larger pipe)	M-6000	3	25CP		2
	3/4" to 2" pipe	M-1967	3	25CP		2
	2 1/2" to 5" pipe	M-5501	3	25CP		2
	6" to 10" pipe	M-5503	3	25CP		2
#2 Sol	Flat (14" & Larger pipe)	M-5505	3	32CP		4
	2" to 3 1/2" pipe	M-5507	3	32CP	4	
	4" to 8" pipe	M-5510	3	32CP	2	
	10" to 16" pipe	M-5514	3	32CP	2	
#2	Flat (14" & Larger pipe)	M-5518	3	45CP	2	
	2" to 3 1/2" pipe	M-5986	3	45CP	2	
	4" to 8" pipe	M-5605	3	45CP	2	
	10" to 16" pipe	M-5988	3	45CP	4	
#1	Flat (18" & Larger pipe)	M-5519	3	45CP	4	
	2" to 3 1/2" pipe	M-5520	3	45CP	4	
	4" to 8" pipe	M-5521	3	45CP	4	
	10" to 16" pipe	M-5523	3	45CP	4	
1/0	Flat (30" & Larger pipe)	M-5524	3	65CP	4	
	3" to 4" pipe	M-5525	3	65CP	4	
	5" to 6" pipe	M-5526	3	65CP	4	
	8" to 10" pipe	M-5527	3	65CP	2	
2/0	Flat (30" & Larger pipe)	M-5529	3	65CP	4	
	3" to 4" pipe	M-6251	3	65CP	4	
	5" to 6" pipe	M-5530	3	65CP	4	
	8" to 10" pipe	M-5531	3	65CP	2	
	12" to 28" pipe	M-5532	3	65CP	4	
	Flat (30" & Larger pipe)	M-5533	3	65CP	4	
	3" to 4" pipe	M-5530	3	65CP	4	
	5" to 6" pipe	M-5531	3	65CP	4	
	8" to 10" pipe	M-5532	3	65CP	2	
	12" to 28" pipe	M-5533	3	65CP	4	

Optional: Magnetic Mold Support, Catalog Number 40-7202-00, See Page 17

‡ For Wire Size #14 to #10 Solid, (2) 38-0200-00 Sleeves/Weld Req'd

- For sizes not listed, contact thermOweld®.
- Molds listed are for concentric stranded cable. Add suffix "-S" to mold number for solid conductors.
- For expedited service, contact thermOweld®.
- To order weld metal for use with EZ Lite Remote® insert TW before and EZ after weld metal number.
- Required Tools;
  - Handle Clamps w/ Flint Ignitor (see chart for correct handles)
  - † ~ Sold complete with frame If frame not required, specify MOLD NUMBER followed by suffix "-G"
  - 38-0309-00 ~ Flint Ignitor or 38-EZLT-RU EZ Lite Remote®
- Other recommended accessories;
  - 40-0319-01 ~ Mold Cleaner for cartridge sizes #15-#65
  - 38-3922-00 ~ Mold Cleaning Brush
  - 38-0135-00 ~ Cable Cleaning Brush
  - 38-0101-00 ~ Rasp
  - 38-4129-00 ~ Packing Material for 1/0 & Larger Molds



# CS-33

## TYPE MOLDS

Cathodic Protection  
Horizontal Cable to  
Horizontal Cast Iron Surface  
For AWG Conductors

MOLDS FOR AWG CONDUCTORS						
Cable Size	Surface	Mold #	Price Key	Weld Metal	Handle Clamps	Lead Time
#6 Sol†	Flat (30" & larger pipe)	M-156	3	25CI	Included Optional: Magnetic Mold Support, Catalog Number 40-7202-00, See Page 17	SDS
#6	Flat (30" & larger pipe)	M-157	3	25CI		2
#4 Sol	Flat (30" & larger pipe)	M-158	3	45CI		2
#4	Flat (30" & larger pipe)	M-159	3	45CI		2
#2 Sol	Flat (30" & larger pipe)	M-160	3	45CI		2
#2	Flat (30" & larger pipe)	M-161	3	45CI		2
#1	Flat (30" & larger pipe)	M-163	3	65CI		2

† For Wire Size #14 to #10 Solid, 38-0200-00 Sleeve/Weld Req'd

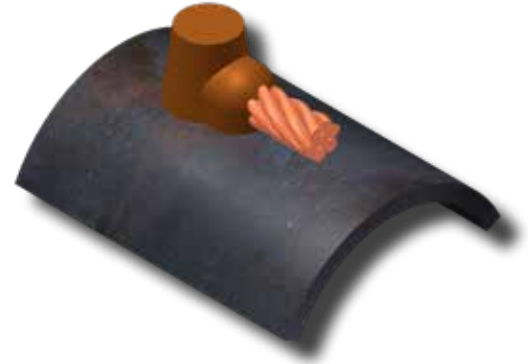

# CS-35

## TYPE MOLDS

Cathodic Protection  
Horizontal Thru Cable to  
Horizontal Cast Iron Surface  
For AWG Conductors

MOLDS FOR AWG CONDUCTORS						
Cable Size	Surface	Mold #	Price Key	Weld Metal	Handle Clamps	Lead Time
#6 Sol†	Flat (30" & larger pipe)	M-5316	3	32CI	Included Optional: Magnetic Mold Support, Catalog Number 40-7202-00, See Page 17	4
#6	Flat (30" & larger pipe)	M-5535	3	32CI		4
#4 Sol	Flat (30" & larger pipe)	M-5536	3	45CI		4
#4	Flat (30" & larger pipe)	M-5537	3	45CI		2
#2 Sol	Flat (30" & larger pipe)	M-5538	3	45CI		4
#2	Flat (30" & larger pipe)	M-5540	3	45CI		2
#1	Flat (30" & larger pipe)	M-5542	3	65CI		4

† For Wire Size #14 to #10 Solid, (2) 38-0200-00 Sleeves/Weld Req'd



**Welding To Horizontal Pipe:** To weld to 4" to 24" horizontal pipe, add pipe size to mold number. Example: To weld #1 str cable to 6" horizontal pipe, the mold number would be M-163-6. To weld to pipe 30" and larger, use flat surface mold.

**DO NOT use Type CS-33 or CS-35 molds on Soil Pipe (ASTM A74-82). A test weld should be made on a section of the pipe being used to determine the possibility of detrimental metallurgical effects.**

- **For sizes not listed, contact thermOweld®.**
- Molds listed are for concentric stranded cable. Add suffix "-S" to mold number for solid conductors.
- For expedited service, contact thermOweld®.
- To order weld metal for use with EZ Lite Remote® insert TW before and EZ after weld metal number.
- Required Tools;
  - Handle Clamps w/ Flint Ignitor (see chart for correct handles)
  - † ~ Sold complete with frame If frame not required, specify MOLD NUMBER followed by suffix "-G"
  - 38-0309-00 ~ Flint Ignitor or 38-EZLT-RU EZ Lite Remote®
- Other recommended accessories;
  - 40-0319-01 ~ Mold Cleaner for cartridge sizes #15-#65
  - 38-3922-00 ~ Mold Cleaning Brush
  - 38-0135-00 ~ Cable Cleaning Brush
  - 38-0101-00 ~ Rasp
  - 38-4129-00 ~ Packing Material for 1/0 & Larger Molds

## CS-36

### TYPE MOLDS

**Cathodic Protection  
Cable to Vertical Steel Surface  
For AWG Conductors**

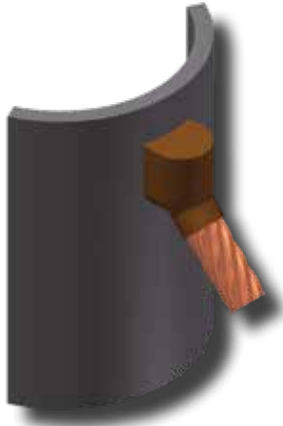

**NOTE**

**Welding To Ductile Iron Pipe:** When welding to ductile iron pipe, use weld metal and molds designated for cast iron.

MOLDS FOR AWG CONDUCTORS						
Cable Size	Surface	Mold #	Price Key	Weld Metal	Handle Clamps	Lead Time
#6 Sol†	Flat (12" & Larger pipe)	M-142	18 †	15CP	40-4565-00	SDS
	3/4" to 3 1/2" pipe	M-150	18 †	15CP	40-4565-00	2
	4" to 10" pipe	M-151	18 †	15CP	40-4565-00	SDS
#6	Flat (12" & Larger pipe)	M-144	18 †	15CP	40-4565-00	2
	3/4" to 3 1/2" pipe	M-152	18 †	15CP	40-4565-00	2
	4" to 10" pipe	M-153	18 †	15CP	40-4565-00	2
#4 Sol	Flat (12" & Larger pipe)	M-145	18 †	25CP	40-4565-00	2
	3/4" to 1 1/2" pipe	M-186	18 †	25CP	40-4565-00	2
	2" to 4" pipe	M-187	18 †	25CP	40-4565-00	2
	5" to 10" pipe	M-188	18 †	25CP	40-4565-00	2
#4	Flat (12" & Larger pipe)	M-146	18 †	25CP	40-4565-00	2
	3/4" to 1 1/2" pipe	M-189	18 †	25CP	40-4565-00	2
	2" to 4" pipe	M-190	18 †	25CP	40-4565-00	2
	5" to 10" pipe	M-191	18 †	25CP	40-4565-00	2
#2 Sol	Flat (14" & Larger pipe)	M-147	18 †	25CP	40-4565-00	2
	1" to 1 1/2" pipe	M-192	18 †	25CP	40-4565-00	2
	2" to 4" pipe	M-193	18 †	25CP	40-4565-00	2
#2	5" to 12" pipe	M-194	18 †	25CP	40-4565-00	2
	Flat (14" & Larger pipe)	M-148	18 †	32CP	40-4565-00	2
	1" to 1 1/2" pipe	M-195	18 †	32CP	40-4565-00	2
	2" to 3" pipe	M-196	18 †	32CP	40-4565-00	2
	4" to 6" pipe	M-197	18 †	32CP	40-4565-00	2
#1	8" to 12" pipe	M-198	18 †	32CP	40-4565-00	2
	Flat (18" & Larger pipe)	M-6117	19 †	45CP	40-4565-00	4
	1 1/2" to 2 1/2" pipe	M-6118	19 †	45CP	40-4565-00	2
	3" to 4" pipe	M-6119	19 †	45CP	40-4565-00	2
#1	5" to 10" pipe	M-6120	19 †	45CP	40-4565-00	2
	12" to 16" pipe	M-6121	19 †	45CP	40-4565-00	2

† For Wire Size #14 to #10 Solid, 38-0200-00 Sleeve/Weld Req'd

## CS-37

### TYPE MOLDS

**Cathodic Protection  
Cable to Vertical Cast Iron  
For AWG Conductors**



MOLDS FOR AWG CONDUCTORS						
Cable Size	Surface	Mold #	Price Key	Weld Metal	Handle Clamps	Lead Time
#6 Sol†	Flat (30" & larger pipe)	M-2594-S	18 †	25CI	40-4565-00	2
#6	Flat (30" & larger pipe)	M-2594	18 †	25CI	40-4565-00	2
#4 Sol	Flat (30" & larger pipe)	M-2595-S	18 †	32CI	40-4565-00	4
#4	Flat (30" & larger pipe)	M-2595	18 †	32CI	40-4565-00	2
#2 Sol	Flat (30" & larger pipe)	M-2596-S	19 †	45CI	40-4565-00	4
#2	Flat (30" & larger pipe)	M-2596	19 †	45CI	40-4565-00	2
#1	Flat (30" & larger pipe)	M-2597	19 †	65CI	40-4565-00	4

† For Wire Size #14 to #10 Solid, 38-0200-00 Sleeve/Weld Req'd

- For sizes not listed, contact thermOweld®.
- Molds listed are for concentric stranded cable. Add suffix "-S" to mold number for solid conductors.
- For expedited service, contact thermOweld®.
- To order weld metal for use with EZ Lite Remote® insert TW before and EZ after weld metal number.
- Required Tools;
  - Handle Clamps w/ Flint Ignitor (see chart for correct handles)
  - † ~ Sold complete with handles. If not required, specify MOLD NUMBER followed by suffix "-G".
  - 38-0309-00 ~ Flint Ignitor or 38-EZLT-RU EZ Lite Remote®
- Other recommended accessories;
  - 40-0319-01 ~ Mold Cleaner for cartridge sizes #15-#65
  - 38-3922-00 ~ Mold Cleaning Brush
  - 38-0135-00 ~ Cable Cleaning Brush
  - 38-0101-00 ~ Rasp

**DO NOT use Type CS-37 molds on Soil Pipe (ASTM A74-82). A test weld should be made on a section of the pipe being used to determine the possibility of detrimental metallurgical effects.**

**Welding To Vertical Pipe (CS-37 only):** To weld to 4" to 24" vertical pipe, add pipe size to mold number. Example: To weld #1 str cable to 6" vertical pipe, the mold number would be M-2597-V6. To weld to pipe 30" and larger, use flat surface mold.

CS-48

TYPE MOLDS

Cathodic Protection

Field Made Bond to Horizontal Steel Surface

For AWG Conductors



MOLDS FOR AWG CONDUCTORS								
CS-48 MOLD INFORMATION FOR STEEL PIPE								
Bond Size	Surface	Mold #	Price Key	Weld Metal	Copper Adapter Sleeves	Hammer Die	Handle Clamps	Lead Time
#8	4" pipe	M-11379	3†	15CP	38-0201-00	38-6019-00	Included Optional: Magnetic Mold Support, Catalog Number 40-7202-00, See Page 17	4
	6" to 8" pipe	M-11380	3†	15CP				4
	10" & Larger pipe	M-7339	3†	15CP				4
#6	4" pipe	M-7343	3†	15CP	38-0202-00	38-6020-00		4
	6" to 8" pipe	M-7344	3†	15CP				4
	10" & Larger pipe	M-7342	3†	15CP				2
#4	4" pipe	M-7346	3†	25CP	38-0204-00	38-4859-00		4
	6" to 8" pipe	M-7347	3†	25CP				2
	10" & Larger pipe	M-7345	3†	25CP				2
#2	4" pipe	M-7336	3†	25CP	38-0203-00	38-0310-00	2	
	6" to 8" pipe	M-131	3†	25CP			2	
	10" & Larger pipe	M-129	3†	25CP			2	
#1	4" pipe	M-7349	3†	32CP	38-0209-00	38-0392-00	4	
	6" to 8" pipe	M-7350	3†	32CP			4	
	10" & Larger pipe	M-7348	3†	32CP			2	
1/0	4" pipe	M-7337	3†	32CP	38-0205-00	38-0311-00	4	
	6" to 8" pipe	M-134	3†	32CP			4	
	10" & Larger pipe	M-132	3†	32CP			2	
2/0	4" pipe	M-7338	3†	45CP	38-0240-00	38-0312-00	4	
	6" to 8" pipe	M-137	3†	45CP			4	
	10" & Larger pipe	M-135	3†	45CP			4	

**DO NOT use Type CS-49 molds on Soil Pipe (ASTM A74-82). A test weld should be made on a section of the pipe being used to determine the possibility of detrimental metallurgical effects.**

- For sizes not listed, contact thermOweld®.
- Molds listed are for concentric stranded cable. Add suffix "-S" to mold number for solid conductors.
- For expedited service, contact thermOweld®.
- To order weld metal for use with EZ Lite Remote® insert TW before and EZ after weld metal number.
- Required Tools;
  - Handle Clamps w/ Flint Ignitor (see chart for correct handles)
  - † ~ Sold complete with frame. If frame not required, specify MOLD NUMBER followed by suffix "-G"
  - 38-0309-00 ~ Flint Ignitor or 38-EZLT-RU EZ Lite Remote®
- Other recommended accessories;
  - 40-0319-01 ~ Mold Cleaner for cartridge sizes #15-#65
  - 38-3922-00 ~ Mold Cleaning Brush
  - 38-0135-00 ~ Cable Cleaning Brush
  - 38-0101-00 ~ Rasp
  - 38-4129-00 ~ Packing Material for 1/0 & Larger Molds

## CS-49

### TYPE MOLDS

Cathodic Protection

Field Made Bond to Cast Iron Surface

For AWG Conductors



MOLDS FOR AWG CONDUCTORS								
CS-49 MOLD INFORMATION FOR CAST IRON PIPE								
Bond Size	Surface	Mold #	Price Key	Weld Metal	Copper Adapter Sleeves	Hammer Die	Handle Clamps	Lead Time
#8	4" to 24" pipe: Replace P.S. with Pipe Size (Ex. M-7351-4 for 4" Pipe)	M-7351-P.S.	3†	25CI	38-0201-00	38-6019-00	Included Optional: Magnetic Mold Support, Catalog Number 40-7202-00, See Page 17	2
	30" & Larger pipe	M-7351	3†	25CI				2
#6	4" to 24" pipe: Replace P.S. with Pipe Size (Ex. M-7352-4 for 4" Pipe)	M-7352-P.S.	3†	25CI	38-0202-00	38-6020-00		2
	30" & Larger pipe	M-7352	3†	25CI				2
#4	4" to 24" pipe: Replace P.S. with Pipe Size (Ex. M-0154-4 for 4" Pipe)	M-154-P.S.	3†	32CI	38-0204-00	38-4859-00		2
	30" & Larger pipe	M-154	3†	32CI				2
#2	4" to 24" pipe: Replace P.S. with Pipe Size (Ex. M-0175-4 for 4" Pipe)	M-175-P.S.	3†	32CI	38-0203-00	38-0310-00		4
	30" & Larger pipe	M-175	3†	32CI				2
#1	4" to 24" pipe: Replace P.S. with Pipe Size (Ex. M-7354-4 for 4" Pipe)	M-7354-P.S.	3†	45CI	38-0209-00	38-0392-00		4
	30" & Larger pipe	M-7354	3†	45CI				4
1/0	4" to 24" pipe: Replace P.S. with Pipe Size (Ex. M-5809-4 for 4" Pipe)	M-5809-P.S.	3†	45CI	38-0205-00	38-0311-00		2
	30" & Larger pipe	M-5809	3†	45CI				2
2/0	4" to 24" pipe: Replace P.S. with Pipe Size (Ex. M-7355-4 for 4" Pipe)	M-7355-P.S.	3†	45CI	38-0240-00	38-0312-00		4
	30" & Larger pipe	M-7355	3†	45CI				4

**DO NOT use Type CS-49 molds on Soil Pipe (ASTM A74-82). A test weld should be made on a section of the pipe being used to determine the possibility of detrimental metallurgical effects.**

- For sizes not listed, contact thermOweld®.
- Molds listed are for concentric stranded cable. Add suffix "-S" to mold number for solid conductors.
- For expedited service, contact thermOweld®.
- To order weld metal for use with EZ Lite Remote® insert TW before and EZ after weld metal number.
- Required Tools;
  - Handle Clamps w/ Flint Ignitor (see chart for correct handles)
  - † ~ Sold complete with frame If frame not required, specify MOLD NUMBER followed by suffix "-G"
  - 38-0309-00 ~ Flint Ignitor or 38-EZLT-RU EZ Lite Remote®
- Other recommended accessories;
  - 40-0319-01 ~ Mold Cleaner for cartridge sizes #15-#65
  - 38-3922-00 ~ Mold Cleaning Brush
  - 38-0135-00 ~ Cable Cleaning Brush
  - 38-0101-00 ~ Rasp
  - 38-4129-00 ~ Packing Material for 1/0 & Larger Molds

# JUMPER BONDS

Factory made jumper bonds come in multiple wire gauge, length, and end configurations; without sleeves, rounded sleeves, and formed sleeves. See page 25 and 26 for the appropriate molds for connecting jumper bonds to steel or cast iron services.



### Jumper Bond without Sleeve

Part Number	Description
27-6997-18	#2 AWG HMW.PE x 18" Long w/out Sleeves
27-6997-24	#2 AWG HMW.PE x 24" Long w/out Sleeves
27-6997-36	#2 AWG HMW.PE x 36" Long w/out Sleeves
27-6997-48	#2 AWG HMW.PE x 48" Long w/out Sleeves
27-6523-18	#4 AWG HMW.PE x 18" Long w/out Sleeves
27-6523-24	#4 AWG HMW.PE x 24" Long w/out Sleeves
27-6523-36	#4 AWG HMW.PE x 36" Long w/out Sleeves
27-6523-48	#4 AWG HMW.PE x 48" Long w/out Sleeves
27-6998-18	#6 AWG HMW.PE x 18" Long w/out Sleeves
27-6998-24	#6 AWG HMW.PE x 24" Long w/out Sleeves
27-6998-36	#6 AWG HMW.PE x 36" Long w/out Sleeves
27-6998-48	#6 AWG HMW.PE x 48" Long w/out Sleeves
27-6998-48	#6 AWG HMW.PE x 48" Long w/out Sleeves
27-6999-18	#8 AWG HMW.PE x 18" Long w/out Sleeves
27-6999-24	#8 AWG HMW.PE x 24" Long w/out Sleeves
27-6999-36	#8 AWG HMW.PE x 36" Long w/out Sleeves
27-6999-48	#8 AWG HMW.PE x 48" Long w/out Sleeves
27-7102-18	#10 AWG HMW.PE x 18" Long w/out Sleeves
27-7102-24	#10 AWG HMW.PE x 24" Long w/out Sleeves
27-7102-36	#10 AWG HMW.PE x 36" Long w/out Sleeves
27-7102-48	#10 AWG HMW.PE x 48" Long w/out Sleeves
27-7105-18	#12 AWG HMW.PE x 18" Long w/out Sleeves
27-7105-24	#12 AWG HMW.PE x 24" Long w/out Sleeves
27-7105-36	#12 AWG HMW.PE x 36" Long w/out Sleeves
27-7105-48	#12 AWG HMW.PE x 48" Long w/out Sleeves

• For sizes not listed, contact thermOweld®.

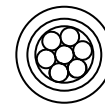

End View of Bond

### Jumper Bond with Round Sleeve

Part Number	Description
27-7095-18	#2 AWG HMW.PE x 18" Long w/ Round Sleeves
27-7095-24	#2 AWG HMW.PE x 24" Long w/ Round Sleeves
27-7095-36	#2 AWG HMW.PE x 36" Long w/ Round Sleeves
27-7095-48	#2 AWG HMW.PE x 48" Long w/ Round Sleeves
27-7096-18	#4 AWG HMW.PE x 18" Long w/ Round Sleeves
27-7096-24	#4 AWG HMW.PE x 24" Long w/ Round Sleeves
27-7096-36	#4 AWG HMW.PE x 36" Long w/ Round Sleeves
27-7096-48	#4 AWG HMW.PE x 48" Long w/ Round Sleeves
27-7097-18	#6 AWG HMW.PE x 18" Long w/ Round Sleeves
27-7097-24	#6 AWG HMW.PE x 24" Long w/ Round Sleeves
27-7097-36	#6 AWG HMW.PE x 36" Long w/ Round Sleeves
27-7097-48	#6 AWG HMW.PE x 48" Long w/ Round Sleeves
27-7098-18	#8 AWG HMW.PE x 18" Long w/ Round Sleeves
27-7098-24	#8 AWG HMW.PE x 24" Long w/ Round Sleeves
27-7098-36	#8 AWG HMW.PE x 36" Long w/ Round Sleeves
27-7098-48	#8 AWG HMW.PE x 48" Long w/ Round Sleeves
27-7101-18	#10 AWG HMW.PE x 18" Long w/ Round Sleeves
27-7101-24	#10 AWG HMW.PE x 24" Long w/ Round Sleeves
27-7101-36	#10 AWG HMW.PE x 36" Long w/ Round Sleeves
27-7101-48	#10 AWG HMW.PE x 48" Long w/ Round Sleeves

• For sizes not listed, contact thermOweld®.

# JUMPER BONDS



Flat

End View of Bond

Jumper Bond with Formed Sleeve

Part Number	Description
27-6378-18	#2 AWG HMW,PE x 18" Long w/ Formed Sleeves
27-6378-24	#2 AWG HMW,PE x 24" Long w/ Formed Sleeves
27-6378-36	#2 AWG HMW,PE x 36" Long w/ Formed Sleeves
27-6378-48	#2 AWG HMW,PE x 48" Long w/ Formed Sleeves
27-6426-18	#4 AWG HMW,PE x 18" Long w/ Formed Sleeves
27-6426-24	#4 AWG HMW,PE x 24" Long w/ Formed Sleeves
27-6426-36	#4 AWG HMW,PE x 36" Long w/ Formed Sleeves
27-6426-48	#4 AWG HMW,PE x 48" Long w/ Formed Sleeves
27-6540-18	#6 AWG HMW,PE x 18" Long w/ Formed Sleeves
27-6540-24	#6 AWG HMW,PE x 24" Long w/ Formed Sleeves
27-6540-36	#6 AWG HMW,PE x 36" Long w/ Formed Sleeves
27-6540-48	#6 AWG HMW,PE x 48" Long w/ Formed Sleeves
27-6570-18	#8 AWG HMW,PE x 18" Long w/ Formed Sleeves
27-6570-24	#8 AWG HMW,PE x 24" Long w/ Formed Sleeves
27-6570-36	#8 AWG HMW,PE x 36" Long w/ Formed Sleeves
27-6570-48	#8 AWG HMW,PE x 48" Long w/ Formed Sleeves
27-7100-18	#10 AWG HMW,PE x 18" Long w/ Formed Sleeves
27-7100-24	#10 AWG HMW,PE x 24" Long w/ Formed Sleeves
27-7100-36	#10 AWG HMW,PE x 36" Long w/ Formed Sleeves
27-7100-48	#10 AWG HMW,PE x 48" Long w/ Formed Sleeves

• For sizes not listed, contact thermOweld®.

Factory made Jumper Bonds with pigtails are used bonding across Dresser Style Couplings.



BOND INFORMATION			
Bond Size	Pigtail Size	Length	Catalog #
#4 Str	#12 Sol	24"	27-6644-00
#2 Str	#12 Sol	24"	27-6412-00

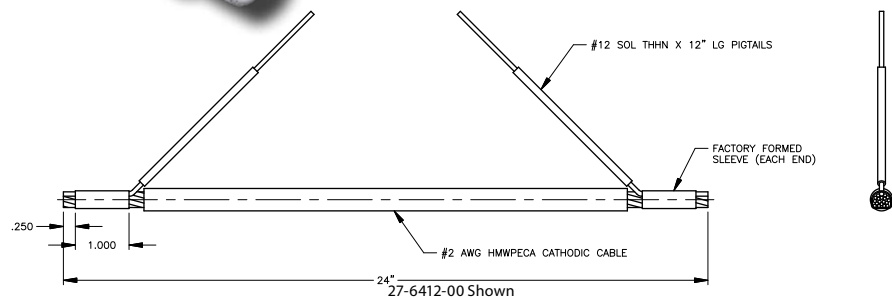

CS-48 MOLD INFORMATION FOR STEEL PIPE				CS-32 MOLD FOR PIGTAIL TO STEEL PIPE			BOND SIZE	CS-49 MOLD INFORMATION FOR CAST IRON PIPE				CS-33 MOLD FOR PIGTAIL TO CAST IRON PIPE		
Surface	Mold #	Price Key	Weld Metal	Mold #	Price Key	Weld Metal		Surface	Mold #	Price Key	Weld Metal	Mold #	Price Key	Weld Metal
4" pipe	M-7336	3	25CP	M-100	3	15CP	#2 Str	4" to 24" pipe	M-175-P.S.	3	32CI	M-156-P.S.	3	25CI
6" to 8" pipe	M-131	3	25CP	M-100	3	15CP		30" & Larger pipe	M-175	3	32CI	M-156	3	25CI
10" & Larger pipe	M-129	3	25CP	M-100	3	15CP		Replace P.S. with Pipe Size (Ex. M-156-4 for 4" Pipe)						

• For sizes not listed, contact thermOweld®.

**DO NOT use Type CS-32 or CS-48 molds on Soil Pipe (ASTM A74-82). A test weld should be made on a section of the pipe being used to determine the possibility of detrimental metallurgical effects.**

# STRAP BONDS



The Strap Bond is a method of bonding across joints. It is particularly suited for providing electrical contact across Dresser® Couplers. The strap is made of soft copper strip available in size equivalent to 1/0 str. copper and supplied to desired length. The soft copper allows easy hand forming of the strap to the coupler contour. Normal application requires 5 welds, 2 on the pipe and 3 on the coupler. Welds are made with mold M-128 sold complete with handle, cleaning tool and flint ignitor. Requires #15CP cartridge for each weld.

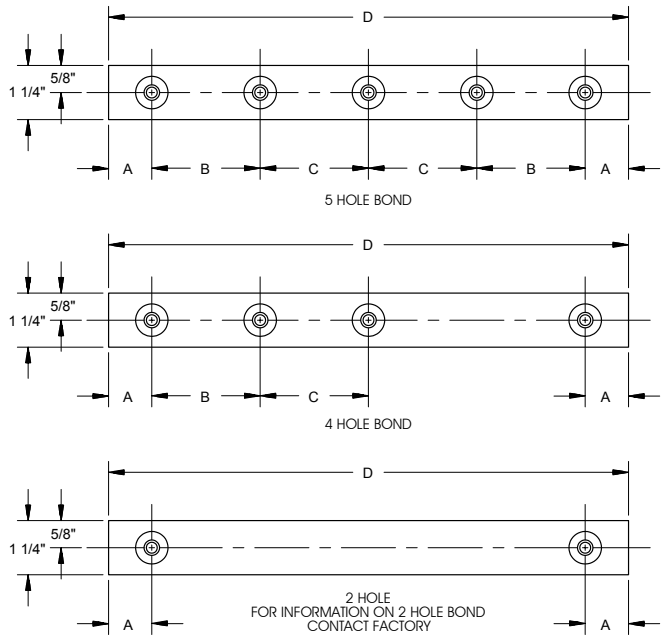

COPPER STRAP BONDS						
Coupling Size	Catalog #	# of Holes	A	B	C	D
5" & Larger Pipe Style 38	27-0180-00	4	1"	3 3/4"	5 1/4"	20"
5" & Larger Pipe Style 38	27-0181-00	4	1"	3 3/4"	6 1/4"	22"
5" & Larger Pipe Style 38	27-0182-00	5	1"	3 3/4"	5 1/4"	20"
5" & Larger Pipe Style 38	27-0183-00	5	1"	3 3/4"	6 1/4"	22"
Under 5" & Light Pattern Style 38	27-0184-00	4	1"	3 1/4"	4 1/4"	17"
Under 5" & Light Pattern Style 38	27-0185-00	4	1"	3 1/4"	5 1/4"	19"
Under 5" & Light Pattern Style 38	27-0186-00	5	1"	3 1/4"	4 1/4"	17"
Under 5" & Light Pattern Style 38	27-0187-00	5	1"	3 1/4"	5 1/4"	19"
For All Style 40 Couplings Use (2) 27-0188-00 Bonds	27-0188-00	3	1"	3 3/4"	—	9 1/2"
N/A	27-2745-00	2	1"	—	—	20"
N/A	27-2745-01	2	1"	—	—	17"
N/A	27-2745-02	2	1"	—	—	18"
N/A	27-2745-03	2	1"	—	—	11"

- For sizes not listed, contact thermOweld®.
- Current capacity of the copper strap bonds is equivalent to 1/0 Str copper cable.
- Use Mold M-128 to attach bonds with #15 cartridge.

# AC MITIGATION MATS

AC Mitigation Mats are used near pipelines when the structure is above the grade to limit step and touch potentials. AC Mitigation mats are hot dip zinc galvanized and come in the standard size of 4ft x 8ft with 3" x 3" squares.

Catalog Number	Size
38-6855-00	4' x 8'

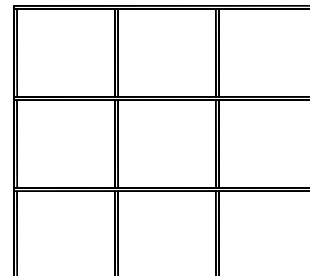

## CC-1

### TYPE MOLDS

Horizontal End to End

For AWG Conductors

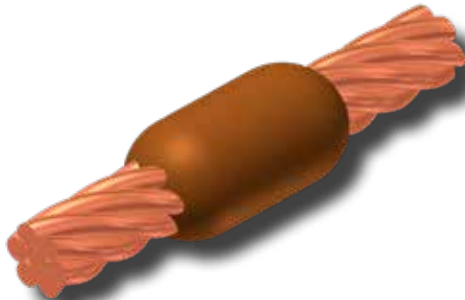

MOLDS FOR AWG CONDUCTORS					
Cable	Mold #	Price Key	Weld Metal	Handle Clamps	Lead Time
#12 Sol	M-8224-S	18	15	40-4565-00	4
#10 Sol	M-8225-S	18	15	40-4565-00	2
#8 Sol	M-8228-S	18	15	40-4565-00	2
#6 Sol	M-8229-S	18	25	40-4565-00	2
#6	M-8229	18	25	40-4565-00	2
#4 Sol	M-8232-S	18	25	40-4565-00	4
#4	M-8232	18	25	40-4565-00	2
#2 Sol	M-8235-S	18	32	40-4565-00	2
#2	M-8235	18	32	40-4565-00	2
#1	M-8239	18	32	40-4565-00	4
1/0	M-8242	19	45	40-4565-00	2
2/0	M-8244	19	65	40-4565-00	2

## CC-6

### TYPE MOLDS

Horizontal Parallel Tap

For AWG Conductors

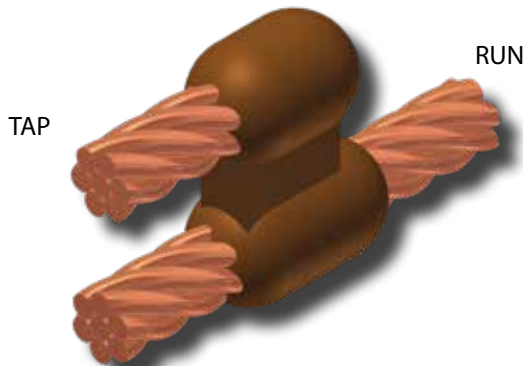

MOLDS FOR AWG CONDUCTORS						
Cable	Mold #	Price Key	Weld Metal	Handle Clamps	Lead Time	
						Run
#6	#6	M-8261	18	25	40-4565-00	2
	#6 Sol	M-8264	18	25	40-4565-00	4
	#8	M-8265	18	25	40-4565-00	2
	#8 Sol	M-8266	18	25	40-4565-00	4
#4	#4	M-8267	18	32	40-4565-00	4
	#6	M-8268	18	32	40-4565-00	2
	#6 Sol	M-8269	18	32	40-4565-00	4
	#8	M-8274	18	32	40-4565-00	4
	#8 Sol	M-8275	18	32	40-4565-00	4
#2	#2	M-8276	18	65	40-4565-00	2
	#4	M-8280	18	45	40-4565-00	4
	#6	M-8281	18	32	40-4565-00	4
	#6 Sol	M-8283	18	32	40-4565-00	4
	#8	M-8284	18	32	40-4565-00	4
	#8 Sol	M-8285	18	32	40-4565-00	4
#1	#2	M-8286	19	65	40-4565-00	4
	#4	M-8287	19	45	40-4565-00	4
	#6	M-8288	19	45	40-4565-00	4
	#6 Sol	M-8291	19	45	40-4565-00	4
	#8	M-8292	19	45	40-4565-00	4
	#8 Sol	M-8293	19	45	40-4565-00	4
1/0	#2	M-8295	19	65	40-4565-00	4
	#4	M-8297	19	65	40-4565-00	4
	#6	M-8299	19	45	40-4565-00	4
	#6 Sol	M-8300	19	45	40-4565-00	4
	#8	M-8301	19	45	40-4565-00	4
2/0	#8 Sol	M-8304	19	45	40-4565-00	4
	#2	M-8306	19	2-45	40-4565-00	4
	#4	M-8307	19	65	40-4565-00	4
	#6	M-8310	19	65	40-4565-00	2
	#6 Sol	M-8311	19	65	40-4565-00	4
	#8	M-8313	19	65	40-4565-00	4
#8 Sol	M-8316	19	65	40-4565-00	4	

- For sizes not listed, contact thermOweld®.
- For expedited service, contact thermOweld®.
- To order weld metal for use with EZ Lite Remote® insert TW before and EZ after weld metal number.
- Required Tools;
  - Handle Clamps w/ Flint Ignitor (see chart for correct handles)
  - 38-0309-00 ~ Flint Ignitor or 38-EZLT-RU EZ Lite Remote®
- Other recommended accessories;
  - 38-3922-00 ~ Mold Cleaning Brush
  - 38-0135-00 ~ Cable Cleaning Brush
  - 38-0330-00 ~ Cable Clamp



# CC-2

## TYPE MOLDS

Horizontal Cable Tap to  
Horizontal Cable Run  
For AWG Conductors

MOLDS FOR AWG CONDUCTORS						
Cable		Mold #	Price Key	Weld Metal	Handle Clamps	Lead Time
Run	Tap					
#2	#2	M-8245	20	45	40-4565-00	2
	#4	M-8246	20	45	40-4565-00	4
#1	#1	M-8247	20	45	40-4565-00	4
	#2	M-8248	20	45	40-4565-00	4
	#4	M-8249	20	45	40-4565-00	4
1/0	#1	M-8250	20	45	40-4565-00	4
	#2	M-8251	20	45	40-4565-00	2
	#4	M-8252	20	45	40-4565-00	4
2/0	#1	M-8253	20	45	40-4565-00	4
	#2	M-8256	20	45	40-4565-00	2
	#4	M-8260	20	45	40-4565-00	2

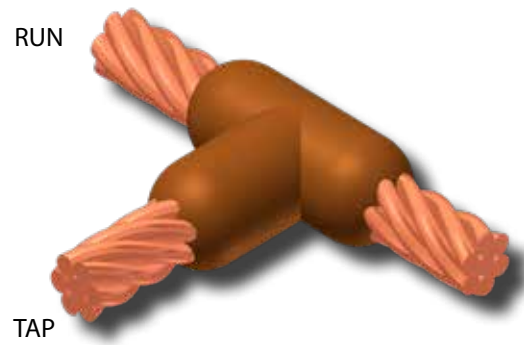

- For sizes not listed, contact thermOweld®.
- Molds listed are for concentric stranded cable. Add suffix "-S" to mold number for solid conductors.
- For expedited service, contact thermOweld®.
- To order weld metal for use with EZ Lite Remote® insert TW before and EZ after weld metal number.
- Required Tools;
  - Handle Clamps w/ Flint Ignitor (see chart for correct handles)
    - 38-0309-00 ~ Flint Ignitor or 38-EZLT-RU EZ Lite Remote®
- Other recommended accessories;
  - 40-0319-01 ~ Mold Cleaner for cartridge sizes #15-#65
  - 40-0319-03 ~ Mold Cleaner for cartridge sizes #90-#500
  - 38-3922-00 ~ Mold Cleaning Brush
  - 38-0135-00 ~ Cable Cleaning Brush
  - 38-0330-00 ~ Cable Clamp

MOLDS FOR AWG CONDUCTORS							
Cable Size	Lug Size	Lug Part #	Mold #	Price Key	Weld Metal	Handle Clamps	Lead Time
#6 Sol†	1/16" x 1/2"	38-4709-00	M-8391-S	18 †	25	40-4565-00	4
#6	1/16" x 1/2"		M-8391	18 †	25	40-4565-00	4
#4 Sol	1/16" x 1/2"		M-8393-S	18 †	25	40-4565-00	4
#4	1/16" x 1/2"		M-8393	18 †	25	40-4565-00	4
#2 Sol	1/16" x 1/2"		M-8395-S	18 †	32	40-4565-00	4
#2	1/16" x 1/2"		M-8395	18 †	32	40-4565-00	4
#1	1/16" x 1/2"		M-8397	18 †	32	40-4565-00	4
1/0	1/16" x 1/2"		M-8398	19 †	45	40-4565-00	4
2/0	1/8" x 1"	38-4200-00	M-8399	19 †	45	40-4565-00	4

† For Wire Size #14 to #10 Solid, 38-0200-00 Sleeve/Weld Req'd

# CB-1

## TYPE MOLDS

Cathodic Protection  
Cable to Lug  
For AWG Conductors

- For sizes not listed, contact thermOweld®.
- Molds listed are for concentric stranded cable. Add suffix "-S" to mold number for solid conductors.
- For expedited service, contact thermOweld®.
- To order weld metal for use with EZ Lite Remote® insert TW before and EZ after weld metal number.
- Required Tools;
  - † ~ Sold complete with handles. If not required, specify MOLD NUMBER followed by suffix "-G".
    - 38-0309-00 ~ Flint Ignitor or 38-EZLT-RU EZ Lite Remote®
- Other recommended accessories;
  - 38-3922-00 ~ Mold Cleaning Brush
  - 38-0135-00 ~ Cable Cleaning Brush

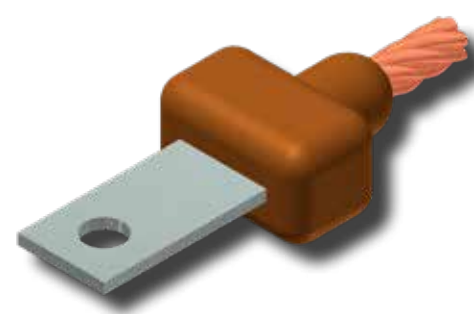

## CR-1 / CR-2

### TYPE MOLDS

#### Horizontal Cable to Ground Rod

#### For AWG Conductors

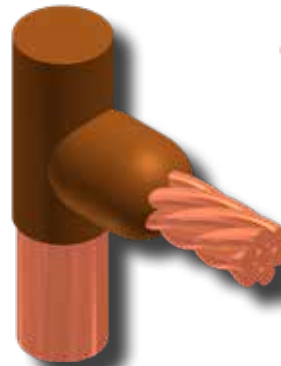

CR-1

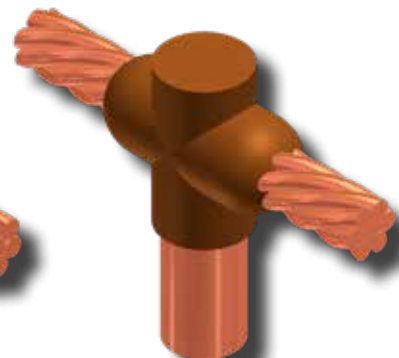

CR-2

MOLDS FOR AWG CONDUCTORS											
Ground Rod Size	Cable Size	CR-1 Molds					CR-2 Molds				
		Mold #	Price Key	Weld Metal	Handle Clamps	Lead Time	Mold #	Price Key	Weld Metal	Handle Clamps	Lead Time
1/2"	#6 Sol†	M-1960-S	18	25	40-4565-00	4	M-1984-S	18	32	40-4565-00	4
	#6	M-1960	18	25	40-4565-00	4	M-1984	18	32	40-4565-00	4
	#4 Sol	M-1961-S	18	25	40-4565-00	4	M-1985-S	18	32	40-4565-00	4
	#4	M-1961	18	25	40-4565-00	4	M-1985	18	32	40-4565-00	4
	#2 Sol	M-1962-S	18	32	40-4565-00	4	M-1986-S	19	45	40-4565-00	4
	#2	M-1962	18	32	40-4565-00	2	M-1986	19	45	40-4565-00	4
	#1	M-1963	19	45	40-4565-00	4	M-1987	19	65	40-4565-00	4
	1/0	M-1964	19	65	40-4565-00	4	M-1988	19	65	40-4565-00	4
	2/0	M-1965	19	65	40-4565-00	4	M-1989	19	65	40-4565-00	4
5/8"	#6 Sol†	M-1968-S	18	32	40-4565-00	2	M-1992-S	19	45	40-4565-00	2
	#6	M-1968	18	32	40-4565-00	2	M-1992	19	45	40-4565-00	2
	#4 Sol	M-1969-S	18	32	40-4565-00	2	M-1993-S	19	65	40-4565-00	4
	#4	M-1969	18	32	40-4565-00	2	M-1993	19	65	40-4565-00	4
	#2 Sol	M-1970-S	19	45	40-4565-00	4	M-1994-S	19	65	40-4565-00	2
	#2	M-1970	19	45	40-4565-00	2	M-1994	19	65	40-4565-00	2
	#1	M-1971	19	45	40-4565-00	4	M-1995	19	65	40-4565-00	4
	1/0	M-1972	19	65	40-4565-00	4	M-1996	20	2-45	40-4565-00	2
	2/0	M-1973	19	65	40-4565-00	2	M-1997	20	2-45	40-4565-00	2
3/4"	#6 Sol†	M-1976-S	18	32	40-4565-00	2	M-2000-S	19	45	40-4565-00	2
	#6	M-1976	18	32	40-4565-00	4	M-2000	19	45	40-4565-00	2
	#4 Sol	M-1977-S	19	45	40-4565-00	2	M-2001-S	19	65	40-4565-00	4
	#4	M-1977	19	45	40-4565-00	2	M-2001	19	65	40-4565-00	4
	#2 Sol	M-1978-S	19	45	40-4565-00	4	M-2002-S	19	65	40-4565-00	4
	#2	M-1978	19	45	40-4565-00	4	M-2002	19	65	40-4565-00	2
	#1	M-1979	19	45	40-4565-00	4	M-2003	19	65	40-4565-00	4
	1/0	M-1980	19	65	40-4565-00	4	M-2004	20	2-45	40-4565-00	2
	2/0	M-1981	19	65	40-4565-00	2	M-2005	20	2-45	40-4565-00	2

† For wire size #14 to #10 Solid, order (1) 38-0200-00 Sleeve for CR-1 Type Molds or (2) 38-0200-00 Sleeves for CR-2 Type Molds

- For sizes not listed, contact thermOweld®.
- Molds listed are for copper clad ground rods. For welding to steel, stainless steel or galvanized steel ground rods add suffix "-N" to mold number.
- For expedited service, contact thermOweld®
- To order weld metal for use with EZ Lite Remote® insert TW before and EZ after weld metal number.
- Required Tools;
  - Handle Clamps w/ Flint Ignitor (see chart for correct handles) 38-0309-00 ~ Flint Ignitor or 38-EZLT-RU EZ Lite Remote®
- Other recommended accessories;
  - 38-3922-00 ~ Mold Cleaning Brush
  - 38-0135-00 ~ Cable Cleaning Brush
  - 38-0304-00 ~ File
  - 38-0330-00 ~ Cable Clamp

#### NOTES

1. .475" actual diameter. For full 1/2" (.500) ground rod and roll-threaded rod, add suffix "-N" to mold number, i.e. M-1965-N is full 1/2" diameter ground rod or roll-threaded rod to 2/0 Str cable.
2. .563" actual diameter. For full 5/8" (.625) ground rod and roll-threaded rod, add suffix "-N" to mold number, i.e. M-1973-N is full 5/8" diameter ground rod or roll-threaded rod to 2/0 Str cable.
3. .682" actual diameter. For full 3/4" (.750) ground rod and roll-threaded rod, add suffix "-N" to mold number, i.e. M-1981-N is full 3/4" diameter ground rod or roll-threaded rod to 2/0 Str. cable.

# TROUBLE SHOOTING TIPS

Problem	Probable Cause	Correction To Make
Insufficient metal to make weld.	Worn mold resulting in leaking weld metal.	Replace mold or if only worn around conductor opening, use duct seal around conductor. Do not get duct seal into mold cavity.
	Wrong size cartridge for mold.	Check ID plate for mold and compare with number on bottom of cartridge.
	Too much spillage when dumping powder.	Carefully open lid while holding over crucible and dump.
	Wrong mold for conductor being used.	Replace with correct mold. In some applications, shim stock or adapter sleeves can be used to enlarge cable to fit mold.
Mold does not close tightly causing weld metal to leak out.	Handle clamps not properly adjusted.	Remove set screw between the handles of the mold and adjust handle tension by backing out the eye bolt.
	Dirt or slag stuck in parting line of mold.	Clean mold thoroughly between connections.
	Bent or out-of-round cable.	Straighten or cut out bad section of cable.
Handle clamps will not lock closed.	Handle clamps not properly adjusted.	Remove set screw between the handles of the mold and adjust handle tension by backing out the eye bolt.
Excessively high weld, bubbly or gassy appearance, poor weld.	Moisture in mold.	Pre-heat mold to above 220° F with a propane torch.
	Oil, grease, moisture or foreign material on conductors.	Pre-heat conductors with propane torch then use a clean wire brush on conductor to remove any residue left on conductors. If welding to cast iron or steel surface, weld area must be cleaned down to bright metal.
	Wrong size cartridge for mold. See	Check ID plate for mold and compare with number on bottom of cartridge.
	Duct seal in weld cavity.	Take special precautions to keep duct seal out of weld cavity.
	Weld powder has gotten wet.	Replace with fresh, dry weld powder.
Weld metal blows out top of mold.	Mold worn or chipped around disc seal allowing powder to leak into mold cavity.	Replace mold.
	Forgot to use steel disc or did not seat it properly at bottom of crucible.	Make sure disc is seated at bottom of crucible before pouring the powder into crucible.

Continued on next page

## TROUBLE SHOOTING TIPS

Problem	Probable Cause	Correction To Make
Cannot ignite powder.	Insufficient starting powder in ignition pocket on mold lid.	Place at least half of starting powder in ignition pocket of mold lid.
	Flint ignitor not shooting enough spark.	Clean flint ignitor according to directions on box or replace flint ignitor.
	Starting powder lumped together.	Break up starting powder on lid with edge of powder tube.
Mold wearing out too fast.	Improper cleaning of mold.	Use mold cleaner, soft natural bristle brush or clean rag to clean mold between shots. Do not use wire brush or screwdriver on molds.
	Bent or out of round cable causes chipping and premature wear of the mold.	Use caution when closing mold. Do not force mold shut around bent, twisted or out of round conductors.
Poor weld to ground rod.	Weight of mold not supported during reaction causing mold to slip when cable melts.	Use locking pliers on ground rod under mold to support the weight of the mold during the reaction.
	Moisture or contaminant on cable or ground rod.	Pre-heat conductors with propane torch then use a clean wire brush on conductors to remove any residue left on conductors.
Weld will not stick to steel surface.	Improperly cleaned area on steel.	An area larger than the weld area should be cleaned down to bright clean metal.
	Moisture or contaminant on cable or steel surface.	Pre-heat conductors with propane torch then use a clean wire brush on conductors to remove any residue left on conductors.
	Cable is improperly positioned in mold, blocking the flow of weld metal.	Position cable in mold in accordance with directions for mold. If directions are not available, position top of cable in the center of where the liquid weld metal hits the steel.
Weld will not stick to cast iron surface.	All of the causes listed under welding to steel surface also apply to this section.	
	Not using CI (Cast Iron) powder.	Specify "CI" behind cartridge when order powder (i.e. 25 CI).
Cable pulls out of mold when it is fired.	Cables are either twisted or under tension.	Use 38-0330-00 cable clamp or other method to remove tension. Cut out severely twisted cable.

## TROUBLE SHOOTING TIPS for the EZ Lite Remote® Ignition System

USE A FLINT IGNITOR OR THE EZ Lite Remote® AND NEVER BE STUCK OUT ON THE JOB

Problem	Probable Cause	Correction To Make
Weld metal does not ignite.	Batteries need to be replaced.	Check the battery level indicator; if yellow or red replace with 4 D alkaline batteries.
Ignitor does not ignite.	Ignitor not inserted in the connector properly.	Make sure the ignitor is inserted such that it snaps in the connector.
	Batteries need to be replaced.	Check battery level indicator; if yellow or red replace with 4 D alkaline batteries.
	Ignitor could be used or damaged.	Replace with a new ignitor.
	Cord damaged by improper storage	Replace unit
Battery level indicator does not function.	Batteries need to be replaced.	Replace with 4 D size alkaline batteries.
	Batteries inserted incorrectly.	Check direction at the back of the remote unit to insert the batteries.
	Incorrect battery type.	Make sure D size alkaline batteries are used.
	Blown fuse.	Replace fuse with GMA-6A Cooper Bussmann or equivalent.
	Cold weather has effected the batteries.	Use our Cold Weather kit, or keep EZ Lite Remote warm.

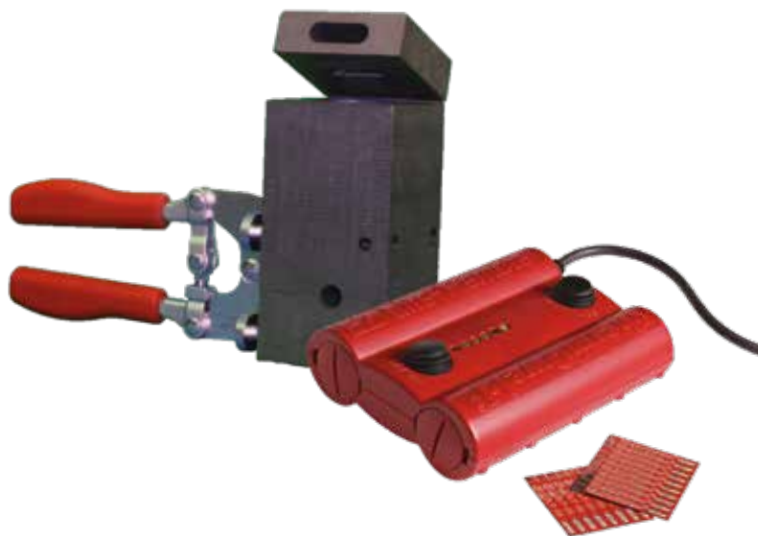

NOTES

Lined area for notes.

Lined area for notes with horizontal ruling lines.

# thermOweld<sup>®</sup>

## Cathodic Protection Catalog

1140 North 129th East Ave.  
Tulsa, Oklahoma 74116  
+1-918-627-5210

[www.thermoweld.com](http://www.thermoweld.com) | 800-558-1373



0000-99-1064-00 01-18



The Contractors Choice

1-800-558-1373 or FAX 1-800-788-1668 • Visit [www.conind.com](http://www.conind.com)

