

SR2B121JD

compact smart relay Zelio Logic - 12 I O - 24 V
DC - clock - display

Product availability : Stock - Normally stocked in distribution facility

Price* : 282.00 USD



Main

Range of product	Zelio Logic
Product or component type	Compact smart relay

Complementary

Local display	With
Number of control scheme lines	0...500 with FBD programming 0...240 with ladder programming
Cycle time	6...90 ms
Backup time	10 years at 77 °F (25 °C)
Clock drift	6 s/month at 77 °F (25 °C) 12 min/year at 32...131 °F (0...55 °C)
Checks	Program memory on each power up
[Us] rated supply voltage	12 V DC
Supply voltage limits	10.4...14.4 V
Supply current	120 mA (without extension)
Power dissipation in W	1.5 W without extension
Reverse polarity protection	With
Discrete input number	8 conforming to EN/IEC 61131-2 type 1
Discrete input type	Resistive
Discrete input voltage	12 V DC
Discrete input current	4 mA
Counting frequency	1 kHz for discrete input
Voltage state 1 guaranteed	>= 7 V for IB...IG used as discrete input circuit >= 5.6 V for I1...IA and IH...IR discrete input circuit
Voltage state 0 guaranteed	<= 3 V for IB...IG used as discrete input circuit <= 2.4 V for I1...IA and IH...IR discrete input circuit
Current state 1 guaranteed	>= 2 mA for I1...IA and IH...IR discrete input circuit

	>= 0.5 mA for IB...IG used as discrete input circuit
Current state 0 guaranteed	<= 0.2 mA for IB...IG used as discrete input circuit <= 0.9 mA for I1...IA and IH...IR discrete input circuit
Input compatibility	3-wire proximity sensors PNP (discrete input)
Analogue input number	4
Analogue input type	Common mode
Analogue input range	0...12 V 0...10 V
Maximum permissible voltage	14.4 V (analogue input circuit)
Analogue input resolution	8 bits at maximum voltage
LSB value	39 mV (analogue input circuit)
Conversion time	Smart relay cycle time analogue input circuit
Conversion error	+/- 5 %at 77 °F (25 °C)for analogue input circuit +/- 6.2 %at 131 °F (55 °C)for analogue input circuit
Repeat accuracy	+/- 2 %at 131 °F (55 °C)for analogue input circuit
Operating distance	10 m between stations, with screened cable (sensor not isolated) analogue input circuit
Input impedance	14 kOhm (IB...IG used as analogue input circuit) 14 kOhm (IB...IG used as discrete input circuit) 2.7 kOhm (I1...IA and IH...IR discrete input circuit)
Number of outputs	4 relay output(s)
Output voltage limits	24...250 V AC (relay output) 5...30 V DC (relay output)
Contacts type and composition	NO relay output
Output thermal current	8 A for all 4 outputs (relay output)
Electrical durability	500000 cycles AC-12at 230 V, 1.5 Afor relay output conforming to EN/IEC 60947-5-1 500000 cycles AC-15at 230 V, 0.9 Afor relay output conforming to EN/IEC 60947-5-1 500000 cycles DC-12at 24 V, 1.5 Afor relay output conforming to EN/IEC 60947-5-1 500000 cycles DC-13at 24 V, 0.6 Afor relay output conforming to EN/IEC 60947-5-1
Switching capacity in mA	>= 10 mAat 12 V (relay output)
Operating rate in Hz	0.1 Hz (at Ie)for relay output 10 Hz (no load)for relay output
Mechanical durability	10000000 cycles (relay output)
[Uimp] rated impulse withstand voltage	4 kV conforming to EN/IEC 60947-1 and EN/IEC 60664-1
Clock	With
Response time	10 ms (from state 0 to state 1) relay output 5 ms (from state 1 to state 0) relay output
Connections - terminals	Screw terminals, clamping capacity: 1 x 0.2...1 x 2.5 mm ² AWG 25...AWG 14 semi-solid Screw terminals, clamping capacity: 1 x 0.2...1 x 2.5 mm ² AWG 25...AWG 14 solid Screw terminals, clamping capacity: 1 x 0.25...1 x 2.5 mm ² AWG 24...AWG 14 flexible with cable end Screw terminals, clamping capacity: 2 x 0.2...2 x 1.5 mm ² AWG 24...AWG 16 solid Screw terminals, clamping capacity: 2 x 0.25...2 x 0.75 mm ² AWG 24...AWG 18 flexible with cable end
Tightening torque	4.42 lbf.in (0.5 N.m)
Overvoltage category	III conforming to EN/IEC 60664-1
Product weight	0.55 lb(US) (0.25 kg)

Environment

Immunity to microbreaks	<= 1 ms repeated 20 times
Product certifications	UL CSA C-Tick GL GOST
Standards	EN/IEC 61000-4-11 EN/IEC 61000-4-5 EN/IEC 61000-4-6 level 3 EN/IEC 61000-4-2 level 3 EN/IEC 61000-4-3 EN/IEC 60068-2-6 Fc EN/IEC 61000-4-12 EN/IEC 61000-4-4 level 3

EN/IEC 60068-2-27 Ea

IP degree of protection	IP20 (terminal block) conforming to IEC 60529 IP40 (front panel) conforming to IEC 60529
Environmental characteristic	EMC directive conforming to EN/IEC 61000-6-2 EMC directive conforming to EN/IEC 61000-6-3 EMC directive conforming to EN/IEC 61000-6-4 EMC directive conforming to EN/IEC 61131-2 zone B Low voltage directive conforming to EN/IEC 61131-2
Disturbance radiated/conducted	Class B conforming to EN 55022-11 group 1
Pollution degree	2 conforming to EN/IEC 61131-2
Ambient air temperature for operation	-4...104 °F (-20...40 °C) in non-ventilated enclosure conforming to IEC 60068-2-1 and IEC 60068-2-2 -4...131 °F (-20...55 °C) conforming to IEC 60068-2-1 and IEC 60068-2-2
Ambient air temperature for storage	-40...158 °F (-40...70 °C)
Operating altitude	6561.68 ft (2000 m)
Altitude transport	<= 10000 ft (3048 m)
Relative humidity	95 % without condensation or dripping water

Ordering and shipping details

Category	22378 - SR2,3 ZELIO 2 RELAYS
Discount Schedule	I
GTIN	00785901422525
Nbr. of units in pkg.	1
Package weight(Lbs)	0.5300000000000003
Returnability	Y
Country of origin	FR

Contractual warranty

Warranty period	18 months
-----------------	-----------

Compact and Modular Smart Relays

Mounting on 35 mm/1.38 in. DIN Rail

(1) With SR2USB01 or SR2BTC01

Screw Fixing (Retractable Lugs)

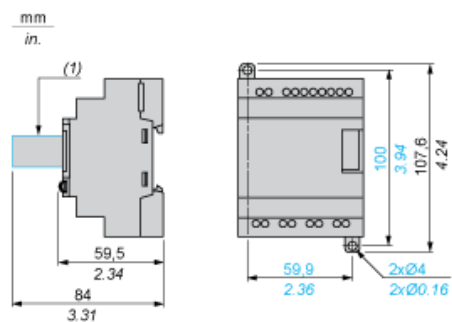

(1) With SR2USB01 or SR2BTC01

Position of Display

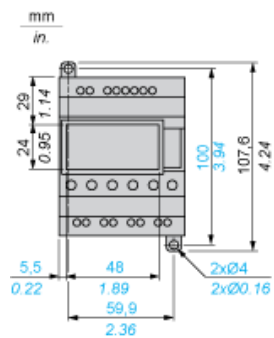

Compact and Modular Smart Relays

Connection of Smart Relays on DC Supply

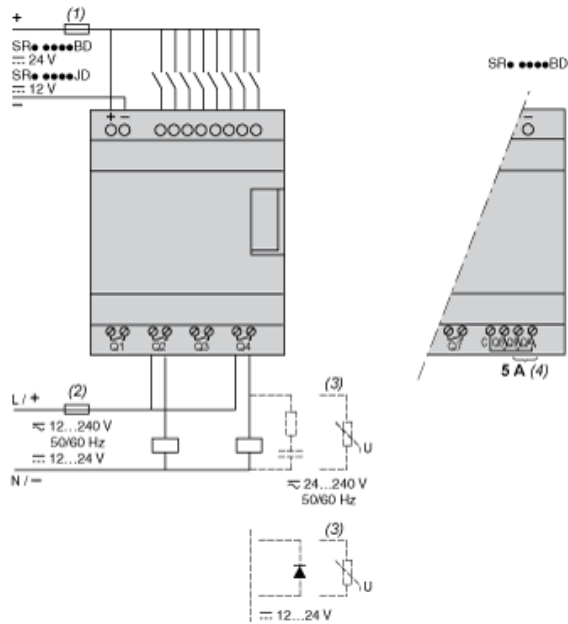

- (1) 1 A quick-blow fuse or circuit-breaker.
- (2) Fuse or circuit-breaker.
- (3) Inductive load.
- (4) Q9 and QA: 5 A (max. current in terminal C: 10 A).

Discrete Input Used for 3-Wire Sensors

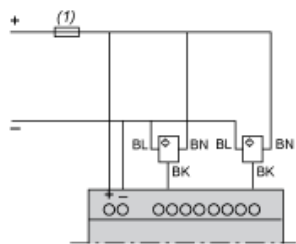

- (1) 1 A quick-blow fuse or circuit-breaker.

Compact and Modular Smart Relays

Electrical Durability of Relay Outputs

(in millions of operating cycles, conforming to IEC/EN 60947-5-1)

DC-12 (1)

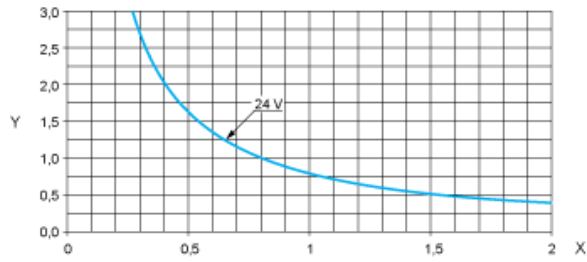

X: Current (A)

Y: Millions of operating cycles

(1) DC-12: control of resistive loads and of solid state loads isolated by opto-coupler, $L/R \leq 1$ ms.

DC-13 (1)

X: Current (A)

Y: Millions of operating cycles

(1) DC-13: switching electromagnets, $L/R \leq 2 \times (U_e \times I_e)$ in ms, U_e : rated operational voltage, I_e : rated operational current (with a protection diode on the load,