

TeSys U Motor management system

Type of product	Range	Pages
TeSys U Motor controller		C1/2
Current transformers for TeSys U motor controller	From 30 to 800 A	C1/2
Type 2 coordination table for assemblies of: <ul style="list-style-type: none"> ■ circuit breaker + contactor + TeSys U controller + current transformer ■ fuses + contactor + TeSys U controller + current transformer 	C1/3	

Motor management devices

TeSys T Motor management system

Controllers with Modbus, or CANopen, Devicenet, Profibus, Ethernet TCP/IP communication port		C1/4
Extension modules		C1/5
HMI terminal and cables		C1/5
Accessories		C1/6

Technical Data for Designers

C1/13

TeSys

TeSys U Motor management controller

Product references

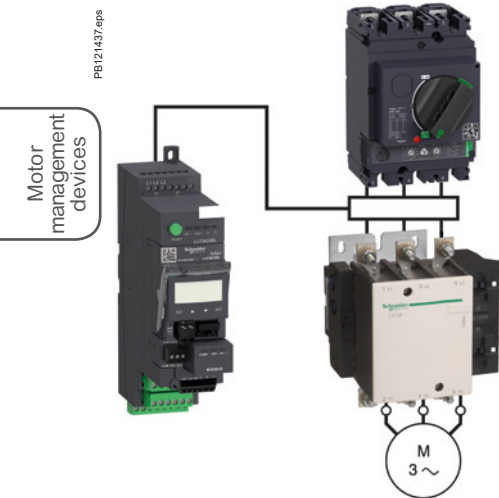

LUTM + LUCMT1BL + LUTC●●



LUTM10BL



LUCMT1BL

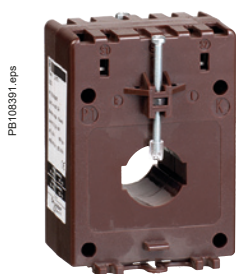

LUTC●●●●

References

Control bases (auxiliary supply voltage \approx 24 V)

Connection	Control	For use with contactor	Reference	Weight kg
Screws	Screws	LC1D●●	LUTM10BL	0.800
		LC1F●●●	LUTM20BL	0.800

Control units

Description	Class	For motor type	Setting range	Reference	Weight kg
Advanced	10	3-phase	0.35...1.05	LUCBT1BL	0.140
	20	3-phase	0.35...1.05	LUCDT1BL	0.140
Multifunction	5 to 30	3-phase	0.35...1.05	LUCMT1BL	0.175

Current transformers

Operating current		Reference	Weight kg
Primary	Secondary		
30	1	LUTC0301	0.550
50	1	LUTC0501	0.330
100	1	LUTC1001	0.450
200	1	LUTC2001	0.590
400	1	LUTC4001	0.870
800	1	LUTC8001	1.210

Function modules and communication modules

The TeSys U controller is compatible with the modules listed below:

- Thermal overload alarm module LUFW10,
- Motor load indication module LUFV2,
- Communication modules:
 - Modbus (LULC033),
 - CANopen (LULC08),
 - DeviceNet (LULC09),
 - Advantys STB (LULC15).

Note: Communication modules **LULC07** (Profibus DP), **ASILUFC5** and **ASILUFC51** (AS-Interface) are not compatible with the TeSys U controller. Module **LUFW10** is only compatible with control units **LUCBT1BL** and **LUCDT1BL**.

Combinations providing type 2 coordination

With Circuit breaker

Standard power ratings of 3-phase motors 50-60 Hz in category AC-3 400/415 V		Circuit breaker			Contactor	TeSys U controller	Current transformers
PkW	IeA	Reference	Rating A	I _{rm} ⁽¹⁾ A	Reference ⁽²⁾	Reference	Reference
18.5	35	GV3L40	40	560	LC1D50A	LUTM + LUC●	3 x LUTC0501
22	41	GV3L50	50	700	LC1D50A	LUTM + LUC●	3 x LUTC1001
30	55	GV3L65	65	910	LC1D65A	LUTM + LUC●	3 x LUTC1001
37	66	GV4L80	80	1040	LC1D80	LUTM + LUC●	3 x LUTC1001
45	80	NSX100HMA	100	1300	LC1D95	LUTM + LUC●	3 x LUTC1001
55	97	NSX160HMA	150	1350	LC1D115	LUTM + LUC●	3 x LUTC2001
75	132	NSX160HMA	150	1800	LC1D150	LUTM + LUC●	3 x LUTC2001
90	160	NSX250HMA	220	2200	LC1F185	LUTM + LUC●	3 x LUTC2001
110	195	NSX250HMA	220	2640	LC1F225	LUTM + LUC●	3 x LUTC4001
132	230	NSX400HMA	320	3200	LC1F265	LUTM + LUC●	3 x LUTC4001
160	280	NSX400HMA	320	4160	LC1F330	LUTM + LUC●	3 x LUTC4001
200	350	NSX630HMA	500	5000	LC1F400	LUTM + LUC●	3 x LUTC4001
220	385	NSX630HMA	500	5500	LC1F400	LUTM + LUC●	3 x LUTC4001
250	430	NSX630HMA	500	6000	LC1F500	LUTM + LUC●	3 x LUTC8001

With fuses

Standard power ratings of 3-phase motors 50-60 Hz in category AC-3 400/415 V		Switch-disconnector fuse	aM fuses		Contactor	TeSys U controller	Current transformers
PkW	IeA	Reference	Size	Rating A	Reference ⁽²⁾	Reference	Reference
18.5	35	GS●F	14 x 51	40	LC1D40A	LUTM + LUC●	3 x LUTC0501
22	41	GS●J	22 x 58	50	LC1D50A	LUTM + LUC●	3 x LUTC1001
30	55	GS●J	22 x 58	80	LC1D80	LUTM + LUC●	3 x LUTC1001
37	66	GS●J	22 x 58	100	LC1D80	LUTM + LUC●	3 x LUTC1001
45	80	GS●J	22 x 58	100	LC1D95	LUTM + LUC●	3 x LUTC1001
55	97	GS●L	T0	125	LC1D115	LUTM + LUC●	3 x LUTC2001
75	132	GS●L	T0	160	LC1D150	LUTM + LUC●	3 x LUTC2001
90	160	GS●N	T1	200	LC1F185	LUTM + LUC●	3 x LUTC2001
110	195	GS●N	T1	250	LC1F225	LUTM + LUC●	3 x LUTC4001
132	230	GS●QQ	T2	315	LC1F265	LUTM + LUC●	3 x LUTC4001
160	280	GS●QQ	T2	400	LC1F330	LUTM + LUC●	3 x LUTC4001
200	350	GS2S	T3	500	LC1F400	LUTM + LUC●	3 x LUTC4001
220	385	GS2S	T3	500	LC1F400	LUTM + LUC●	3 x LUTC4001
250	430	GS2S	T3	500	LC1F500	LUTM + LUC●	3 x LUTC8001
315	540	GS2S	T3	630	LC1F630	LUTM + LUC●	3 x LUTC8001

(1) I_{rm}: setting current of the magnetic trip.

(2) For reversing operation, replace the prefix LC1 with LC2.



TeSys

TeSys T Motor management system

Product references

Motor management devices



PB121434.eps

LTMRO8MBD



PB121440.eps

LTMRO8CBD



PB121441.eps

LTMRO8DBD



PB121442.eps

LTMRO8PBD



PB121443.eps

LTMRO8EBD

Controllers

Setting range	Control voltage	Current range	Reference
---------------	-----------------	---------------	-----------

A	V	A	
---	---	---	--

For Modbus

8	24	0.4...8	LTMRO8MBD
	~ 100...240	0.4...8	LTMRO8MFM
27	24	1.35...27	LTMRO27MBD
	~ 100...240	1.35...27	LTMRO27MFM
100	24	5...100	LTMRO100MBD
	~ 100...240	5...100	LTMRO100MFM

For CANopen

8	24	0.4...8	LTMRO8CBD
	~ 100...240	0.4...8	LTMRO8CFM
27	24	1.35...27	LTMRO27CBD
	~ 100...240	1.35...27	LTMRO27CFM
100	24	5...100	LTMRO100CBD
	~ 100...240	5...100	LTMRO100CFM

For DeviceNet

8	24	0.4...8	LTMRO8DBD
	~ 100...240	0.4...8	LTMRO8DFM
27	24	1.35...27	LTMRO27DBD
	~ 100...240	1.35...27	LTMRO27DFM
100	24	5...100	LTMRO100DBD
	~ 100...240	5...100	LTMRO100DFM

For Profibus DP

8	24	0.4...8	LTMRO8PBD
	~ 100...240	0.4...8	LTMRO8PFM
27	24	1.35...27	LTMRO27PBD
	~ 100...240	1.35...27	LTMRO27PFM
100	24	5...100	LTMRO100PBD
	~ 100...240	5...100	LTMRO100PFM

For Ethernet TCP/IP (communication protocols: Modbus/TCP and EtherNet/IP)

8	24	0.4...8	LTMRO8EBD
	~ 100...240	0.4...8	LTMRO8EFM
27	24	1.35...27	LTMRO27EBD
	~ 100...240	1.35...27	LTMRO27EFM
100	24	5...100	LTMRO100EBD
	~ 100...240	5...100	LTMRO100EFM

Filter

Control voltage	Current max	Reference
V	mA	
~ 150...240	130	LTM9F

TeSys

TeSys T Motor management system

Product references



LTMEV40BD



LTMCC004



LTMCUF

Extension modules (with voltage measurement on the 3 phases)

Input control voltage	Number of inputs	Supply to the electronics	Reference
⎓ 24	4	Via the controller	LTMEV40BD
~ 100...240	4	Via the controller	LTMEV40FM

HMI terminals

Description	Supply Voltage	Reference
Operator control unit	Languages: English French Spanish Supply via the controller	LTMCU
Operator control unit with Fast Device Replacement Service (FDR)	Languages: English French Spanish Supply via the controller	LTMCUF
Kit for portable LTM CU		LTM9KCU
Magelis compact display.	⎓ 24 V external	XBTN410

Description	Number and type of connectors	Length m	Reference
Connecting cables for the LTM CU control unit	2 x RJ45	1	LTM9CU10
		3	LTM9CU30
Connecting cables for the XBT N410	SUB-D 25-way female RJ45	2.5	XBTZ938

Cables

Description	Number and type of connectors	Length m	Reference
Connecting cables For connecting the controller to the extension module	2 x RJ45	0.04	LTMCC004⁽¹⁾
		0.3	LTM9CEXP03
		1	LTM9CEXP10

Replacement connectors

Description	Number and type of connectors	Reference
Complete set of connectors for controllers and extension modules	10 screw terminals (all network versions included)	LTM9TCS
Connector extraction tool		LTM9TCT⁽²⁾

⁽¹⁾ Sold in lots of 6.

⁽²⁾ Sold in packs of 3.

Motor management devices



TeSys

TeSys T Motor management system

Product references

Motor
management
devices

PF526393.eps



LT6CT4001



PB121445.eps



DA1TT000

Configuration tools

Description	Composition	Reference	Weight kg
Connection cable for PC	USB to RJ45 cable, length 2.5 m	TCSMCNAM3M002P	0.200

Current transformers ⁽¹⁾

Operational current		Reference	Weight kg
Primary A	Secondary A		
100	1 ⁽²⁾	LT6CT1001	0.550
200	1 ⁽²⁾	LT6CT2001	0.550
400	1 ⁽²⁾	LT6CT4001	0.550
800	1 ⁽²⁾	LT6CT8001	0.680

Earth fault toroids (marketed under the Schneider Electric brand)

Rated operational current I _e A	Internal Ø of toroid mm	Reference	Weight kg
Closed toroids, type A			
65	30	50437	0.120
85	50	50438	0.200
160	80	50439	0.420
250	120	50440	0.530
400	200	50441	1.320
630	300	50442	2.230

Split toroids, type OA

85	46	50485	1.300
250	110	50486	3.200

PTC thermistor probes ⁽³⁾

Description	Nominal Operating Temperature (NOT) °C	Colour	Unit reference ⁽⁴⁾
Triple probes	90	Green/green	DA1TT090
	110	Brown/brown	DA1TT110
	120	Grey/grey	DA1TT120
	130	Blue/blue	DA1TT130
	140	White/blue	DA1TT140
	150	Black/black	DA1TT150
	160	Blue/red	DA1TT160
	170	White/green	DA1TT170

⁽¹⁾ The transformers offered for use with TeSys U starters are suitable.
Please consult our "TeSys U starter-controllers" catalogue.

⁽²⁾ For use with LTM0800 controllers.

⁽³⁾ PTC: Positive Temperature Coefficient.

⁽⁴⁾ Sold in lots of 10.

Marking accessories (to be ordered separately)

Description	Composition	Height mm	Unit reference	Weight kg
Clip-in markers	Strips of 10 identical numbers (0 to 9) or capital letters (A to Z)	5	NSYTRABF5● ⁽¹⁾	0.002
		6	NSYTRABF6● ⁽¹⁾	0.002

Connection accessories

Description	Length m	Reference	Weight kg
For Modbus connection			
Cables fitted with 2 x RJ45 connectors	0.3	VW3A8306R03	0.045
	1	VW3A8306R10	0.065
	3	VW3A8306R30	0.125
T-junctions	0.3	VW3A8306TF03	0.032
	1	VW3A8306TF10	0.032
RS 485 line terminator	–	VW3A8306R	0.012

For CANopen connection

Cables	50	TSXCANCA50	4.930	
	100	TSXCANCA100	8.800	
	300	TSXCANCA300	24.560	
IP20 connectors	Elbowed (90°)	–	TSXCANKCDF90T	0.046
SUB-D 9-way female	Straight	–	TSXCANKCDF180T	0.049
Line end adapter switch	Elbowed (90°) with SUB-D 9-way connector for connection to PC or diagnostic tool	–	TSXCANKCDF90TP	0.051

For DeviceNet connection

Cables	50	TSXCANCA50	4.930
	100	TSXCANCA100	8.800
	300	TSXCANCA300	24.560

For Profibus DP connection⁽²⁾

Cables	100	TSXPBSCA100	–	
	400	TSXPBSCA400	–	
Connectors	With line terminator	–	490NAD91103	–
	Without line terminator	–	490NAD91104	–
	With line terminator and terminal port	–	490NAD91105	–

For Ethernet TCP/IP connection

Shielded twisted pair cables to standard EIA/TIA568

Cables fitted with 2 x RJ45 connectors for connection to terminal equipment	Straight	2	490NTW00002	–
		5	490NTW00005	–
		12	490NTW00012	–
		40	490NTW00040	–
		80	490NTW00080	–

Shielded twisted pair cables, UL and CSA 22.1 approved

Cables fitted with 2 x RJ45 connectors for connection to terminal equipment	Straight	2	490NTW00002U	–
		5	490NTW00005U	–
		12	490NTW00012U	–
		40	490NTW00040U	–
		80	490NTW00080U	–
Ethernet Connector	Elbowed 180°		LTM9CE180T ⁽³⁾	0.180

⁽¹⁾ When ordering, replace the ● in the reference with the number or letter required.

⁽²⁾ To order other connectors and cables (UL cables for harsh environments, etc.), please consult our Customer Care Centre.

⁽³⁾ Sold in packs of 6.

TeSys

TeSys T Motor management system

Product references

Motor management devices



0.37 to 355 kW at 400/415 V: type 2 coordination							
With switch-disconnector, contactor and class 10 controller							
Standard power ratings of 3-phase motors 50/60 Hz in category AC-3 400/415 V		Switch-disconnector	aM fuses		Contactor	TeSys T controller	External current transformer
P	I _e	Reference ⁽¹⁾	Size	Rating	Reference ⁽²⁾	Reference	Reference
kW	A			A			
0.37	1.1	GS1DD	10 x 38	2	LC1D09	LTMR08●●	–
0.55	1.5	GS1DD	10 x 38	2	LC1D09	LTMR08●●	–
0.75	1.9	GS1DD	10 x 38	4	LC1D09	LTMR08●●	–
1.1	2.7	GS1DD	10 x 38	4	LC1D09	LTMR08●●	–
1.5	3.6	GS1DD	10 x 38	4	LC1D09	LTMR08●●	–
2.2	4.9	GS1DD	10 x 38	6	LC1D09	LTMR08●●	–
3	6.5	GS1DD	10 x 38	8	LC1D09	LTMR27●●	–
4	8.5	GS1DD	10 x 38	10	LC1D09	LTMR27●●	–
5.5	11.5	GS1DD	10 x 38	16	LC1D12	LTMR27●●	–
7.5	15.5	GS1DD	10 x 38	16	LC1D25	LTMR27●●	–
10	19	GS●F	14 x 51	25	LC1D25	LTMR27●●	–
11	22	GS●F	14 x 51	25	LC1D25	LTMR27●●	–
15	29	GS●F	14 x 51	32	LC1D32	LTMR100●●	–
18.5	35	GS●F	14 x 51	40	LC1D40A	LTMR100●●	–
22	41	GS●J	22 x 58	50	LC1D50A	LTMR100●●	–
30	55	GS●J	22 x 58	80	LC1D65A	LTMR100●●	–
37	66	GS●J	22 x 58	100	LC1D80	LTMR100●●	–
45	80	GS●J	22 x 58	100	LC1D95	LTMR100●●	–
55	97	GS●K	T00	125	LC1D115	LTMR08●●	LT6CT2001
75	132	GS●L	T0	160	LC1D150	LTMR08●●	LT6CT2001
90	160	GS●N	T1	200	LC1F185	LTMR08●●	LT6CT2001
110	195	GS●N	T1	250	LC1F225	LTMR08●●	LT6CT4001
132	230	GS●QQ	T2	315	LC1F265	LTMR08●●	LT6CT4001
160	280	GS●QQ	T2	355	LC1F400	LTMR08●●	LT6CT4001
200	350	GS2S	T3	500	LC1F400	LTMR08●●	LT6CT8001
250	430	GS2S	T3	500	LC1F500	LTMR08●●	LT6CT8001
315	540	GS2S	T3	630	LC1F630	LTMR08●●	LT6CT8001
355	610	GS2V	T4	800	LC1F630	LTMR08●●	LT6CT8001

(1) GS●: GS1 for direct operator, GS2 for external operator.

(2) For reversing operation, replace the prefix LC1 with LC2.

TeSys

TeSys T Motor management system

Product references

0.06 to 250 kW at 400/415 V: type 2 coordination

With Circuit breaker, contactor and class 10 controller

Standard power ratings of 3-phase motors 50/60 Hz in category AC-3 400/415 V			Circuit breaker	Contactor	TeSys T controller	External current transformer
P	I _e	I _{cc}	Reference	Reference	Reference	Reference
kW	A	kA				
0.06	0.2	130	GV2L03	LC1D09	LTMR08●●	–
0.09	0.3	130	GV2L03	LC1D09	LTMR08●●	–
0.12	0.44	130	GV2L04	LC1D09	LTMR08●●	–
0.18	0.6	130	GV2L04	LC1D09	LTMR08●●	–
0.25	0.85	130	GV2L05	LC1D09	LTMR08●●	–
0.37	1.1	130	GV2L05	LC1D09	LTMR08●●	–
0.55	1.5	130	GV2L06	LC1D09	LTMR08●●	–
0.75	1.9	130	GV2L07	LC1D09	LTMR08●●	–
1.1	2.7	130	GV2L07	LC1D18	LTMR08●●	–
1.5	3.6	130	GV2L08	LC1D18	LTMR08●●	–
2.2	4.9	130	GV2L10	LC1D18	LTMR08●●	–
3	6.5	130	GV2L14	LC1D18	LTMR08●●	–
4	8.5	130	GV2L14	LC1D18	LTMR27●●	–
5.5	11.5	130	GV2L16	LC1D25	LTMR27●●	–
7.5	15.5	50	GV2L20	LC1D25	LTMR27●●	–
9	18.1	50	GV2L22	LC1D25	LTMR27●●	–
11	22	50	GV2L22	LC1D25	LTMR27●●	–
15	29	50	GV3L32	LC1D40A	LTMR100●●	–
18.5	35	50	GV3L40	LC1D50A	LTMR100●●	–
22	41	50	GV3L50	LC1D50A	LTMR100●●	–
30	55	50	GV3L65	LC1D65A	LTMR100●●	–
37	66	70	GV4LE80S	LC1D80	LTMR100●●	–
45	80	70	NSX100HMA	LC1D115	LTMR100●●	–

Motor management devices



TeSys

TeSys T Motor management system

Product references

Motor management devices



0.06 to 250 kW at 400/415 V: type 2 coordination						
With circuit breaker, contactor and class 10 controller						
Standard power ratings of 3-phase motors 50/60 Hz in category AC-3 400/415 V			Circuit breaker	Contactor	TeSys T controller	External current transformer
P kW	I _e A	I _{cc} kA	Reference	Reference	Reference	Reference
55	97	50	NSX160NMA	LC1D115	LTMR08●●	LT6CT2001
55	97	70	NSX160HMA	LC1D115	LTMR08●●	LT6CT2001
75	132	50	NSX160NMA	LC1D150	LTMR08●●	LT6CT2001
75	132	70	NSX160HMA	LC1D150	LTMR08●●	LT6CT2001
90	160	50	NSX250NMA	LC1F185	LTMR08●●	LT6CT2001
90	160	70	NSX250HMA	LC1F185	LTMR08●●	LT6CT2001
110	195	50	NSX250NMA	LC1F225	LTMR08●●	LT6CT2001
110	195	70	NSX250HMA	LC1F225	LTMR08●●	LT6CT2001
132	230	70	NSX400HMA	LC1F265	LTMR08●●	LT6CT4001
132	230	130	NSX400LMA	LC1F265	LTMR08●●	LT6CT4001
160	280	70	NSX400HMA	LC1F330	LTMR08●●	LT6CT4001
160	280	130	NSX400LMA	LC1F330	LTMR08●●	LT6CT4001
200	350	70	NSX630HMA	LC1F400	LTMR08●●	LT6CT4001
200	350	130	NSX630LMA	LC1F400	LTMR08●●	LT6CT4001
220	388	70	NSX630HMA	LC1F500	LTMR08●●	LT6CT4001
220	388	130	NSX630LMA	LC1F500	LTMR08●●	LT6CT4001
250	430	70	NSX630HMA	LC1F500	LTMR08●●	LT6CT8001
250	430	130	NSX630LMA	LC1F500	LTMR08●●	LT6CT8001

Substitution table						
Motor current	Old range LT6P multifunction protection relay			New range TeSys T controllers		
	Reference	Reference	External current transformer Reference	Reference	Reference	External current transformer Reference
	~ 100...240 V	≡ 24 V		~ 100...240 V	≡ 24 V	
I < 5 A	LT6POM005FM	LT6POM005S144	-	LTMR08●FM	LTMR08●BD	-
5 A < I < 25 A	LT6POM025FM	LT6POM025S144	-	LTMR27●FM	LTMR27●BD	-
25 A < I < 100 A	LT6POM005FM	LT6POM005S144	LT6CT1001	LTMR100●FM	LTMR100●BD	-
100 A < I < 200 A	LT6POM005FM	LT6POM005S144	LT6CT2001	LTMR08●FM	LTMR08●BD	LT6CT2001
200 A < I < 400 A	LT6POM005FM	LT6POM005S144	LT6CT4001	LTMR08●FM	LTMR08●BD	LT6CT4001
400 A < I < 800 A	LT6POM005FM	LT6POM005S144	LT6CT8001	LTMR08●FM	LTMR08●BD	LT6CT8001

TeSys

TeSys T Motor management system

Product references

0.37 to 400 kW at 690 V: type 2 coordination

With switch-disconnector, contactor and class 10 controller

Standard power ratings of 3-phase motors 50/60 Hz in category AC-3		Switch-disconnector (1)	aM fuses		Contactor	TeSys T controller	External current transformer
P	I _e	Reference	Size	Rating	Reference	Reference	Reference
kW	A			A			
0.37	0.64	GS●F	14 x 51	1	LC1D09	LTMR08●●	–
0.55	0.87	GS●F	14 x 51	2	LC1D09	LTMR08●●	–
0.75	1.1	GS●F	14 x 51	2	LC1D09	LTMR08●●	–
1.1	1.6	GS●F	14 x 51	2	LC1D09	LTMR08●●	–
1.5	2.1	GS●F	14 x 51	4	LC1D09	LTMR08●●	–
2.2	2.8	GS●F	14 x 51	4	LC1D09	LTMR08●●	–
3	3.8	GS●F	14 x 51	6	LC1D09	LTMR08●●	–
4	4.9	GS●F	14 x 51	6	LC1D09	LTMR08●●	–
5.5	6.7	GS●F	14 x 51	8	LC1D25	LTMR08●●	–
7.5	8.9	GS●F	14 x 51	10	LC1D25	LTMR27●●	–
11	12.8	GS●F	14 x 51	16	LC1D25	LTMR27●●	–
15	17	GS●G	T000	20	LC1D32	LTMR27●●	–
18.5	21	GS●G	T000	25	LC1D32	LTMR27●●	–
22	24	GS●G	T000	32	LC1D40A	LTMR27●●	–
30	32	GS●G	T000	40	LC1D50A	LTMR100●●	–
37	39	GS●J	22 x 58	50	LC1D65A	LTMR100●●	–
45	47	GS●J	22 x 58	63	LC1D80	LTMR100●●	–
55	57	GS●J	22 x 58	80	LC1D115	LTMR100●●	–
75	77	GS●KK	T00	100	LC1D115	LTMR100●●	–
90	93	GS●KK	T00	125	LC1F150	LTMR08●●	LT6CT2001
110	113	GS●KK	T00	125	LC1F185	LTMR08●●	LT6CT2001
132	134	GS●L	T0	160	LC1F265	LTMR08●●	LT6CT2001
160	162	GS●N	T1	200	LC1F265	LTMR08●●	LT6CT2001
200	203	GS●N	T1	250	LC1F330	LTMR08●●	LT6CT4001
220	224	GS●QQ	T2	250	LC1F400	LTMR08●●	LT6CT4001
250	250	GS●QQ	T2	315	LC1F400	LTMR08●●	LT6CT4001
290	292	GS●QQ	T2	355	LC1F500	LTMR08●●	LT6CT4001
315	313	GS●QQ	T2	355	LC1F500	LTMR08●●	LT6CT4001
355	354	GS2S	T3	400	LC1F630	LTMR08●●	LT6CT4001
400	400	GS2S	T3	500	LC1F630	LTMR08●●	LT6CT8001

(1) GS●: GS1 for direct operator, GS2 for external operator.

Characteristics:
pages C1/20 to C1/34

Curves:
page C1/35

Dimensions, mounting:
pages C1/36 to C1/37

Schemes:
pages C1/38 to C1/41



TeSys U, T

Technical Data for Designers

Motor
management
devices

Contents

TeSys U:

- > characteristics..... C1/14 to C1/17
- > dimensions..... C1/18
- > schemes..... C1/19

TeSys T:

- > characteristics..... C1/20 to C1/34
- > curves C1/35
- > dimensions..... C1/36 to C1/37
- > schemes..... C1/38 to C1/41

TeSys

TeSys U Motor management controller

Characteristics

Motor management devices



PB121446 eps

Introduction

Above 32 A, the TeSys U controller provides a motor starter management solution identical to that provided by TeSys U starter-controllers.

Used in conjunction with a short-circuit protection device and a contactor, it provides a motor starter whose functions are the same as those of a TeSys U starter-controller and, in particular, provides the following functions: overload protection, motor starter control and application monitoring.

It consists of a control unit whose adjustment range is compatible with the secondary of current transformers, plus a control base which also allows fitment of a function module or a communication module.

It requires a \sim 24 V external power supply.

The secondaries of current transformers, the \sim 24 V power supply, the 10 inputs and the 5 outputs are connected by screw terminal block.

Application example

Detecting blockage of a rock crusher by monitoring the motor current.

Operating conditions

- Power: 90 kW at 400 V.
- In: 185 A.
- Duty class S1.
- Control circuit voltage: \sim 230 V
- Control-command by PLC and serial link using the Modbus protocol.

Products used

Description	Item	Quantity	Reference	Page
Controller	1	1	LUTM20BL	C1/2
				C1/3
Multifunction control unit	2	1	LUCMT1BL	A4/12
Modbus communication module	3	1	LULC033	A4/27 to A4/31
Current transformer	4	3	LUTC4001	C1/2
				C1/3
Contactor	5	1	LC1F185P7	–
Circuit breaker	6	1	GV5P150F	–

Functions performed

- Short-circuit protection with level of protection of 70 kA at 400V.
- Electronic protection against thermal overloads with an adjustment range of 4.
- Detection of crusher blockage by monitoring the induced overcurrent. To use the "over torque or jam" function, the following parameters must be entered:
 - trip: the answer yes/no enables or disables the function,
 - time before tripping: the time period during which the value of the current must be above the tripping threshold in order to cause tripping (adjustable from 1 to 30 s).
 - tripping threshold: value as a % of the load current ratio in relation to the setting current. If the ratio remains above this threshold for the time specified in the previous parameter, the product trips (adjustable from 100 to 800 %).

It is possible to set the parameter for an alarm at a preset threshold under the same conditions as above.

Ref.



PB121450 eps

PB121437 eps

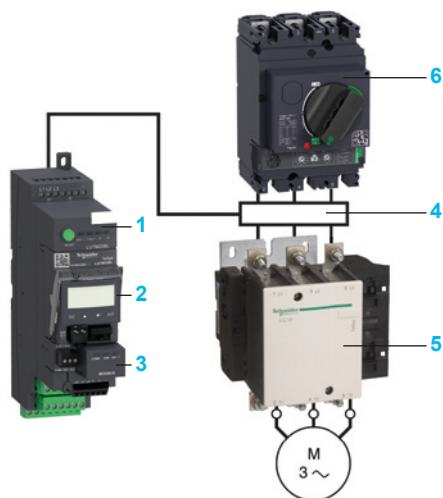

TeSys

TeSys U Motor management controller

Characteristics

Motor management devices

 Ref.

Environment			
Control base and control unit type		LUTM + LUCBT1BL or LUCDT1BL without LULC	LUTM + LUCMT1BL or LULC
Product certifications		UL, CSA, ASEFA	
Conforming to standards		IEC/EN 60947-4-1, UL 508, CSA C22-2 N°14	
Rated insulation voltage of the outputs (Ui)	Conforming to IEC/EN 60947-1, overvoltage category III, degree of pollution: 3	V	250
	Conforming to UL508, CSA C22-2 n°14	V	250
Rated impulse withstand voltage of the outputs (Uimp)	Conforming to IEC/EN 60947-4-1	kV	4
Degree of protection Conforming to IEC/EN 60947-1 (protection against direct finger contact)	Front panel (outside connection zone)		IP 40
	Front panel and wired terminals		IP 20
	Other faces		IP 20
Protective treatment	Conforming to IEC/EN 60068-2-30	Cycles	12
	Conforming to IEC/EN 60068-2-11	h	48
Ambient air temperature around the device	Storage	°C	- 40...+ 85
	Operation	°C	- 25...+ 70 - 25...+ 60
Maximum operating altitude		m	2000
Operating positions Without derating	In relation to normal vertical mounting plane		
Flame resistance	Conforming to UL 94		V2
	Conforming to IEC/EN 60695-2-12	°C	960 (parts supporting live components)
		°C	650
Shock resistance 1/2 sine wave = 11 ms	Conforming to IEC/EN60068-2-27 ⁽¹⁾		15 gn
Vibration resistance 5...300 Hz	Conforming to IEC/EN 60068-2-6 ⁽¹⁾		4 gn
Resistance to electrostatic discharge	Conforming to IEC/EN 61000-4-2	kV	In open air: 8 - Level 3
		kV	On contact: 6 - Level 3
Resistance to radiated fields	Conforming to IEC/EN 61000-4-3	V/m	10 - Level 3
Immunity to fast transient currents	Conforming to IEC/EN 61000-4-4	kV	CT outputs and inputs: 4 - Level 4
		kV	Inputs and supply: 2 - Level 3
Immunity to radioelectric fields	Conforming to IEC/EN 61000-4-6	V	10
Control base and control unit relays			
Immunity to dissipated shock waves	Conforming to IEC/EN 60947-4-1		Common mode Serial mode
	Output relays / power line	kV	4 2
	Inputs	kV	2 1
	Serial communication	kV	2 -

⁽¹⁾ Without modifying the contact states, in the most unfavourable direction.

TeSys

TeSys U Motor management controller

Characteristics

Control circuit supply characteristics			
Operational voltage		V	≈ 20.4...28.8
Power consumption		W	2 max
Associated protection		A	gG fuse, 0.5
Cabling			
Connectors	Pitch	mm	5
Flexible cable without cable end	1 conductor	mm²	0.2...2.5
	2 identical conductors	mm²	0.2...1.5
Flexible cable with cable end			
Without insulated ferrule	1 conductor	mm²	0.25...2.5
	2 identical conductors	mm²	0.25...1
With insulated ferrule	1 conductor	mm²	0.25...2.5
	2 identical conductors ⁽¹⁾	mm²	0.5...1.5
Solid cable without cable end	1 conductor	mm²	0.2...2.5
	2 identical conductors	mm²	0.2...1
Conductor size	1 conductor		AWG24 to AWG12
Tightening torque		N.m	0.5...0.6
Flat screwdriver		mm	3

Input characteristics			
Operational voltage		V	≈ 24
Logic inputs			Logic state 1: $I \geq 6 \text{ mA} - 16 \text{ V}$ Logic state 0: $I \leq 1.5 \text{ mA} - 5 \text{ V}$

Discrete output characteristics			
Base controller type		LUTM10BL	LUTM20BL
Type		Single break volt-free contacts	
Load	a.c. supply	C 300	B 300
	d.c. supply	24 V/5 A	24 V/5 A
Permissible power in cat. AC-15	For 500 000 operating cycles	VA 180	500
Permissible power in cat. DC-13	For 500 000 operating cycles	W 30	30
Associated protection		A gG fuse, 4	gG fuse, 4
Used with contactor type ⁽²⁾		Control voltage ≈ 24 V: LP1K, LC1D09...D95. Control voltage ≈ 24...240 V: LC1K, LC1D.	Control voltage ≈ 100...240 V: LC1K, LC1D, LC1F185...F500

Characteristics of external current transformers LUTC●●●1							
Precision		Class 5P					
Precision limit factor		10					
Maximum operating temperature		°C	70				
Transformer ratio		30/1	50/1	100/1	200/1	400/1	800/1
Diameter of conductor passage hole		mm 28	22	35	32	–	–
Maximum wire c.s.a.		mm² 30 x 10	30 x 10	40 x 10	65 x 32	38 x 127	53 x 127

⁽¹⁾ Use a double cable end.

⁽²⁾ For other combinations, use an intermediate relay between the output of controller LUTM and the contactor coil.

TeSys

TeSys U Motor management controller

Dimensions, mounting

Motor management devices

Dimensions, mounting

Controllers

LUTM●0BL

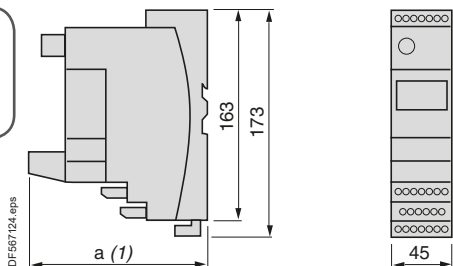

Rail mounting

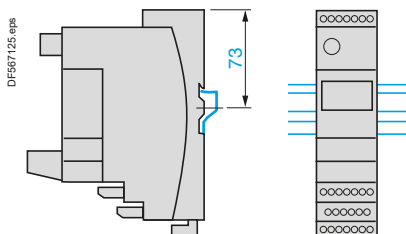

Rail mounting

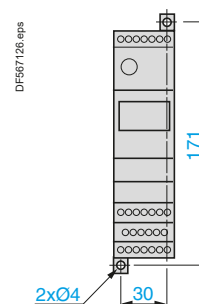

a

With Modbus module	135
With Advantys STB, CANopen or DeviceNet modules	147

(1) Depth with communication module.

Current transformers

LUTC0301...1001

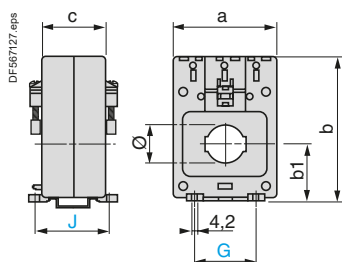

LUTC2001...8001

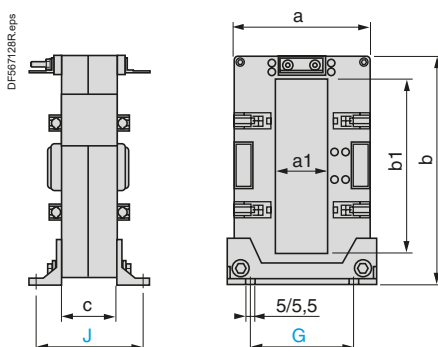

LUTC	a	b	b1	c	Ø	G	J
0301	77	107	42.5	46	28	45	54
0501	56	84	31	42	23	45	50
1001	77	107	42.5	46	35	45	54

LUTC	a	a1	b	b1	c	G	J
2001	90	32	94	55	40	62	62
4001	99	38	160	127	40	75	65
8001	125	54	160	127	40	100	65

TeSys

TeSys U Motor management controller

Schemes

Schemes

Reversing controller LUTM

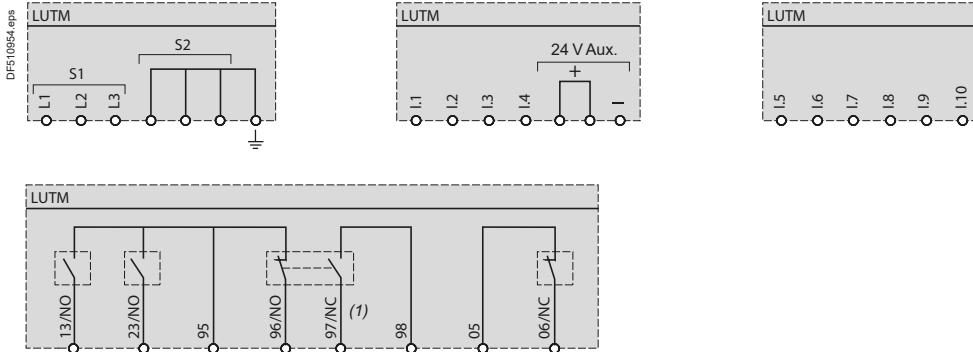

3-wire control, pulsed start with maintaining contact

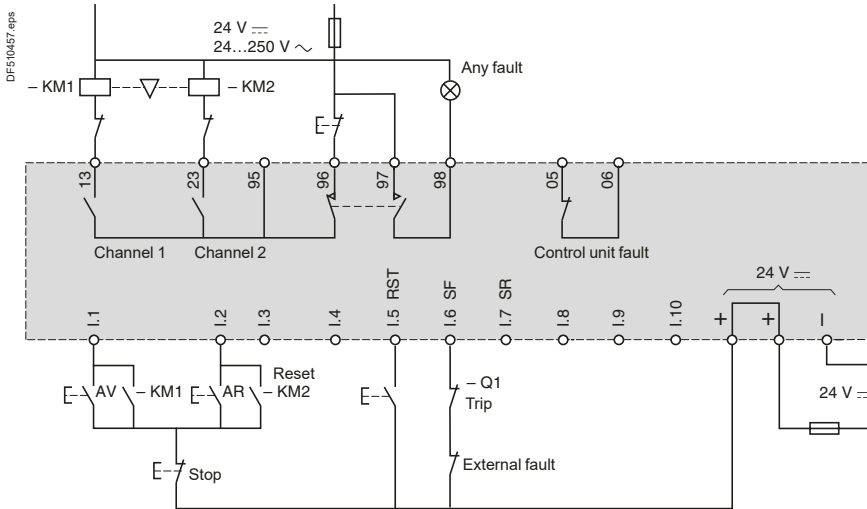

Control for Modbus communication module LULC033

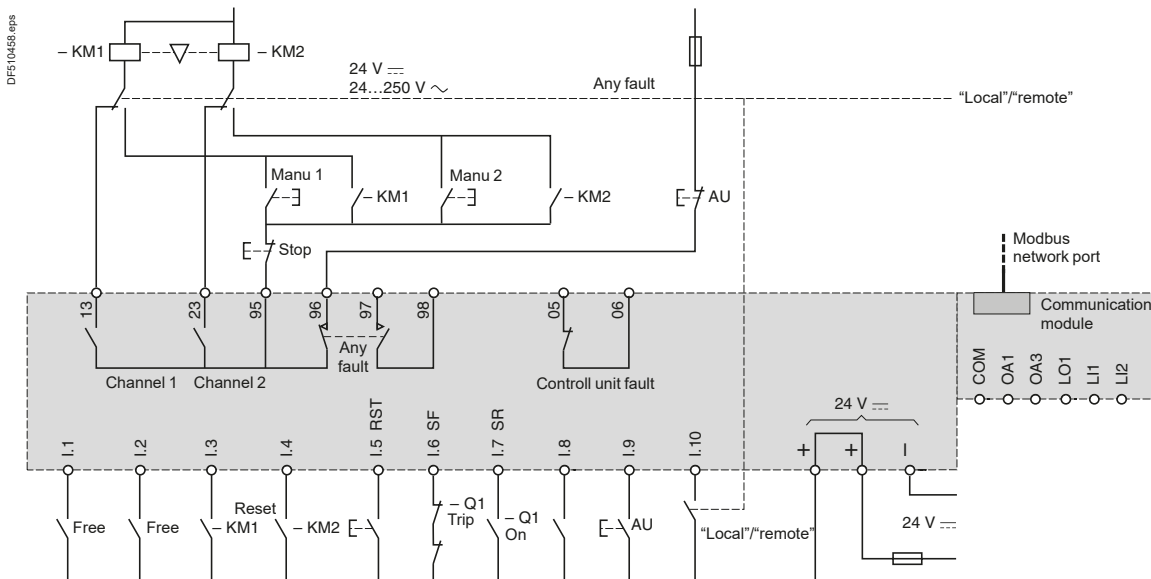

(1) The contacts are represented with controller powered up and not in a fault condition.

Characteristics:
pages C1/14 to C1/17

References:
pages C1/2 and C1/3

Dimensions, mounting:
page C1/18

Motor management devices

Ref.

TeSys

TeSys T Motor management system

Characteristics

Motor management devices

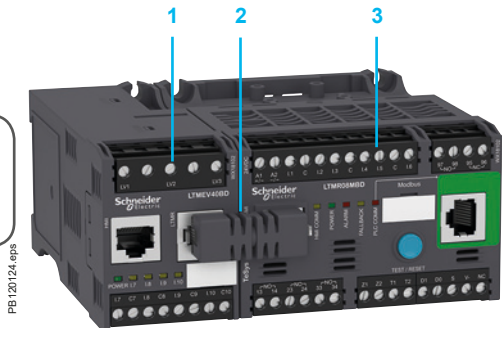

- 1 LTMEV40BD extension module
- 2 LTMCC004 2 x RJ45 jumper
- 3 LTMR08MBD controller

Introduction

TeSys T is a motor management system that provides protection, metering and monitoring functions for single-phase and 3-phase, constant speed, a.c. motors up to 810 A.

Suitable for the harshest applications, this product range offers:

- high-performance multifunction protection, independent of the automation system
- a local HMI control unit for reading, displaying and modifying the parameters monitored, diagnostics, etc.
- configuration using SoMove software
- connection to the automation system via a communication network (selection according to various protocols).

Application

The TeSys T motor management system is used for motor control and protection in harsh industrial applications, in which downtime must be avoided because it is very costly: Oil & Gas, chemical industry, water treatment, metal, minerals and mining, pharmaceutical industry, microelectronics, tunnels, airports etc.

With TeSys T, unexpected stops of a process or manufacturing, associated with a motor, are anticipated via predictive analysis of fault situations. Fault tripping is therefore reduced to a minimum.

Its use in motor control panels makes it possible to:

- increase the operational availability of installations
- improve flexibility from project design through to implementation
- increase productivity by making available all information needed to run the system.

The TeSys motor management system integrates perfectly with Schneider Electric low voltage equipment, such as Okken, Blokset and Prisma.

- Ref.
-
-
-

PB121449.eps



- 1 Magnetic Circuit breaker
- 2 Contactor
- 3 Controller with extension module
- 4 Operator control unit

TeSys

TeSys T Motor management system

Characteristics



PB121434.eps

LTMRO8MBD



PB121436.eps

LTMEV40BD



PB112374.eps

LTMCUF

Introduction

Composition of the motor management system

The system comprises:

- an LTMR motor management controller
 - with internal current transformer up to 100 A
 - above 100 A, by external current transformer up to 810 A
- an LTME extension module
- an LTMCU operator control unit
- configuration software incorporated in the SoMove software application
- accessories for system set-up.

Communication

The LTMR controller is equipped with a communication interface to allow remote monitoring and control of the motor. All motor information is then available at automation system level.

The following networks are available:

- Modbus, CANopen, DeviceNet, Profibus DP and Ethernet TCP/IP (with two communication protocols, Modbus/TCP and EtherNet/IP).

TeSys T system functions

Protection functions

- against thermal overload
- against phase imbalance and phase failure
- thermal motor protection via PTC probes
- against phase reversal
- against earth faults
- against long starting times and motor stalling
- against automatic load shedding and restarting
- against load fluctuations (I, U, P)
- against variations of Cos φ (power factor).

Metering functions

- Measurements (rms values):
 - current on the 3 phases
 - voltage on the 3 phases (shedding)
 - motor temperature
 - earth fault.
- Values calculated:
 - average current
 - frequency
 - Cos φ (power factor), power, power consumption...

Motor control functions

A motor managed by TeSys T can be controlled:

- locally, using the logic inputs present on the product, or via the HMI terminal
- remotely, via the network (connection by terminal block or connector except for DeviceNet: terminal block only).

Motor control modes

5 predefined motor control modes are incorporated in the controller:

- overload mode: monitoring of motors whose control is not managed by the controller,
- independent mode: starting of non-reversing motors,
- reverser mode: starting of reversing motors,
- 2-step mode: 2-step starting of motors (star-delta, by autotransformer and by resistor),
- 2-speed mode: 2-speed starting of motors (Dahlander, pole changer).

A 6th "Custom" mode is available to allow the user to create a specific motor control mode that is not predefined in the controller.

Statistical and diagnostic functions

- Fault statistics: counters per type of protection and history of the last 5 faults.
- Motor statistics: saving of motor statistics values.
- Diagnosis of faults affecting correct operation of the product.

Motor management devices

Ref.



TeSys

TeSys T Motor management system

Characteristics

Motor management devices



PE121447.eps

LTMR●●

Ref.



The LTMR controller

The controller is the central component in the motor management system. It manages the basic functions such as:

- measurement of 3-phase current via integral current transformers from 0.4 to 100 A (up to 810 A by external current transformers)
- measurement of earth current by external earth fault toroid
- measurement of motor temperature by PTC probe
- inputs and outputs for the various motor control modes, fault management and associated functions.

Characteristics

Supply

2 types of controller power supply are available:

- 24 V $\overline{\text{DC}}$
- 100...240 V \sim .

Current ranges

3 current ranges allow measurement of motor current from 0.4 to 100 A:

- 0.4...8 A
- 1.35...27 A
- 5...100 A.

For use with external current transformers, choose the 0.4...8 A range (1 or 5 A current transformer secondary).

Inputs

- 6 discrete logic inputs.

Outputs

- 3 relay logic outputs (1N/O).
- 1 relay output for fault signalling (1N/O + 1N/C).

Measurements

- Connections for a temperature probe.
- Connections for an earth fault toroid.

LTME extension module

The extension module adds the following functionalities to the TeSys T controller:

- voltage measurement on the 3 phases. This enables it to calculate numerous engine monitoring parameters (power, frequency, Cos ϕ ...)
- 4 additional inputs.

Characteristics

Inputs

- 4 discrete logic inputs (independent).

Power supplies

- 2 types of power supply for the inputs: 24 V $\overline{\text{DC}}$ and 100...240 V \sim .
- A 24 V $\overline{\text{DC}}$ expansion module can be assembled with a 24 V $\overline{\text{DC}}$ controller or with a 100...240 V \sim controller.
- A 100...240 V \sim expansion module can be assembled with a 100...240 V \sim controller.

Voltage measurement between phases up to 690 V nominal.

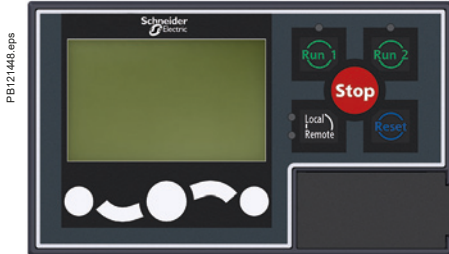

LTMCU

Human/Machine Interfaces (HMI)

Depending on the application, 2 types of HMI can be used with the LTMCR controller.

- The LTMCU operator control unit:
 - entirely dedicated to the TeSys T range
 - only for control/monitoring of an LTMCR controller.
- A Magelis XBTN410 terminal for control/monitoring of 1 to 8 LTMCR controllers.

LTMCU operator control unit

Dedicated exclusively to TeSys T controllers, control unit LTMCU makes it possible to:

- configure the parameters of the LTMCR controller
- display information on controller configuration and operation
- monitor the alarms and faults generated by the controller
- local control of the motor via the local control interface (keys can be customised). Three different languages can be loaded into the LTMCU controller at the same time.

By default, these 3 languages are:

- LTMCU: English, French and Spanish

Note: English is the only compulsory language.

A language download utility (LangTool), together with all the other languages, are available on the website "www.se.com".

This tool allows the languages present in the LTMCU control unit to be adapted.

The LTMCU HMI control unit has an RJ45 port, protected by a flexible cover to provide a good level of protection (IP54).

This port on the front panel allows connection to a PC, via a connecting cable, in order to use SoMove software.

In this case, the control unit acts as a transmitter and all information can then be viewed in SoMove.

The LTMCU HMI can be used as a portable version by using the separate kit LTM9KCU. This kit consists of two snap-on plastic shells (tool-free mounting) fitted with a simple fixing system that uses magnets for mounting on all types of metal surfaces.

The Magelis XBT N410 HMI terminal

Two applications have been predefined for TeSys T. Depending on the application loaded, the HMI terminal makes it possible to:

- configure and monitor a motor starter (LTM_1T1_V1.dop)
- monitor and modify certain parameters on up to 8 motor starters (LTM_1T8_X_V1.dop)⁽¹⁾.

XBTL1000 programming software is needed for loading applications into the HMI terminal.

These applications are available on the website "www.se.com".

⁽¹⁾ Replace the X with an E for the English version, or an F for the French version.

TeSys

TeSys T Motor management system

Characteristics

Motor management devices

LTMR controllers

Modbus

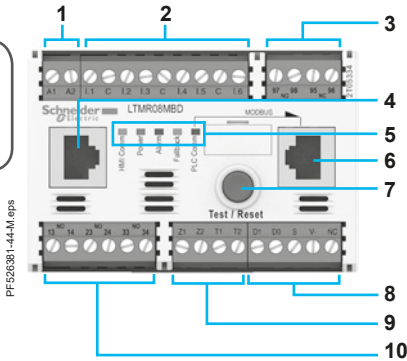

DeviceNet

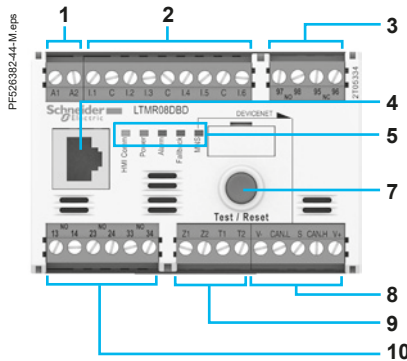

Profibus DP

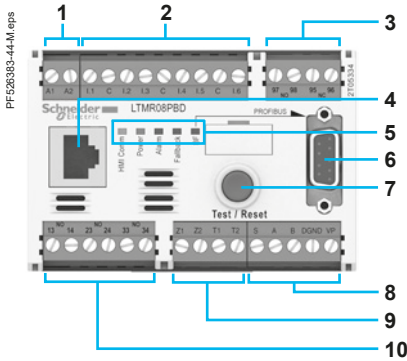

CANopen

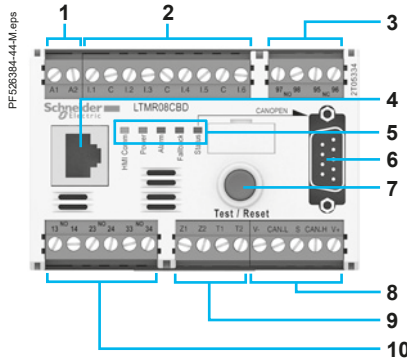

Ethernet TCP/IP (communication protocols: Modbus/TCP and EtherNet/IP)

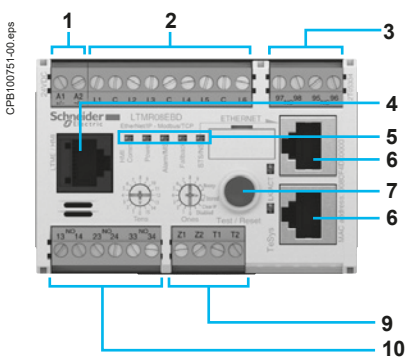

Controllers feature the following on their front panel:

- 1 Controller power supply.
- 2 Input connections.
- 3 Fault outputs (N/O+N/C).
- 4 Port for connection to the HMI terminal, a PC or an extension module (RJ45).
- 5 Controller status LEDs.
- 6 Network port for connection to the network by connector (except DeviceNet) ⁽¹⁾.
- 7 Test/Reset button.
- 8 Connection to the network by terminal block (except Ethernet TCP/IP).
- 9 Connection for an earth fault toroid and temperature probes.
- 10 Outputs for motor control mode function.

- Ref.
-
-
-

⁽¹⁾ Connection using power extension (daisy-chaining) is possible for Ethernet TCP/IP.

LTMEV40 extension modules

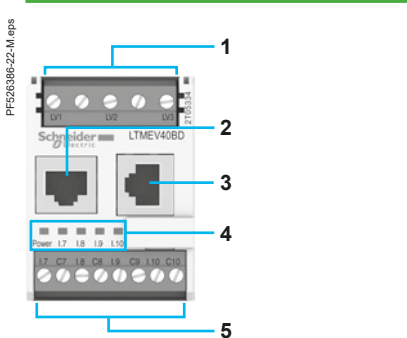

LTMCU operator control unit

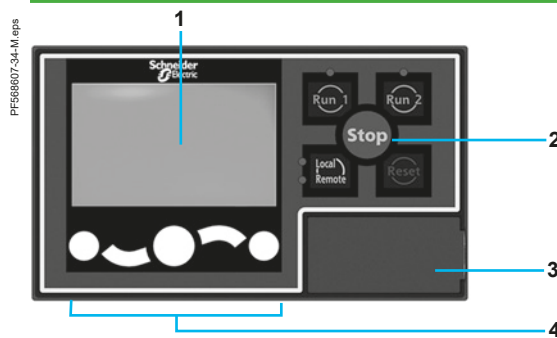

Extension modules have the following on their front face:

- 1 Inputs for voltage measurement.
- 2 Port for connection to the HMI terminal or to the PC.
- 3 Port for connection to the controller.
- 4 Extension module status LEDs.
- 5 Connection of additional inputs.

The control unit has the following on its front face:

- 1 Screen LCD display.
- 2 Local control interface including control keys and LEDs.
- 3 RJ45 port on front panel for connection to a PC (protected by a cover).
- 4 Contextual navigation keys.

Thermal and current protection functions					
Functions	Setting range	Controller LTMR	Controller and extension module (LTMR + LTME)	Alarm threshold	Fault threshold
Description					
Thermal overload: thermal protection of motor by monitoring current consumption	Class: 5, 10, 15, 20, 25, 30. Inverse ther/definite time				
Motor temperature: thermal monitoring of the motor using temperature probes (winding, paper...). Up to 3 sensors in series.	PTC binary PTC/NTC analogue: 20 ...6500 Ohm				
Phase imbalance: monitors the symmetry of currents. To be used for imbalance < 80 % of the average current ⁽¹⁾ .	10...70% I average 0.2...20 s				
Phase failure: monitors the symmetry of currents. To be used for imbalance < 80 % of the average current ⁽¹⁾ .	0.1...30 s				
Phase reversal: signals when the phase sequence is different from the defined sequence (motor running).	A-B-C A-C-B				
Long starting time: monitors the motor starting time	100...800 % of FLC ⁽²⁾ 1...200 s				
Locked rotor: locking detected by a sudden increase in current after the start phase	100...800 % of FLC ⁽²⁾ 1...30 s				
Min/max current load limit variations: monitors motor load through variations of current around preset thresholds.	min.: 30...100 % of FLC ⁽²⁾ 1...200 s max.: 20...800 % of FLC ⁽²⁾ 1...250 s				
Earth fault: signals internal insulation faults, by vectorial summing of external currents, via earth fault toroid.	internal: 50...500 % min FLC ⁽²⁾ 0.5...25 s external: 0.02...21 A 0.1...25 s				
Frequent starting: Protects the motor against overheating due to frequent starting.	0...999.9 s				

Voltage and power protection functions					
Functions	Setting range	Controller LTMR	Controller and extension module (LTMR + LTME)	Alarm threshold	Fault threshold
Description					
Phase imbalance: monitors the symmetry of voltage between phases. To be used for imbalance < 40 % of the average voltage ⁽³⁾ .	3...15 % 0.2...20 s				
Phase failure: monitors the symmetry of voltage between phases. To be used for imbalance > 40 % of the average voltage ⁽³⁾ .	0.1...30 s				
Phase reversal: signals when the phase sequence is different from the defined sequence (motor stopped).	A-B-C A-C-B				
Voltage variations. Min/max voltage limits: monitors voltage variations around preset thresholds.	min.: 70...99 % 0.2...25 s max.: 101...115 % 0.2...25 s				
Load shedding: opens outputs O.1 and O.2 if voltage drops below a preset threshold.	68...115 % 1...9999 s				
Power variations. Min/max power limits: monitors power variations around preset thresholds.	20...800 % 1...100 s				
Variations of Cos φ. Min/max limits of Cos φ: monitors variations of Cos φ around preset thresholds.	0...1 s 1...25 s				

Function performed.

⁽¹⁾ Average current value measured on the 3 phases.

⁽²⁾ FLC: Full Load Current (setting current).

⁽³⁾ Average voltage value measured on the 3 phases.

TeSys

TeSys T Motor management system

Characteristics

Motor management devices

Motor control functions

Functions	Description	With controller LTMR	With controller LTMR and extension module LTME
Control modes	Local, via terminal block	■	■
	Local, via HMI terminal ⁽¹⁾	■	■
	Remote, via network	■	■
Operating modes	Overload	■	■
	Independent	■	■
	Reverser	■	■
	2-step	■	■
	2-speed	■	■
	"Custom" mode	■	■
Fault management	Manual reset	■	■
	Automatic reset	■	■
	Remote reset	■	■

Metering functions and statistics

Functions	Description	Measurement range	With controller LTMR	With controller LTMR and extension module LTME
Measurements ⁽²⁾	Current/Phase	0.08...1000 A	■	■
	Earth current	0.1633 x CT ratio	■	■
	Average current	0.08...1000 A	■	■
	Current imbalance between phases	0...200 %	■	■
	Thermal capacity level	0...200 %	■	■
	Motor temperature rise	0...6500 Ohm	■	■
	Frequency	0... 100 Hz	■	■
	Voltage between phases	~ 0...830 V	■	■
	Voltage imbalance between phases	0...200 %	■	■
	Active power	0...6553.5 kW	■	■
	Reactive power	0...6553.5 kWr	■	■
	Cos φ (power factor)	0...100	■	■
	Active power consumption	0...400 kWh	■	■
	Reactive power consumption	0...400 kWrh	■	■
Fault statistics	Protection fault counters		■	■
	Protection alarm counters		■	■
	Diagnostic fault counters		■	■
	Motor control function counters		■	■
	Fault history		■	■
Fault diagnostics	Internal watchdog fault		■	■
	Controller internal temperature		■	■
	Temperature sensor connection		■	■
	Current connection		■	■
	Voltage connection		■	■
	Motor control commands (start, stop, run check back and stop check back)		■	■
	Control configuration checksum		■	■
Motor statistics	Loss of communication		■	■
	Number of motor control commands (O.1/O.2 starts)		■	■
	Operating time		■	■
	Number of starts/hour		■	■
	Last start I max.		■	■
Thermal overload statistics	Duration of last start		■	■
	Time to trip		■	■
System operating statistics	Time to restart		■	■
	Run, ON, Start, alarm, fault.		■	■

(1) HMI: Human Machine Interface.

(2) See measurement details page C1/32.



TeSys

TeSys T Motor management system

Characteristics

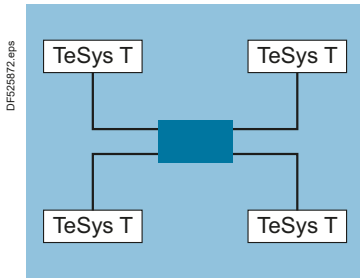

Star topology

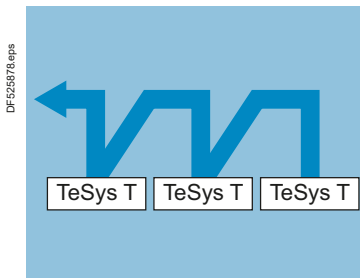

Daisy chain topology

Star topology

In a star topology, all the peripherals are linked via an intermediate peripheral (hub or switch).

In industrial Ethernet applications, the use of full duplex switches (instead of hubs) as central peripherals is strongly recommended.

Daisy chain topology

Daisy chaining, at bus level, is another connection topology commonly used in industrial automation system networks. The cable segments link several peripherals to each other, constituting the peripheral "section" of the network cable.

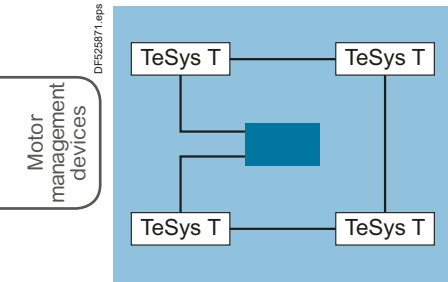

Ring topology

Ethernet: different network topologies

Ring topology

In a ring topology, all the peripherals or components of the network infrastructure are connected within a loop. This type of topology makes it possible to achieve different levels of redundancy of the network.

Ethernet ring

Ethernet rings are generally the main networks in applications where a high level of reliability is required. If a ring topology is required, the switches handling this function must be used.

Redundancy

Redundancy of the network infrastructure is the key to development of applications with high operational reliability. Implementing a single or double ring architecture makes it possible to provide protection against breaks in network segments.

Single ring

The first level of redundancy can be achieved by installing a single ring. ConneXium switches can be used to establish main network ring configurations. The ring is created using RSTP protocol. If a section of the line fails, the ring structure converts into a line type configuration.

Ethernet: different communication protocols

LTMR controllers communicating over an Ethernet network can communicate either using the Modbus/TCP communication protocol or using the EtherNet/IP communication protocol. Both protocols are loaded in the controller. One must be selected for the operation.

Note: EtherNet/IP communication protocol is supported by ODVA, also promoter of DeviceNet communication solution. Note that in EtherNet/IP, IP stands for Industrial Protocol.

- IP address Class for Ethernet TCP/IP version: Class A 20 ETH10/100.

Services available on Ethernet TCP/IP version

	In Modbus/TCP	In Ethernet/IP
Web Server	■	■
Modbus messaging	■	
IO Messaging		■
Explicit Messaging		■
Client FDR	■	■
SNMP network administrator	■	■
RSTP	■	■
Discovery	■	■
Master IP	■	■
Broadcast Storm Protection	■	■

Ref.



TeSys

TeSys T Motor management system

Characteristics

Possible configurations and applications

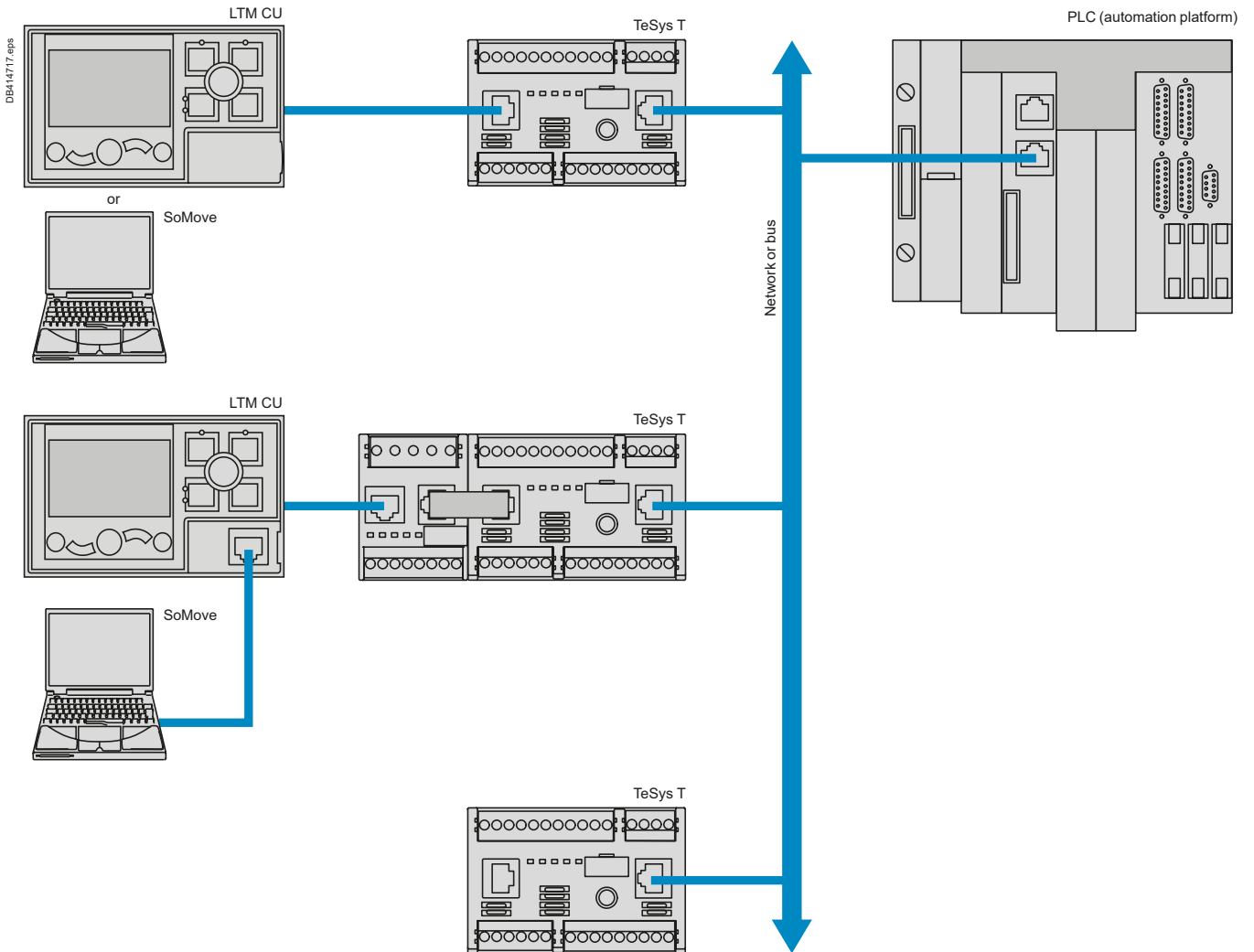

Motor management devices

- Ref.
-
-
-

TeSys

TeSys T Motor management system

Characteristics

Motor
management
devices

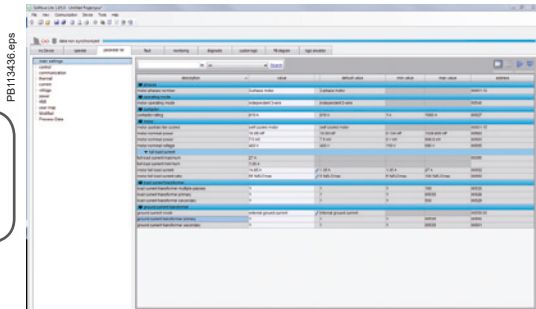

Example of TeSys T configurator setup screen

Configuration with SoMove

The TeSys T configurator is incorporated in the SoMove software application, as from version 2.5. ⁽¹⁾

It allows configuration, commissioning and maintenance of motor starters protected by TeSys T.

A library containing predefined motor control mode functions is available in order to:

- allow standardisation
- avoid errors
- reduce motor starter setup times.

5 predefined motor control modes are incorporated in the controller:

- overload mode: monitoring of motors whose control is not managed by the controller
- independent mode: starting of non-reversing motors
- reverser mode: starting of reversing motors
- 2-step mode: 2-step starting of motors (star-delta, by autotransformer and by resistor)
- 2-speed mode: 2-speed starting of motors (Dahlander, pole changer).

By using logic functions, a "Custom" mode makes it possible to:

- easily adapt these predefined motor control mode functions to the specific needs of your applications
- create a link with the motor starter environment or
- create new functions.

The functions thus defined can be saved and used to build your function library for future applications.

To create special functions, a logic editor is incorporated in the configurator and allows a choice of 2 programming languages:

- function block
- structured text.

⁽¹⁾ An update file is available, free of charge, on the website "www.se.com".

It will enable you to take advantage of the latest functions in the TeSys T motor management system.

Ref.



TeSys

TeSys T Motor management system

Characteristics

Environment				LTMR controllers		LTMEV40 extension modules		
Product type				IEC/EN 60947-4-1, UL60947-4-1A, CSA 22-2 n°60947-4-1, IACS E10				
Conforming to standards				IEC/EN 60947-4-1, UL60947-4-1A, CSA 22-2 n°60947-4-1, IACS E10				
Product certifications				UL, CSA, CE, CCC, EAC/GOST, RCM/CTICK, Atex, Marine (BV, LROS, DNV, RINA, ABS) ⁽¹⁾				
Rated insulation voltage of the outputs (Ui)	Conforming to IEC/EN 60947-1, overvoltage category III, degree of pollution 3	V	690					
	Conforming to UL 508, CSA C222 n° 14	V	690					
Rated impulse withstand voltage (Uimp)	Conforming to IEC/EN 60947-4-1							
	~ 100...240 V supply, inputs and outputs	kV	4		4			
	--- 24 V supply, inputs and outputs	kV	0.8		0.8			
	Communication circuits	kV	0.8		–			
	Current or voltage measurement circuit	kV	6		6			
Short-circuit withstand	Conforming to IEC/EN 60947-4-1	kA	100					
Climatic withstand	Conforming to IEC/EN 60068-2-30			12 x 24 hour cycles				
	Conforming to IEC/EN 60070-2-11	h	48					
Ambient air temperature around the device	Storage	°C	-40...+80					
	Operation	°C	-20...+60					
Operating position without dating	In relation to normal vertical mounting plane			±30° in relation to mounting plate, ±90°				
Flame resistance	Conforming to UL 94	°C	960 (for parts supporting live components)					
	Conforming to IEC/EN 60695-2-12	°C	650 (for other parts)					
Shock resistance (1/2 sine wave, 11 ms)	Conforming to IEC/EN 60068-2-27 ⁽²⁾			15 gn				
Vibration resistance	Conforming to IEC/EN 60068-2-6 ⁽²⁾ 5...300 Hz			4 gn (plate mounted) 1 gn (mounted on rail)				
Resistance to electrostatic discharge	Conforming to IEC/EN 61000-4-2	kV	In open air: 8 - Level 3 On contact: 6 - Level 3					
Immunity to radiated electromagnetic interference	Conforming to IEC 61000-4-3	V/m	10 - Level 3					
Immunity to fast transient bursts	Conforming to IEC 61000-4-4	kV	On supply and relay outputs: 4 - Level 4 Other circuits: 2 - Level 3					
Immunity to radioelectric fields ⁽³⁾	Conforming to IEC/EN 61000-4-6	V	10 - Level 3					
Immunity to dissipated shock waves	Conforming to IEC/EN 61000-4-5			Common mode	Serial mode	Common mode	Serial mode	
	Relay outputs and supply	kV	4	2	–	–		
	--- 24 V inputs	kV	1	1	1	1		
	~ 100...240 V inputs	kV	2	1	2	1		
	Voltage inputs	kV	–	–	4	2		
	Communication	kV	2	–	2	–		
	Temperature sensor (IT1/IT2)	kV	1	0.5	–	–		
Altitude derating			2000 m	3000 m	3500 m	4000 m	4500 m	
	Rated operational voltage (Ui)		1	0.93	0.87	0.8	0.7	
	Max. operating temperature		1	0.93	0.92	0.9	0.88	

(1) Certain certifications are pending; please consult your Customer Care Centre.

(2) Without modifying the contact states, in the most unfavorable direction.

(3) This product has been designed for use in environment A and in B, it may cause unwanted electromagnetic disturbance to other devices, which may require the implementation of adequate mitigation measures.

Motor management devices

Ref.



Controller and extension module characteristics							
Product type			Controllers		Extension modules		
			LTMR●●●BD	LTMR●●●FM	LTMEV40BD	LTMEV40FM	
Control supply							
Operational voltage (U)	Conforming to IEC/EN 60947-1	V	≡ 24	~ 100...240	-		
Resistance to voltage dips	Conforming to IEC/EN 61000-4-11	V	0 for 3 ms 70 % of U for 500 ms		-		
Associated protection		A	gG fuse, 0.5		-		
Operational voltage	Limit values	V	≡ 20.4...26.24	~ 93.5...264	-		
Current consumption	50/60 Hz	mA	≡ 56...127	~ 8...62.8	-		
Connectors	Pitch	mm	5.08		5.08		
Flexible cable without cable end	1 conductor	mm ²	0.2...2.5		0.2...2.5		
	2 identical conductors	mm ²	0.2...1.5		0.2...1.5		
Flexible cable with cable end	Without insulated ferrule	1 conductor	0.25...2.5		0.25...2.5		
		2 identical conductors	0.5...1.5		0.5...1.5		
	With insulated ferrule	1 conductor	0.25...2.5		0.25...2.5		
		2 identical conductors	0.2...1		0.2...1		
Solid cable without cable end	1 conductor	mm ²	0.2...2.5		0.2...2.5		
	2 identical conductors	mm ²	0.2...1		0.2...1		
Conductor size			AWG24 to AWG14		AWG24 to AWG14		
Tightening torque		N.m	0.5...0.6		0.5...0.6		
Flat screwdriver		mm	3		3		
Input characteristics							
Nominal values	Conforming to IEC/EN 61131-1		Type 1 positive logic (≡: resistive, ~: capacitive)				
	Voltage	V	≡ 24	~ 100...240	≡ 24	~ 100...240	
	Current	mA	≡ 7	~ 3.1 for 100 V ~ 7.5 for 240 V	≡ 7	~ 3.1 for 100 V ~ 7.5 for 240 V	
Logic inputs	Logic state 1	Voltage	V	15 min	79 < U < 264	15 min	79 < U < 264
		Current	mA	2 min...15 max	2 min at 110 V... 3 min at 220 V	2 min...15 max	2 min at 110 V... 3 min at 220 V
	Logic state 0	Voltage	V	5 max	0 < U < 40	5 max	0 < U < 40
		Current	mA	15 max	15 max	15 max	15 max
Response time	Change to state 1	ms	15	25	15	25	
	Change to state 0	ms	5	25	5	25	
Output characteristics							
Type			Volt free, single break				
Load	~		250 V / 5 A B300				
	≡		30 V / 5 A				
Permissible power in cat. AC-15	For 500 000 operating cycles	VA	480 / Ie max: 2 A				
Permissible power in cat. DC-13	For 500 000 operating cycles	W	30 / Ie max: 1.25 A				
Associated protection		A	gG fuse, 4				
Max. frequency		Hz	2				
Max. operating level		op. cycles/h	1800				
Response time	Change to state 1	ms	10 max				
	Change to state 0	ms	10 max				
Measurement details							
Current			1 % for the 0.4...8 A and 1.35...27 A ranges 2 % for the 5...100 A range				
Voltage			1 % from 100 to 830 V				
Earth fault current	Internal measurement without earth fault toroid		5...15 % for current > 0.1 A in the 0.4...8 A range current > 0.2 A in the 1.35...27 A range current > 0.3 A in the 5...100 A range				
	External measurement with earth fault toroid		< 5 % or 0.01 A				
Temperature measurement			2 %				
Power factor			10 %				
Active and reactive power			15 %				
Internal clock			±30 min / year				

Bus and network characteristics

Type of bus/network	Modbus	CANopen	DeviceNet	Profibus DP	Ethernet
Physical interface	2-wire RS 485	ISO 11898	ISO 11898	polarised 2-wire RS 485	IEEE 802.3
Addressing	1 to 247	1 to 127	1 to 64	1 to 125	0 to 159 ⁽¹⁾
Transmission speeds	1.2 to 19.2 kb/s	10, 20, 50, 125, 250, 500, 800 and 1000 kb/s + Auto baud	125 to 500 kb/s	9.6 kb to 12 Mb/s	10/100 Mb/s, with automatic recognition
Connections	RJ45/terminal block	9-way SUB-D/terminal block	Terminal block	9-way SUB-D/terminal block	RJ45
Cables	2 shielded twisted pairs	4 twisted, shielded wires	4 twisted, shielded wires	2 shielded twisted pairs, type A	2 shielded twisted pairs

Motor management devices

LTMCU operator control unit

Environment

Conforming to standards		IEC/EN 61131-2, UL60947-4-1A, CSA 22-2 n°60947-4-1
Product certifications		UL, CSA, CE, EAC/GOST, RCM/CTIC'K
Ambient air temperature around the device	Storage Operation	°C °C
		-40...+80 -20...+60
Relative humidity		15...95 % without condensation
Climatic withstand	Conforming to IEC/EN 60068-2-30	12 x 24 hour cycles
Degree of protection	Conforming to IEC 60947-1	IP54
Shock resistance	Conforming to IEC/EN 60068-2-27	15 gn / 11ms
Vibration resistance	Conforming to IEC/EN 60068-2-6 5...300 Hz	4 gn
Flame resistance	Conforming to IEC 60947-1 Conforming to UL 94	°C V2
		650

Electrical characteristics

Supply to the product		Powered via the controller
Maximum current	mA	140
Maximum power dissipated	W	1
Resistance to electromagnetic discharge	Conforming to IEC/EN 61000-4-2	kV
		In open air: 8. Level 3 On contact: 4. Level 3
Immunity to radiated electromagnetic interference	Conforming to IEC/EN 61000-4-3	V/m
		10 - Level 3
Immunity to fast transient bursts	Conforming to IEC/EN 61000-4-4	kV
		2, shielded access. Level 3
Immunity to radioelectric fields	Conforming to IEC/EN 61000-4-6	V
		10. Level 3
Immunity to shock waves	Conforming to IEC/EN 61000-4-5	kV
		2, shielded access. Level 3

Physical characteristics

Mounting		Flush mounted
Display		Backlit LCD
Signalling		By 4 LEDs
Cabling		RJ45

⁽¹⁾ For DHCP, stored IP, addressing limited by subnet mask.

TeSys

TeSys T Motor management system

Characteristics

Motor management devices

LT6CT●●●● external current transformer characteristics

Conforming to standards	IEC 60185, BS 7626				
Precision	Class 5P				
Precision limit factor	15				
Rated insulation voltage (Ui)	690				
Maximum operating temperature	°C	50			
Transformer ratio	A	100/1	200/1	400/1	800/1
Diameter of conductor passage hole	mm	35	35	35	35
Maximum cabling c.s.a.	mm ²	30 x 10	30 x 10	30 x 10	incorporated ⁽¹⁾

Earth fault toroid characteristics

Toroid type		50437	50438	50439	50440	50441	50442	50485	50486
Rated insulation voltage Ui	V	1000							
Operating temperature	°C	- 35... + 70							
Protection index		IP30 (connections IP20)							
Transformer ratio		1/1000							
Rated operational current Ie	A	65	85	160	250	400	630	85	250
Max. conductor c.s.a. per phase	mm ²	25	50	95	240	2 x 185	2 x 240	50	240

DA1TT●● probe characteristics

Conforming to standards		IEC 60034-11 mark A	
Economy resistor	At 25 °C	Ω	3 x 250 in series
Rated operational voltage (Ue)	Per probe	V	~ 2.5 max
Rated insulation voltage (Ui)		kV	2.5
Insulation			Reinforced
Length of connecting cables	Between probes	mm	250
	Between probe and motor terminal plate	m	1

Guaranteed operating zones: example with 3 probes type DA1TT●●● (250 Ω at 25 °C) in series, conforming to standard EC 60034-11, mark A.

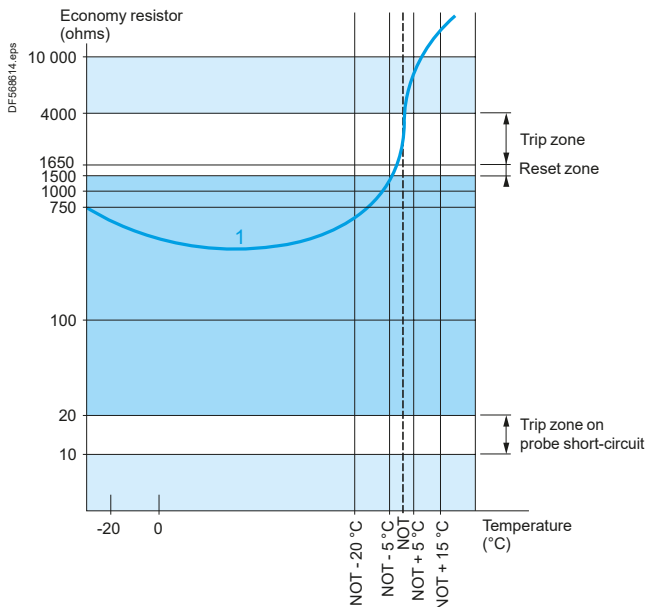

1 3 probes type DA1●●● (250 Ω at 25 °C) in series.

NOT: Nominal Operating Temperature.

Protection unit tripped.

Protection unit reset.

⁽¹⁾ Electrical connection to be made using M10 bolt.

Cold state curves

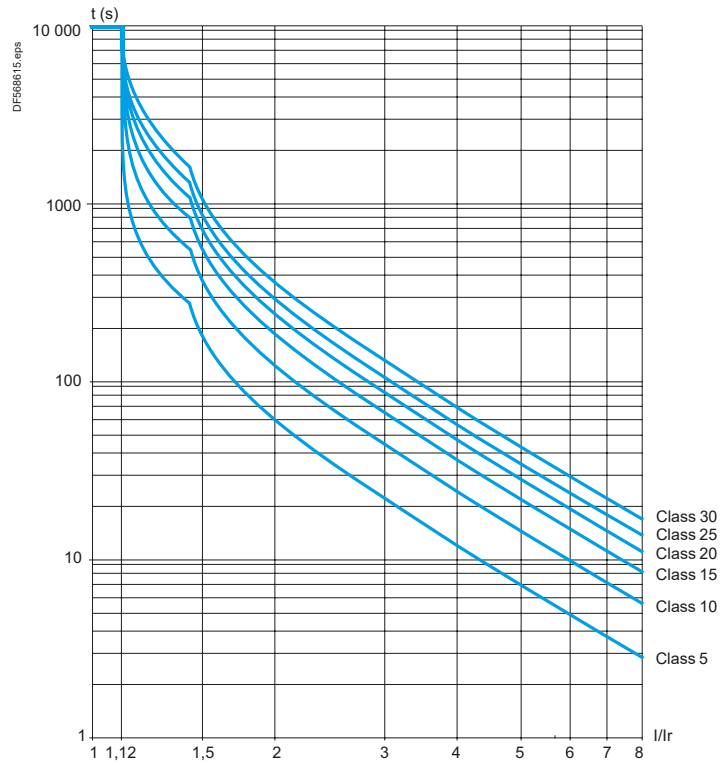

Hot state curves

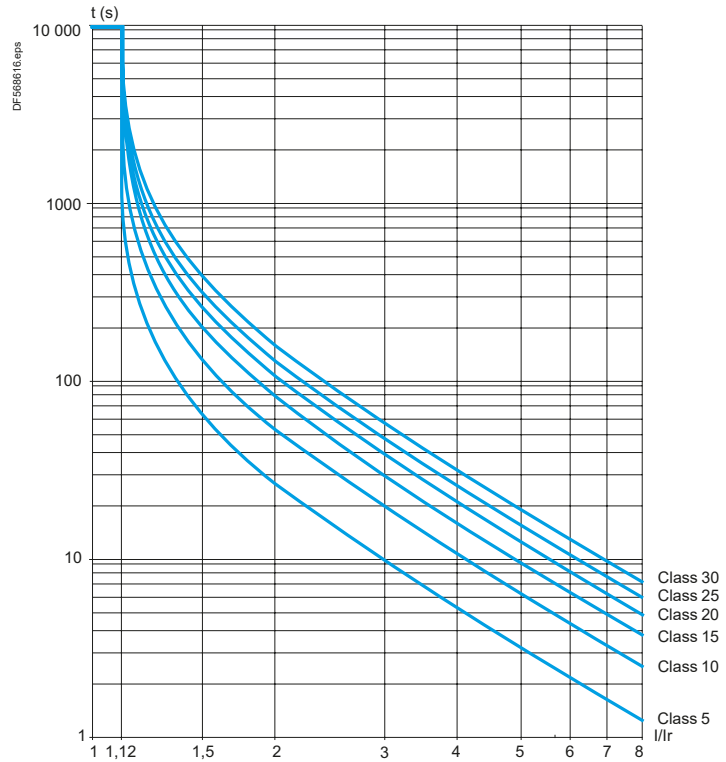

TeSys

TeSys T Motor management system

Dimensions, mounting

LTMR●● controllers

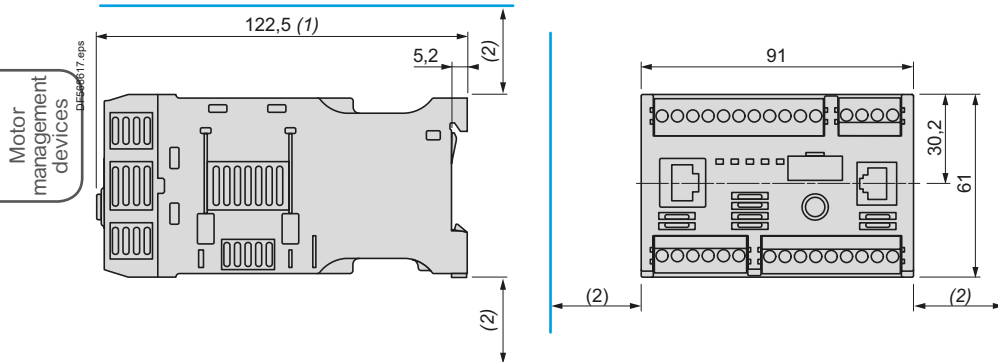

LTMEV40●● extension modules

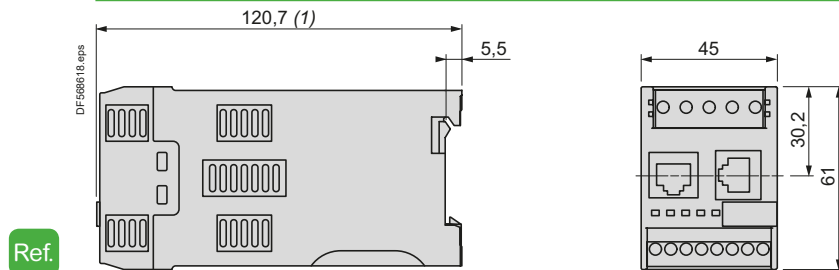

LTMCU operator control unit

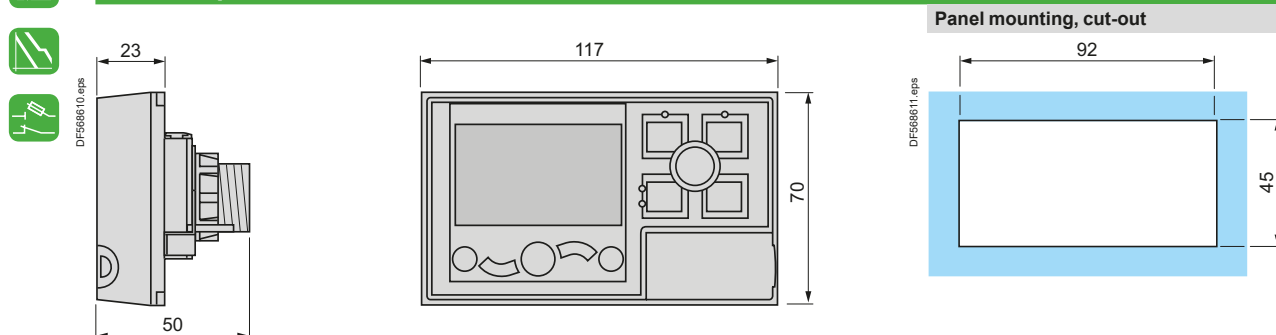

LTM9F

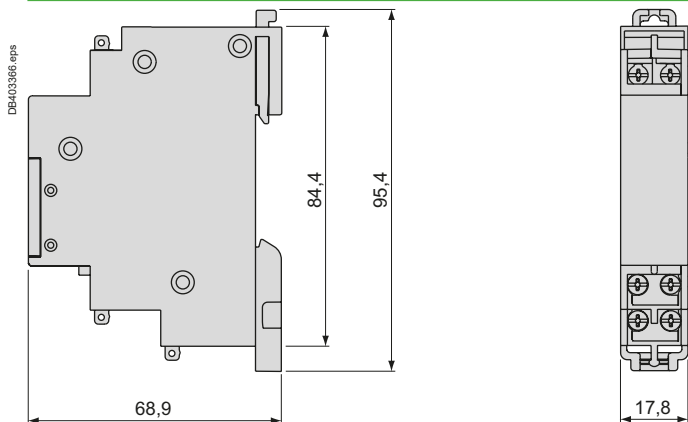

(1) 140 mm with RJ45 connector for connection to extension module and to network, 166 mm with Profibus DP/CANopen connector.

(2) Leave a gap around the device of: 9 mm at 45 °C, 9 to 40 mm from 45 to 50 °C, 40 mm at 60 °C.

TeSys

TeSys T Motor management system

Dimensions

Current transformers

LT6CT

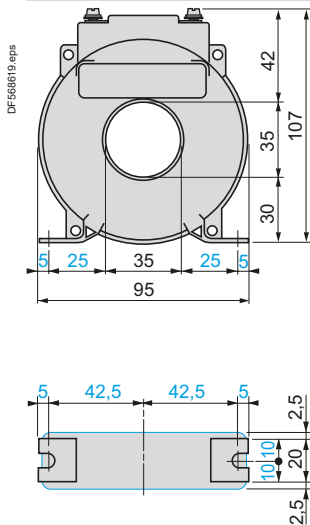

HMI terminal

XBTN410

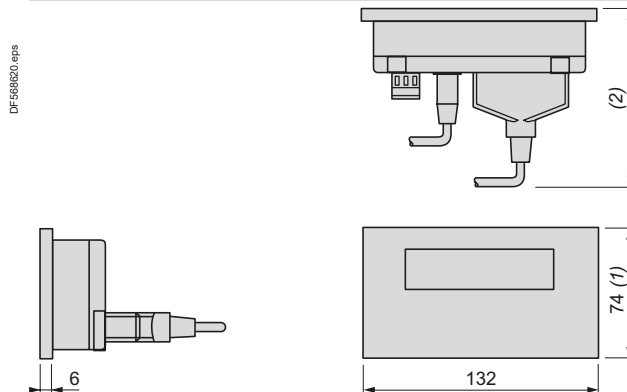

- (1) 104 mm with fixing clips (supplied with the product).
 (2) 58 mm with SUB-D 25-way elbowed cable **XBTZ9680** for Twido, TSX Micro and Premium or **XBTZ998** for Advantys STB.
 104 mm with SUB-D 25-way cable **XBTZ68/Z9681** for Twido, TSX Micro and Premium.

Earth fault toroids

50437 and 50438

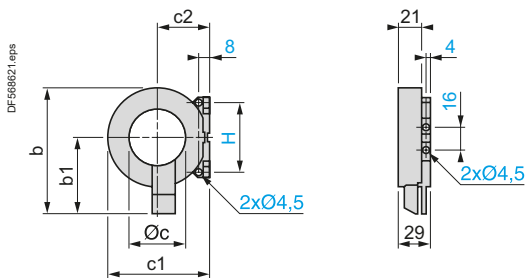

50439, 50440 and 50441

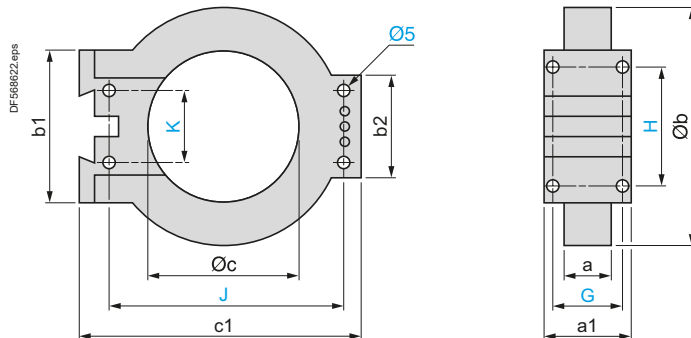

Type	b	b1	Øc	c1	c2	H
50437	83	53	30	60	31	50
50438	109	66	50	87	45	60

Type	a	a1	Øb	b1	b2	Øc	c1	G	H	J	K
50439	26.5	44	122	80	55	80	150	35	65	126	40
50440	26.5	44	164	80	55	120	190	35	65	166	40
50441	29	46	256	120	90	196	274	37	104	254	60

50442

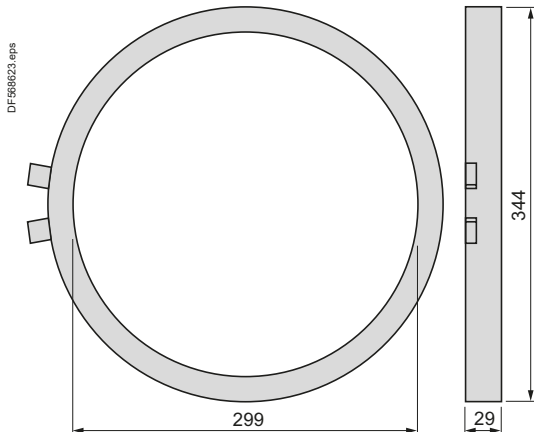

50485 and 50486

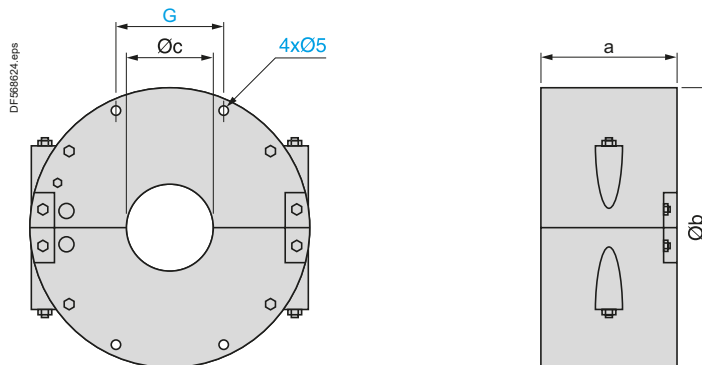

Type	a	Øb	Øc	G
50485	72	148	46	57
50486	78	224	110	76

References:
pages C1/4 to C1/11

Characteristics:
pages C1/20 to C1/34

Curves:
page C1/35

Schemes:
pages C1/38 to C1/41

Schemes

LTMR●●FM wiring with LTM9F filter

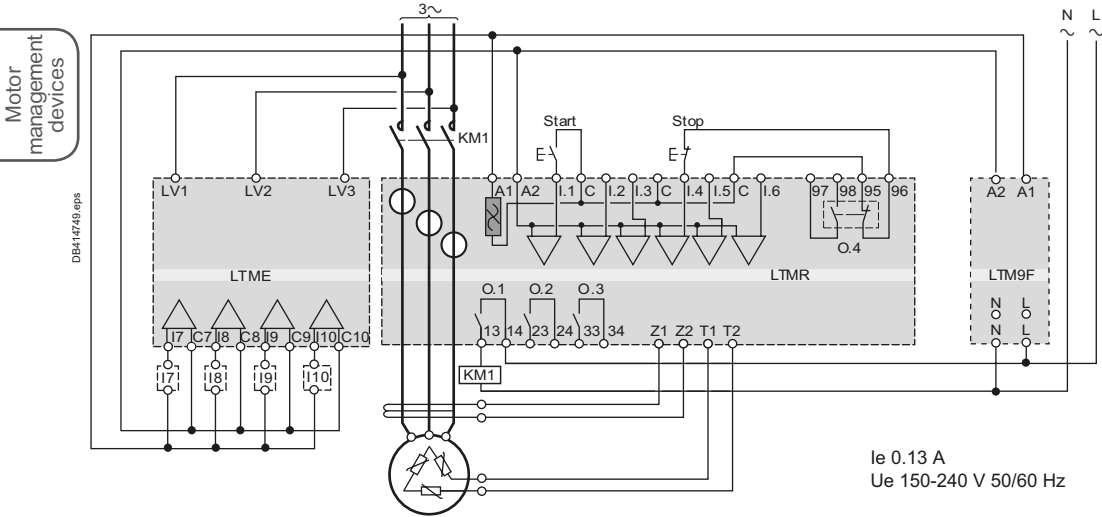

Note: inputs MUST be connected across the common terminals (C).

Overload mode

3-wire local-control

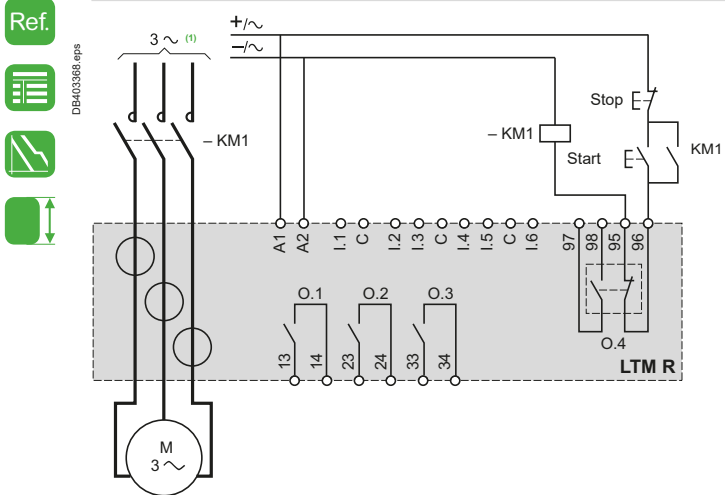

Independent mode

3-wire local-control

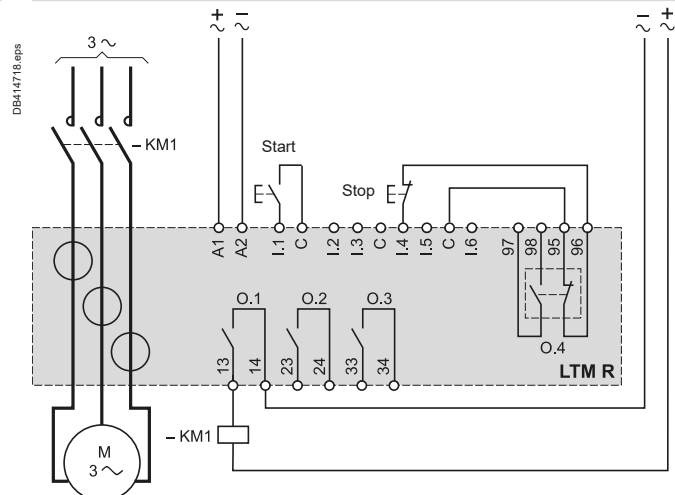

(1) Connection of a single-phase motor is possible. In this case, do not use the central current transformer.

2-wire local-control

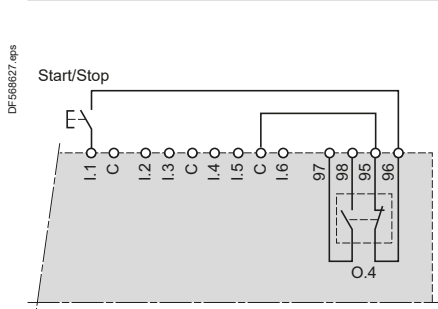

3-wire with switchable local/network control

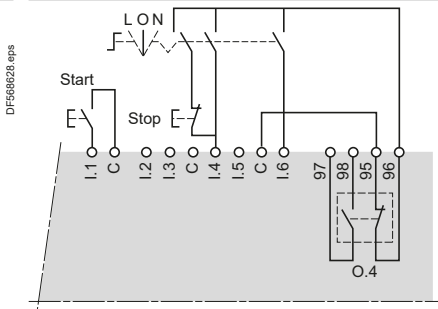

2-wire with switchable local/network control

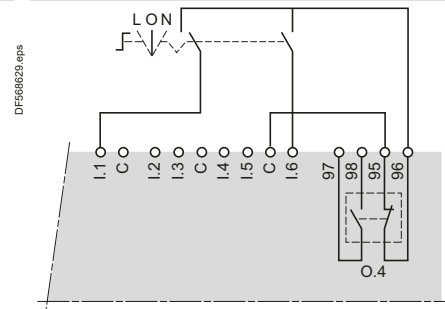

L: Local control
O: Stop
N: Network control

Schemes

Reverser mode

3-wire local-control

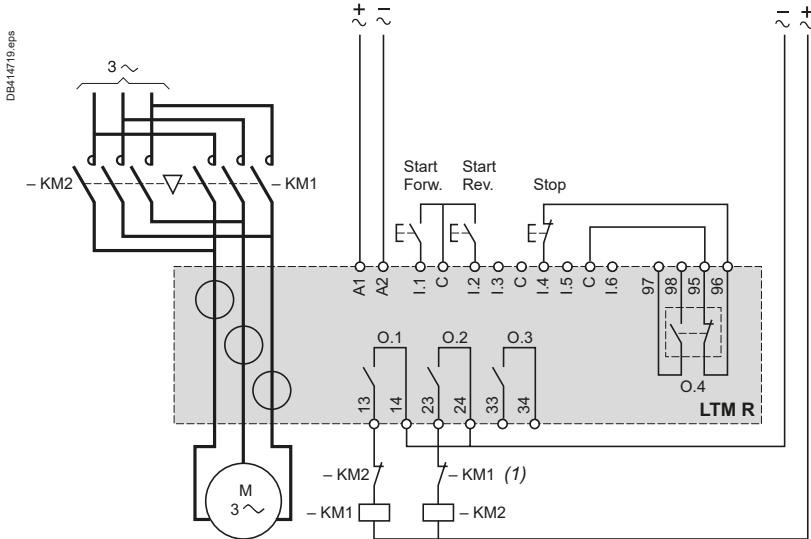

2-step mode, star-delta application

3-wire local-control

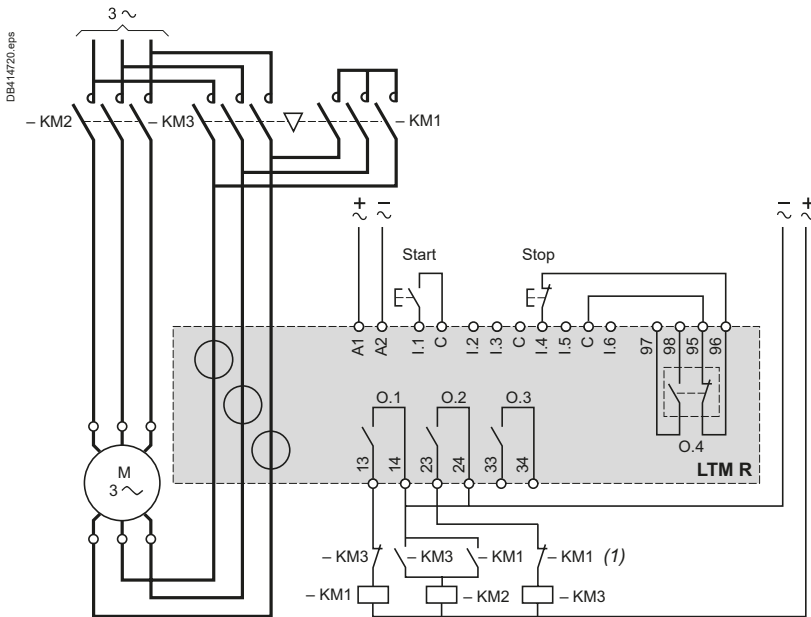

(1) Contacts for interlocking KM1 and KM2 are not obligatory because the controller electronically interlocks outputs O.1 and O.2.

TeSys

TeSys T Motor management system

Schemes

Schemes

2-step mode, primary resistor application

3-wire local-control

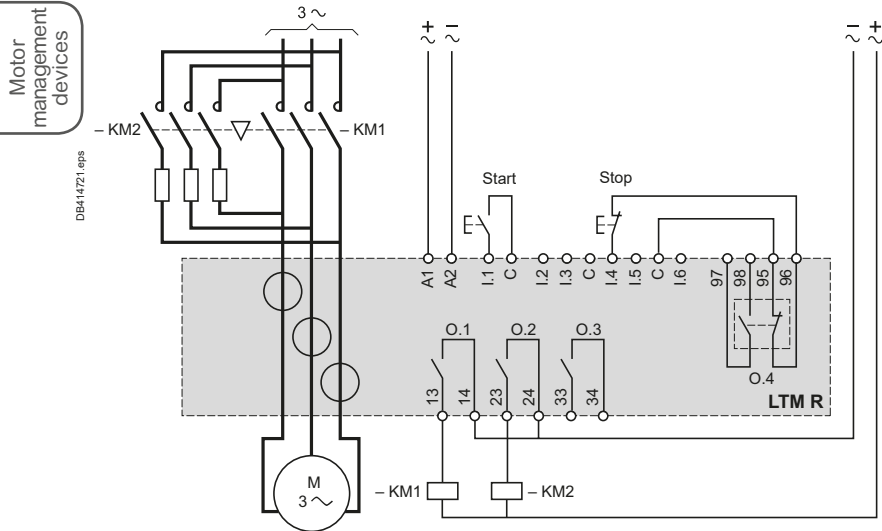

Ref.

2-speed mode, Dahlander application

3-wire local-control

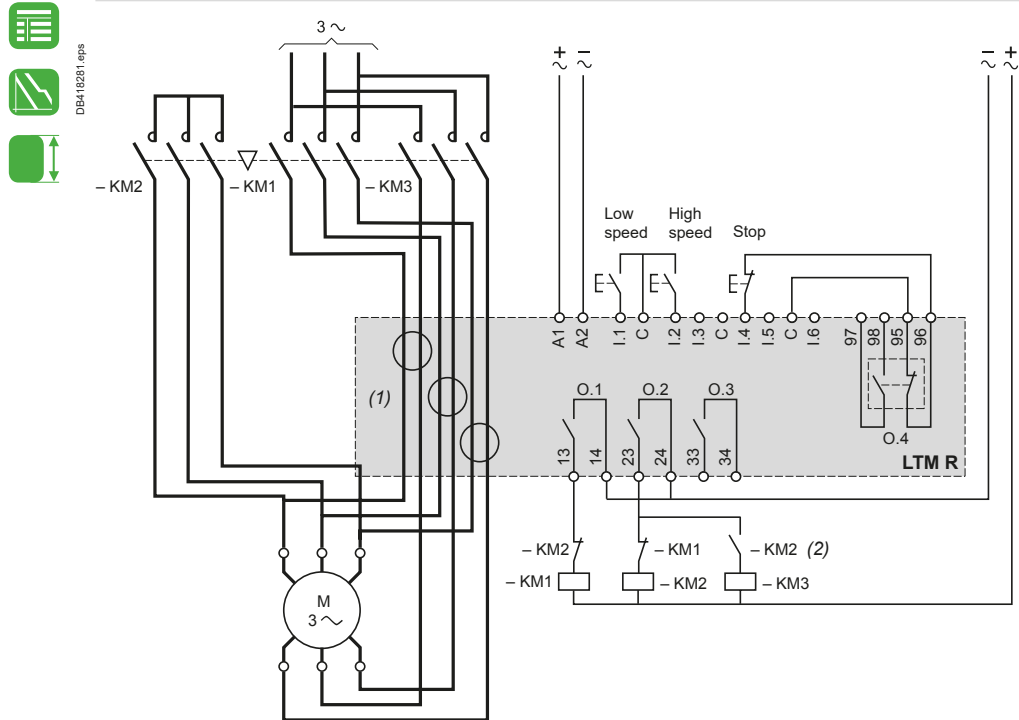

- (1) For a Dahlander application, all the power cables must pass through current transformers. The controller can also be placed upstream of the contactor. In this case, and if the Dahlander motor is used in "variable torque" mode, all the cables downstream of the contactors must be of identical size.
- (2) Contacts for interlocking KM1 and KM2 are not obligatory because the controller electronically interlocks outputs O.1 and O.2.

Schemes

Earth fault toroid and motor temperature probe connection

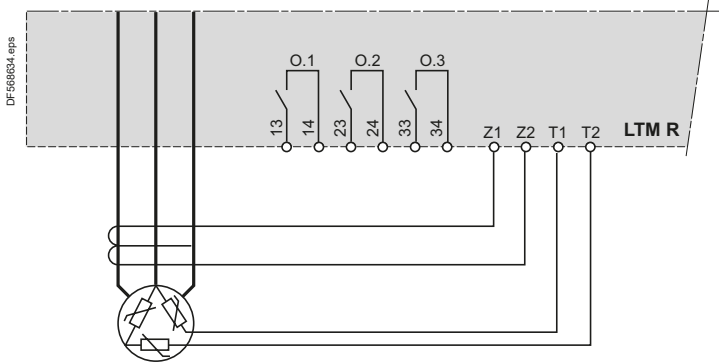

Connection of outputs for motor control mode function

Without intermediate relay

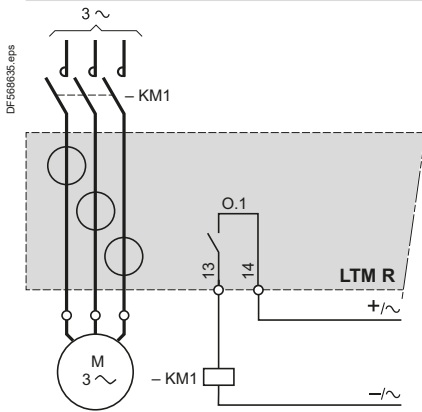

With intermediate relay

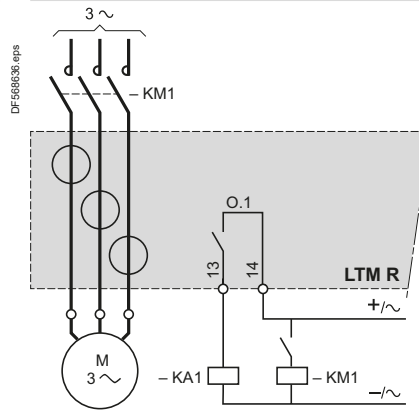

Motor management devices

Ref.



