

# SQUARE D

## Instruction Bulletin

Bulletin No. 50006-419-02

February, 1995

Raleigh, NC, U.S.A.

### Door Mounted Operating Mechanisms Class 9421 Type LG7 For use with Square D Type GJL Circuit Breakers

#### SELECTING KITS

This instruction bulletin contains instructions for assembling and installing Class 9421 Type LG7 door mounted operating mechanisms. Class 9421 Type LG kits contain all components necessary for a complete operating mechanism assembly. The circuit breaker must be purchased separately.

Operating mechanism kits are comprised of a handle, operating mechanism and shaft kit (see Table 1). Individual component kits are available for meeting special application requirements (see Table 2 and Table 3).

**Table 1 Items Included in Type LG1, LG3 and LG4 Kits**

Kit Part No.	Items in Kit		
	Class 9421 Type	Handle Assembly	Operating Mechanism
LG1 <sup>[1]</sup>	LH6	LG7	LS8 <sup>[1]</sup>
LG3	LH3	LG7	LS13
LG4	LH6	LG7	LS13

<sup>[1]</sup>These kits do not include or require a shaft support bracket assembly.

**Table 2 Handle Kits**

Kit Part No.		NEMA Rating	Trip Indication
6" Handle	3-1/2" Handle		
LH6	LH3	1, 3, 3R, 12	Yes
LH46	LH43	4 (painted)	No
LC46	LC43	4 (chrome plated)	No

**Table 3 Shaft Kits**

Shaft	Kit Part No.	Mounting Depth	
		Class 9421 Type	Min.
Standard	LS8	5"	10 3/8"
Long	LS13	5"	21"

**Table 4 Replacement Parts List**

Item	Description	Part No.	Quantity
1	Operating Mechanism	Class 9421 Type LG7	1
2	Handle Assembly	See Table 2	1
3	Shaft	See Table 3	1
4	Shaft Support Bracket (supplied only w/ Type LS13 shaft kit)	Class 9421 Type LS13	1
5	Shaft support Parts Kit: Screw #10-32 x 1/4	31004-674-53	2
6	Handle Parts Kit: Screw 1/4-20 x 3/4 Screw 1/4-20 x 1/2 Washer 1/4 Lockwasher 1/4	30007-500-66	1
7			3
8			3
9			3
10	Mechanism Parts List: Screw #8-32 x 1/2 Screw 1/4-20 x 1 Nut 1/4-20 Lockwasher 1/4	31004-674-51	1
11			2
12			1
13			1
14	Handle Gasket	50002-021-01	1

## INSTALLATION

1. Before beginning installation, read this entire installation section.
2. Open disconnect means ahead of circuit.

# ⚠ DANGER

## HAZARDOUS VOLTAGE.

**Disconnect all power before working on equipment.**

Electrical shock will cause severe injury or death.

3. Remove parts from kit(s). Verify all components listed in Table 4 are included.
4. Determine location of circuit breaker on panel (see Figure 1). Mark, drill and tap hole for two #8-32 x 1/2 mounting screws.
5. Mount the circuit breaker along with the operating mechanism using two 2 x 8-32 x 1/2 screw.
6. Determine enclosure mounting depth (dimension H in Figure 2). Calculate the required shaft length (L) using the formula  $L = H - 2\text{-}1/2"$ . Cut shaft to length L (see Figure 2).

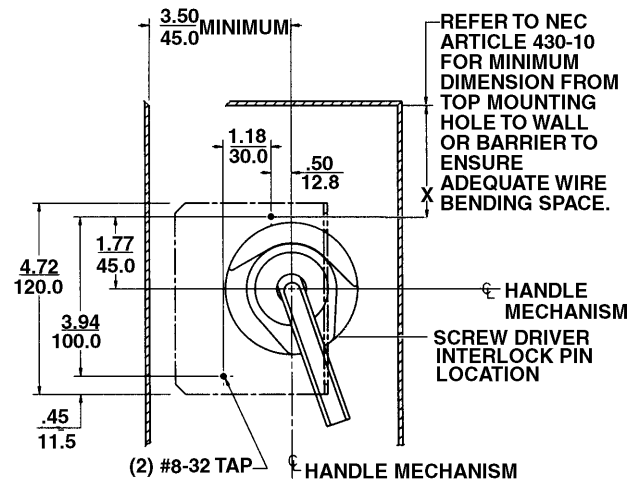
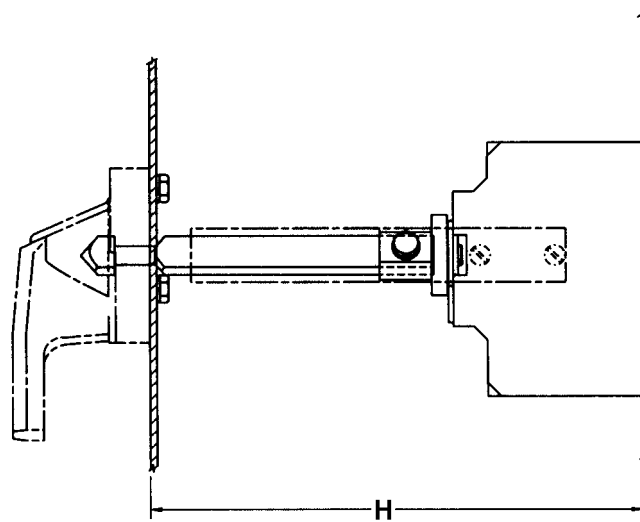

Figure 1 Panel Drilling

7. Insert shaft until it is completely seated in operating mechanism. While holding shaft in place, mark the shaft through the shaft mounting hole. Remove shaft and drill a 9/32" hole through the mark on the shaft.
8. Reinsert shaft into operating mechanism and secure it with screw (1/4-20 x 1), lock washer, washer and nut.
9. **DOOR DRILLING – READ CAREFULLY.**
  - A. When centerline of operating shaft is 12" or greater from door hinge point:
    1. Dab some grease on shaft tip and gently close door until contact is made between the door and shaft tip. The grease marks the center for the 1-3/8" diameter handle mounting hole (see Figure 3 on page 4).
    2. Center punch the grease spot and drill 1/8" diameter pilot hole.
    3. Cut out drilling template (Figure 3).
    4. Center template 1-3/8" diameter hole on pilot hole. Mark and drill holes per template.
  - B. When centerline of operating shaft is less than 12" from door hinge point, locate hole as directed in step 9.A.1. above and move marked hole an additional 1/8" towards door hinge.
  - C. If the cut shaft length is 12" or longer, move the hole DOWN 1/8". This compensates for slight shaft droop due to the weight of the shaft.
10. Mount handle assembly and gasket using self tapping screws, lockwashers and washers. The 6" handle assembly is shown in Figure 1 above. The 3-1/2" handle assembly is shown in Figure 2 on page 3.

*NOTE: If enclosure door thickness is greater than 14 gauge (.075"), use the longer 1/4-20 x 3/4 self-tapping screws.*



**Figure 2 3-1/2" Handle Assembly**

11. If the shaft length is greater than 10", a shaft kit which includes a shaft support bracket must be used.
12. Using the two #10-32 x 1/4" screws supplied, mount the support bracket assembly to the operating mechanism. Do not tighten the screws until proper shaft alignment is attained. Make sure the shaft is free to rotate after the support bracket assembly is mounted. This movement must be checked by turning the shaft to the circuit breaker ON-OFF positions with a suitable wrench. Re-align support bracket assembly if binding is discovered.
13. Turn circuit breaker and handle assembly to OFF position and close door. Handle assembly should easily engage shaft. Check ON-OFF operations. If mechanism binds, check alignment of handle assembly and shaft.

*NOTE: Handle will positively captivate the shaft with a force. This is normal.*

14. Close door and turn handle to ON position. Verify enclosure door cannot be opened with handle and circuit breaker in the ON position.



## **WARNING**

### **HAZARDOUS VOLTAGE.**

**Install operating mechanism so enclosure door cannot be opened with handle and circuit breaker in ON position.**

Failure to observe this precaution can result in severe personal injury or death.

If an authorized person requires access when the handle and circuit breaker are in the "ON" position, the screwdriver interlock pin can be defeated (see Figure 1 on page 2).

15. TEST RESET OPERATION:
  - A. Push trip button on circuit breaker. Circuit breaker should trip.
  - B. Move handle assembly to the TRIPPED position or midway between the OFF and ON positions if the handle is non-trip indicating.
  - C. Close door onto shaft and at the same time rotate the screwdriver interlock pin. The handle assembly should engage shaft, allowing the door to close.
  - D. Move handle assembly to RESET position and test for proper ON-OFF functions.

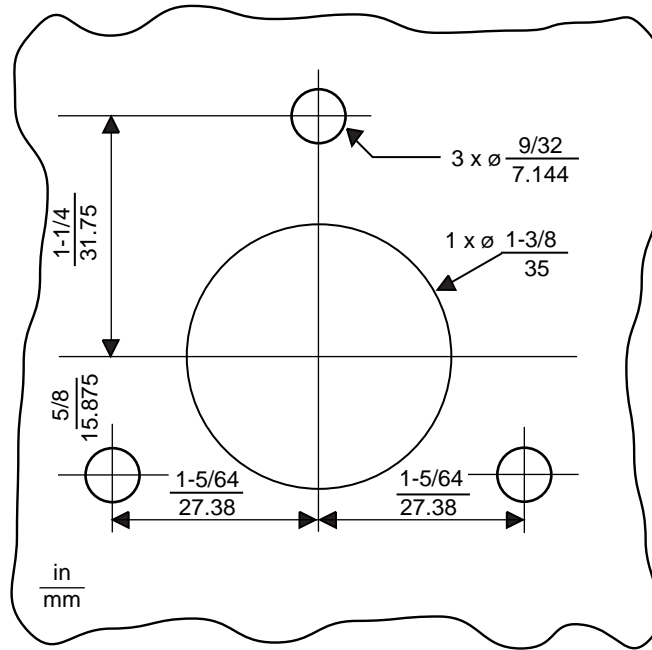

Figure 3 Door Drilling Template (full scale)

**PLEASE NOTE**

Electrical equipment should be serviced only by qualified electrical maintenance personnel, and this document should not be viewed as sufficient instruction for those who are not otherwise qualified to operate, service or maintain the equipment discussed. Although reasonable care has been taken to provide accurate and authoritative information in this document, no responsibility is assumed by Square D for any consequences arising out of the use of this material.