

2 Position Three-Phase Cutout / Arrester Bracket (0°)

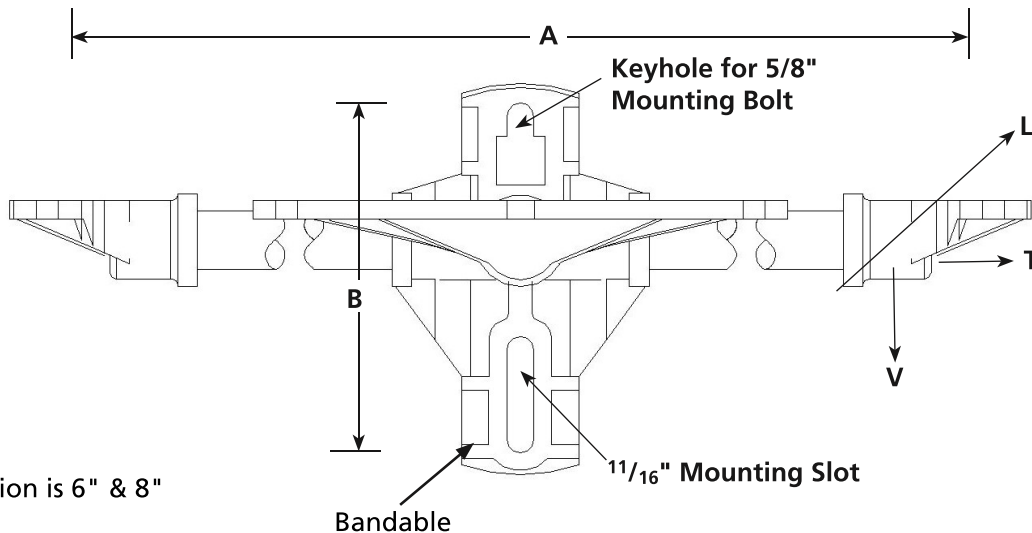

B Dimension is 6" & 8"

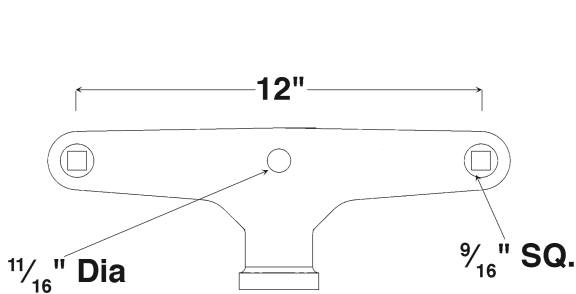

3SBM—CTB Series
includes captive bolt,
nut and washers

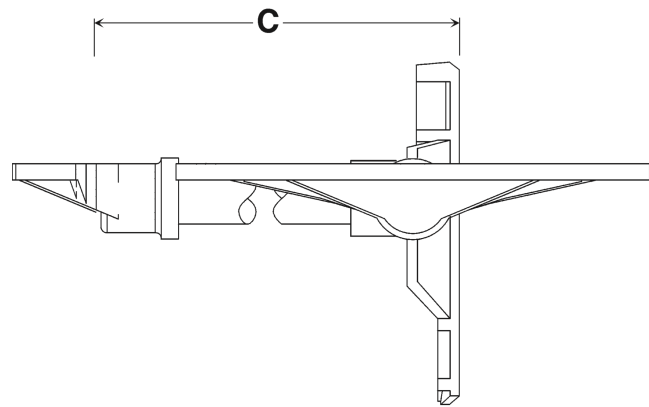

Base and End Fittings are aluminum alloy.

Catalog Number	Length A	Length C	Minimum Ultimate*			Weight (Each)
			Vertical V	Longitudinal L	Transverse T	
Medium Duty 1 1/2" (38 mm) Dia. Fiberglass Rod						
3SBM3613CT	36" (91.4 cm)	13" (33.0 cm)	1200 lbs. (544 kg)	900 lbs. (408 kg)	1500 lbs. (680 kg)	20 lbs. (9.1 kg)
3SBM3618CT	36" (91.4 cm)	18" (45.7 cm)	1200 lbs. (544 kg)	900 lbs. (408 kg)	1500 lbs. (680 kg)	22 lbs. (10.0 kg)
3SBM4813CT	48" (121.9 cm)	13" (33.0 cm)	900 lbs. (408 kg)	700 lbs. (318 kg)	1500 lbs. (680 kg)	23 lbs. (10.4 kg)
3SBM4818CT	48" (121.9 cm)	18" (45.7 cm)	900 lbs. (408 kg)	700 lbs. (318 kg)	1500 lbs. (680 kg)	25 lbs. (11.3 kg)
3SBM3613CTB	36" (91.4 cm)	13" (33.0 cm)	1200 lbs. (544 kg)	900 lbs. (408 kg)	1500 lbs. (680 kg)	20 lbs. (9.0 kg)
3SBM3618CTB	36" (91.4 cm)	18" (45.7 cm)	1200 lbs. (544 kg)	900 lbs. (408 kg)	1500 lbs. (680 kg)	22 lbs. (10.0 kg)
3SBM4813CTB	48" (121.9 cm)	13" (33.0 cm)	900 lbs. (408 kg)	700 lbs. (318 kg)	1500 lbs. (680 kg)	23 lbs. (10.4 kg)
3SBM4818CTB	48" (121.9 cm)	18" (45.7 cm)	900 lbs. (408 kg)	700 lbs. (318 kg)	1500 lbs. (680 kg)	25 lbs. (11.3 kg)

*Recommended maximum working load is 50% of minimum ultimate ratings listed.

Consult factory for additional lengths.

Add "SC" suffix to the end of the catalog number to denote Silicone Coated rod



Phone: 573-682-5521 Email: hpsliterature@hubbell.com Web: hubbellpowersystems.com