



QUALITY PRODUCTS SINCE 1940

HCX SYSTEM

Emergency Lighting Unit and Remote Combinations

LED Emergency Exit Sign
with Side-Mounted Lighting Heads
for Low Profile Installation



HUBBELL LIGHTING, INC.

THE HCX SYSTEM

The HCX is a system of options to provide the best possible solution to emergency lighting situations. With a variety of products controlled from one central source, you can design an effective emergency system that is easy to install and maintain.

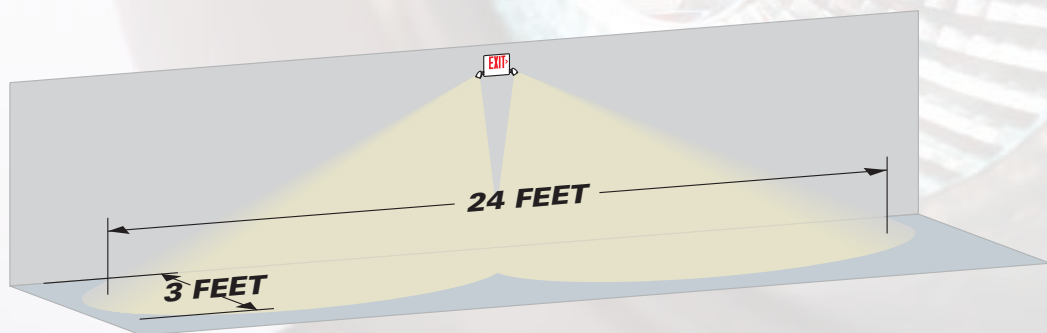

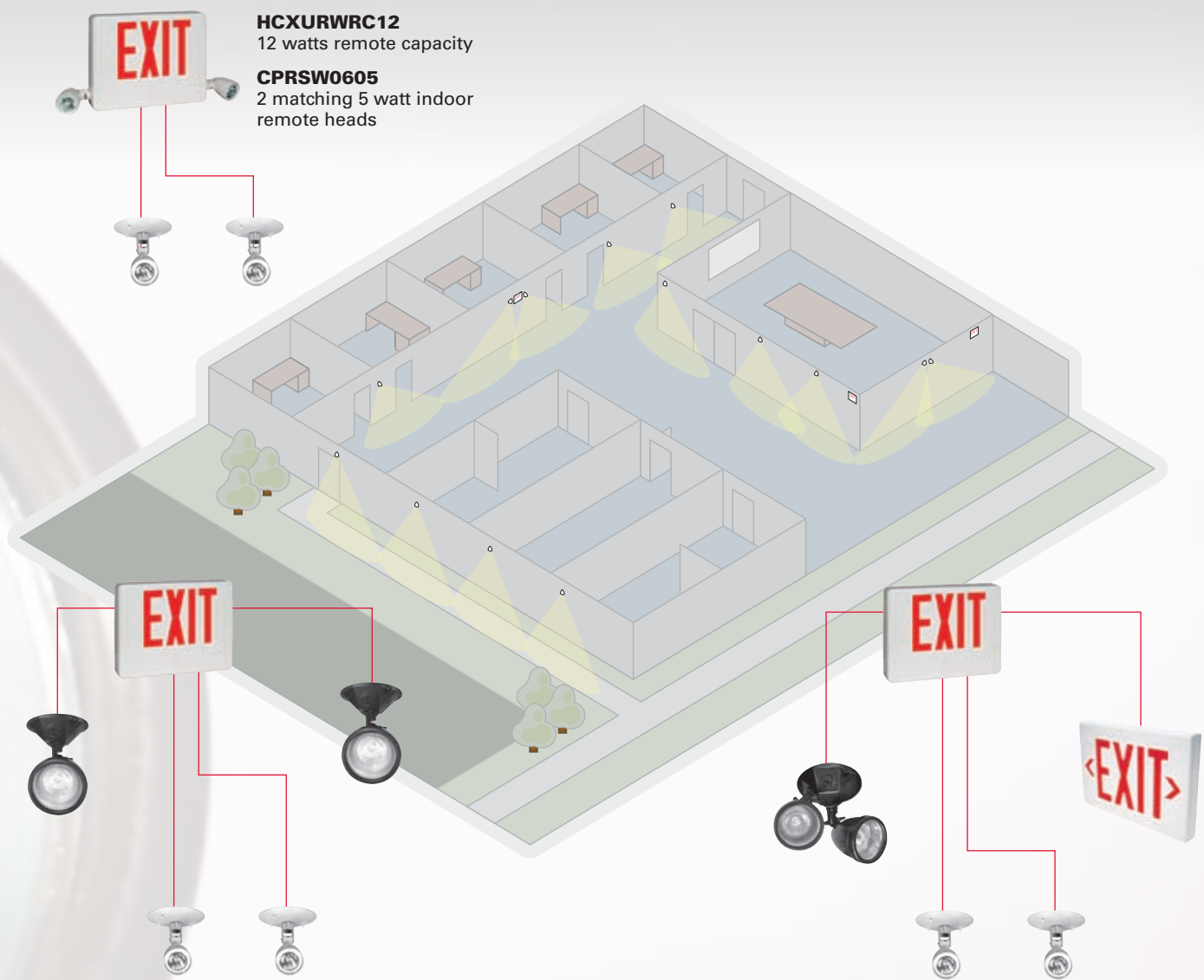

HXCURWRC12
12 watts remote capacity
CPRSW0605
2 matching 5 watt indoor
remote heads

HXCURWRC12
23 watts remote capacity with
integral heads removed
CPRSW0605
2 single matching 5 watt indoor
remote heads
OCRSZ0605
2 single 5 watt outdoor remote heads

HXCURWRC12
23 watts remote capacity with
integral heads removed
CPRSW0605
2 single matching 5 watt
indoor remote heads
OCRDZ0605
1 twin 10 watt outdoor
remote head
LXURW-DC
1 exit sign with -DC option
(3 watt input)



10"

THE HCX SYSTEM

LIGHTING THE PATH TO SAFETY

The job of specifying emergency lighting is critical. Every scenario must be considered – the path to safety well-defined. From an interior office to the gathering place outside the building, the occupants' safety is the primary consideration.

Illuminating the path to safety involves more than just designing a product to meet a code requirement. As the most recognized name in the life safety industry, Dual-Lite accepts this challenge when designing products. That's why HCX System components work well together to provide an exceptional yet cost effective pathway illumination arrangement.

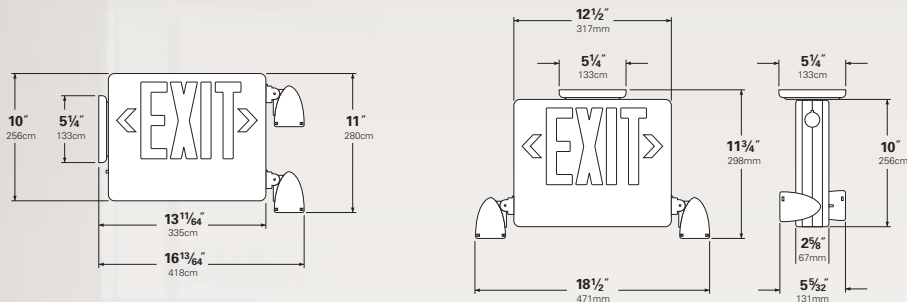

For mounting over doorways with low-ceiling heights, the HCX boasts one of the lowest housing profiles available.

THE INSTALLER'S DREAM

Installing the HCX system is fast and easy. Twist-on fasteners are a thing of the past with the HCX “push-in” wire connectors. Emergency lamps can be easily relocated from side-to-side to facilitate a variety of installations. Housing assembly is a “snap” with no mechanical fasteners. Universal 120/277VAC operation takes out the guesswork of compatibility. The HCX unit is shipped standard with a canopy for ceiling or end mounting.

CONSERVATION – DO YOUR PART

With energy consumption at only 4.5 watts in standby mode, the HCX system offers considerable energy savings. The system meets EPACT 2005 requirements, ensuring low operating cost over the life of the product.

PRIORITY ONE IS SAFETY

The HCX system offers greater visibility in emergency conditions with the high-output MR16 halogen lamps, which provide 33 percent more illumination than incandescent lamps.

COMPONENT DETAILS

VERSATILE

- Emergency lamp heads with full vertical and horizontal rotation allow precise aiming
- Heads are reconfigurable from one on each side to two on a single side
- Low profile housing allows for mounting over doorways with low ceiling heights; fits nicely in tight areas.
- Shipped standard with all components for universal single/double face installation
- Universal wall/ceiling/end mounting. Mounting canopy included standard



BRIGHT

- Diffuser is spectrally matched to the LED wavelength for uniform and enhanced EXIT letter color
- MR16 halogen lamps provide a 33% improvement over comparable wattage incandescent lamps

EFFICIENT

- Advanced LED technology ensures economical operation while maintaining bright even illumination
- Remote capacity models coupled with remote heads offer an extended illumination path powered from a single centralized source
- Maintenance-free battery provides 90-minute emergency operation and never needs water

DURABLE

- Sturdy thermoplastic housing is impact-resistant, UV stable and flame-rated for safety
- Lifetime warranty on LED strip
- Unit components warranty: five full years (excluding battery)
- Battery warranty: 1 year full, 5 years pro-rata

COMPLIANT

- Unit is listed to UL standard 924 (emergency lighting)
- NFPA 101 (Life Safety) Code compliant
- NFPA 70 (National Electrical Code) compliant
- International Building Code (IBC) compliant
- EPACK 2005 compliant
- OCR outdoor remote heads are UL listed for wet location installation



EPACT 2005

PRODUCT SELECTOR

Standard Models
 HCXURW
 HCXUGW
 HCXURB
 HCXUGB

Remote Capacity Models
 HCXURWRC12
 HCXUGWRC12
 HCXURBRC12
 HCXUGBRC12

Letters
 Red
 Green
 Red
 Green

Housing
 White
 White
 Black
 Black



ACCESSORIES (Order Separately)

Wire guard (wall or ceiling mount) 41G

Matching Indoor Remote Heads

CPRSW0605
 Single
 White



CPRDW0605
 Double
 White



CPRSB0605
 Single
 Black



CPRDB0605
 Double
 Black



Matching Outdoor Remote Heads

OCRSW0605
 Single
 White



OCRDW0605
 Double
 White



OCRSB0605
 Single
 Black



OCRDB0605
 Double
 Black



OCRSZ0605
 Single
 Dark Bronze



OCRDZ0605
 Double
 Dark Bronze





Hubbell Lighting, Inc. Life Safety Products • www.dual-lite.com

701 Millennium Boulevard • Greenville, SC 29607

Telephone: 864-678-1000 Fax: 864-678-1415

A Hubbell Lighting, Inc. brand with representatives' offices in principal cities throughout North America.

Copyright Hubbell Lighting, Inc., All Rights Reserved. Specifications subject to change without notice.