

# 225 A Feed-Through Lug Kit Installation onto an NQ Panelboard



**Instalación de un accesorio de  
zapatas de paso de 225 A en un  
tablero de alumbrado NQ**

**Installation du kit de cosses de  
traversée de 225 A dans un panneau  
de distribution NQ**

Instruction Bulletin  
Boletín de instrucciones  
Directives d'utilisation

80043-728-01

**Retain for Future Use.  
Conservar para uso futuro.  
À conserver pour usage ultérieur.**

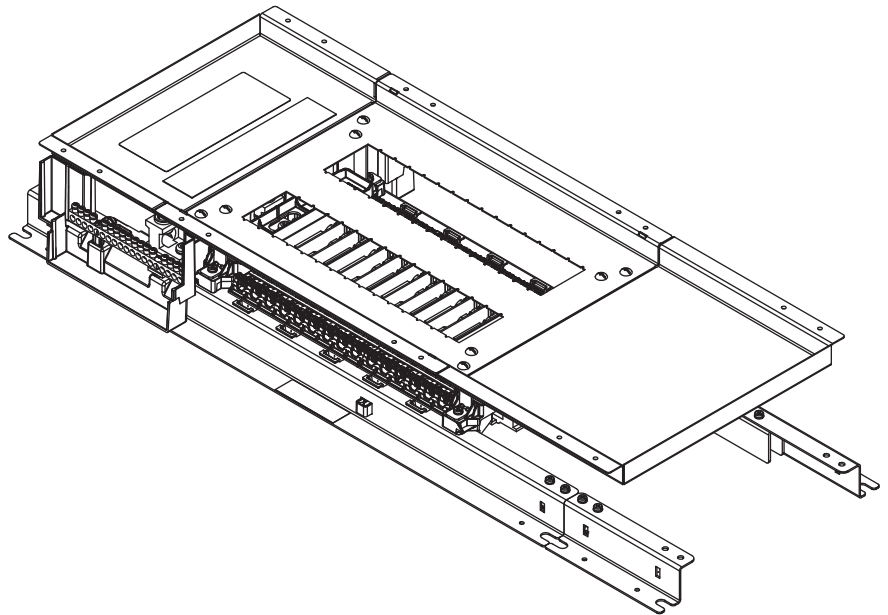



# Instruction Bulletin

## 225 A Feed-Through Lug Kit Installation onto an NQ Panelboard

### Class 1640

Retain for future use.

### Introduction

This bulletin contains instructions for installing a Square D® brand 225 A feed-through lug kit onto a Square D brand NQ panelboard manufactured by Schneider Electric.

### Safety Precautions

#### **⚠ DANGER**

##### HAZARD OF ELECTRIC SHOCK, EXPLOSION, OR ARC FLASH

- Apply appropriate personal protective equipment (PPE) and follow safe electrical work practices. See NFPA 70E.
- This equipment must only be installed and serviced by qualified electrical personnel.
- Turn off all power supplying this equipment before working on or inside equipment.
- Always use a properly rated voltage sensing device to confirm power is off.
- Replace all devices, doors and covers before turning on power to this equipment.

Failure to follow these instructions will result in death or serious injury.

### Kit Contents

#### NQFTL2L and NQFTL2H

- A. Neutral lug (1)
- B. Feed-through lugs (3)
- C. 10-32 x 5/16-inch tapping screws (8)
- D. 1/4-20 x 9/16-inch tapping screw (1)
- E. 1/4-20 x 7/8-inch tapping screws (3)
- F. Rail extensions (2)
- G. Rail splices (2)
- H. Long cover extension (1)
- I. **NQFTL2H kit only**—Short cover extension (1)

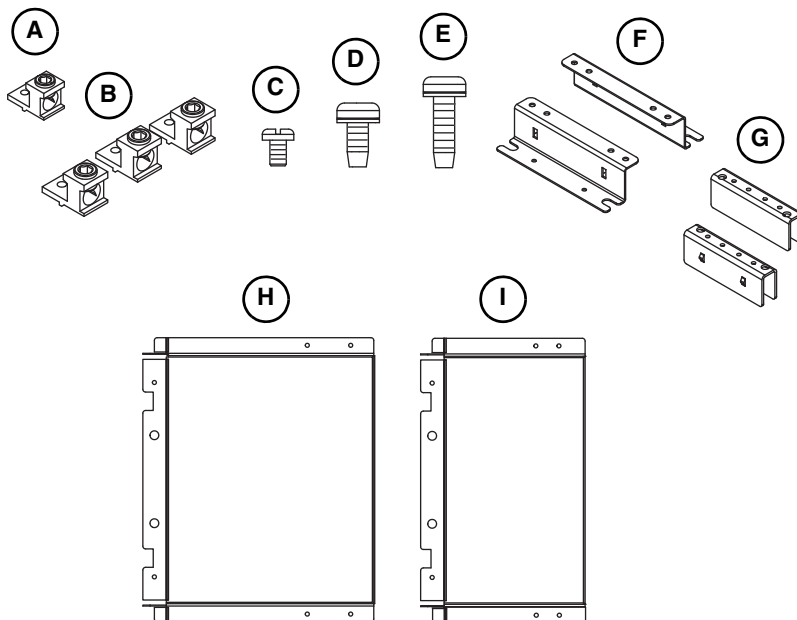

**NOTE:** Screws enlarged to show detail.

### Tools Needed



- #2 Square-head Robertson driver
- Torque wrench with 3/8-inch Allen driver
- Torque wrench with 5/32-inch Allen driver

## Installing the Feed-Through Lug Kit



Turn off all power supplying this equipment before working inside the panelboard; follow all lockout/tagout procedures.

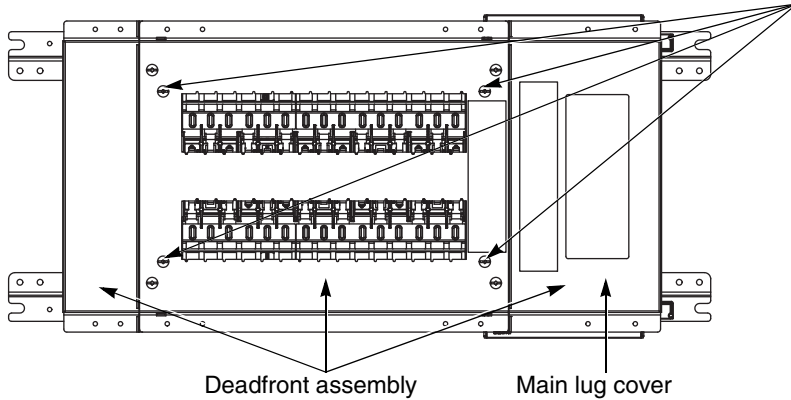

**1** Remove the deadfront assembly. Retain the four screws for reuse.

**NOTE:** For 42-circuit panelboards, step 2 and step 3 are not required. Go to step 4.

**2** Separate the cover extension opposite the mains end. Retain all of the screws and discard the cover extension.

**3** Using the screws from step 2, attach the cover extension supplied with the kit to the deadfront assembly, opposite the mains end, as shown in the graphic. Also refer to Table 1 below.

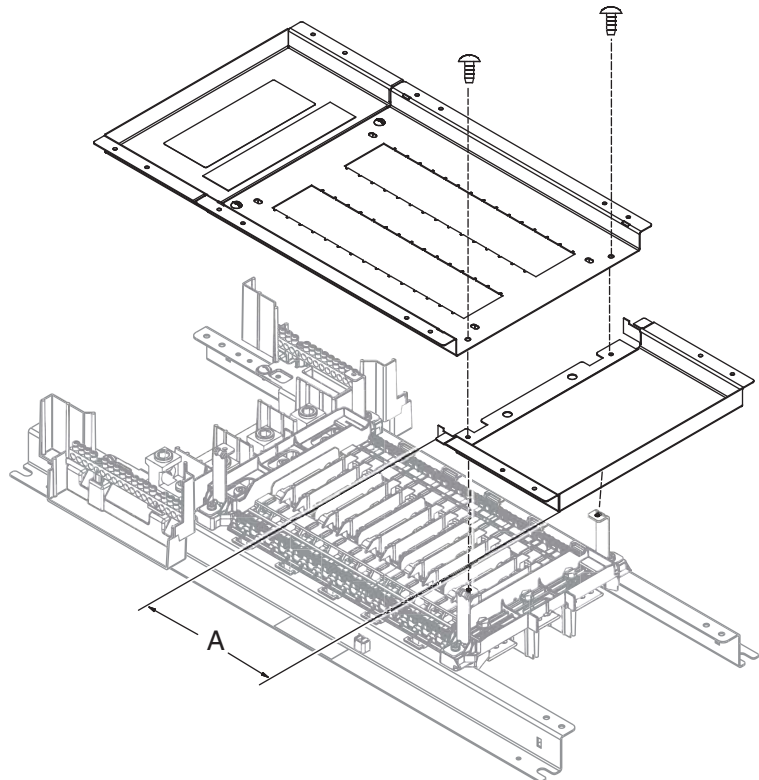

**Table 1: Cover Extension Selection**

Circuits	Kit Catalog No.	Cover Length—Dimension A
30	NQFTL2L	10.05 inches (255 mm)
54 and 72	NQFTL2H	7.08 inches (180 mm)
84	NQFTL2H	8.58 inches (218 mm)

**4** Discard any unused cover extensions included in the kit.

**5 NOTE: Do not overtighten the screws.**

Install the feed-through lugs included in the kit onto the ends of the panel bus bars, opposite the mains end, using the 1/4-20 x 7/8-inch tapping screws included in the kit. Tighten to 25–30 lb-in (2.8–3.4 N•m).

**NOTE:** Middle lug is installed for three-phase panels only.

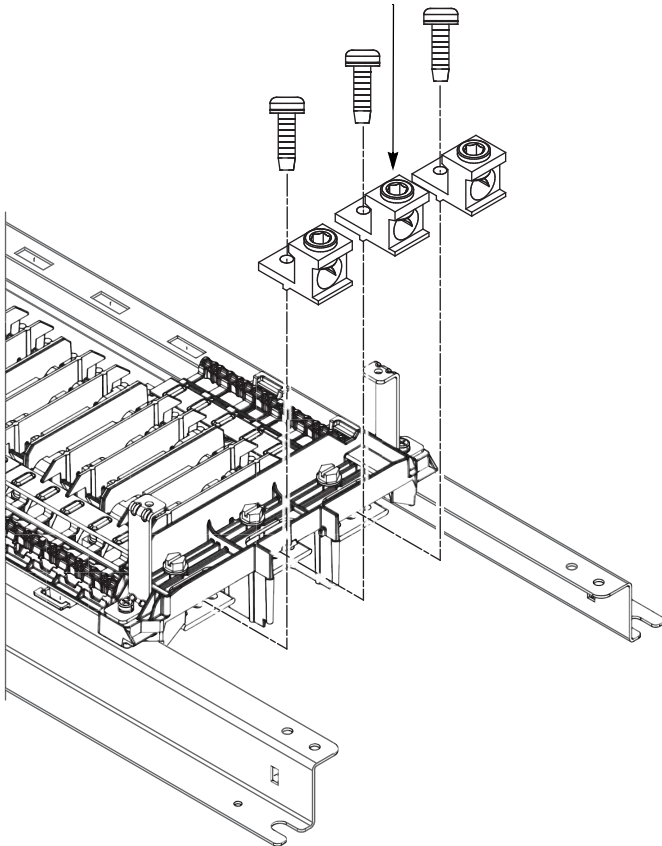

**225 A Lugs Installed**

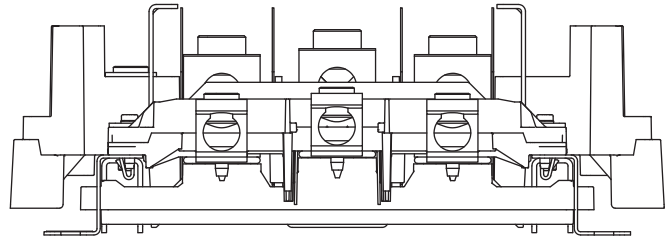

**6** Install the neutral lug included in the kit to the neutral bar using one 1/4-20 x 9/16-inch tapping screw included in the kit. Tighten to 25–30 lb-in (2.8–3.4 N•m).

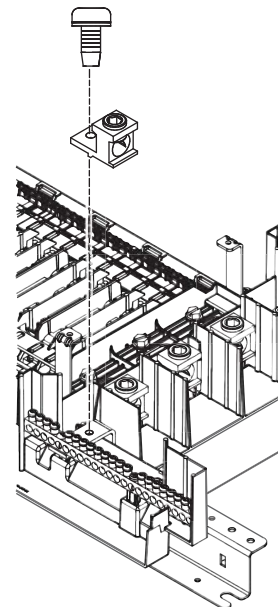

- 7 Install the rail extensions to the end of the existing mounting rail, opposite the mains end, using rail splices and eight 10-32 x 5/16-inch tapping screws included in the kit.

**NOTE:** For 42-circuit panelboards, the rail extensions, rail splices, and eight 10-32 x 5/16-inch screws are not required and should be discarded.

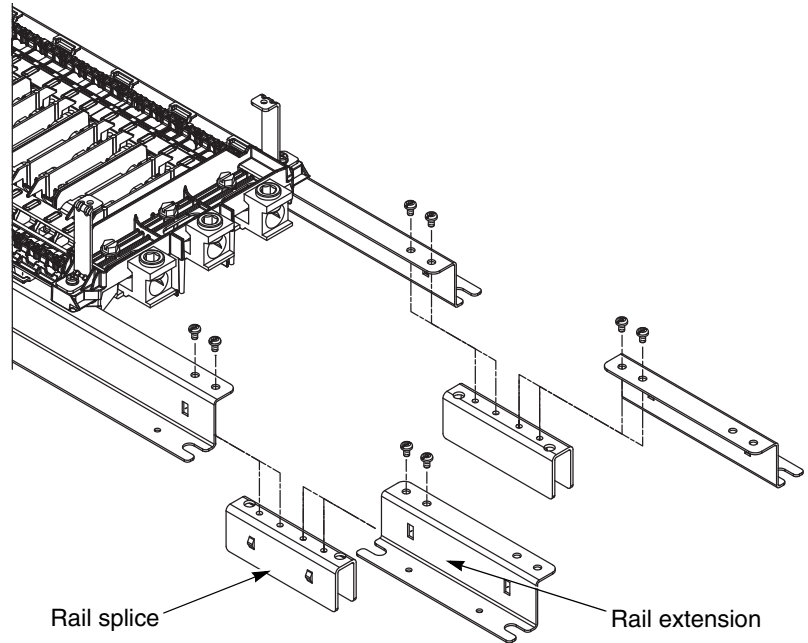

- 8 Remount the deadfront assembly using the screws retained from step 1.

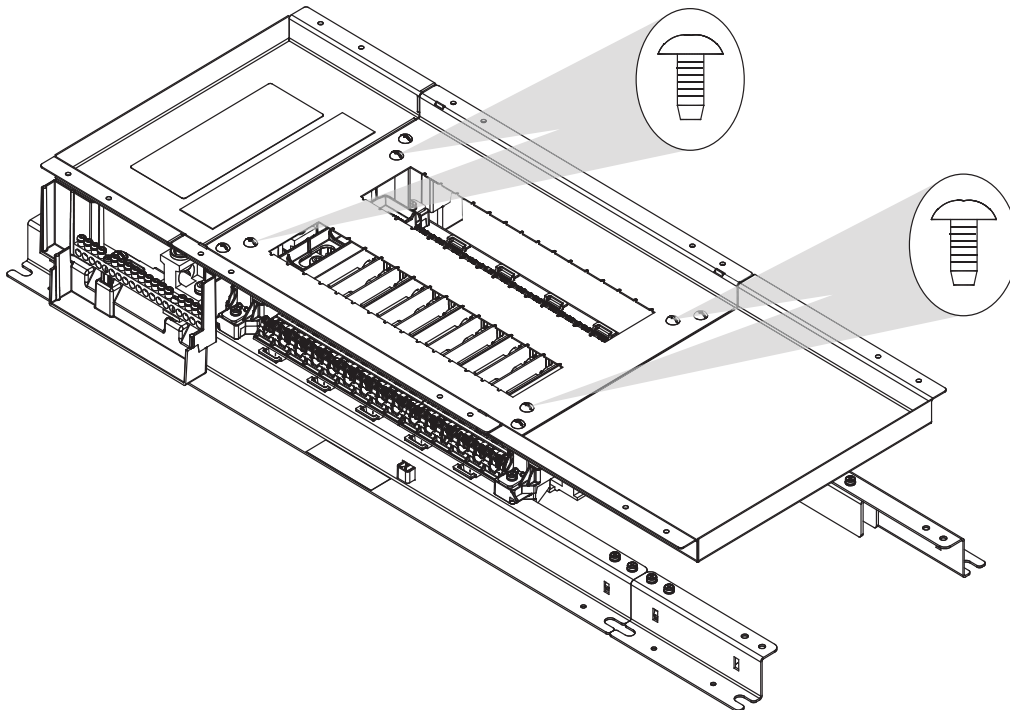

For technical support on the installation of this kit, contact the Square D/Schneider Electric Customer Information Center at 1-888-SquareD (1-888-778-2733).

Schneider Electric USA  
252 North Tippecanoe  
Peru, IN 46970 USA  
1-888-SquareD (1-888-778-2733)  
www.us.SquareD.com

Electrical equipment should be installed, operated, serviced, and maintained only by qualified personnel. No responsibility is assumed by Schneider Electric for any consequences arising out of the use of this material.

© 2008 Schneider Electric All Rights Reserved



# California Proposition 65 Warning—Nickel Compounds and Bisphenol A (BPA)

## Advertencia de la Proposición 65 de California— compuestos de níquel y Bisfenol A (BPA)

## Avertissement concernant la Proposition 65 de Californie— composés de nickel et Bisphénol A (BPA)

**⚠️ WARNING:** This product can expose you to chemicals including Nickel compounds, which are known to the State of California to cause cancer, and Bisphenol A (BPA), which is known to the State of California to cause birth defects or other reproductive harm. For more information go to [www.P65Warnings.ca.gov](http://www.P65Warnings.ca.gov).

**⚠️ ADVERTENCIA:** Este producto puede exponerle a químicos incluyendo compuestos de níquel, que son conocidos por el Estado de California como causantes de cáncer, y Bisfenol A (BPA), que es conocido por el Estado de California como causante de defectos de nacimiento u otros daños reproductivos. Para mayor información, visite [www.P65Warnings.ca.gov](http://www.P65Warnings.ca.gov).

**⚠️ AVERTISSEMENT:** Ce produit peut vous exposer à des agents chimiques, y compris composés de nickel, identifiés par l'État de Californie comme pouvant causer le cancer, et Bisphénol A (BPA) reconnu par l'État de Californie comme pouvant causer des malformations congénitales ou autres troubles de l'appareil reproducteur. Pour de plus amples informations, prière de consulter [www.P65Warnings.ca.gov](http://www.P65Warnings.ca.gov).

All trademarks are the property of Schneider Electric SE, its subsidiaries, and affiliated companies.

**Schneider Electric USA, Inc.**  
800 Federal Street  
Andover, MA 01810 USA  
888-778-2733  
[www.schneider-electric.us](http://www.schneider-electric.us)

Todas las marcas comerciales son propiedad de Schneider Electric SE, sus filiales y compañías afiliadas.

Importado en México por:  
**Schneider Electric México, S.A. de C.V.**  
Av. Ejercito Nacional No. 904  
Col. Palmas, Polanco 11560 México, D.F.  
55-5804-5000  
[www.schneider-electric.com.mx](http://www.schneider-electric.com.mx)

Toutes les marques commerciales sont la propriété de Schneider Electric SE, ses filiales et compagnies affiliées.

**Schneider Electric Canada, Inc.**  
5985 McLaughlin Road  
Mississauga, ON L5R 1B8 Canada  
800-565-6699  
[www.schneider-electric.ca](http://www.schneider-electric.ca)