

Modicon TM2

Digital I/O Modules

Hardware Guide

06/2011



E100000000028.05

www.schneider-electric.com

Schneider
Electric

The information provided in this documentation contains general descriptions and/or technical characteristics of the performance of the products contained herein. This documentation is not intended as a substitute for and is not to be used for determining suitability or reliability of these products for specific user applications. It is the duty of any such user or integrator to perform the appropriate and complete risk analysis, evaluation and testing of the products with respect to the relevant specific application or use thereof. Neither Schneider Electric nor any of its affiliates or subsidiaries shall be responsible or liable for misuse of the information contained herein. If you have any suggestions for improvements or amendments or have found errors in this publication, please notify us.

No part of this document may be reproduced in any form or by any means, electronic or mechanical, including photocopying, without express written permission of Schneider Electric.

All pertinent state, regional, and local safety regulations must be observed when installing and using this product. For reasons of safety and to help ensure compliance with documented system data, only the manufacturer should perform repairs to components.

When devices are used for applications with technical safety requirements, the relevant instructions must be followed.

Failure to use Schneider Electric software or approved software with our hardware products may result in injury, harm, or improper operating results.

Failure to observe this information can result in injury or equipment damage.

© 2011 Schneider Electric. All rights reserved.

Table of Contents

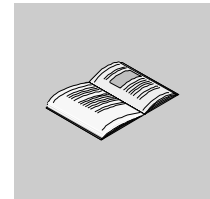

	Safety Information	7
	About the Book	9
Chapter 1	General Overview and Rules for Implementing	13
1.1	General Overview	14
	General Description	15
	Physical description	17
	Accessories	18
1.2	General Rules for Implementing	20
	Mounting Positions and Minimum Clearances	21
	Assembling a Module to a Controller	22
	Disassembling a Module from a Controller	24
	How to Install and Remove the Controller with its Expansions from Mounting Rail	25
	How to Directly Mount a Module on a Panel Surface	27
	Wiring Requirements	28
Chapter 2	Environmental Characteristics of TM2 I/O Modules ...	35
	Environmental Characteristics of TM2 I/O Modules	35
Chapter 3	TM2DAI8DT Digital Input Module	37
	Presentation of the TM2DAI8DT Module	38
	Characteristics of the TM2DAI8DT Module	39
	Connecting the TM2DAI8DT Module	41
Chapter 4	TM2DDI8DT Digital Input Module	43
	Presentation of the TM2DDI8DT Module	44
	Characteristics of the TM2DDI8DT Module	45
	Connecting the TM2DDI8DT Module	48
Chapter 5	TM2DDI16DT Digital Input Module	49
	Presentation of the TM2DDI16DT Module	50
	Characteristics of the TM2DDI16DT Module	51
	Connecting the TM2DDI16DT Module	53
Chapter 6	TM2DDI16DK Digital Input Module	55
	Presentation of the TM2DDI16DK Module	56
	Characteristics of the TM2DDI16DK Module	57
	Connecting the TM2DDI16DK Module	59

Chapter 7	TM2DDI32DK Digital Input Module	61
	Presentation of the TM2DDI32DK Module.	62
	Characteristics of the TM2DDI32DK Module.	63
	Connecting the TM2DDI32DK Module.	65
Chapter 8	TM2DRA8RT Digital Relay Output Module	67
	Presentation of the TM2DRA8RT Module.	68
	Characteristics of the TM2DRA8RT Module.	69
	Connecting the TM2DRA8RT Module.	72
Chapter 9	TM2DRA16RT Digital Relay Output Module	73
	Presentation of the TM2DRA16RT Module.	74
	Characteristics of the TM2DRA16RT Module.	75
	Connecting the TM2DRA16RT Module.	78
Chapter 10	TM2DDO8UT Digital Transistor Output Module	81
	Presentation of the TM2DDO8UT Module.	82
	Characteristics of the TM2DDO8UT Module.	83
	Connecting the TM2DDO8UT Module.	85
Chapter 11	TM2DDO8TT Digital Transistor Output Module	87
	Presentation of the TM2DDO8TT Module.	88
	Characteristics of the TM2DDO8TT Module.	89
	Connecting the TM2DDO8TT Module.	91
Chapter 12	TM2DDO16UK Digital Transistor Output Module	93
	Presentation of the TM2DDO16UK Module.	94
	Characteristics of the TM2DDO16UK Module.	95
	Connecting the TM2DDO16UK Module.	97
Chapter 13	TM2DDO16TK Digital Transistor Output Module	99
	Presentation of the TM2DDO16TK Module.	100
	Characteristics of the TM2DDO16TK Module.	101
	Connecting the TM2DDO16TK Module.	103
Chapter 14	TM2DDO32UK Digital Transistor Output Module	105
	Presentation of the TM2DDO32UK Module.	106
	Characteristics of the TM2DDO32UK Module.	107
	Connecting the TM2DDO32UK Module.	109
Chapter 15	TM2DDO32TK Digital Transistor Output Module	111
	Presentation of the TM2DDO32TK Module.	112
	Characteristics of the TM2DDO32TK Module.	113
	Connecting the TM2DDO32TK Module.	115
Chapter 16	TM2DMM8DRT Digital Mixed I/O Module	117
	Presentation of the TM2DMM8DRT Module.	118
	Characteristics of the TM2DMM8DRT Module.	119
	Connecting the TM2DMM8DRT Module.	123

Chapter 17	TM2DMM24DRF Digital Mixed I/O Module	125
	Presentation of the TM2DMM24DRF Module	126
	Characteristics of the TM2DMM24DRF Module	127
	Connecting the TM2DMM24DRF Module	132
Chapter 18	Certifications and Standards	133
	Certifications and Standards	133
Glossary	135
Index	141

Safety Information

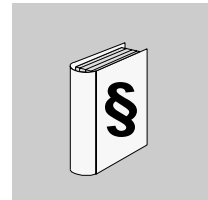

Important Information

NOTICE

Read these instructions carefully, and look at the equipment to become familiar with the device before trying to install, operate, or maintain it. The following special messages may appear throughout this documentation or on the equipment to warn of potential hazards or to call attention to information that clarifies or simplifies a procedure.



The addition of this symbol to a Danger or Warning safety label indicates that an electrical hazard exists, which will result in personal injury if the instructions are not followed.



This is the safety alert symbol. It is used to alert you to potential personal injury hazards. Obey all safety messages that follow this symbol to avoid possible injury or death.

DANGER

DANGER indicates an imminently hazardous situation which, if not avoided, **will result in** death or serious injury.

WARNING

WARNING indicates a potentially hazardous situation which, if not avoided, **can result in** death or serious injury.

 **CAUTION**

CAUTION indicates a potentially hazardous situation which, if not avoided, **can result in** minor or moderate injury.

CAUTION

CAUTION, used without the safety alert symbol, indicates a potentially hazardous situation which, if not avoided, **can result in** equipment damage.

PLEASE NOTE

Electrical equipment should be installed, operated, serviced, and maintained only by qualified personnel. No responsibility is assumed by Schneider Electric for any consequences arising out of the use of this material.

A qualified person is one who has skills and knowledge related to the construction and operation of electrical equipment and its installation, and has received safety training to recognize and avoid the hazards involved.

About the Book

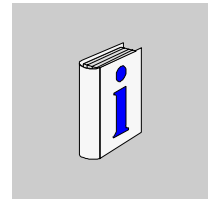

At a Glance

Document Scope

This guide describes the hardware implementation of TM2 digital I/O expansion modules. It provides parts descriptions, characteristics, wiring diagrams, installation, and setup for TM2 digital I/O expansion modules.

Validity Note

The information in this manual is applicable **only** for TM2 products.

This document has been updated with the release of SoMachine V3.0.

The technical characteristics of the device(s) described in this manual also appear online. To access this information online:

Step	Action
1	Go to the Schneider Electric home page www.schneider-electric.com .
2	In the Search box type the model number of a product or the name of a product range. <ul style="list-style-type: none">● Do not include blank spaces in the model number/product range.● To get information on a grouping similar modules, use asterisks (*).
3	If you entered a model number, go to the Product datasheets search results and click on the model number that interests you. If you entered the name of a product range, go to the Product Ranges search results and click on the product range that interests you.
4	If more than one model number appears in the Products search results, click on the model number that interests you.
5	Depending on the size of your screen, you may need to scroll down to see the data sheet.
6	To save or print a data sheet as a .pdf file, click Download XXX product datasheet .

The characteristics presented in this manual should be the same as those that appear online. In line with our policy of constant improvement we may revise content over time to improve clarity and accuracy. In the event that you see a difference between the manual and online information, use the online information as your reference.

Related Documents

Title of Documentation	Reference Number
Modicon TM2 Expansion Modules Configuration Programming Guide	EIO0000000396 (ENG); EIO0000000397 (FRE); EIO0000000398 (GER); EIO0000000399 (SPA); EIO0000000400 (ITA); EIO0000000401 (CHS)
Modicon M238 Logic Controller Hardware Guide	EIO0000000016 (ENG); EIO0000000017 (FRE); EIO0000000018 (GER); EIO0000000019 (SPA); EIO0000000020 (ITA); EIO0000000021 (CS)
TM2 Digital I/O Modules Instruction Sheet	AAV81773

You can download these technical publications and other technical information from our website at www.schneider-electric.com.

Product Related Information

DANGER

HAZARD OF ELECTRIC SHOCK, EXPLOSION OR ARC FLASH

- Disconnect all power from all equipment including connected devices prior to removing any covers or doors, or installing or removing any accessories, hardware, cables, or wires except under the specific conditions specified in the appropriate hardware guide for this equipment.
- Always use a properly rated voltage sensing device to confirm the power is off where and when indicated.
- Replace and secure all covers, accessories, hardware, cables, and wires and confirm that a proper ground connection exists before applying power to the unit.
- Use only the specified voltage when operating this equipment and any associated products.

Failure to follow these instructions will result in death or serious injury.

DANGER

EXPLOSIVE POTENTIAL

- Only use this equipment in non-hazardous locations, or in locations that comply with Class I, Division 2, Groups A, B, C and D.
- Do not substitute components which would impair compliance to Class I Division 2.
- Do not connect or disconnect equipment unless power has been removed or the location is known to be non-hazardous.

Failure to follow these instructions will result in death or serious injury.

WARNING

LOSS OF CONTROL

- The designer of any control scheme must consider the potential failure modes of control paths and, for certain critical control functions, provide a means to achieve a safe state during and after a path failure. Examples of critical control functions are emergency stop and overtravel stop, power outage and restart.
- Separate or redundant control paths must be provided for critical control functions.
- System control paths may include communication links. Consideration must be given to the implications of unanticipated transmission delays or failures of the link.
- Observe all accident prevention regulations and local safety guidelines.¹
- Each implementation of this equipment must be individually and thoroughly tested for proper operation before being placed into service.

Failure to follow these instructions can result in death, serious injury, or equipment damage.

¹ For additional information, refer to NEMA ICS 1.1 (latest edition), "Safety Guidelines for the Application, Installation, and Maintenance of Solid State Control" and to NEMA ICS 7.1 (latest edition), "Safety Standards for Construction and Guide for Selection, Installation and Operation of Adjustable-Speed Drive Systems" or their equivalent governing your particular location.

WARNING

UNINTENDED EQUIPMENT OPERATION

- Only use software approved by Schneider Electric for use with this equipment.
- Update your application program every time you change the physical hardware configuration.

Failure to follow these instructions can result in death, serious injury, or equipment damage.

User Comments

We welcome your comments about this document. You can reach us by e-mail at techcomm@schneider-electric.com.

General Overview and Rules for Implementing

1

Introduction

This chapter gives a general introduction and the rules for implementing the modules.

What's in this Chapter?

This chapter contains the following sections:

Section	Topic	Page
1.1	General Overview	14
1.2	General Rules for Implementing	20

1.1 General Overview

Introduction

This section gives a general introduction to the modules.

What's in this Section?

This section contains the following topics:

Topic	Page
General Description	15
Physical description	17
Accessories	18

General Description

Introduction

The range of TM2 I/O modules includes

- Input modules,
- Output modules,
- Mixed input/output modules.

The TM2 digital I/O modules are equipped with either a HE10 connector, a non removable spring terminal block or a removable screw terminal block. For modules fitted with HE10 type connector outputs, a group of products known as Telefast 2 are available that enable digital input/output modules to be quickly connected to sensors and actuators (Please refer to Telefast 2 catalog for more information).

Module Features

The following table shows the digital I/O modules features, with corresponding channel type, voltage/current and terminal type:

Reference module	Channels	Channel type	Voltage/current	Terminal type	Reference page
Input Modules					
TM2DAI8DT	8	Inputs	120 Vac 7.5 mA	Removable screw terminal block	TM2DAI8DT (see page 37)
TM2DDI8DT	8	Inputs	24 Vdc 7 mA	Removable screw terminal block	TM2DDI8DT (see page 43)
TM2DDI16DT	16	Inputs	24 Vdc 7 mA	Removable screw terminal block	TM2DDI16DT (see page 49)
TM2DDI16DK	16	Inputs	24 Vdc 5 mA	HE10 Connector	TM2DDI16DK (see page 55)
TM2DDI32DK	32	Inputs	24 Vdc 5 mA	HE10 Connector	TM2DDI32DK (see page 61)
Output Modules					
TM2DRA8RT	8	Outputs Relay	30 Vdc/230 Vac 2 A max	Removable screw terminal block	TM2DRA8RT (see page 67)
TM2DRA16RT	16	Outputs Relay	30 Vdc/230 Vac 2 A max	Removable screw terminal block	TM2DRA16RT (see page 73)
TM2DDO8UT	8	Outputs Transistor sink	24 Vdc 0.3 A max per output	Removable screw terminal block	TM2DDO8UT (see page 81)
TM2DDO8TT	8	Outputs Transistor source	24 Vdc 0.5 A max per output	Removable screw terminal block	TM2DDO8TT (see page 87)

Reference module	Channels	Channel type	Voltage/current	Terminal type	Reference page
TM2DDO16UK	16	Outputs Transistor sink	24 Vdc 0.1 A max per output	HE10 Connector	TM2DDO16UK (see page 93)
TM2DDO16TK	16	Outputs Transistor source	24 Vdc 0.4 A max per output	HE10 Connector	TM2DDO16TK (see page 99)
TM2DDO32UK	32	Outputs Transistor sink	24 Vdc 0.1 A max per output	HE10 Connector	TM2DDO32UK (see page 105)
TM2DDO32TK	32	Outputs Transistor source	24 Vdc 0.4 A max per output	HE10 Connector	TM2DDO32TK (see page 111)
Mixed Modules					
TM2DMM8DRT	4 4	Inputs Outputs Relay	24 Vdc/7 mA 30 Vdc/230 Vac 2 A max	Removable screw terminal block	TM2DMM8DRT (see page 117)
TM2DMM24DRF	16 8	Inputs Outputs Relay	24 Vdc/7 mA 30 Vdc/230 Vac 2 A max	Non-removable spring terminal block	TM2DMM24DRF (see page 125)

Physical description

Introduction

This section describes the parts of 3 digital I/O modules, one with a HE10 connector, one with a removable screw terminal block and one with a non removable spring terminal block. In general, the modules with a HE10 connector have a reference ending in K whereas the modules with a terminal block have a reference ending in T. Your I/O module may differ from the illustrations but the parts will be the same.

Illustration

The following pictures show the parts of the 3 digital I/O modules:

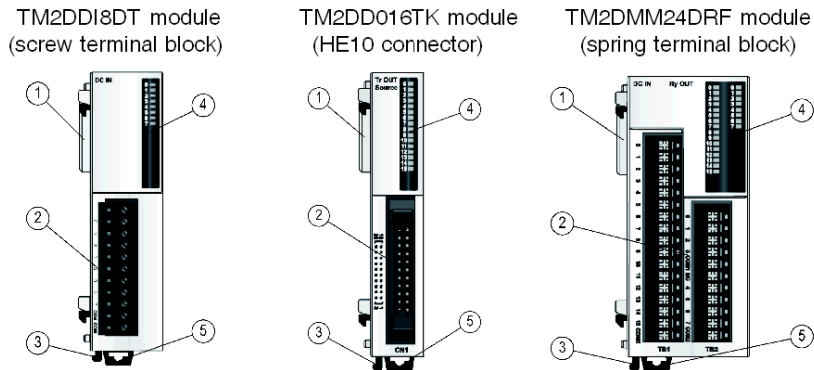

Elements

The following table describes the different elements of the 3 digital I/O modules shown above:

Label	TM2DDI8DT	TM2DDO16TK	TM2DMM24DRF
1	Expansion connector for electrical connection (one on each side, right side not shown). It is designed to provide continuity of the electrical link between the modules connected.		
2	Removable screw terminal block (supplied with the module)	HE10 Connector	Non removable spring terminal block
3	Locking device for attachment to the previous module		
4	Led for displaying the channels and module diagnostics		
5	Clip-on lock		

Accessories

Introduction

This section describes the TM2 Digital I/O modules accessories.

Cables

The following table lists the cables features:

Cable name	Reference
Digital I/O Cables	
Cable equipped at a one end with an HE10 connector. (AWG 22 / 0.34 mm ² ; length: 3 m / 9.84 ft)	TWDFCW30K
Cable equipped at a one end with an HE10 connector. (AWG 22 / 0.34 mm ² ; length: 5 m / 16.4 ft)	TWDFCW50K
Telefast® Cables for TM2 digital I/O expansion modules	
Cable equipped with a HE10 connector at each end. (AWG 28 / 0.08 mm ² ; length: 0.5 m / 1.64 ft)	ABFT20E050
Cable equipped with a HE10 connector at each end. (AWG 28 / 0.08 mm ² ; length: 1 m / 3.28 ft)	ABFT20E100
Cable equipped with a HE10 connector at each end. (AWG 28 / 0.08 mm ² ; length: 2 m / 6.56 ft)	ABFT20E200

Terminal Block End Clamp Type AB1AB8P35

Terminal Block End Clamps (reference AB1AB8P35) help reduce side-to-side movement of your controller and modules on the mounting rail. A controller and its associated modules are mounted on the mounting rail between two end clamps in order to improve the shock and vibration characteristics of the assembly.

The following picture shows an end clamps type AB1AB8P35:

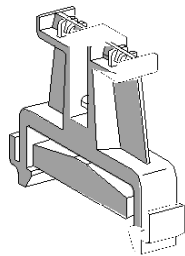

The DIN Rail

You can mount the controller and its expansions on a mounting rail. A mounting rail can be attached to a smooth mounting surface or suspended from a Electronic Industries Alliance rack or in a Type 4 cabinet.

The following picture shows the different sizes of the DIN rail:

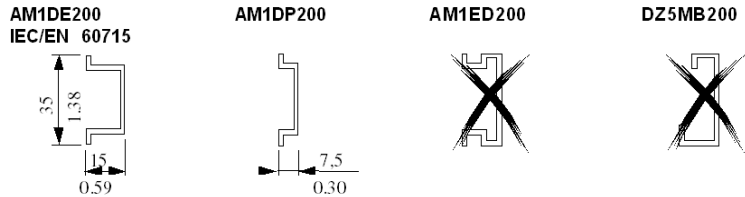

You can order the suitable DIN rail from Schneider Electric:

Rail depth	Catalogue part number
15 mm (0.59 in.)	AM1DE200
7,5 mm (0.30 in.)	AM1DP200

NOTE: Do not use AM1ED200 and DZ5MB200

TWDXMT5 Mounting Strip

The following illustration shows a TWDXMT5 Panel Mount Kit which can be used instead of mounting rail to mount your controller and I/O modules directly to a panel:

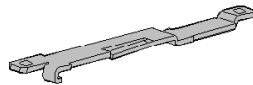

1.2 General Rules for Implementing

Introduction

This section presents the information necessary to install and configure the modules, including mounting, wiring, and grounding requirements.

What's in this Section?

This section contains the following topics:

Topic	Page
Mounting Positions and Minimum Clearances	21
Assembling a Module to a Controller	22
Disassembling a Module from a Controller	24
How to Install and Remove the Controller with its Expansions from Mounting Rail	25
How to Directly Mount a Module on a Panel Surface	27
Wiring Requirements	28

Mounting Positions and Minimum Clearances

Introduction

For mounting positions and minimum clearances, modules are mounted according to the rules defined for the hardware system that you associate with. Refer to the appropriate *Installation* chapter in the system *Hardware* documentation.

WARNING

UNINTENDED EQUIPMENT OPERATION

- Place devices dissipating the most heat at the top of the cabinet and ensure adequate ventilation.
- Avoid placing this equipment next to or above devices that might cause overheating.
- Install the equipment in a location providing the minimum clearances from all adjacent structures and equipment as directed in this document.
- Install all equipment according to the drawings specified in the related documentation.

Failure to follow these instructions can result in death, serious injury, or equipment damage.

Assembling a Module to a Controller

Introduction

This section describes how to assemble a module to a controller.

After attaching new I/O modules to the controller, it is important to update and re-download your application program before placing the system back in service. If you do not revise your application program to reflect the addition of new modules, I/O located on the expansion bus may no longer operate normally.

DANGER

HAZARD OF ELECTRIC SHOCK, EXPLOSION OR ARC FLASH

- Disconnect all power from all equipment including connected devices prior to removing any covers or doors, or installing or removing any accessories, hardware, cables, or wires except under the specific conditions specified in the appropriate hardware guide for this equipment.
- Always use a properly rated voltage sensing device to confirm the power is off where and when indicated.
- Replace and secure all covers, accessories, hardware, cables, and wires and confirm that a proper ground connection exists before applying power to the unit.
- Use only the specified voltage when operating this equipment and any associated products.

Failure to follow these instructions will result in death or serious injury.

WARNING

UNINTENDED EQUIPMENT OPERATION

- Only use software approved by Schneider Electric for use with this equipment.
- Update your application program every time you change the physical hardware configuration.

Failure to follow these instructions can result in death, serious injury, or equipment damage.

Assembling a Module to a Controller

The following procedure shows how to assemble a controller and a module together.

Step	Action
1	Remove all power and dismount any existing controller/IO assembly from its DIN/panel mounting.
2	Remove the expansion connector sticker from the controller or the outermost installed module.
3	Verify that the locking device (<i>see Modicon TM2, Analog I/O Modules, Hardware Guide</i>) on the new module is in the upper position.
4	Align the internal bus connector on the left side of the module with the internal bus connector on the right side of the controller or module.
5	Press the new module towards the controller or module until it "clicks" into place.
6	Push down the locking device (<i>see Modicon TM2, Analog I/O Modules, Hardware Guide</i>) on the top of the new module to lock it to the controller or previously installed module.

Disassembling a Module from a Controller

Introduction

This section describes how to disassemble a module from a controller.

⚠ DANGER

HAZARD OF ELECTRIC SHOCK, EXPLOSION OR ARC FLASH

- Disconnect all power from all equipment including connected devices prior to removing any covers or doors, or installing or removing any accessories, hardware, cables, or wires except under the specific conditions specified in the appropriate hardware guide for this equipment.
- Always use a properly rated voltage sensing device to confirm the power is off where and when indicated.
- Replace and secure all covers, accessories, hardware, cables, and wires and confirm that a proper ground connection exists before applying power to the unit.
- Use only the specified voltage when operating this equipment and any associated products.

Failure to follow these instructions will result in death or serious injury.

Disassembling a Module from a Controller

The following procedure describes how to disassemble a module from a controller.

Step	Action
1	Remove all power from the control system.
2	Dismount the assembled controller and modules from the mounting rail or panel (see page 27).
3	Push up the locking device from the bottom of the module to disengage it from the controller.
4	Pull apart the controller and module.

How to Install and Remove the Controller with its Expansions from Mounting Rail

Overview

This section describes how to install and remove the controller with its expansions from a mounting rail.

NOTE: When mounting a controller and its modules on a mounting rail, use two terminal block end clamps of type AB1 AB8P35 or equivalent in order to improve the shock and vibration characteristics of the assembly.

How to Install a Controller with its Expansions on a Mounting Rail

The following procedure describes how to install a controller with its expansions on a mounting rail:

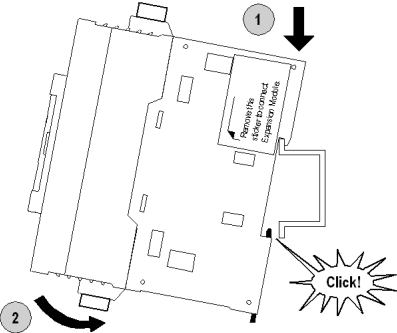
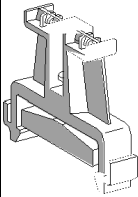
Step	Action
1	Fasten the mounting rail to a panel using screws.
2	Pull down the clip-on-lock at the bottom of the controller and module assembly. 
3	Put the top groove of the controller and modules on the mounting rail and press the assembly toward the mounting rail.
4	Push the clip-on lock of the module into the mounting rail.
5	Place two terminal block end clamps on both sides of the controller and module assembly to help minimize side-to-side movement. 

How to Remove a Controller with its Expansions from a Mounting Rail

The following procedure describes how to remove a controller with its expansions from a mounting rail:

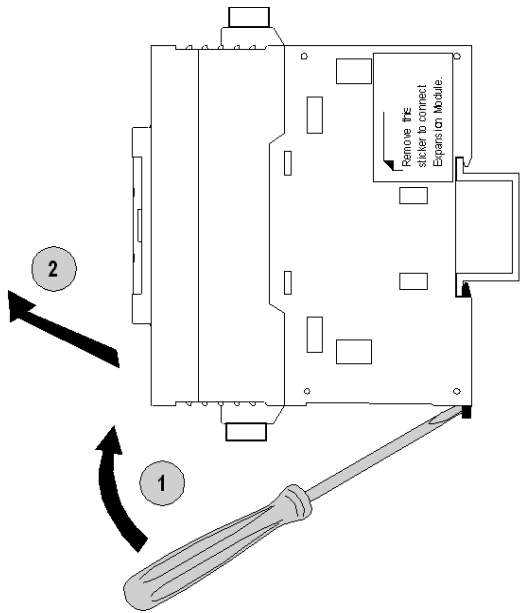
Step	Action
1	<p>Insert a flat screwdriver into the slot in the clip-on-lock.</p>  <p>Remove the sticker to connect Expansion Module.</p>
2	Pull down the clip-on lock.
3	Tilt and lift the controller and its associated modules off of the mounting rail from the bottom.

How to Directly Mount a Module on a Panel Surface

Overview

This section shows how to install your module using the Panel Mounting Kit. This section also provides mounting hole layout for all modules. Your module may differ from the module appearing in these illustrations but the procedure is still applicable.

Installing the Panel Mount Kit

The following procedure shows how to install a mounting strip.

Step	Action
1	Remove the clip-on-lock from the back side of the module by pushing the clip-on lock upwards.
2	Insert the mounting strip, with the hook entering last, into the slot where the clip-on lock was removed.
3	Slide the mounting strip into the slot until the hook enters into the recess in the module.

The following illustration shows how to attach the TWDXMT5 Panel Mount Kit to a module:

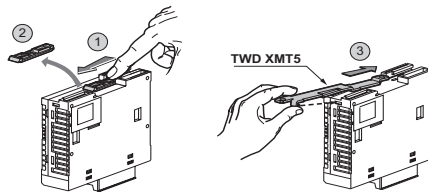

Mounting Hole Layout for Modules

The following diagram shows the mounting hole layout for all modules:

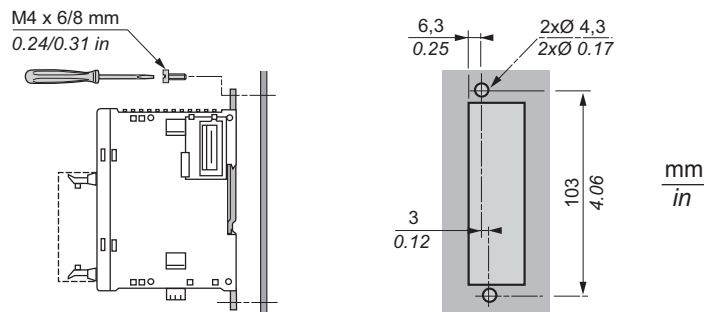

Wiring Requirements

Introduction

There are several rules that must be followed when wiring a TM2 I/O module.

For modules that have more than one terminal block or connector that is identical, any of them can be potentially plugged into any socket.

Despite the indicators on the terminal blocks, connectors and modules, it is possible to incorrectly install the terminal blocks or connectors and create incorrect wiring.

Plugging a connector into the wrong socket could cause unintended behavior of the application.

DANGER

UNINTENDED EQUIPMENT OPERATION OR ELECTRIC SHOCK

Be sure to connect the terminal blocks to their designated location.

Failure to follow these instructions will result in death or serious injury.

NOTE: Clearly and uniquely label each terminal block and connector with an appropriate system of identification.

Wiring Guidelines

DANGER

HAZARD OF ELECTRIC SHOCK, EXPLOSION OR ARC FLASH

- Disconnect all power from all equipment including connected devices prior to removing any covers or doors, or installing or removing any accessories, hardware, cables, or wires except under the specific conditions specified in the appropriate hardware guide for this equipment.
- Always use a properly rated voltage sensing device to confirm the power is off where and when indicated.
- Replace and secure all covers, accessories, hardware, cables, and wires and confirm that a proper ground connection exists before applying power to the unit.
- Use only the specified voltage when operating this equipment and any associated products.

Failure to follow these instructions will result in death or serious injury.

The following rules must be applied when wiring the digital I/O modules:

- I/O and communication wiring must be kept separate from the power wiring. Route these 2 types of wiring in separate cable ducting.
- Verify that the operating conditions and environment are within the specification values.
- Use proper wire sizes to meet voltage and current requirements.
- Use copper conductors only.
- Use twisted-pair, shielded cables for analog, expert and/or fast I/O.
- Use twisted-pair, shielded cables for networks and field bus (CANopen, serial, Ethernet).

⚠ WARNING

UNINTENDED EQUIPMENT OPERATION

- Use shielded cables for all input, output and communication types specified above.
- Properly ground the cable shields as indicated in the related documentation.
- Route communications and I/O cables separately from power cables.

Failure to follow these instructions can result in death, serious injury, or equipment damage.

For more details, refer to Grounding (see page 32).

The following table shows the cable types and wire sizes for removable screw terminal block:

mm ²	0,14...1,5	0,25...0,5	0,25...1,5	0,14...0,5	0,14...0,75	0,25...0,34	0,5
AWG	26...16	24...20	24...16	26...20	26...18	24...22	20

<p>Ø 2,5 mm (0.10 in)</p>		Nm	0,23
		lb-in.	2,0

Use copper conductors only

Applying torque above the limit may damage the terminal screw or threads.

CAUTION

INOPERABLE EQUIPMENT

Do not tighten screw terminals beyond the specified maximum torque (Nm / lb-in.).

Failure to follow these instructions can result in equipment damage.

The table below shows the characteristics of the non-removable spring terminal blocks:

Characteristic		Available
Type of terminal blocks		Spring terminal blocks
Number of wires or cable ends accommodated		1
Wire gauges accommodated	minimum	AWG 20 (0.5 mm ²)
	maximum	AWG 18 (1 mm ²)
Wiring constraints		To insert and remove wires from the connectors, use a 2,5 x 0,4 mm (0.10 x 0.02 in) screwdriver to open the round receptacle by pushing on the corresponding plate. Push the flexible plate down on the outside (the side closest to the corresponding receptacle). A screwing (rotating) or bending motion is not required.

Protecting Outputs from Inductive Load Damage

Depending on the load, a protection circuit may be needed for the outputs on the controllers and certain modules. Inductive loads using DC voltages may create voltage reflections resulting in overshoot that will damage or shorten the life of output devices.

 CAUTION
OUTPUT CIRCUIT DAMAGE DUE TO INDUCTIVE LOADS Use an appropriate external protective circuit or device to reduce the risk of inductive direct current load damage. Failure to follow these instructions can result in injury or equipment damage.

Relay outputs can support up to 240 Vac. Inductive damage to these types of outputs can result in welded contacts and loss of control. Each inductive load must be equipped with a protection device such as a peak limiter, RC circuit or flyback diode. Capacitive loads are not supported by these relays.

⚠ WARNING

RELAY OUTPUTS WELDED CLOSED

- Always protect relay outputs from inductive alternating current load damage using an appropriate external protective circuit or device.
- Do not connect relay outputs to capacitive loads.

Failure to follow these instructions can result in death, serious injury, or equipment damage.

Protective circuit A: this protection circuit can be used for both AC and DC load power circuits.

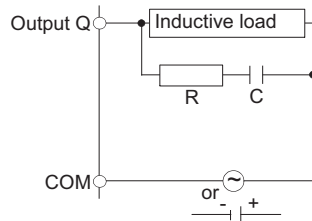

- C represents a value from 0.1 to 1 μF .
- R represents a resistor of approximately the same resistance value as the load.

Protective circuit B: this protection circuit can be used for DC load power circuits.

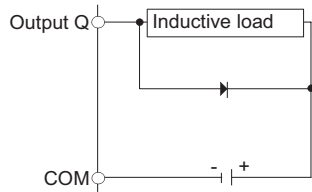

Use a diode with the following ratings:

- Reverse withstand voltage: power voltage of the load circuit x 10.
- Forward current: more than the load current.

Protective circuit C: this protection circuit can be used for both AC and DC load power circuits.

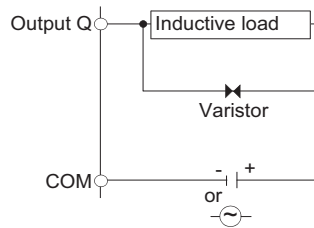

- In applications where the inductive load is switched on and off frequently and/or rapidly, ensure that varistor's continuous energy rating (J) exceeds the peak load energy by 20% or more.

NOTE: The above schematics show sinking DC outputs, but would apply equally to source outputs.

Grounding

Electromagnetic radiation may interfere with control communications and/or input/output signals to the control system.

⚠ WARNING

UNINTENDED EQUIPMENT OPERATION

- Use shielded cables wherever specified for inputs, outputs and communication connections.
- Properly ground the cable shields as indicated in the related documentation.
- Route communication and I/O cables separately from power cables.

Failure to follow these instructions can result in death, serious injury, or equipment damage.

Grounding Bar TM2XMTGB

The figure below shows how to connect the grounding bar TM2XMTGB:

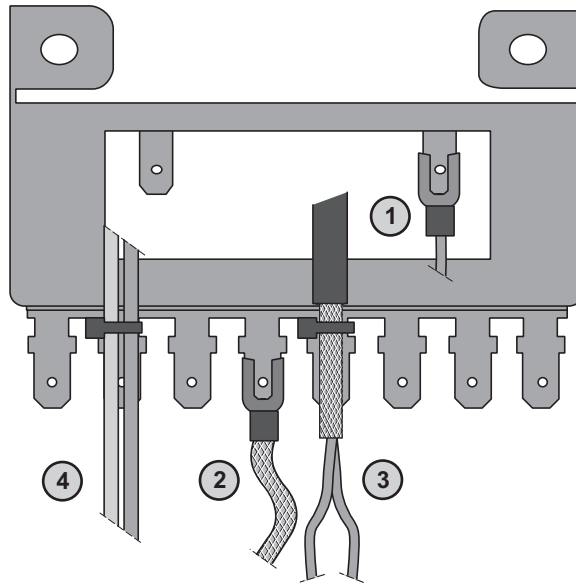

- 1 Controller functional grounding
- 2 Modules functional grounding
- 3 Analog fast I/O cable shielding
- 4 Cable attachment

NOTE: Schneider Electric recommends the use of the TM2XMTGB the Grounding Bar for use with all TM2 I/O modules.

⚠ WARNING

ACCIDENTAL DISCONNECTION FROM PROTECTIVE GROUND (PE)

- Do not use the TM2 XMTGB Grounding Bar to provide a protective ground (PE).
- Use the TM2 XMTGB Grounding Bar only to provide a functional ground (FE).

Failure to follow these instructions can result in death, serious injury, or equipment damage.

Environmental Characteristics of TM2 I/O Modules

2

Environmental Characteristics of TM2 I/O Modules

TM2 I/O Modules Environmental Characteristics

All the TM2 digital I/O modules are electrically isolated with the use of a photocoupler between the internal electronic circuit and the input/output channels.

WARNING

UNINTENDED EQUIPMENT OPERATION

Do not exceed any of the rated values specified in the following tables.

Failure to follow these instructions can result in death, serious injury, or equipment damage.

TM2 I/O Modules Climatic and Mechanical Characteristics	
Ambient operating temperature	0... 55 °C (32...131 °F)
Storage temperature (°C)	- 25...70 °C (-13...158 °F)
Relative humidity	10...95 % (non-condensing)
Degree of pollution	2 (IEC 60664)
Degree of protection	IP 20
Corrosion immunity	Free from corrosive gases
Altitude	Operation: 0...2,000 m (0...6,560 ft) Transport: 0...3,000 m (0...9,840 ft)
Vibration resistance When mounted on a DIN rail:	3.5 mm fixed amplitude from 5...8.5 Hz 9.8 m/s ² or 32.152 ft/s ² (1 g) fixed acceleration from 8.5...150 Hz

TM2 I/O Modules Climatic and Mechanical Characteristics	
Vibration resistance When mounted on a panel surface:	10 mm fixed amplitude from 5...8.7 Hz 29.4 m/s ² or 96.457 ft/s ² (3 g) fixed acceleration from 8.7...150 Hz
Mechanical shock resistance	147 m/s ² or 482.285 ft/s ² (15 g) for 11 ms duration

TM2 I/O Modules EMC Characteristics	
Electrostatic discharge IEC/EN 61000-4-2	8 kV (air discharge) 6 kV (contact discharge)
Radiated electromagnetic field IEC/EN 61000-4-3	10 V/m (80 MHz... 2 GHz) 1 V/m (2... 2.7 GHz)
Magnetic field IEC/EN 61000-4-8	30 A/m
Fast Transient Burst IEC/EN 61000-4-4	2 kV
Induced electromagnetic field IEC/EN 61000-4-6	10 Veff (150...80 MHz)
Surge immunity IEC/EN 61000-4-5 24 Vdc circuit:	1 kV in Common mode 0.5 kV in differential mode
Surge immunity IEC/EN 61000-4-5 230 Vac circuit:	2 kV in Common mode 1 kV in differential mode
Radiated and conducted emissions	Class B: according to IEC61000-6-4 For GL: according to EMC2 environment (for modules compliant to GL)

TM2DAI8DT Digital Input Module

3

Overview

This chapter describes the TM2DAI8DT module, its characteristics and its connection to the different sensors.

What's in this Chapter?

This chapter contains the following topics:

Topic	Page
Presentation of the TM2DAI8DT Module	38
Characteristics of the TM2DAI8DT Module	39
Connecting the TM2DAI8DT Module	41

Presentation of the TM2DAI8DT Module

TM2DAI8DT Main Characteristics

Number of input channels	8
Input type	Type 1
Signal type	AC type
Rated input voltage	120 Vac
Connection type	Removable screw terminal block

Characteristics of the TM2DAI8DT Module

Introduction

This section provides a description of the electrical and the input characteristics of the TM2DAI8DT module.

See also Environmental Characteristics (see page 35).

⚠ WARNING

UNINTENDED EQUIPMENT OPERATION

Do not exceed any of the rated values specified in the following tables.

Failure to follow these instructions can result in death, serious injury, or equipment damage.

Dimensions

The following diagrams show the dimensions for the TM2DAI8DT module.

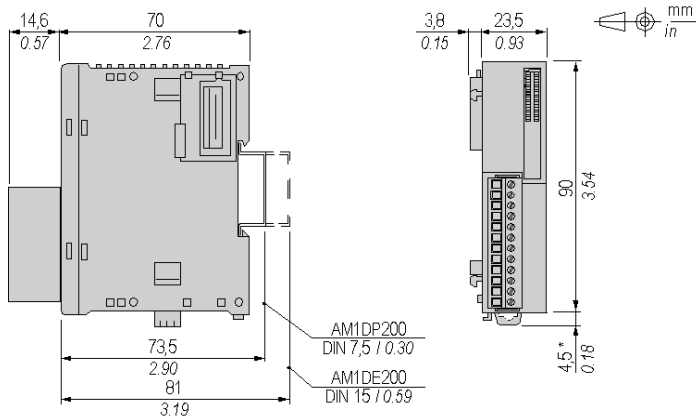

NOTE: * 8.5 mm (0.33 in) when the clamp is pulled out.

TM2DAI8DT Electrical Characteristics

Isolation	Between input and internal bus: 1500 Vac Between input terminals: not isolated
Connector insertion/removal durability	Over 100 times
Current draw on 5 Vdc internal bus	55 mA (all outputs on) 25 mA (all outputs off)
Current draw on 24 Vdc internal bus	0 mA (all outputs on) 0 mA (all outputs off)

TM2DAI8DT Input Characteristics

Number of input channels	8
Common lines	2
Input signals type	AC type
Rated input voltage	120 Vac
Input voltage range	85...132 Vac
Rated input current at 100 Vac	7.5 mA
Input impedance	11 k Ω
OFF state	$U < 20 \text{ Vac}$
ON state	$U > 79 \text{ Vac}$ $I > 2 \text{ mA}$
Turn on time	25 ms
Turn off time	30 ms
Input type	Type 1 (IEC 61131-2)

Connecting the TM2DAI8DT Module

Introduction

TM2DAI8DT is a 8-channel, 120 Vac input module.

This module is fitted with a removable connection screw terminal block for the connection of inputs and power supply.

Wiring Rules

See Wiring Requirements (*see page 28*).

TM2DDAI8DT Wiring Diagram

The following diagram shows the connection of the inputs module (on the right) to the sensors (on the left).

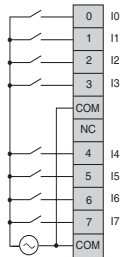

The two COM terminals are **not** connected together internally.

⚠ WARNING

UNINTENDED EQUIPMENT OPERATION

Do not connect wires to unused terminals or terminals marked “Not Connected (N.C.)”.

Failure to follow these instructions can result in death, serious injury, or equipment damage.

TM2DDI8DT Digital Input Module

4

Overview

This chapter describes the TM2DDI8DT module, its characteristics and its connection to the different sensors.

What's in this Chapter?

This chapter contains the following topics:

Topic	Page
Presentation of the TM2DDI8DT Module	44
Characteristics of the TM2DDI8DT Module	45
Connecting the TM2DDI8DT Module	48

Presentation of the TM2DDI8DT Module

TM2DDI8DT Main Characteristics

Number of input channels	8
Input type	Type 1
Signal type	Sink/Source
Rated input voltage	24 Vdc
Connection type	Removable screw terminal block

Characteristics of the TM2DDI8DT Module

Introduction

This section provides a description of the electrical and the input characteristics of the TM2DDI8DT module.

See also Environmental Characteristics (see page 35).

⚠ WARNING

UNINTENDED EQUIPMENT OPERATION

Do not exceed any of the rated values specified in the following tables.

Failure to follow these instructions can result in death, serious injury, or equipment damage.

Dimensions

The following diagrams show the dimensions for the TM2DDI8DT module.

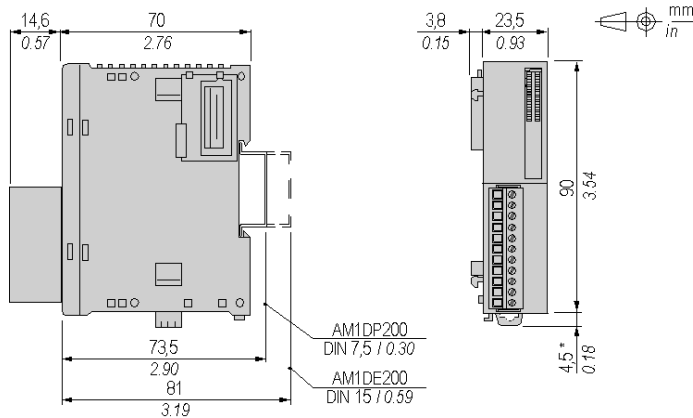

NOTE: * 8.5 mm (0.33 in) when the clamp is pulled out.

TM2DDI8DT Electrical Characteristics

Isolation	Between input and internal bus: 500 Vac Between input terminals: not isolated
Connector insertion/removal durability	Over 100 times
Current draw on 5 Vdc internal bus	25 mA (all inputs on) 5 mA (all inputs off)
Current draw on 24 Vdc internal bus	0 mA (all inputs on) 0 mA (all inputs off)

TM2DDI8DT Input Characteristics

Number of input channels	8
Common lines	1
Input signals type	sink or source
Rated input voltage	24 Vdc
Input voltage range	20.4...28.8 Vdc
Rated input current at 24 Vdc	7 mA
Input impedance	3.4 k Ω
OFF state	U < 5 Vdc
ON state	U > 15 Vdc I > 2 mA
Turn on time	4 ms
Turn off time	4 ms
Input type	Type 1 (IEC 61131-2)

Usage Limits

When using TM2DDI8DT:

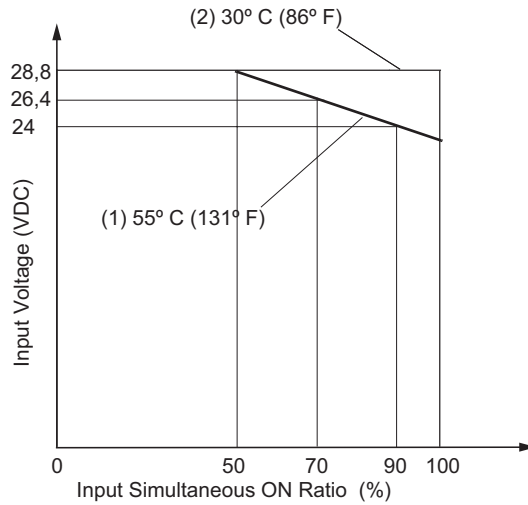

- 1 90% of the inputs can be turned on simultaneously at 55 °C, 24 Vdc input voltage.
- 2 All inputs can be turned on simultaneously at 30 °C, 28.8 Vdc input voltage.

Connecting the TM2DDI8DT Module

Introduction

TM2DDI8DT is a 8-channel, 24 Vdc input module.

This module is fitted with a removable connection screw terminal block for the connection of inputs and power supply.

Wiring Rules

See Wiring Requirements (see page 28).

TM2DDI8DT Wiring Diagram

The following diagram shows the connection of the inputs module (on the right) to the sensors (on the left).

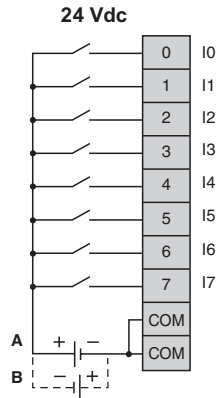

- The COM terminals are connected together internally.
- Both sink and source input wiring are supported.
- A is the sink wiring (positive logic).
- B is the source wiring (negative logic).

⚠ WARNING

UNINTENDED EQUIPMENT OPERATION

Do not connect wires to unused terminals or terminals marked "Not Connected (N.C.)".

Failure to follow these instructions can result in death, serious injury, or equipment damage.

TM2DDI16DT Digital Input Module

5

Overview

This chapter describes the TM2DDI16DT module, its characteristics and its connection to the different sensors.

What's in this Chapter?

This chapter contains the following topics:

Topic	Page
Presentation of the TM2DDI16DT Module	50
Characteristics of the TM2DDI16DT Module	51
Connecting the TM2DDI16DT Module	53

Presentation of the TM2DDI16DT Module

TM2DDI16DT Main Characteristics

Number of input channels	16
Input type	Type 1
Signal type	Sink/Source
Rated input voltage	24 Vdc
Connection type	Removable screw terminal block

Characteristics of the TM2DDI16DT Module

Introduction

This section provides a description of the electrical and the input characteristics of the TM2DDI16DT module.

See also Environmental Characteristics (see page 35).

<h2 style="margin: 0;">⚠ WARNING</h2>
<p>UNINTENDED EQUIPMENT OPERATION</p> <p>Do not exceed any of the rated values specified in the following tables.</p> <p>Failure to follow these instructions can result in death, serious injury, or equipment damage.</p>

Dimensions

The following diagrams show the dimensions for the TM2DDI16DT module.

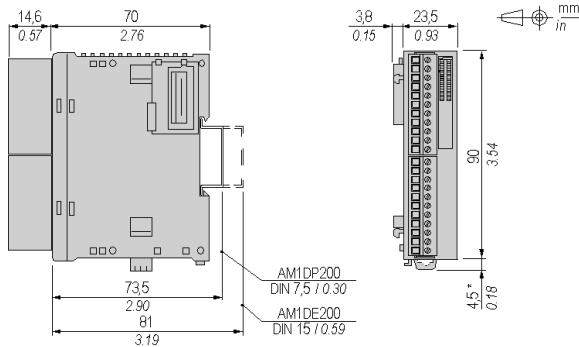

NOTE: * 8.5 mm (0.33 in) when the clamp is pulled out.

TM2DDI16DT Electrical Characteristics

Isolation	Between input and internal bus: 500 Vac Between input terminals: not isolated
Connector insertion/removal durability	Over 100 times
Current draw on 5 Vdc internal bus	40 mA (all inputs on) 5 mA (all inputs off)
Current draw on 24 Vdc internal bus	0 mA (all inputs on) 0 mA (all inputs off)

TM2DDI16DT Input Characteristics

Number of input channels	16
Common lines	1
Input signals type	sink or source
Rated input voltage	24 Vdc
Input voltage range	20.4...28.8 Vdc
Rated input current at 24 Vdc	7 mA
Input impedance	3.4 kΩ
OFF state	U < 5 Vdc
ON state	U > 15 Vdc I > 2 mA
Turn on time	4 ms
Turn off time	4 ms
Input type	Type 1 (IEC 61131-2)

Usage Limits

When using TM2DDI16DT:

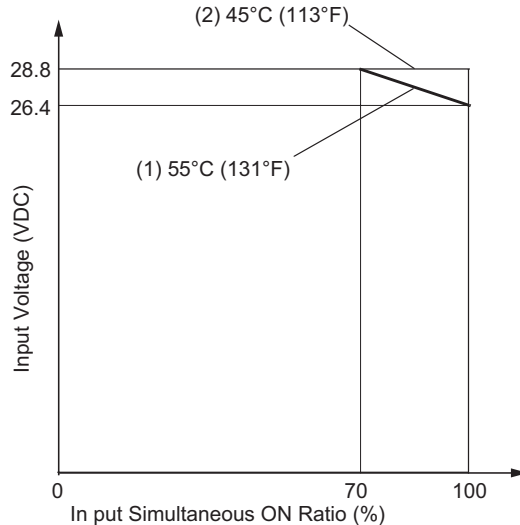

- 1 At 55°C (131 °F) in the normal mounting direction, limit the inputs which turn on simultaneously along line.
- 2 At 45°C (113 °F), all inputs can be turned on simultaneously at 28.8 Vdc as indicated with line.

Connecting the TM2DDI16DT Module

Introduction

TM2DDI16DT is a 16-channel, 24 Vdc input module.

This module is fitted with a removable connection screw terminal block for the connection of inputs and power supply.

Wiring Rules

See Wiring Requirements (*see page 28*).

TM2DDI16DT Wiring Diagram

The following diagram shows the connection of the inputs module (on the right) to the sensors (on the left).

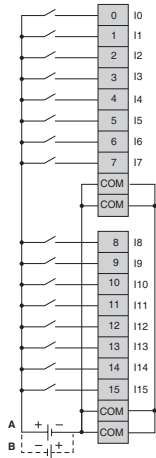

- The COM terminals are connected together internally.
- Both sink and source input wiring are supported.
- A is the sink wiring (positive logic).
- B is the source wiring (negative logic).

⚠ WARNING

UNINTENDED EQUIPMENT OPERATION

Do not connect wires to unused terminals or terminals marked "Not Connected (N.C.)".

Failure to follow these instructions can result in death, serious injury, or equipment damage.

TM2DDI16DK Digital Input Module

6

Overview

This chapter describes the TM2DDI16DK module, its characteristics and its connection to the different sensors.

What's in this Chapter?

This chapter contains the following topics:

Topic	Page
Presentation of the TM2DDI16DK Module	56
Characteristics of the TM2DDI16DK Module	57
Connecting the TM2DDI16DK Module	59

Presentation of the TM2DDI16DK Module

TM2DDI16DK Main Characteristics

Number of input channels	16
Input type	Type 1
Signal type	Sink/Source
Rated input voltage	24 Vdc
Connection type	HE10 connector

Characteristics of the TM2DDI16DK Module

Introduction

This section provides a description of the electrical and the input characteristics of the TM2DDI16DK module.

See also Environmental Characteristics (see page 35).

 WARNING
<p>UNINTENDED EQUIPMENT OPERATION</p> <p>Do not exceed any of the rated values specified in the following tables.</p> <p>Failure to follow these instructions can result in death, serious injury, or equipment damage.</p>

Dimensions

The following diagrams show the dimensions for the TM2DDI16DK module.

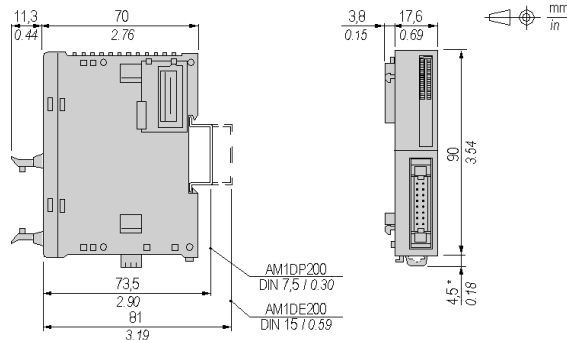

NOTE: * 8.5 mm (0.33 in) when the clamp is pulled out.

TM2DDI16DK Electrical Characteristics

Isolation	Between input and internal bus: 500 Vac Between input terminals: not isolated
Connector insertion/removal durability	Over 100 times
Current draw on 5 Vdc internal bus	35 mA (all inputs on) 5 mA (all inputs off)
Current draw on 24 Vdc internal bus	0 mA (all inputs on) 0 mA (all inputs off)

TM2DDI16DK Input Characteristics

Number of input channels	16
Common lines	1
Input signals type	sink or source
Rated input voltage	24 Vdc
Input voltage range	20.4...28.8 Vdc
Rated input current at 24 Vdc	5 mA
Input impedance	4.4 kΩ
OFF state	$U < 5 \text{ Vdc}$
ON state	$U > 15 \text{ Vdc}$ $I > 2 \text{ mA}$
Turn on time	4 ms
Turn off time	4 ms
Input type	Type 1 (IEC 61131-2)

Usage Limits

When using TM2DDI16DK:

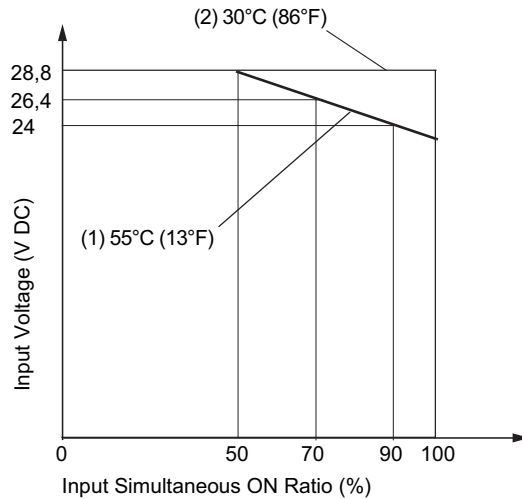

- 1 At 55 °C (131 °F), limit the inputs which turn on simultaneously on each connector along line.
- 2 At 30 °C (86 °F), all inputs can be turned on simultaneously at 28.8 Vdc as indicated with line.

Connecting the TM2DDI16DK Module

Introduction

TM2DDI16DK is a 16-channel, 24 Vdc input module.

This module is fitted with HE10 connector for the connection of inputs and power supply.

Wiring Rules

See Wiring Requirements (*see page 28*).

TM2DDI16DK Wiring Diagram

The following diagram shows the connection of the inputs module to the sensors.

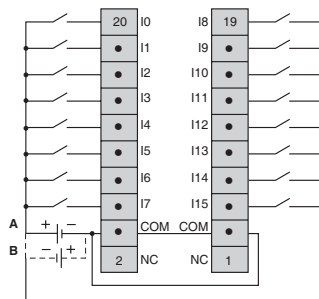

- The COM terminals are connected together internally.
- Both sink and source input wiring are supported.
- A is the sink wiring (positive logic).
- B is the source wiring (negative logic).

⚠ WARNING

UNINTENDED EQUIPMENT OPERATION

Do not connect wires to unused terminals or terminals marked "Not Connected (N.C.)".

Failure to follow these instructions can result in death, serious injury, or equipment damage.

TM2DDI32DK Digital Input Module

7

Overview

This chapter describes the TM2DDI32DK module, its characteristics and its connection to the different sensors.

What's in this Chapter?

This chapter contains the following topics:

Topic	Page
Presentation of the TM2DDI32DK Module	62
Characteristics of the TM2DDI32DK Module	63
Connecting the TM2DDI32DK Module	65

Presentation of the TM2DDI32DK Module

TM2DDI32DK Main Characteristics

Number of input channels	32
Input type	Type 1
Signal type	Sink/Source
Rated input voltage	24 Vdc
Connection type	HE10 connector

Characteristics of the TM2DDI32DK Module

Introduction

This section provides a description of the electrical and the input characteristics of the TM2DDI32DK module.

See also Environmental Characteristics (see page 35).

 WARNING
<p>UNINTENDED EQUIPMENT OPERATION</p> <p>Do not exceed any of the rated values specified in the following tables.</p> <p>Failure to follow these instructions can result in death, serious injury, or equipment damage.</p>

Dimensions

The following diagrams show the dimensions for the TM2DDI32DK module.

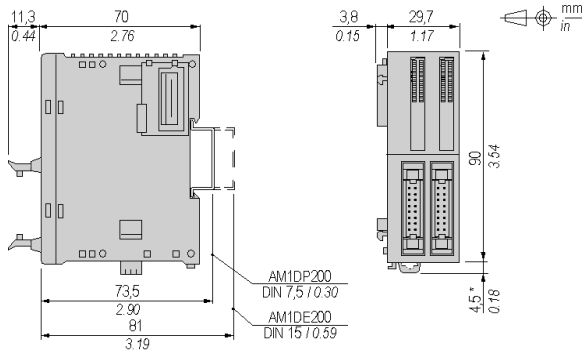

NOTE: * 8.5 mm (0.33 in) when the clamp is pulled out.

TM2DDI32DK Electrical Characteristics

Isolation	Between input and internal bus: 500 Vac Between input terminals: not isolated
Connector insertion/removal durability	Over 100 times
Current draw on 5 Vdc internal bus	65 mA (all inputs on) 10 mA (all inputs off)
Current draw on 24 Vdc internal bus	0 mA (all inputs on) 0 mA (all inputs off)

TM2DDI32DK Input Characteristics

Number of input channels	32
Common lines	1 common line for 16 channels
Input signals type	sink or source
Rated input voltage	24 Vdc
Input voltage range	20.4...28.8 Vdc
Rated input current at 24 Vdc	5 mA
Input impedance	4.4 kΩ
OFF state	$U < 5 \text{ Vdc}$
ON state	$U > 15 \text{ Vdc}$ $I > 2 \text{ mA}$
Turn on time	4 ms
Turn off time	4 ms
Input type	Type 1 (IEC 61131-2)

Usage Limits

When using TM2DDI32DK:

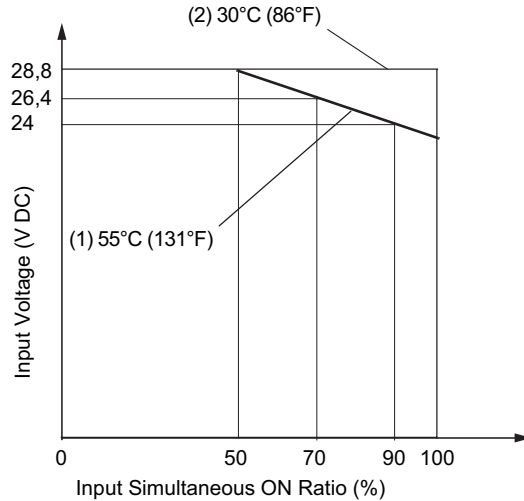

- 1 At 55°C (131°F), limit the inputs which turn on simultaneously on each connector along line.
- 2 At 30°C (86°F), all inputs can be turned on simultaneously at 28.8 Vdc as indicated with line.

Connecting the TM2DDI32DK Module

Introduction

TM2DDI32DK is a 32-channel, 24 Vdc input module.

This module is fitted with HE10 connector for the connection of inputs and power supply.

Wiring Rules

See Wiring Requirements (*see page 28*).

TM2DDI32DK Wiring Diagram

The following diagram shows the connection of the inputs module to the sensors.

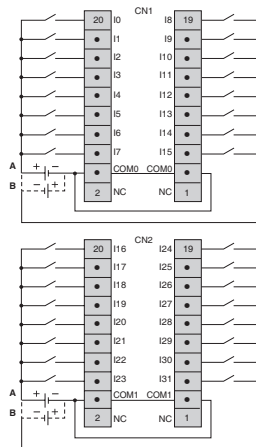

- The COM0 terminals are connected together internally.
- The COM1 terminals are connected together internally.
- The COM0 and COM1 terminals are **not** connected together internally.
- Both sink and source input wiring are supported
- A is the sink wiring (positive logic).
- B is the source wiring (negative logic).

⚠ WARNING

UNINTENDED EQUIPMENT OPERATION

Do not connect wires to unused terminals or terminals marked "Not Connected (N.C.)".

Failure to follow these instructions can result in death, serious injury, or equipment damage.

TM2DRA8RT Digital Relay Output Module



8

Overview

This chapter describes the TM2DRA8RT module, its characteristics and its connection to the different sensors.

What's in this Chapter?

This chapter contains the following topics:

Topic	Page
Presentation of the TM2DRA8RT Module	68
Characteristics of the TM2DRA8RT Module	69
Connecting the TM2DRA8RT Module	72

Presentation of the TM2DRA8RT Module

TM2DRA8RT Main Characteristics

Output points and common lines	8 contacts in 2 common lines
Output type	Relay (1 NO contact)
Voltage/current	24 Vdc/2 A max 240 Vac/2 A max
Connection type	Removable screw terminal block

Characteristics of the TM2DRA8RT Module

Introduction

This section provides a description of the power limitation, the electrical and the output characteristics of the TM2DRA8RT module.

See also Environmental Characteristics (see page 35).

⚠ DANGER

FIRE HAZARD

Use only the recommended wire sizes for I/O channels and power supplies.

Failure to follow these instructions will result in death or serious injury.

⚠ WARNING

UNINTENDED EQUIPMENT OPERATION

Do not exceed any of the rated values specified in the following tables.

Failure to follow these instructions can result in death, serious injury, or equipment damage.

Dimensions

The following diagrams show the dimensions for the TM2DRA8RT module.

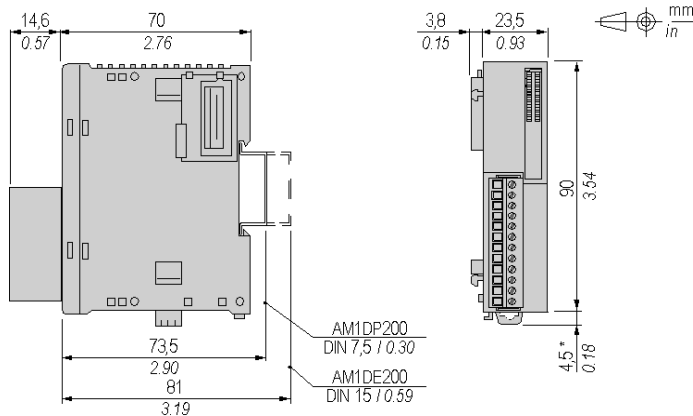

NOTE: * 8.5 mm (0.33 in) when the clamp is pulled out.

TM2DRA8RT Electrical Characteristics

Connector insertion/removal durability	Over 100 times
Current draw on 5 Vdc internal bus	30 mA (all outputs on) 5 mA (all outputs off)
Current draw on 24 Vdc internal bus	40 mA (all outputs on) 0 mA (all outputs off)

TM2DRA8RT Output Characteristics

Output channels	8
Common lines	1 common line for 4 channels
Output current	2 A max per output 7 A max per common line
Rated voltage	24 Vdc 230 / 240 Vac
Max voltage	30 Vdc 264 Vac
In rush current	2 A max
Minimum switching load	0.1 mA 0.1 Vdc
Contact resistance	45 mΩ max
Mechanical life	20 million operations minimum (no load 1,800 operations/h)
Resistive load Inductive load Capacitive load	See Power Limitation below
Isolation	Between output and internal bus: 2300 Vac Between output and 0V terminals: 1500 Vac Between output groups: 1500 Vac
Turn on time	12 ms
Turn off time	10 ms

TM2DRA8RT Power Limitation

The following table shows the power limitation of the TM2DRA8RT module depending on the voltage, the type of load and the number of operations required.

Capacitive loads are not supported by this module.

 WARNING
RELAY OUTPUTS WELDED CLOSED
<ul style="list-style-type: none"> ● Always protect relay outputs from inductive alternating current load damage using an appropriate external protective circuit or device. ● Do not connect relay outputs to capacitive loads.
Failure to follow these instructions can result in death, serious injury, or equipment damage.

Voltage	24 Vdc	120 Vdc	240 Vdc	Number of operations
Power of resistive loads AC-12		240 VA 80 VA	480 VA 160 VA	100,000 300,000
Power of inductive loads AC-15 (cos x=0.3)		60 VA 18 VA	120 VA 36 VA	100,000 300,000
Power of inductive loads AC-14 (cos x=0.7)		120 VA 36 VA	240 VA 72 VA	100,000 300,000
Power of resistive loads DC-12	48 W 16 W			100,000 300,000
Power of inductive loads DC-13 L/R=7ms	24 W 7.2 W			100,000 300,000

Connecting the TM2DRA8RT Module

Introduction

TM2DRA8RT is a 8-channel, relay output module.

This module is fitted with a removable connection screw terminal block for the connection of outputs.

Wiring Rules

See Wiring Requirements (see page 28).

TM2DRA8RT Wiring Diagram

The following diagram shows the connection of the outputs and the relay output wiring (see page 30).

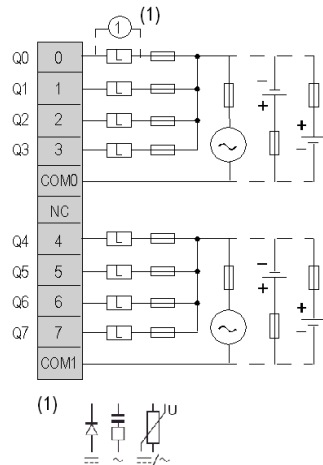

- The COM0 and COM1 terminals are **not** connected together internally.
- Connect a fuse for the load, not to exceed 7 A.
- (1) is the protection for inductive load.

⚠ WARNING

UNINTENDED EQUIPMENT OPERATION

Do not connect wires to unused terminals or terminals marked “Not Connected (N.C.)”.

Failure to follow these instructions can result in death, serious injury, or equipment damage.

TM2DRA16RT Digital Relay Output Module

9

Overview

This chapter describes the TM2DRA16RT module, its characteristics and its connection to the different sensors.

What's in this Chapter?

This chapter contains the following topics:

Topic	Page
Presentation of the TM2DRA16RT Module	74
Characteristics of the TM2DRA16RT Module	75
Connecting the TM2DRA16RT Module	78

Presentation of the TM2DRA16RT Module

TM2DRA16RT Main Characteristics

Output points and common lines	16 contacts in 2 common lines
Output type	Relay (1 NO contact)
Voltage/current	24 Vdc/2 A max 240 Vac/2 A max
Connection type	Removable screw terminal block

Characteristics of the TM2DRA16RT Module

Introduction

This section provides a description of the power limitation, the electrical and the output characteristics of the TM2DRA16RT module.

See also Environmental Characteristics (see page 35).

⚠ DANGER

FIRE HAZARD

Use only the recommended wire sizes for I/O channels and power supplies.

Failure to follow these instructions will result in death or serious injury.

⚠ WARNING

UNINTENDED EQUIPMENT OPERATION

Do not exceed any of the rated values specified in the following tables.

Failure to follow these instructions can result in death, serious injury, or equipment damage.

Dimensions

The following diagrams show the dimensions for the TM2DRA16RT module.

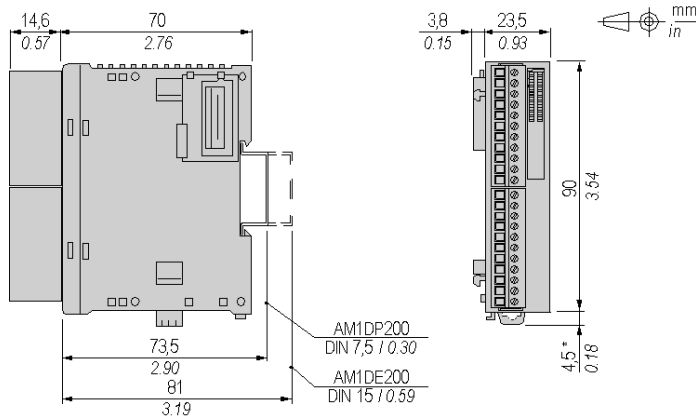

NOTE: * 8.5 mm (0.33 in) when the clamp is pulled out.

TM2DRA16RT Electrical Characteristics

Connector insertion/removal durability	Over 100 times
Current draw on 5 Vdc internal bus	45 mA (all outputs on) 5 mA (all outputs off)
Current draw on 24 Vdc internal bus	75 mA (all outputs on) 0 mA (all outputs off)

TM2DRA16RT Output Characteristics

Output channels	16
Common lines	1 common line for 8 channels
Output current	2 A max per output 8 A max per common line
Rated voltage	24 Vdc 230 / 240 Vac
Max voltage	30 Vdc 264 Vac
Inrush current	2 A max.
Minimum switching load	0.1 mA 0.1 Vdc
Contact resistance	45 mΩ max
Mechanical life	20 million operations minimum (no load 1,800 operations/h)
Resistive load Inductive load Capacitive load	See Power Limitation below
Isolation	Between output and internal bus: 2300 Vac
Isolation between output and 0V terminals	1500 Vac
Isolation between output groups	1500 Vac
Turn on time	12 ms
Turn off time	10 ms

TM2DRA16RT Power Limitation

The following table shows the power limitation of the TM2DRA16RT module depending on the voltage, the type of load and the number of operations required.

Capacitive loads are not supported by this module.

 WARNING
RELAY OUTPUTS WELDED CLOSED
<ul style="list-style-type: none"> ● Always protect relay outputs from inductive alternating current load damage using an appropriate external protective circuit or device. ● Do not connect relay outputs to capacitive loads. <p>Failure to follow these instructions can result in death, serious injury, or equipment damage.</p>

Voltage	24 Vdc	120 Vdc	240 Vdc	Number of operations
Power of resistive loads AC-12		240 VA 80 VA	480 VA 160 VA	100,000 300,000
Power of inductive loads AC-15 (cos x=0.3)		60 VA 18 VA	120 VA 36 VA	100,000 300,000
Power of inductive loads AC-14 (cos x=0.7)		120 VA 36 VA	240 VA 72 VA	100,000 300,000
Power of resistive loads DC-12	48 W 16 W			100,000 300,000
Power of inductive loads DC-13 L/R=7ms	24 W 7.2 W			100,000 300,000

Connecting the TM2DRA16RT Module

Introduction

TM2DRA16RT is a 16-channel, relay output module.

This module is fitted with a removable connection screw terminal block for the connection of outputs.

Wiring Rules

See Wiring Requirements (see page 28).

TM2DRA16RT Wiring Diagram

The following diagram shows the connection of the outputs and the relay output wiring (see page 30).

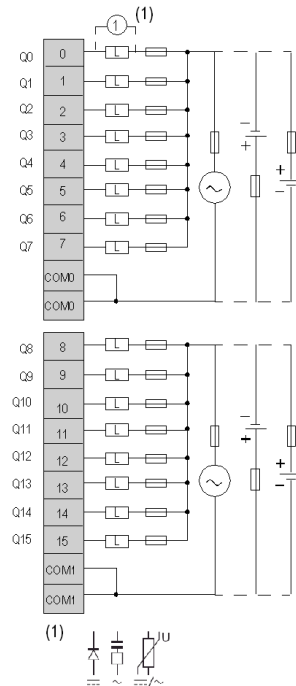

- The COM0 terminals are connected together internally.
- The COM1 terminals are connected together internally.
- The COM0 and COM1 terminals are **not** connected together internally.
- Connect an appropriate fuse for the load.
- (1) is the protection for inductive load.

 WARNING

UNINTENDED EQUIPMENT OPERATION

Do not connect wires to unused terminals or terminals marked “Not Connected (N.C.)”.

Failure to follow these instructions can result in death, serious injury, or equipment damage.

TM2DDO8UT Digital Transistor Output Module

10

Overview

This chapter describes the TM2DDO8UT module, its characteristics and its connection to the different sensors.

What's in this Chapter?

This chapter contains the following topics:

Topic	Page
Presentation of the TM2DDO8UT Module	82
Characteristics of the TM2DDO8UT Module	83
Connecting the TM2DDO8UT Module	85

Presentation of the TM2DDO8UT Module

TM2DDO8UT Main Characteristics

Output points and common lines	8 transistor outputs in 1 common line
Signal type output	Sink
Output voltage	24 Vdc
Connection type	Removable screw terminal block

Characteristics of the TM2DDO8UT Module

Introduction

This section provides a description of the power limitation, the electrical and the output characteristics of the TM2DDO8UT module.
See also Environmental Characteristics (see page 35).

⚠ DANGER

FIRE HAZARD

Use only the recommended wire sizes for I/O channels and power supplies.
Failure to follow these instructions will result in death or serious injury.

⚠ WARNING

UNINTENDED EQUIPMENT OPERATION

Do not exceed any of the rated values specified in the following tables.
Failure to follow these instructions can result in death, serious injury, or equipment damage.

Dimensions

The following diagrams show the dimensions for the TM2DDO8UT module.

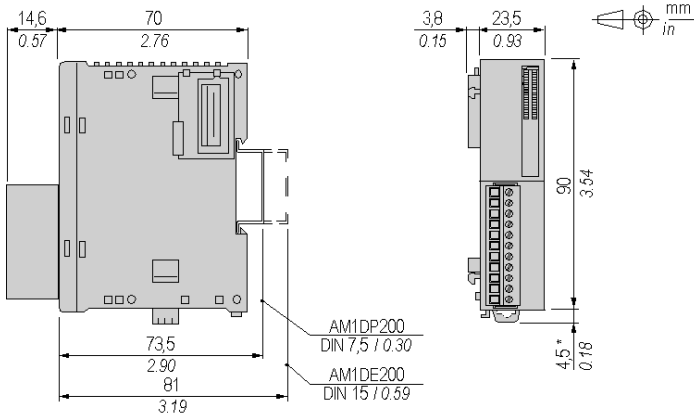

NOTE: * 8.5 mm (0.33 in) when the clamp is pulled out.

TM2DDO8UT Electrical Characteristics

Isolation between output and internal bus	500 Vac
Isolation between output terminals	not isolated
Connector insertion/removal durability	Over 100 times
Current draw on 5 Vdc internal bus	10 mA (all outputs on) 5 mA (all outputs off)
Current draw on 24 Vdc internal bus	20 mA (all outputs on) 0 mA (all outputs off)

TM2DDO8UT Output Characteristics

Output channels	8
Common lines	1 common line for 8 channels
Output current	0.36 A max per output
	2.9 A max per common line
Output voltage	24 Vdc
Output voltage range	20.4...28.8 Vdc
Voltage drop	0.4 Vdc max
Turn on time	450 μ s
Turn off time	450 μ s
Protection against overload and short circuit	External fuse (fast blow, 0.36 A max.)
Protection against reverse polarity	Not protected

Connecting the TM2DDO8UT Module

Introduction

TM2DDO8UT is a 8-channel, transistor output module. This module is fitted with a removable connection screw terminal block for the connection of outputs.

Wiring Rules

See Wiring Requirements (see page 28).

TM2DDO8UT Wiring Diagram

The following diagram shows the connection of the outputs module (on the left) and the transistor output wiring (see page 30) (on the right).

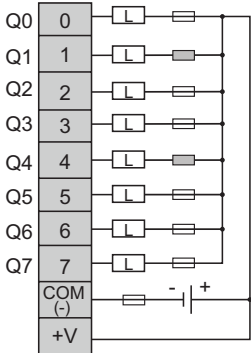

Connect an appropriate fuse for load.

⚠ WARNING
UNINTENDED EQUIPMENT OPERATION
Do not connect wires to unused terminals or terminals marked “Not Connected (N.C.)”.
Failure to follow these instructions can result in death, serious injury, or equipment damage.

TM2DDO8TT Digital Transistor Output Module

11

Overview

This chapter describes the TM2DDO8TT module, its characteristics and its connection to the different sensors.

What's in this Chapter?

This chapter contains the following topics:

Topic	Page
Presentation of the TM2DDO8TT Module	88
Characteristics of the TM2DDO8TT Module	89
Connecting the TM2DDO8TT Module	91

Presentation of the TM2DDO8TT Module

TM2DDO8TT Main Characteristics

Output points and common lines	8 transistor outputs in 1 common line
Signal type output	Source
Output voltage	24 Vdc
Connection type	Removable screw terminal block

Characteristics of the TM2DDO8TT Module

Introduction

This section provides a description of the power limitation, the electrical and the output characteristics of the TM2DDO8TT module.

See also Environmental Characteristics (see page 35).

⚠ DANGER

FIRE HAZARD

Use only the recommended wire sizes for I/O channels and power supplies.

Failure to follow these instructions will result in death or serious injury.

⚠ WARNING

UNINTENDED EQUIPMENT OPERATION

Do not exceed any of the rated values specified in the following tables.

Failure to follow these instructions can result in death, serious injury, or equipment damage.

Dimensions

The following diagrams show the dimensions for the TM2DDO8TT module.

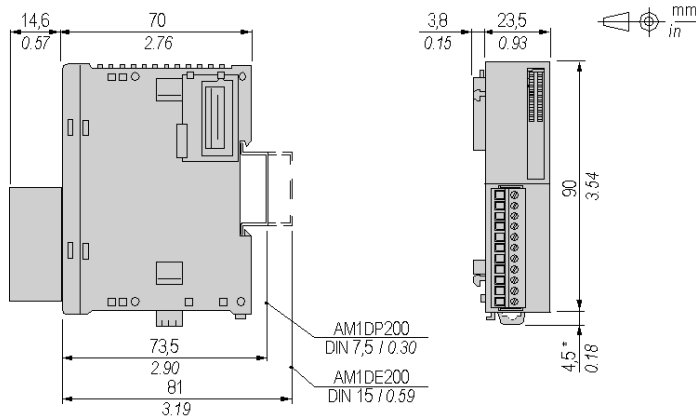

NOTE: * 8.5 mm (0.33 in) when the clamp is pulled out.

TM2DDO8TT Electrical Characteristics

Isolation output and internal bus	500 Vac
Isolation between terminal	not isolated
Connector insertion/removal durability	Over 100 times
Current draw on 5 Vdc internal bus	10 mA (all outputs on) 5 mA (all outputs off)
Current draw on 24 Vdc internal bus	20 mA (all outputs on) 0 mA (all outputs off)

TM2DDO8TT Output Characteristics

Output channels	8
Common lines	1 common line for 8 channels
Output current	0.5 A max per output
	4 A max per common line
Output voltage	24 Vdc
Output voltage range	20.4...28.8 Vdc
Voltage drop	0.4 Vdc max
Turn on time	450 μ s
Turn off time	450 μ s
Output protection against overcurrent and short circuit	Current limitation $I < 1.7$ A All 8 outputs switch off Automatic restart when temperature decreases

Connecting the TM2DDO8TT Module

Introduction

TM2DDO8TT is a 8-channel, transistor output module.

This module is fitted with a removable connection screw terminal block for the connection of outputs.

Wiring Rules

See Wiring Requirements (*see page 28*).

TM2DDO8TT Wiring Diagram

The following diagram shows the connection of the outputs module (on the left) and the transistor output wiring (*see page 30*) (on the right).

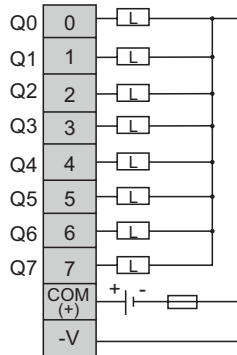

Connect an appropriate fuse for the load, not to exceed 4 A.

⚠ WARNING

UNINTENDED EQUIPMENT OPERATION

Do not connect wires to unused terminals or terminals marked “Not Connected (N.C.)”.

Failure to follow these instructions can result in death, serious injury, or equipment damage.

TM2DDO16UK Digital Transistor Output Module

12

Overview

This chapter describes the TM2DDO16UK module, its characteristics and its connection to the different sensors.

What's in this Chapter?

This chapter contains the following topics:

Topic	Page
Presentation of the TM2DDO16UK Module	94
Characteristics of the TM2DDO16UK Module	95
Connecting the TM2DDO16UK Module	97

Presentation of the TM2DDO16UK Module

TM2DDO16UK Main Characteristics

Output points and common lines	16 transistor outputs in 1 common line
Signal type output	Sink
Output voltage	24 Vdc
Connection type	HE10 connector

Characteristics of the TM2DDO16UK Module

Introduction

This section provides a description of the power limitation, the electrical and the output characteristics of the TM2DDO16UK module.

See also Environmental Characteristics (see page 35).

⚠ DANGER

FIRE HAZARD

Use only the recommended wire sizes for I/O channels and power supplies.

Failure to follow these instructions will result in death or serious injury.

⚠ WARNING

UNINTENDED EQUIPMENT OPERATION

Do not exceed any of the rated values specified in the following tables.

Failure to follow these instructions can result in death, serious injury, or equipment damage.

Dimensions

The following diagrams show the dimensions for the TM2DDO16UK module.

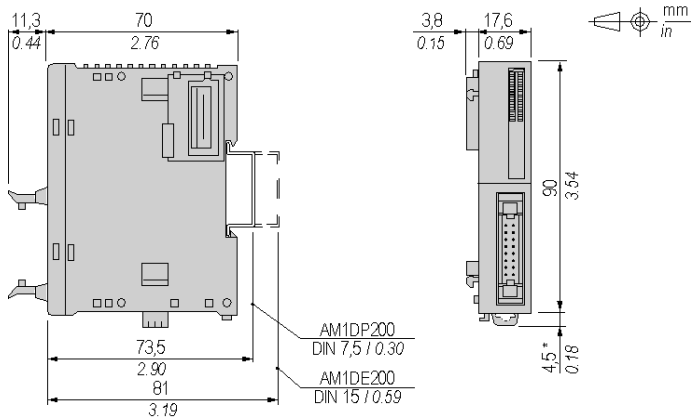

NOTE: * 8.5 mm (0.33 in) when the clamp is pulled out.

TM2DDO16UK Electrical Characteristics

Isolation between output and internal bus	500 Vac
Isolation between output terminal	not isolated
Connector insertion/removal durability	Over 100 times
Current draw on 5 Vdc internal bus	10 mA (all outputs on) 5 mA (all outputs off)
Current draw on 24 Vdc internal bus	40 mA (all outputs on) 0 mA (all outputs off)

TM2DDO16UK Output Characteristics

Output channels	16
Common lines	1 common line for 16 channels
Output current	0.12 A max per output 2 A max per common line
Output voltage	24 Vdc
Output voltage range	20.4...28.8 Vdc
Voltage drop	0.4 Vdc max
Turn on time	300 μ s
Turn off time	300 μ s
Protection against overload and short circuit	External fuse (fast blow, 0.125 A Max)
Protection against reverse polarity	Not protected

Connecting the TM2DDO16UK Module

Introduction

TM2DDO16UK is a 16-channel, transistor output module.
This module is fitted with an HE10 connector for the connection of outputs.

Wiring Rules

See Wiring Requirements (see page 28).

TM2DDO16UK Wiring Diagram

The following diagram shows the connection of the outputs module and the transistor output wiring (see page 30).

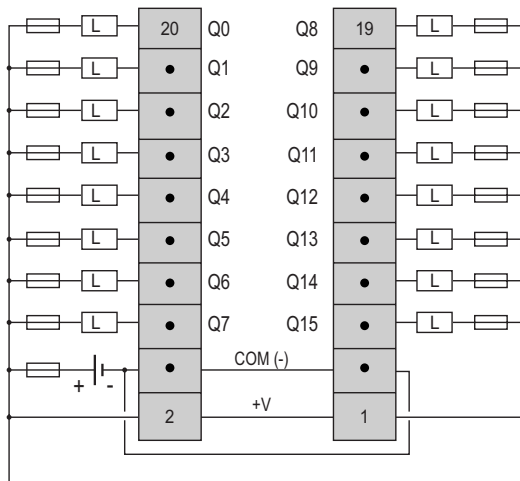

- The COM0(-) terminals are connected together internally.
- The +V terminals are connected together internally.
- Connect an appropriate fuse for the load, not to exceed 0.125 A on the outputs and not to exceed 2 A on the power supply.

⚠ WARNING

UNINTENDED EQUIPMENT OPERATION

Do not connect wires to unused terminals or terminals marked "Not Connected (N.C.)".

Failure to follow these instructions can result in death, serious injury, or equipment damage.

TM2DDO16TK Digital Transistor Output Module

13

Overview

This chapter describes the TM2DDO16TK module, its characteristics and its connection to the different sensors.

What's in this Chapter?

This chapter contains the following topics:

Topic	Page
Presentation of the TM2DDO16TK Module	100
Characteristics of the TM2DDO16TK Module	101
Connecting the TM2DDO16TK Module	103

Presentation of the TM2DDO16TK Module

TM2DDO16TK Main Characteristics

Output points and common lines	16 transistor outputs in 1 common line
Signal type output	Source
Output voltage	24 Vdc
Connection type	HE10 connector

Characteristics of the TM2DDO16TK Module

Introduction

This section provides a description of the power limitation, the electrical and the output characteristics of the TM2DDO16TK module.

See also Environmental Characteristics (see page 35).

⚠ DANGER

FIRE HAZARD

Use only the recommended wire sizes for I/O channels and power supplies.

Failure to follow these instructions will result in death or serious injury.

⚠ WARNING

UNINTENDED EQUIPMENT OPERATION

Do not exceed any of the rated values specified in the following tables.

Failure to follow these instructions can result in death, serious injury, or equipment damage.

Dimensions

The following diagrams show the dimensions for the TM2DDO16TK module.

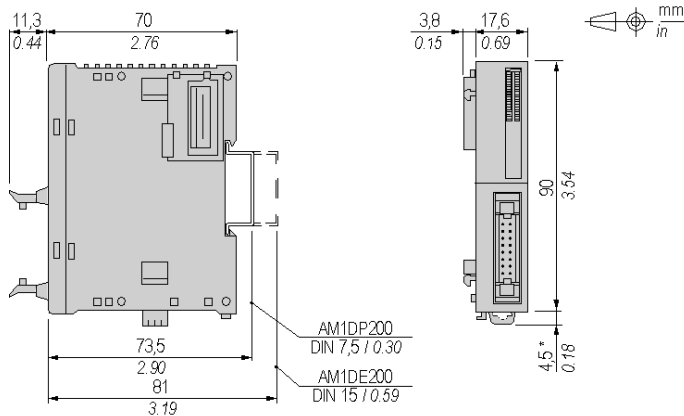

NOTE: * 8.5 mm (0.33 in) when the clamp is pulled out.

TM2DDO16TK Electrical Characteristics

Isolation between output and internal bus	500 Vac
Isolation between output terminals	not isolated
Connector insertion/removal durability	Over 100 times
Current draw on 5 Vdc internal bus	15 mA (all outputs on) 5 mA (all outputs off)
Current draw on 24 Vdc internal bus	20 mA (all outputs on) 0 mA (all outputs off)

TM2DDO16TK Output Characteristics

Output channels	16
Common lines	1 common line for 16 channels
Output current	0.4 A max per output 2 A max per common line
Output voltage	24 Vdc
Output voltage range	20.4...28.8 Vdc
Voltage drop	0.4 Vdc max
Turn on time	450 μ s
Turn off time	450 μ s
Output protection against overcurrent and short circuit	Current limitation $I < 1.7$ A 16 outputs switch off Automatic restart when temperature decreases
Protection against reverse polarity	Yes

Connecting the TM2DDO16TK Module

Introduction

TM2DDO16TK is a 16-channel, transistor output module.
 This module is fitted with an HE10 connector for the connection of outputs.

Wiring Rules

See Wiring Requirements (see page 28).

TM2DDO16TK Wiring Diagram

The following diagram shows the connection of the outputs module and the transistor output wiring (see page 30).

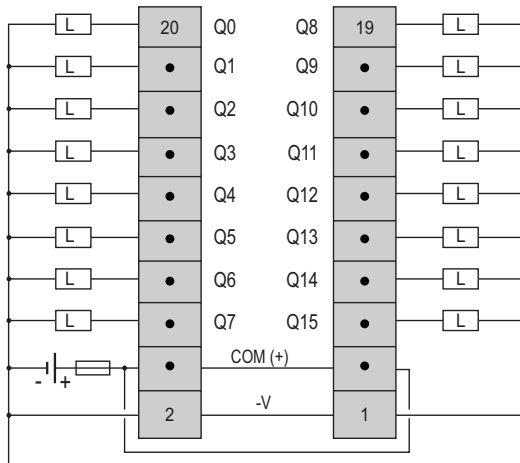

- The COM0(+) terminals are connected together internally.
- The -V terminals are connected together internally.
- Connect an appropriate fuse for the load, not to exceed 0.4 A on the outputs and not to exceed 2 A on the power supply.

⚠ WARNING

UNINTENDED EQUIPMENT OPERATION

Do not connect wires to unused terminals or terminals marked "Not Connected (N.C.)".

Failure to follow these instructions can result in death, serious injury, or equipment damage.

TM2DDO32UK Digital Transistor Output Module

14

Overview

This chapter describes the TM2DDO32UK module, its characteristics and its connection to the different sensors.

What's in this Chapter?

This chapter contains the following topics:

Topic	Page
Presentation of the TM2DDO32UK Module	106
Characteristics of the TM2DDO32UK Module	107
Connecting the TM2DDO32UK Module	109

Presentation of the TM2DDO32UK Module

TM2DDO32UK Main Characteristics

Output points and common lines	32 transistor outputs in 2 common lines
Signal type output	Sink
Output voltage	24 Vdc
Connection type	HE10 connector

Characteristics of the TM2DDO32UK Module

Introduction

This section provides a description of the power limitation, the electrical and the output characteristics of the TM2DDO32UK module.

See also Environmental Characteristics (see page 35).

⚠ DANGER

FIRE HAZARD

Use only the recommended wire sizes for I/O channels and power supplies.

Failure to follow these instructions will result in death or serious injury.

⚠ WARNING

UNINTENDED EQUIPMENT OPERATION

Do not exceed any of the rated values specified in the following tables.

Failure to follow these instructions can result in death, serious injury, or equipment damage.

Dimensions

The following diagrams show the dimensions for the TM2DDO32UK module.

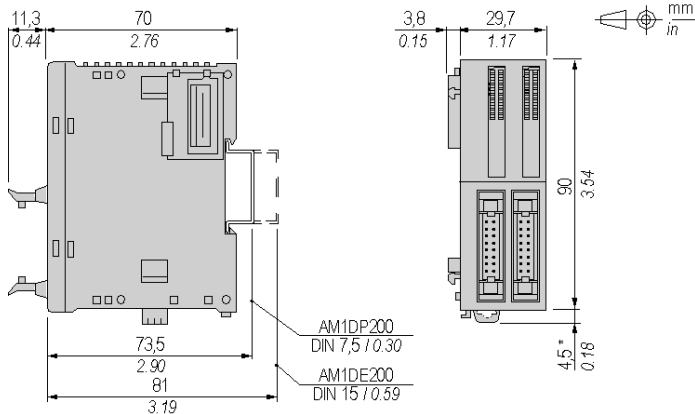

NOTE: * 8.5 mm (0.33 in) when the clamp is pulled out.

TM2DDO32UK Electrical Characteristics

Isolation between output internal bus	500 Vac
Isolation between output terminal	Not isolated
Connector insertion/removal durability	Over 100 times
Current draw on 5 Vdc internal bus	20 mA (all outputs on) 10 mA (all outputs off)
Current draw on 24 Vdc internal bus	70 mA (all outputs on) 0 mA (all outputs off)

TM2DDO32UK Output Characteristics

Output channels	32
Common lines	1 common line for 16 channels
Output current	0.12 A max per output
	2 A max per common line
Output voltage	24 Vdc
Output voltage range	20.4...28.8 Vdc
Voltage drop	0.4 Vdc max
Turn on time	300 μ s
Turn off time	300 μ s
Protection against overload and short circuit	External fuse (fast blow, 0.125 A Max)
Protection against reverse polarity	Not protected

Connecting the TM2DDO32UK Module

Introduction

TM2DDO32UK is a 32-channel, transistor output module. This module is fitted with an HE10 connector for the connection of outputs.

Wiring Rules

See Wiring Requirements (*see page 28*).

TM2DDO32UK Wiring Diagram

The following diagram shows the connection of the outputs module and the transistor output wiring (*see page 30*).

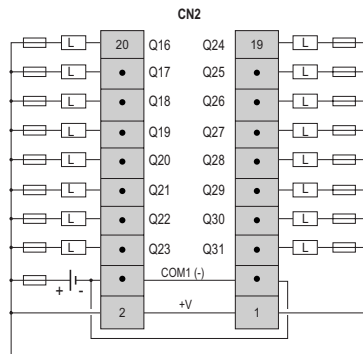
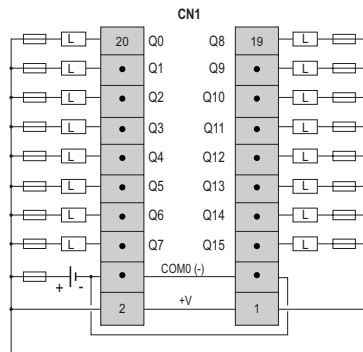

- Terminals on CN1 and CN2 are **not** connected together internally.
- The COM0(-) terminals are connected together internally.
- The COM1(-) terminals are connected together internally.
- The +V terminals are connected together internally.
- Connect an appropriate fuse for the load not to exceed 0.125 A on the outputs and 2 A on the power supply.

 **WARNING**

UNINTENDED EQUIPMENT OPERATION

Do not connect wires to unused terminals or terminals marked “Not Connected (N.C.)”.

Failure to follow these instructions can result in death, serious injury, or equipment damage.

TM2DDO32TK Digital Transistor Output Module

15

Overview

This chapter describes the TM2DDO32TK module, its characteristics and its connection to the different sensors.

What's in this Chapter?

This chapter contains the following topics:

Topic	Page
Presentation of the TM2DDO32TK Module	112
Characteristics of the TM2DDO32TK Module	113
Connecting the TM2DDO32TK Module	115

Presentation of the TM2DDO32TK Module

TM2DDO32TK Main Characteristics

Output points and common lines	32 transistor outputs in 2 common lines
Signal type output	Source
Output voltage	24 Vdc
Connection type	HE10 connector

Characteristics of the TM2DDO32TK Module

Introduction

This section provides a description of the power limitation, the electrical and the output characteristics of the TM2DDO32TK module.

See also Environmental Characteristics (see page 35).

⚠ DANGER

FIRE HAZARD

Use only the recommended wire sizes for I/O channels and power supplies.

Failure to follow these instructions will result in death or serious injury.

⚠ WARNING

UNINTENDED EQUIPMENT OPERATION

Do not exceed any of the rated values specified in the following tables.

Failure to follow these instructions can result in death, serious injury, or equipment damage.

Dimensions

The following diagrams show the dimensions for the TM2DDO32TK module.

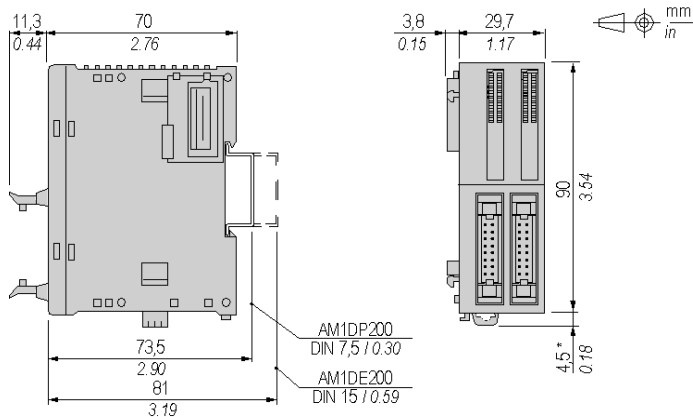

NOTE: * 8.5 mm (0.33 in) when the clamp is pulled out.

TM2DDO32TK Electrical Characteristics

Isolation between output and internal bus	500 Vac
Isolation between output terminals	Not isolated
Connector insertion/removal durability	Over 100 times
Current draw on 5 Vdc internal bus	25 mA (all outputs on) 10 mA (all outputs off)
Current draw on 24 Vdc internal bus	40 mA (all outputs on) 0 mA (all outputs off)

TM2DDO32TK Output Characteristics

Output channels	32
Common lines	1 common line for 16 channels
Output current	0.4 A max per output 2 A max per common line
Output voltage	24 Vdc
Output voltage range	20.4...28.8 Vdc
Voltage drop	0.4 Vdc max
Turn on time	450 μ s
Turn off time	450 μ s
Output protection against overcurrent and short circuit	Current limitation $I < 1.7$ A 32 outputs switch off Automatic restart when temperature decreases
Protection against reverse polarity	Yes

Connecting the TM2DDO32TK Module

Introduction

TM2DDO32TK is a 32-channel, transistor output module.

This module is fitted with an HE10 connector for the connection of outputs.

Wiring Rules

See Wiring Requirements (*see page 28*).

TM2DDO32TK Wiring Diagram

The following diagram shows the connection of the outputs module and the transistor output wiring (*see page 30*).

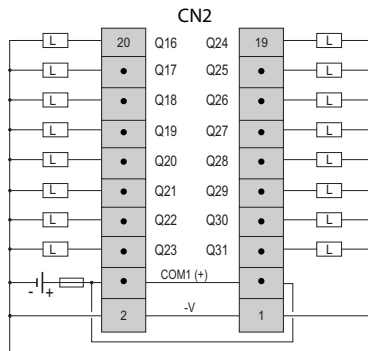
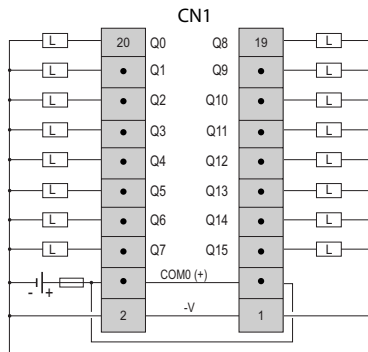

- Terminals CN1 and CN2 are **not** connected together internally.
- The COM0(+) terminals are connected together internally.
- The COM1(+) terminals are connected together internally.
- The -V terminals are connected together internally.
- Connect an appropriate fuse for the load, not to exceed 0.4 A on the outputs and 2 A on the power supply.

 WARNING

UNINTENDED EQUIPMENT OPERATION

Do not connect wires to unused terminals or terminals marked “Not Connected (N.C.)”.

Failure to follow these instructions can result in death, serious injury, or equipment damage.

TM2DMM8DRT Digital Mixed I/O Module

16

Overview

This chapter describes the TM2DMM8DRT module, its characteristics and its connection to the different sensors.

What's in this Chapter?

This chapter contains the following topics:

Topic	Page
Presentation of the TM2DMM8DRT Module	118
Characteristics of the TM2DMM8DRT Module	119
Connecting the TM2DMM8DRT Module	123

Presentation of the TM2DMM8DRT Module

TM2DMM8DRT Main Characteristics

Connection type	Removable screw terminal block
Inputs	
Number of input channels	4
Input type	Type 1
Signal type input	Sink/Source
Rated input voltage	24 Vdc
Outputs	
Output points and common lines	4 contacts on 1 common line
Output type	Relay (NO contacts)
Output Voltage/current	24 Vdc/2 A max 240 Vac/2 A max

Characteristics of the TM2DMM8DRT Module

Introduction

This section provides a description of the power limitation, the electrical, the input and the output characteristics of the TM2DMM8DRT module.

See also Environmental Characteristics (see page 35).

⚠ DANGER

FIRE HAZARD

Use only the recommended wire sizes for I/O channels and power supplies.

Failure to follow these instructions will result in death or serious injury.

⚠ WARNING

UNINTENDED EQUIPMENT OPERATION

Do not exceed any of the rated values specified in the following tables.

Failure to follow these instructions can result in death, serious injury, or equipment damage.

Dimensions

The following diagrams show the dimensions for the TM2DMM8DRT module.

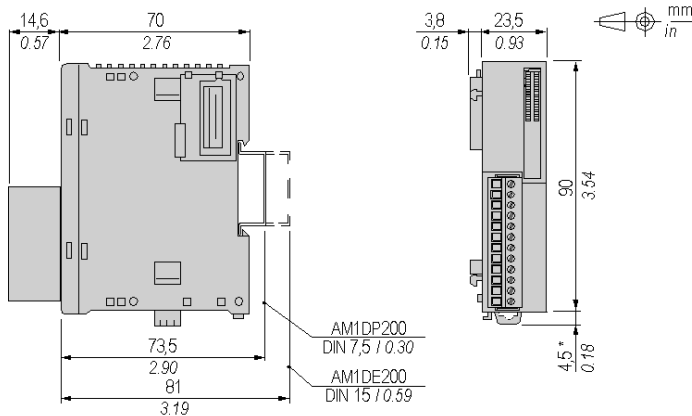

NOTE: * 8.5 mm (0.33 in) when the clamp is pulled out.

TM2DMM8DRT Electrical Characteristics

Connector insertion/removal durability	Over 100 times
Current draw on 5 Vdc internal bus	25 mA (all inputs and outputs on) 5 mA (all inputs and outputs off)
Current draw on 24 Vdc internal bus	20 mA (all inputs and outputs on) 0 mA (all inputs and outputs off)

TM2DMM8DRT Input Characteristics

Number of input channels	4
Common lines	1
Input signals type	sink or source
Rated input voltage	24 Vdc
Input voltage range	20.4...28.8 Vdc
Rated input current at 24 Vdc	7 mA
Input impedance	3.4 kΩ
OFF state	U<5 Vdc
ON state	U>15 Vdc I>2 mA
Turn on time	4 ms
Turn off time	4 ms
Isolation between input internal bus	500 Vac
Isolation Between input terminals	No
Input type	Type 1 (IEC 61131-2)

TM2DMM8DRT Output Characteristics

Output channels	4
Common lines	1 common line for 4 channels
Output current	2 A max per output 7 A max per common line
Rated voltage	24 Vdc 230 / 240 Vac
Max voltage	30 Vdc 264 Vac
In rush current	2 A max

Minimum switching load	0.1 mA 0.1 Vdc
Contact resistance	45 mΩ max
Mechanical life	20 million operations minimum (no load 1,800 operations/h)
Resistive load Inductive load Capacitive load	See Power Limitation below
Isolation between output and internal bus	2300 Vac
Isolation between output and 0V terminals	1500 Vac
Isolation between output groups	1500 Vac
Turn time on	12 ms
Turn time off	10 ms

Usage Limits

When using TM2DMM8DRT:

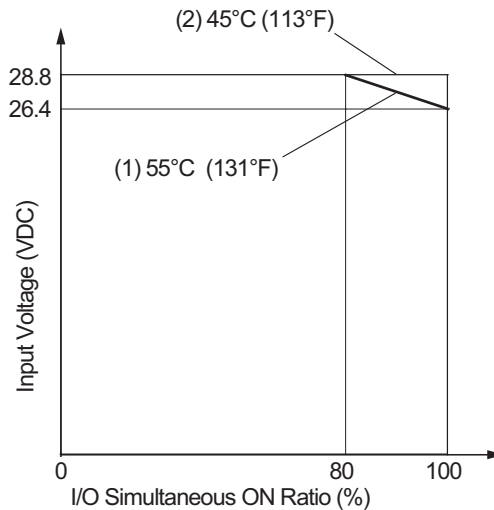

- 1 At an ambient temperature of 55°C (131°F) in the normal mounting direction, limit the inputs and outputs, respectively, which turn on simultaneously along line.
- 2 At 45°C (113°F), all inputs and outputs can be turned on simultaneously at 28.8 Vdc as indicated with line.

TM2DMM8DRT Power Limitation

The following table shows the power limitation of the TM2DMM8DRT module depending on the voltage, the type of load and the number of operations required. Capacitive loads are not supported by this module:

 **WARNING**

RELAY OUTPUTS WELDED CLOSED

- Always protect relay outputs from inductive alternating current load damage using an appropriate external protective circuit or device.
- Do not connect relay outputs to capacitive loads.

Failure to follow these instructions can result in death, serious injury, or equipment damage.

Voltage	24 Vdc	120 Vdc	240 Vdc	Number of operations
Power of resistive loads AC-12		240 VA 80 VA	480 VA 160 VA	100,000 300,000
Power of inductive loads AC-15 (cos α =0.3)		60 VA 18 VA	120 VA 36 VA	100,000 300,000
Power of inductive loads AC-14 (cos α =0.7)		120 VA 36 VA	240 VA 72 VA	100,000 300,000
Power of resistive loads DC-12	48 W 16 W			100,000 300,000
Power of inductive loads DC-13 L/R=7ms	24 W 7.2 W			100,000 300,000

Connecting the TM2DMM8DRT Module

Introduction

TM2DMM8DRT is a 4-channel input/4-channel output, mixed I/O module.

This module is fitted with a removable connection screw terminal block for the connection of inputs, outputs and power supply.

Wiring Rules

See Wiring Requirements (*see page 28*).

TM2DMM8DRT Wiring Diagram

The following diagram shows the connection of the inputs module to the sensors (on the left) and the connection of the outputs with the relay output wiring (*see page 30*) (on the right).

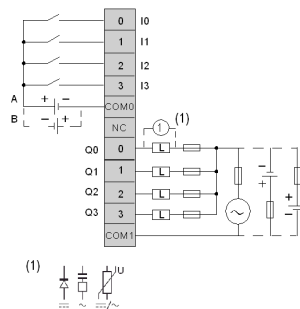

- The COM0 and COM1 terminals are **not** connected together internally.
- Both sink and source input wiring are supported
- A is the sink wiring (positive logic).
- B is the source wiring (negative logic).
- Connect an appropriate fuse for the load, not to exceed 2 A on the outputs and 7 A on the output power supply.
- (1) is the protection for inductive load.

⚠ WARNING

UNINTENDED EQUIPMENT OPERATION

Do not connect wires to unused terminals or terminals marked "Not Connected (N.C.)".

Failure to follow these instructions can result in death, serious injury, or equipment damage.

TM2DMM24DRF Digital Mixed I/O Module

17

Overview

This chapter describes the TM2DMM24DRF module, its characteristics and its connection to the different sensors.

What's in this Chapter?

This chapter contains the following topics:

Topic	Page
Presentation of the TM2DMM24DRF Module	126
Characteristics of the TM2DMM24DRF Module	127
Connecting the TM2DMM24DRF Module	132

Presentation of the TM2DMM24DRF Module

TM2DMM24DRF Main Characteristics

Connection type	Non removable spring terminal block
Inputs	
Number of input channels	16
Input type	Type 1
Signal type input	Sink/Source
Rated input voltage	24 Vdc
Outputs	
Output points and common lines	2 common lines with 8 contacts each
Output type	Relay (NO contacts)
Output Voltage/current	24 Vdc/2 A max. 240 Vac/2 A max.

Characteristics of the TM2DMM24DRF Module

Introduction

This section provides a description of the power limitation, the electrical, the input and the output characteristics of the TM2DMM24DRF module.

See also Environmental Characteristics (see page 35).

DANGER

FIRE HAZARD

Use only the recommended wire sizes for I/O channels and power supplies.

Failure to follow these instructions will result in death or serious injury.

WARNING

UNINTENDED EQUIPMENT OPERATION

Do not exceed any of the rated values specified in the following tables.

Failure to follow these instructions can result in death, serious injury, or equipment damage.

Rules

The table below shows the characteristics of the non-removable spring terminal blocks:

Characteristic		Available
Type of terminal blocks		Spring terminal blocks
Number of wires accommodated		1
Wire gauges accommodated	minimum	0.5 mm ² (20 AWG)
	maximum	1 mm ² (18 AWG)
Wiring constraints		To insert and remove wires from the connectors, use a 2,5 x 0,4 mm (0.10 x 0.02 in) screwdriver to open the round receptacle by pushing on the corresponding plate. Push the flexible plate down on the outside (the side closest to the corresponding receptacle). A screwing (rotating) or bending motion is not required.

Dimensions

The following diagrams show the dimensions for the TM2DMM24DRF module.

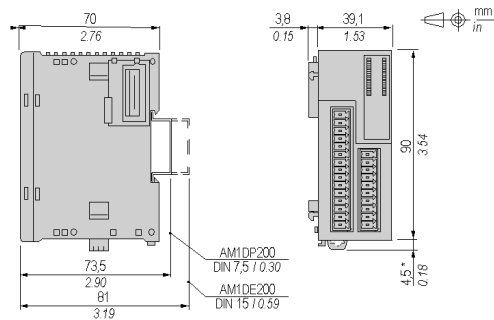

NOTE: * 8.5 mm (0.33 in) when the clamp is pulled out.

TM2DMM24DRF Electrical Characteristics

Current draw on 5 Vdc internal bus	70 mA (all inputs and outputs on) 10 mA (all inputs and outputs off)
Current draw on 24 Vdc internal bus	40 mA (all inputs and outputs on) 0 mA (all inputs and outputs off)

TM2DMM24DRF Input Characteristics

Number of input channels	16
Common lines	1
Input signals type	sink or source
Rated input voltage	24 Vdc
Input voltage range	20.4...28.8 Vdc
Rated input current at 24 Vdc	7 mA
Input impedance	3.4 kΩ
OFF state	U<5 Vdc
ON state	U>15 Vdc I>2 mA
Turn on time	4 ms
Turn off time	4 ms
Isolation between input and internal bus	500 Vac
Isolation between input terminals	Not isolated
Input type	Type 1 (IEC 61131-2)

TM2DMM24DRF Output Characteristics

Output channels	8
Common lines	1 common line for 4 channels
Output current	2 A max per output
	7 A max per common line
Rated voltage	24 Vdc 230 / 240 Vac
Max voltage	30 Vdc 264 Vac
In rush current	2 A max
Minimum switching load	0.1 mA
	0.1 Vdc
Contact resistance	45 mΩ max
Mechanical life	20 million operations minimum (no load 1,800 operations/h)
Resistive load Inductive load Capacitive load	See Power Limitation below
Isolation between output and internal bus	2300 Vac
Isolation between output and 0V terminals	1500 Vac
Isolation between output groups	1500 Vac
Turn on time	12 ms
Turn off time	10 ms

Usage Limits

When using TM2DMM24DRF:

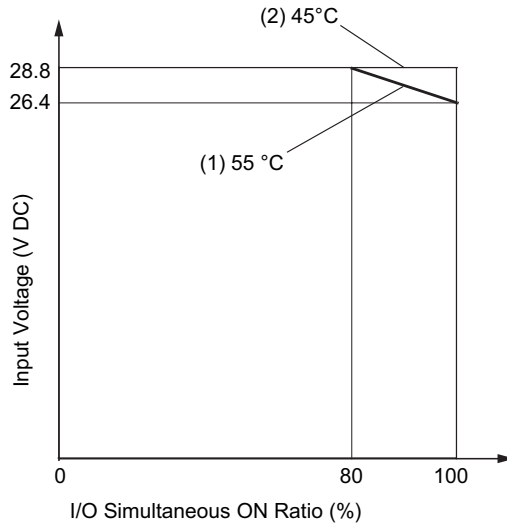

- 1 At an ambient temperature of 55°C (131°F) in the normal mounting direction, limit the inputs and outputs, respectively, which turn on simultaneously along line.
- 2 At 45°C (113°F), all inputs and outputs can be turned on simultaneously at 28.8 Vdc as indicated with line.

TM2DMM24DRF Power Limitation

The following table shows the power limitation of the TM2DMM24DRF module depending on the voltage, the type of load and the number of operations required.

Capacitive loads are not supported by this module:

 **WARNING**

RELAY OUTPUTS WELDED CLOSED

- Always protect relay outputs from inductive alternating current load damage using an appropriate external protective circuit or device.
- Do not connect relay outputs to capacitive loads.

Failure to follow these instructions can result in death, serious injury, or equipment damage.

Voltage	24 Vdc	120 Vac	240 Vac	Number of operations
Power of resistive loads AC-12		240 VA 80 VA	480 VA 160 VA	100,000 300,000
Power of inductive loads AC-15 (cos x=0.3)		60 VA 18 VA	120 VA 36 VA	100,000 300,000
Power of inductive loads AC-14 (cos x=0.7)		120 VA 36 VA	240 VA 72 VA	100,000 300,000
Power of resistive loads DC-12	48 W 16 W			100,000 300,000
Power of inductive loads DC-13 L/R=7ms	24 W 7.2 W			100,000 300,000

Connecting the TM2DMM24DRF Module

Introduction

TM2DMM24DRF is a 16-channel input/8-channel output, mixed I/O module.

This module is fitted with a non removable connection spring terminal block for the connection of inputs, outputs and power supply.

Wiring Rules

See Wiring Requirements (see page 28).

TM2DMM24DRF Wiring Diagram

The following diagram shows the connection of the inputs module to the sensors (on the left) and the connection of the outputs with the relay output wiring (see page 30) (on the right).

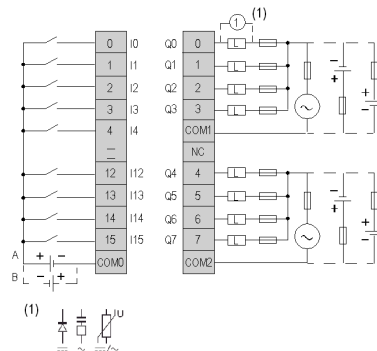

- The COM0, COM1 and COM2 terminals are **not** connected together internally.
- Connect an appropriate fuse for the load, not to exceed 2 A on the outputs and 7 A on the output power supply.
- Both sink and source input wiring are supported
- A is the sink wiring (positive logic).
- B is the source wiring (negative logic).
- (1) is the protection for inductive load.

⚠ WARNING

UNINTENDED EQUIPMENT OPERATION

Do not connect wires to unused terminals or terminals marked “Not Connected (N.C.)”.

Failure to follow these instructions can result in death, serious injury, or equipment damage.

Certifications and Standards

18

Certifications and Standards

Introduction

TM2 digital I/O modules comply with the main national and international standards concerning electronic industrial control devices.

Reference	CE	TüV IEC EN 61131-2 edition 2 2003	UL	CSA	UL / CSA Class I, Div. 2	Nemko - GL - LR - DNV ABS - BV
TM2DAI8DT	X	–	X	X	X	–
TM2DDI16DK	X	X	X	X	X	X
TM2DDI16DT	X	X	X	X	X	X
TM2DDI32DK	X	X	X	X	X	X
TM2DDI8DT	X	X	X	X	X	X
TM2DDO16TK	X	X	X	X	X	X
TM2DDO16UK	X	X	X	X	X	X
TM2DDO32TK	X	X	X	X	X	X
TM2DDO32UK	X	X	X	X	X	X
TM2DDO8TT	X	X	X	X	X	X
TM2DDO8UT	X	X	X	X	X	X
TM2MM24DRF	X	X	X	X	X	X
TM2MM8DRT	X	X	X	X	X	X
TM2DRA16RT	X	X	X	X	X	X
TM2DRA8RT	X	X	X	X	X	X

Glossary

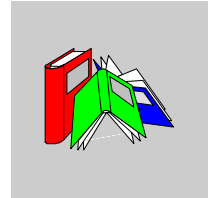

A

analog input

An *analog input* module contains circuits that convert an analog DC input signal to a digital value that can be manipulated by the processor. By implication, the analog input is usually direct. That means a data table value directly reflects the analog signal value.

analog output

An *analog output* module contains circuits that transmit an analog DC signal proportional to a digital value input to the module from the processor. By implication, these analog outputs are usually direct. That means a data table value directly controls the analog signal value.

AWG

The *american wire gauge* standard specifies wire gauges in North America.

D

De-rating

De-rating describes a reduction in an operating specification. For devices in general it is usually a specified reduction in nominal power to facilitate operation at increased ambient conditions like higher temperatures or higher altitudes.

digital I/O

A *digital input or output* has an individual circuit connection at the electronic module that corresponds directly to a data table bit that holds the value of the signal at that I/O circuit. It gives the control logic digital access to I/O values.

DIN

Deutsches Institut für Normung is a German institution that sets engineering and dimensional standards.

E

expansion connector

A connector to attach expansion I/O modules.

expansion connector sticker

A cover to protect the expansion connector.

expansion I/O module

An *expansion input or output module* is either a digital or analog module that adds additional I/O to the base controller.

expert I/O

Expert I/Os are dedicated modules or channels for advanced features. These features are generally embedded in the module in order to not use the resources of the PLC Controller and to allow a fast response time, depending of the feature. Regarding the function, it could be considered as a “stand alone” module, because the function is independent of the Controller processing cycle, it just exchanges some information with the Controller CPU.

F

FE

Functional ground is the point of a system or device that must be grounded to help prevent equipment damage.

FG

frequency generator

free wire

The end of a digital I/O cable whose wires do not have a connector. This scheme provides connectivity from controller to digital I/O points.

H**HSC**

high-speed counter.

I**I/O**

input/output

I/O terminals

An *input/output terminal* on the front of an expansion I/O module connects input and output signals.

IEC

The *international electrotechnical commission* is a non-profit and non-governmental international standards organization that prepares and publishes international standards for all electrical, electronic, and related technologies.

input filter

An *input filter* is a special function that rejects input noises. It is useful for eliminating input noises and chatter in limit switches. All inputs provide a level of input filtering using the hardware. Additional filtering with software is also configurable through the programing or the configuration software.

input terminals

An *input terminal* on the front of an expansion I/O module connects input signals from input devices (such as sensors, push buttons, and limit switches). For some modules, input terminals accept both sink and source DC input signals.

IP 20

Ingress protection rating according to IEC 60529. IP20 modules are protected against ingress and contact of objects larger than 12.5 mm. The module is not protected against harmful ingress of water.

L

LED

A *light emitting diode* is an indicator that lights up when electricity passes through it.

N

NC

A *normally closed* contact is a contact pair that is closed when the actuator is de-energized (no power is applied) and open when the actuator is energized (power is applied).

NO

A *normally open* contact is a contact pair that is open when the actuator is de-energized (no power is applied) and closed when the actuator is energized (power is applied).

O

output terminals

An *output terminal* connects output signals to output devices (such as electromechanical relays and solenoid valves).

P

PE

Protective ground is a return line across the bus for fault currents generated at a sensor or actuator device in the control system.

Pt100/Pt1000

Platinum resistance thermometer are characterized by their nominal resistance R_0 at a temperature of 0°C .

- Pt100 ($R_0 = 100 \text{ Ohm}$)
- Pt1000 ($R_0 = 1 \text{ kOhm}$)

S

sink input

A *sink input* is a wiring arrangement in which the device provides current to the input electronic module. A sink input is referenced to 0 Vdc .

source output

A *source output* is a wiring arrangement in which the output electronic module provides current to the device. A source output is referenced to $+24 \text{ Vdc}$.

Index

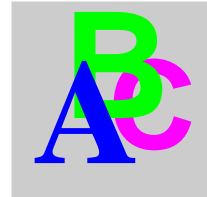

A

- Accessories, *18*
- Assembling to a controller, *22*

C

- Cables
 - Digital I/O cables, *18*
 - Telefast cables, *18*
- certifications and standards, *133*
- Controllers
 - Disassembling a module, *24*

D

- Digital I/O modules, *15*
 - Physical description, *17*
 - Specifications, *15*

Dimensions

- TM2DAI8DT, *39*
- TM2DDI16DK, *57*
- TM2DDI16DT, *51*
- TM2DDI32DK, *63*
- TM2DDI8DT, *45*
- TM2DDO16TK, *101*
- TM2DDO16UK, *95*
- TM2DDO32TK, *113*
- TM2DDO32UK, *107*
- TM2DDO8TT, *89*
- TM2DDO8UT, *83*
- TM2DMM24DRF, *128*
- TM2DMM8DRT, *119*
- TM2DRA16RT, *75*
- TM2DRA8RT, *69*

DIN rail

- 15 mm AM1DE200 rail, *19*
- 7,5 mm AM1DP200 rail, *19*

M

- Mounting Position, *21*

P

Physical description

- Connector HE10, 17
- Terminal block, 17

Power limitation

- TM2DMM24DRF, 130
- TM2DMM8DRT, 122
- TM2DRA16RT, 77
- TM2DRA8RT, 71

S

Specifications

- Digital I/O modules, 15

T

Terminal block end clamp type AB1AB8P35, 18

TM2 I/O modules

- Environmental Characteristics, 35
 - wiring requirements, 28
- TM2DAI8DT, 37, 38, 39, 41
- TM2DDI16DK, 55, 56, 57, 59
- TM2DDI16DT, 49, 50, 51, 53
- TM2DDI32DK, 61, 62, 63, 65
- TM2DDI8DT, 43, 44, 45, 48
- TM2DDO16TK, 99, 100, 101
- TM2DDO16UK, 93, 94, 95
- TM2DDO32TK, 111, 112, 113
- TM2DDO32UK, 105, 106, 107
- TM2DDO8TT, 87, 88, 89
- TM2DDO8UT, 81, 82, 83
- TM2DMM24DRF, 125, 126, 127
- TM2DMM8DRT, 117, 118, 119
- TM2DRA16RT, 73, 74, 75
- TM2DRA8RT, 67, 68, 69
- TWDXMT5 mounting strip, 19

U

Usage limits

- TM2DDI16DK, 58
- TM2DDI16DT, 52
- TM2DDI32DK, 64
- TM2DDI8DT, 47
- TM2DMM24DRF, 130
- TM2DMM8DRT, 121

W

Wiring diagram

- TM2DAI8DT, 41
- TM2DDI16DK, 59
- TM2DDI16DT, 53
- TM2DDI32DK, 65
- TM2DDI8DT, 48