

Modicon TM2

Analog I/O Modules

Hardware Guide

11/2015



EIO0000000034.07

www.schneider-electric.com

Schneider
Electric

The information provided in this documentation contains general descriptions and/or technical characteristics of the performance of the products contained herein. This documentation is not intended as a substitute for and is not to be used for determining suitability or reliability of these products for specific user applications. It is the duty of any such user or integrator to perform the appropriate and complete risk analysis, evaluation and testing of the products with respect to the relevant specific application or use thereof. Neither Schneider Electric nor any of its affiliates or subsidiaries shall be responsible or liable for misuse of the information contained herein. If you have any suggestions for improvements or amendments or have found errors in this publication, please notify us.

No part of this document may be reproduced in any form or by any means, electronic or mechanical, including photocopying, without express written permission of Schneider Electric.

All pertinent state, regional, and local safety regulations must be observed when installing and using this product. For reasons of safety and to help ensure compliance with documented system data, only the manufacturer should perform repairs to components.

When devices are used for applications with technical safety requirements, the relevant instructions must be followed.

Failure to use Schneider Electric software or approved software with our hardware products may result in injury, harm, or improper operating results.

Failure to observe this information can result in injury or equipment damage.

© 2015 Schneider Electric. All rights reserved.

Table of Contents



	Safety Information	5
	About the Book	7
Chapter 1	General Overview and Rules for Implementing	13
1.1	General Overview	14
	General Description	15
	Physical description	17
	Accessories	18
1.2	General Rules for Implementing	20
	Mounting Positions and Minimum Clearances	21
	Assembling a Module to a Controller	22
	Disassembling a Module from a Controller	24
	Installing and Removing the Controller with Expansions	25
	Mounting a Module Directly on a Panel Surface	26
	Wiring Requirements	28
	Grounding	30
Chapter 2	Environmental Characteristics of TM2 I/O Modules ..	33
	Environmental Characteristics of TM2 I/O Modules	33
Chapter 3	TM2AMI2HT Analog Input Module	35
	Presentation of the TM2AMI2HT Module	36
	Characteristics of the TM2AMI2HT Module	37
	Connecting the TM2AMI2HT Module	41
Chapter 4	TM2AMI2LT Analog Input Module	43
	Presentation of the TM2AMI2LT Module	44
	Characteristics of the TM2AMI2LT Module	45
	Connecting the TM2AMI2LT Module	49
Chapter 5	TM2AMI4LT Analog Input Module	51
	Presentation of the TM2AMI4LT Module	52
	Characteristics of the TM2AMI4LT Module	53
	Connecting the TM2AMI4LT Module	57
Chapter 6	TM2AMI8HT Analog Input Module	59
	Presentation of the TM2AMI8HT Module	60
	Characteristics of the TM2AMI8HT Module	61
	Connecting the TM2AMI8HT Module	64

Chapter 7	TM2ARI8HT Analog Input Module	67
	Presentation of the TM2ARI8HT Module	68
	Characteristics of the TM2ARI8HT Module	69
	Connecting the TM2ARI8HT Module	72
Chapter 8	TM2ARI8LRJ Analog Input Module	75
	Presentation of the TM2ARI8LRJ Module	76
	Characteristics of the TM2ARI8LRJ Module	77
	Connecting the TM2ARI8LRJ Module	81
Chapter 9	TM2ARI8LT Analog Input Module	83
	Presentation of the TM2ARI8LT Module	84
	Characteristics of the TM2ARI8LT Module	85
	Connecting the TM2ARI8LT Module	89
Chapter 10	TM2AMO1HT Analog Output Module	91
	Presentation of the TM2AMO1HT Module	92
	Characteristics of the TM2AMO1HT Module	93
	Connecting the TM2AMO1HT Module	97
Chapter 11	TM2AVO2HT Analog Output Module	99
	Presentation of the TM2AVO2HT Module	100
	Characteristics of the TM2AVO2HT Module	101
	Connecting the TM2AVO2HT Module	104
Chapter 12	TM2AMM3HT Analog Mixed I/O Module	107
	Presentation of the TM2AMM3HT Module	108
	Characteristics of the TM2AMM3HT Module	109
	Connecting the TM2AMM3HT Module	114
Chapter 13	TM2AMM6HT Analog Mixed I/O Module	117
	Presentation of the TM2AMM6HT Module	118
	Characteristics of the TM2AMM6HT Module	119
	Connecting the TM2AMM6HT Module	123
Chapter 14	TM2ALM3LT Analog Mixed I/O Module	125
	Presentation of the TM2ALM3LT Module	126
	Characteristics of the TM2ALM3LT Module	127
	Connecting the TM2ALM3LT Module	132
Chapter 15	Certifications and Standards	135
	Certifications and Standards	135
Glossary	137
Index	139

Safety Information



Important Information

NOTICE

Read these instructions carefully, and look at the equipment to become familiar with the device before trying to install, operate, or maintain it. The following special messages may appear throughout this documentation or on the equipment to warn of potential hazards or to call attention to information that clarifies or simplifies a procedure.



The addition of this symbol to a Danger safety label indicates that an electrical hazard exists, which will result in personal injury if the instructions are not followed.



This is the safety alert symbol. It is used to alert you to potential personal injury hazards. Obey all safety messages that follow this symbol to avoid possible injury or death.

DANGER

DANGER indicates an imminently hazardous situation which, if not avoided, **will result in** death or serious injury.

WARNING

WARNING indicates a potentially hazardous situation which, if not avoided, **can result in** death or serious injury.

CAUTION

CAUTION indicates a potentially hazardous situation which, if not avoided, **can result in** minor or moderate injury.

NOTICE

NOTICE is used to address practices not related to physical injury.

PLEASE NOTE

Electrical equipment should be installed, operated, serviced, and maintained only by qualified personnel. No responsibility is assumed by Schneider Electric for any consequences arising out of the use of this material.

A qualified person is one who has skills and knowledge related to the construction and operation of electrical equipment and its installation, and has received safety training to recognize and avoid the hazards involved.

About the Book



At a Glance

Document Scope

This guide describes the hardware implementation of TM2 Analog I/O Modules. It provides parts descriptions, specifications, wiring diagrams, installation, and setup for TM2 Analog I/O modules.

Validity Note

The information in this manual is applicable **only** for TM2 products.

This document has been updated for the release of SoMachine V4.1 SP2.

This document has been updated for the release of SoMachine Basic V1.4.

For product compliance and environmental information (RoHS, REACH, PEP, EOLI, etc.), go to www.schneider-electric.com/green-premium.

The technical characteristics of the devices described in this document also appear online. To access this information online:

Step	Action
1	Go to the Schneider Electric home page www.schneider-electric.com .
2	In the Search box type the reference of a product or the name of a product range. <ul style="list-style-type: none">• Do not include blank spaces in the reference or product range.• To get information on grouping similar modules, use asterisks (*).
3	If you entered a reference, go to the Product Datasheets search results and click on the reference that interests you. If you entered the name of a product range, go to the Product Ranges search results and click on the product range that interests you.
4	If more than one reference appears in the Products search results, click on the reference that interests you.
5	Depending on the size of your screen, you may need to scroll down to see the data sheet.
6	To save or print a data sheet as a .pdf file, click Download XXX product datasheet .

The characteristics that are presented in this manual should be the same as those characteristics that appear online. In line with our policy of constant improvement, we may revise content over time to improve clarity and accuracy. If you see a difference between the manual and online information, use the online information as your reference.

Related Documents

Title of Documentation	Reference Number
Modicon TM2 Expansion Modules Configuration Programming Guide	EIO0000000396 (ENG); EIO0000000397 (FRE); EIO0000000398 (GER); EIO0000000399 (SPA); EIO0000000400 (ITA); EIO0000000401 (CHS)
M238 Controller Hardware Guide	EIO0000000016 (ENG); EIO0000000017 (FRE); EIO0000000018 (GER); EIO0000000019 (SPA); EIO0000000020 (ITA); EIO0000000021 (CS)
TM2 Digital I/O Modules Instruction Sheet	AAV8177300

You can download these technical publications and other technical information from our website at <http://download.schneider-electric.com>

Product Related Information

 **DANGER**

HAZARD OF ELECTRIC SHOCK, EXPLOSION OR ARC FLASH

- Disconnect all power from all equipment including connected devices prior to removing any covers or doors, or installing or removing any accessories, hardware, cables, or wires except under the specific conditions specified in the appropriate hardware guide for this equipment.
- Always use a properly rated voltage sensing device to confirm the power is off where and when indicated.
- Replace and secure all covers, accessories, hardware, cables, and wires and confirm that a proper ground connection exists before applying power to the unit.
- Use only the specified voltage when operating this equipment and any associated products.

Failure to follow these instructions will result in death or serious injury.

DANGER

POTENTIAL FOR EXPLOSION

- Only use this equipment in non-hazardous locations, or in locations that comply with Class I, Division 2, Groups A, B, C and D.
- Do not substitute components which would impair compliance to Class I Division 2.
- Do not connect or disconnect equipment unless power has been removed or the location is known to be non-hazardous.

Failure to follow these instructions will result in death or serious injury.

WARNING

LOSS OF CONTROL

- The designer of any control scheme must consider the potential failure modes of control paths and, for certain critical control functions, provide a means to achieve a safe state during and after a path failure. Examples of critical control functions are emergency stop and overtravel stop, power outage and restart.
- Separate or redundant control paths must be provided for critical control functions.
- System control paths may include communication links. Consideration must be given to the implications of unanticipated transmission delays or failures of the link.
- Observe all accident prevention regulations and local safety guidelines.¹
- Each implementation of this equipment must be individually and thoroughly tested for proper operation before being placed into service.

Failure to follow these instructions can result in death, serious injury, or equipment damage.

¹ For additional information, refer to NEMA ICS 1.1 (latest edition), "Safety Guidelines for the Application, Installation, and Maintenance of Solid State Control" and to NEMA ICS 7.1 (latest edition), "Safety Standards for Construction and Guide for Selection, Installation and Operation of Adjustable-Speed Drive Systems" or their equivalent governing your particular location.

WARNING

UNINTENDED EQUIPMENT OPERATION

- Only use software approved by Schneider Electric for use with this equipment.
- Update your application program every time you change the physical hardware configuration.

Failure to follow these instructions can result in death, serious injury, or equipment damage.

Terminology Derived from Standards

The technical terms, terminology, symbols and the corresponding descriptions in this manual, or that appear in or on the products themselves, are generally derived from the terms or definitions of international standards.

In the area of functional safety systems, drives and general automation, this may include, but is not limited to, terms such as *safety*, *safety function*, *safe state*, *fault*, *fault reset*, *malfunction*, *failure*, *error*, *error message*, *dangerous*, etc.

Among others, these standards include:

Standard	Description
EN 61131-2:2007	Programmable controllers, part 2: Equipment requirements and tests.
ISO 13849-1:2008	Safety of machinery: Safety related parts of control systems. General principles for design.
EN 61496-1:2013	Safety of machinery: Electro-sensitive protective equipment. Part 1: General requirements and tests.
ISO 12100:2010	Safety of machinery - General principles for design - Risk assessment and risk reduction
EN 60204-1:2006	Safety of machinery - Electrical equipment of machines - Part 1: General requirements
EN 1088:2008 ISO 14119:2013	Safety of machinery - Interlocking devices associated with guards - Principles for design and selection
ISO 13850:2006	Safety of machinery - Emergency stop - Principles for design
EN/IEC 62061:2005	Safety of machinery - Functional safety of safety-related electrical, electronic, and electronic programmable control systems
IEC 61508-1:2010	Functional safety of electrical/electronic/programmable electronic safety-related systems: General requirements.
IEC 61508-2:2010	Functional safety of electrical/electronic/programmable electronic safety-related systems: Requirements for electrical/electronic/programmable electronic safety-related systems.
IEC 61508-3:2010	Functional safety of electrical/electronic/programmable electronic safety-related systems: Software requirements.
IEC 61784-3:2008	Digital data communication for measurement and control: Functional safety field buses.
2006/42/EC	Machinery Directive
2004/108/EC	Electromagnetic Compatibility Directive
2006/95/EC	Low Voltage Directive

In addition, terms used in the present document may tangentially be used as they are derived from other standards such as:

Standard	Description
IEC 60034 series	Rotating electrical machines
IEC 61800 series	Adjustable speed electrical power drive systems
IEC 61158 series	Digital data communications for measurement and control – Fieldbus for use in industrial control systems

Finally, the term *zone of operation* may be used in conjunction with the description of specific hazards, and is defined as it is for a *hazard zone* or *danger zone* in the *EC Machinery Directive (EC/2006/42)* and *ISO 12100:2010*.

NOTE: The aforementioned standards may or may not apply to the specific products cited in the present documentation. For more information concerning the individual standards applicable to the products described herein, see the characteristics tables for those product references.

Chapter 1

General Overview and Rules for Implementing

Introduction

This chapter gives a general introduction and the rules for implementing the TM2 Analog I/O modules.

What Is in This Chapter?

This chapter contains the following sections:

Section	Topic	Page
1.1	General Overview	14
1.2	General Rules for Implementing	20

Section 1.1

General Overview

Introduction

This section gives a general introduction to the modules.

What Is in This Section?

This section contains the following topics:

Topic	Page
General Description	15
Physical description	17
Accessories	18

General Description

Introduction

The range of TM2 analog I/O modules includes:

- Input modules,
- Output modules,
- Mixed Input/Output modules.

The TM2 analog I/O modules are equipped with either screw terminal blocks or RJ11 connectors (only for TM2ARI8LRJ).

Module Features

The following table shows the analog I/O modules features, with corresponding channel type, voltage/current and terminal type:

Reference module	Channels	Channel type	Voltage/current	Terminal Type	Reference page
Input Modules					
TM2AMI2HT	2	High-level inputs	0...10 Vdc 4...20 mA	Removable screw terminal	<i>TM2AMI2HT Analog Input Module, page 35</i>
TM2AMI2LT	2	Low-level inputs	Thermocouple type J,K,T	Removable screw terminal	<i>TM2AMI2LT Analog Input Module, page 43</i>
TM2AMI4LT	4	Inputs	0...10 Vdc 0...20 mA PT100/1000 Ni100/1000	Removable screw terminal	<i>TM2AMI4LT Analog Input Module, page 51</i>
TM2AMI8HT	8	Inputs	0...20 mA 0...10 Vdc	Removable screw terminal	<i>TM2AMI8HT Analog Input Module, page 59</i>
TM2ARI8HT	8	Inputs	NTC / PTC	Removable screw terminal	<i>TM2ARI8HT Analog Input Module, page 67</i>
TM2ARI8LRJ	8	Inputs	PT100/1000	RJ11 connector	<i>TM2ARI8LRJ Analog Input Module, page 75</i>
TM2ARI8LT	8	Inputs	PT100/1000	Removable screw terminal	<i>TM2ARI8LT Analog Input Module, page 83</i>

Reference module	Channels	Channel type	Voltage/current	Terminal Type	Reference page
Output Modules					
TM2AMO1HT	1	Outputs	0...10 Vdc 4...20 mA	Removable screw terminal	<i>TM2AMO1HT Analog Output Module, page 91</i>
TM2AVO2HT	2	Outputs	+/- 10 Vdc	Removable screw terminal	<i>TM2AVO2HT Analog Output Module, page 99</i>
Mixed Modules					
TM2AMM3HT	2	Inputs	0...10 Vdc 4...20 mA	Removable screw terminal	<i>TM2AMM3HT Analog Mixed I/O Module, page 107</i>
	1	Outputs			
TM2AMM6HT	4	Inputs	0...10 Vdc 4...20 mA	Removable screw terminal	<i>TM2AMM6HT Analog Mixed I/O Module, page 117</i>
	2	Outputs			
TM2ALM3LT	2	Low-level inputs	Thermo J,K,T, PT100	Removable screw terminal	<i>TM2ALM3LT Analog Mixed I/O Module, page 125</i>
	1	Outputs			

Physical description

Introduction

This section describes the parts of Analog I/O modules, two with terminal block and one with 8 x RJ11 connectors. Your I/O module may differ from the illustrations but the parts will be the same.

TM2ALM3LT module
with a terminal block

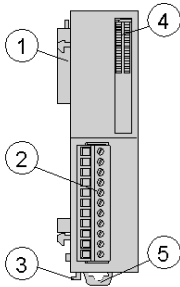

TM2ARI8LT module
with 2 terminal blocks

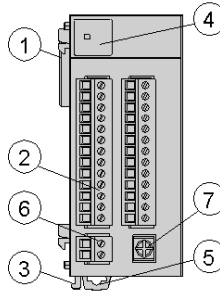

TM2ARI8LRJ module
with 8 x RJ11 connectors

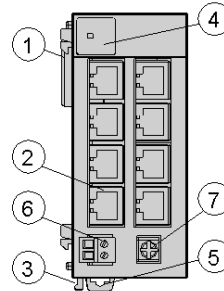

Elements

The following table describes the different elements of Analog I/O modules shown above:

Label	TM2ALM3LT	TM2ARI8LT	TM2ARI8LRJ
1	Expansion connector for electrical connection (one on each side, right side not visible). It is designed to provide continuity of the electrical link between the modules connected.		
2	Terminal block (supplied with the module)	2 x Terminal block (supplied with the module)	8 x RJ11 Connectors
3	Locking device for attachment to the previous module		
4	LEDs for displaying the channels and module diagnostics		
5	Clip-on lock		
6	-	Power supply screw terminal block: 24 Vdc	
7	-	Screw for functional ground	

Accessories

Terminal Block End Clamp Type AB1AB8P35

Terminal Block End Clamps (reference AB1AB8P35) help reduce side-to-side movement of your controller and modules on the mounting rail. A controller and its associated modules are mounted on the mounting rail between two end clamps in order to improve the shock and vibration characteristics of the assembly.

The following picture shows a AB1AB8P35 Terminal Block End Clamp:

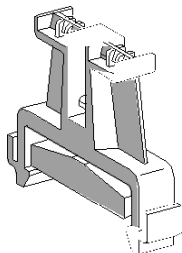

The Mounting Rail

You can mount the controller and its expansion modules on a mounting rail. A mounting rail can be attached to a smooth mounting surface or suspended from an Electronic Industries Alliance (EIA) rack or in a Type 4 cabinet.

The following picture shows the different sizes of the mounting rail:

AM1DE200
IEC/EN 60715

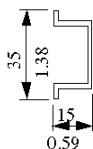

AM1DP200

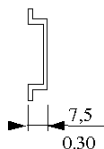

AM1ED200



DZ5MB200



You can order the suitable mounting rail from Schneider Electric:

Rail depth	Catalogue part number
15 mm (0.59 in.)	AM1DE200
7,5 mm (0.30 in.)	AM1DP200

NOTE: Do not use AM1ED200 and DZ5MB200.

TWDXMT5 Panel Mount Kit

The following illustration shows a TWDXMT5 Panel Mount Kit which can be used instead of a mounting rail to mount your controller and I/O modules directly to a panel:

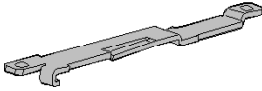

TM2XMTGB Grounding Bar

The TM2XMTGB Grounding Bar is used to connect the shields of the cables and the functional ground of the modules to ground (*see page 30*).

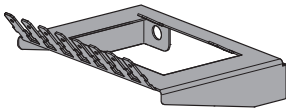

Section 1.2

General Rules for Implementing

Introduction

This section presents the information necessary to install and configure the modules, including mounting, wiring, and grounding requirements.

What Is in This Section?

This section contains the following topics:

Topic	Page
Mounting Positions and Minimum Clearances	21
Assembling a Module to a Controller	22
Disassembling a Module from a Controller	24
Installing and Removing the Controller with Expansions	25
Mounting a Module Directly on a Panel Surface	26
Wiring Requirements	28
Grounding	30

Mounting Positions and Minimum Clearances

Introduction

For mounting positions and minimum clearances, modules are mounted according to the rules defined for the hardware system that you associate with. Refer to the appropriate *Installation* chapter in the system *Hardware* documentation.

WARNING

UNINTENDED EQUIPMENT OPERATION

- Place devices dissipating the most heat at the top of the cabinet and ensure adequate ventilation.
- Avoid placing this equipment next to or above devices that might cause overheating.
- Install the equipment in a location providing the minimum clearances from all adjacent structures and equipment as directed in this document.
- Install all equipment in accordance with the specifications in the related documentation.

Failure to follow these instructions can result in death, serious injury, or equipment damage.

Assembling a Module to a Controller

Introduction

This section describes how to assemble a module to a controller.

After attaching new I/O modules to the controller, it is important to update and re-download your application program before placing the system back in service. If you do not revise your application program to reflect the addition of new modules, I/O located on the expansion bus may no longer operate normally.

DANGER

HAZARD OF ELECTRIC SHOCK, EXPLOSION OR ARC FLASH

- Disconnect all power from all equipment including connected devices prior to removing any covers or doors, or installing or removing any accessories, hardware, cables, or wires except under the specific conditions specified in the appropriate hardware guide for this equipment.
- Always use a properly rated voltage sensing device to confirm the power is off where and when indicated.
- Replace and secure all covers, accessories, hardware, cables, and wires and confirm that a proper ground connection exists before applying power to the unit.
- Use only the specified voltage when operating this equipment and any associated products.

Failure to follow these instructions will result in death or serious injury.

WARNING

UNINTENDED EQUIPMENT OPERATION

- Only use software approved by Schneider Electric for use with this equipment.
- Update your application program every time you change the physical hardware configuration.

Failure to follow these instructions can result in death, serious injury, or equipment damage.

Assembling a Module to a Controller

The following procedure shows how to assemble a controller and a module together.

Step	Action
1	Remove all power and dismount any existing controller/IO assembly from its DIN/panel mounting.
2	Remove the expansion connector sticker from the controller or the outermost installed module.
3	Verify that the locking device (<i>see page 17</i>) on the new module is in the upper position.
4	Align the internal bus connector on the left side of the module with the internal bus connector on the right side of the controller or module.
5	Press the new module towards the controller or module until it "clicks" into place.
6	Push down the locking device (<i>see page 17</i>) on the top of the new module to lock it to the controller or previously installed module.

Disassembling a Module from a Controller

Introduction

This section describes how to disassemble a module from a controller.



HAZARD OF ELECTRIC SHOCK, EXPLOSION OR ARC FLASH

- Disconnect all power from all equipment including connected devices prior to removing any covers or doors, or installing or removing any accessories, hardware, cables, or wires except under the specific conditions specified in the appropriate hardware guide for this equipment.
- Always use a properly rated voltage sensing device to confirm the power is off where and when indicated.
- Replace and secure all covers, accessories, hardware, cables, and wires and confirm that a proper ground connection exists before applying power to the unit.
- Use only the specified voltage when operating this equipment and any associated products.

Failure to follow these instructions will result in death or serious injury.

Disassembling a Module from a Controller

The following procedure describes how to disassemble a module from a controller.

Step	Action
1	Remove all power from the control system.
2	Dismount the assembled controller and modules from the mounting rail or panel (<i>see page 26</i>).
3	Push up the locking device from the bottom of the module to disengage it from the controller.
4	Pull apart the controller and module.

Installing and Removing the Controller with Expansions

Overview

This section describes how to install and remove the controller with its expansion modules from a DIN rail.

Installing a Controller with its Expansions on a DIN Rail

The following procedure describes how to install a controller with its expansion modules on a DIN rail:

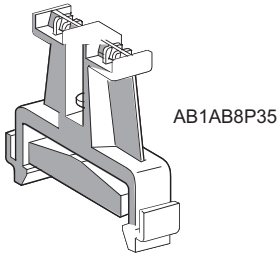
Step	Action
1	Fasten the DIN rail to a panel surface using screws.
2	Position the top groove of the controller and its expansion modules on the top edge of the DIN rail and press the assembly against the DIN rail until you hear the DIN rail clip snap into place.
3	Place 2 terminal block end clamps on both sides of the controller and expansion module assembly.  <p>NOTE: Type ABB8P35 or equivalent terminal block end clamps help minimize sideways movement and improve the shock and vibration characteristics of the controller and expansion module assembly.</p>

Removing a Controller with its Expansions from a DIN Rail

The following procedure describes how to remove a controller with its expansion modules from a DIN rail:

Step	Action
1	Insert a flat screwdriver into the slot of the DIN rail clip.
2	Pull down the DIN rail clip.
3	Pull the controller and its expansion modules from the DIN rail from the bottom.

Mounting a Module Directly on a Panel Surface

Overview

This section shows how to install your module using the Panel Mounting Kit. This section also provides mounting hole layout for all modules. Your module may differ from the module appearing in these illustrations but the procedure is still applicable.

Installing the Panel Mount Kit

The following procedure shows how to install a mounting strip.

Step	Action
1	Remove the clip-on-lock from the back side of the module by pushing the clip-on lock upwards.
2	Insert the mounting strip, with the hook entering last, into the slot where the clip-on lock was removed.
3	Slide the mounting strip into the slot until the hook enters into the recess in the module.

The following illustration shows how to attach the TWDXMT5 Panel Mount Kit to a module:

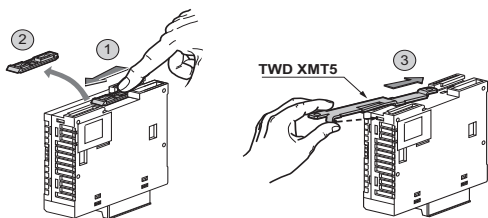

Mounting Hole Layout for Modules

The following diagram shows the mounting hole layout for all modules:

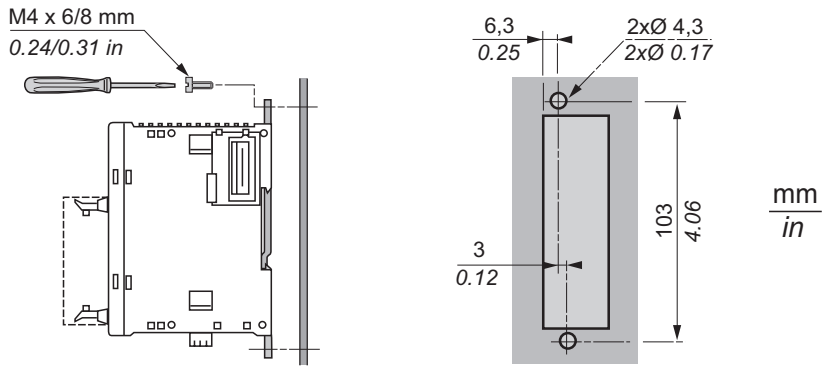

Wiring Requirements

Introduction

There are several rules that must be followed when wiring a TM2 I/O module.

For modules that have more than one terminal block or connector that is identical, any of them can be potentially inserted into any socket.

Despite the indicators on the terminal blocks, connectors and modules, it is possible to incorrectly install the terminal blocks or connectors and create incorrect wiring.

Inserting a connector into an incorrect socket could cause unintended behavior of the application and/or present a risk of bodily injury.

DANGER

ELECTRIC SHOCK OR UNINTENDED EQUIPMENT OPERATION

Connect the terminal blocks to their designated location.

Failure to follow these instructions will result in death or serious injury.

NOTE: Clearly and uniquely label each terminal block and connector with an appropriate system of identification.

Wiring Guidelines

DANGER

HAZARD OF ELECTRIC SHOCK, EXPLOSION OR ARC FLASH

- Disconnect all power from all equipment including connected devices prior to removing any covers or doors, or installing or removing any accessories, hardware, cables, or wires except under the specific conditions specified in the appropriate hardware guide for this equipment.
- Always use a properly rated voltage sensing device to confirm the power is off where and when indicated.
- Replace and secure all covers, accessories, hardware, cables, and wires and confirm that a proper ground connection exists before applying power to the unit.
- Use only the specified voltage when operating this equipment and any associated products.

Failure to follow these instructions will result in death or serious injury.







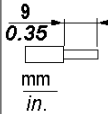

The following rules must be applied when wiring the analog I/O modules:

- I/O and communication wiring must be kept separate from the power wiring. Route these 2 types of wiring in separate cable ducting.
- Verify that the operating conditions and environment are within the specification values.
- Use proper wire sizes to meet voltage and current requirements.
- Use copper conductors only.
- Use twisted-pair, shielded cables for analog, expert and/or fast I/O.
- Use twisted-pair, shielded cables for networks and field bus (CANopen, serial, Ethernet).

⚠ WARNING
UNINTENDED EQUIPMENT OPERATION
<ul style="list-style-type: none"> • Use shielded cables for all input, output and communication types specified above. • Properly ground the cable shields as indicated in the related documentation. • Route communications and I/O cables separately from power cables. <p>Failure to follow these instructions can result in death, serious injury, or equipment damage.</p>

For more details, refer to Grounding ([see page 30](#)).

The following table shows the cable types and wire sizes for removable screw terminal block:

 <p>9 0.35 mm in.</p>							
mm ²	0,14...1,5	0,25...0,5	0,25...1,5	0,14...0,5	0,14...0,75	0,25...0,34	0,5
AWG	26...16	24...20	24...16	26...20	26...18	24...22	20

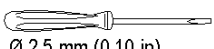
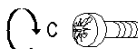
 Ø 2,5 mm (0.10 in)		N_{em}	0,23
		lb-in.	2,0

Use copper conductors only

Applying torque above the limit specified may damage the terminal screw or threads.

NOTICE
INOPERABLE EQUIPMENT
Do not tighten screw terminals beyond the specified maximum torque (Nm / lb-in.).
Failure to follow these instructions can result in equipment damage.

Grounding

Presentation

Electromagnetic radiation may interfere with control communications and/or input/output signals to the control system.

Use shielded, properly grounded cables for all analog and high-speed inputs or outputs and communication connections. If you do not use shielded cable for these connections, electromagnetic interference can cause signal degradation. Degraded signals can cause the controller or attached modules and equipment to perform in an unintended manner.

WARNING

UNINTENDED EQUIPMENT OPERATION

- Use shielded cables for all fast I/O, analog I/O and communication signals.
- Ground cable shields for all analog I/O, fast I/O and communication signals at a single point¹.
- Route communication and I/O cables separately from power cables.

Failure to follow these instructions can result in death, serious injury, or equipment damage.

¹Multipoint grounding is permissible if connections are made to an equipotential ground plane dimensioned to help avoid cable shield damage in the event of power system short-circuit currents.

WARNING

INACCURATE ANALOG CONVERSIONS

Make sure that an appropriate, braided ground cable is attached to the ground terminal of the module and securely attached to the protective ground connection of your system.

Failure to follow these instructions can result in death, serious injury, or equipment damage.

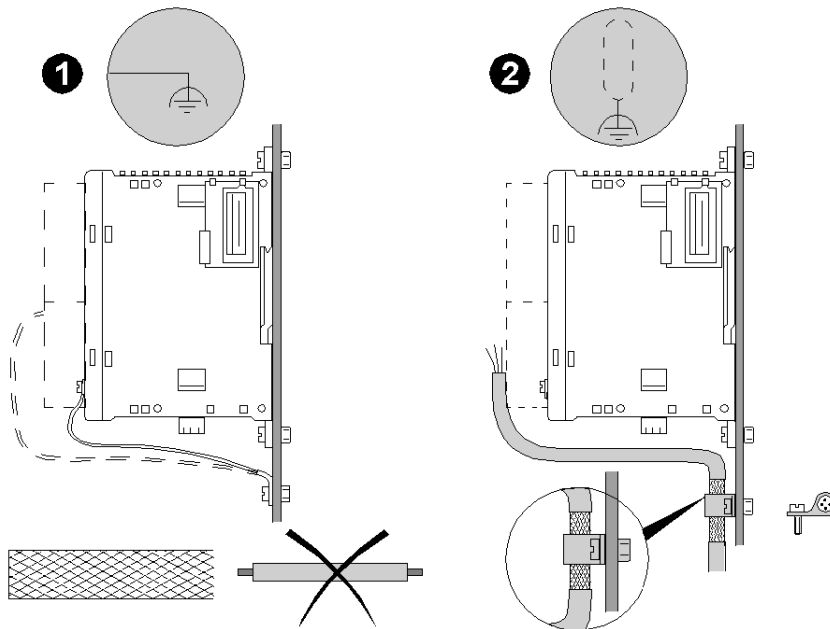

N°	Signification	Description
1	Grounding of the module	Connect the module to the functional ground (FE) terminal with the braided cable supplied with the module.
2	Grounding of the sensor	<p>Attach and ground the shielding of cables as close as possible to the controller base:</p> <ul style="list-style-type: none"> ● Strip the shielding ● Attach the cable to the metal support by attaching the clamp to the stripped part of the shielding. <p>The shielding must be clamped tightly enough to the metal support to permit good contact.</p>

Grounding Bar TM2XMTGB

The figure below shows how to connect the grounding bar TM2XMTGB:

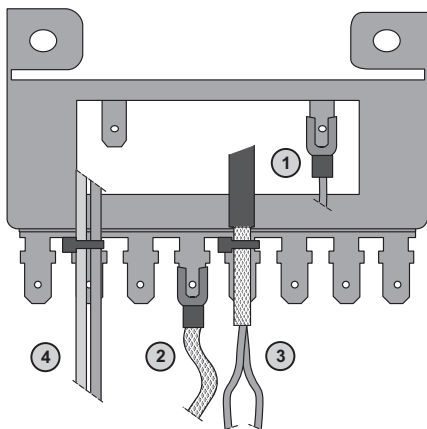

- 1 Controller functional grounding
- 2 Modules functional grounding
- 3 Analog fast I/O cable shielding
- 4 Cable attachment

NOTE: The TM2XMTGB Grounding Bar is available for use with TM2 I/O modules.

⚠ WARNING

ACCIDENTAL DISCONNECTION FROM PROTECTIVE GROUND (PE)

- Do not use the TM2XMTGB grounding plate to provide a protective ground (PE).
- Use the TM2XMTGB grounding plate only to provide a functional ground (FE).

Failure to follow these instructions can result in death, serious injury, or equipment damage.

Chapter 2

Environmental Characteristics of TM2 I/O Modules

Environmental Characteristics of TM2 I/O Modules

TM2 I/O Modules Environmental Characteristics

All the TM2 Analog I/O modules are electrically isolated with the use of a photocoupler between the internal electronic circuit and the analog channels.

WARNING

UNINTENDED EQUIPMENT OPERATION

Do not exceed any of the rated values specified in the environmental and electrical characteristics tables.

Failure to follow these instructions can result in death, serious injury, or equipment damage.

TM2 I/O Modules Climatic and Mechanical Characteristics		
Temperature	Operation	0 ... 55°C (32 ... 31°F)
	Storage	- 25 ... 70°C (-13 ... 158°F)
Relative humidity		30 ... 95 % (non-condensing)
Degree of pollution		2 (IEC 60664)
Degree of protection		IP 20 (IEC 60529)
Corrosion immunity		Free from corrosive gases
Altitude	Operation	0 ... 2000 m (0 ... 6,560 ft)
	Storage	0 ... 3000 m (0 ... 9,840 ft)
Vibration resistance	Mounted on a mounting rail	3.5 mm fixed amplitude from 5 ... 8.5 Hz 9.8 m/s ² (1 g _n) fixed acceleration from 8.5 ... 150 Hz
	Plate or panel mounted	10 mm fixed amplitude from 5 ... 8.7 Hz 29.4 m/s ² (3 g _n) fixed acceleration from 8.5 ... 150 Hz
Mechanical shock resistance		147 m/s ² (15g) for 11 ms duration

TM2 I/O Modules EMC Characteristics	
Electrostatic discharge IEC/EN 61000-4-2	8 kV (air discharge) 6 kV (contact discharge)
Radiated electromagnetic field IEC/EN 61000-4-3	10 V/m (80 MHz... 2 GHz) 1 V/m (2... 2.7 GHz)
Magnetic field IEC/EN 61000-4-8	30 A/m
Fast Transient Burst IEC/EN 61000-4-4	Power supply: 2 kV I/O: 1 kV shielded cable: 1 kV Repetition rate: 5 and 100 kHz
Induced electromagnetic field IEC/EN 61000-4-6	10 V _{eff} (0.15...80 MHz)
Surge immunity IEC/EN 61000-4-5 24 Vdc circuit:	1 kV in Common mode 0.5 kV in differential mode
Conducted emissions	Class A: according to EN 55022/55011 150 kHz...500 kHz quasi peak 79 dB μ V 500 kHz...30 MHz quasi peak 73 dB μ V
Radiated emissions	Class A: according to EN 55022/55011 d= 10 m (32.81 ft.) 30 MHz...230 MHz quasi peak 40 dB μ V Class A: according to EN 55022/55011 d= 10 m (32.81 ft.) 230 MHz...2 GHz quasi peak 47 dB μ V

Chapter 3

TM2AMI2HT Analog Input Module

Overview

This chapter describes the **TM2AMI2HT** module, its characteristics and its connection to the different sensors.

What Is in This Chapter?

This chapter contains the following topics:

Topic	Page
Presentation of the TM2AMI2HT Module	36
Characteristics of the TM2AMI2HT Module	37
Connecting the TM2AMI2HT Module	41

Presentation of the TM2AMI2HT Module

TM2AMI2HT Main Characteristics

Number of input channels	2	
Signal type	Voltage	Current
Input range	0...10 Vdc (nondifferential)	4...20 mA (nondifferential)
Resolution	12 bits (4096 points)	
Connection type	Removable screw terminal block	

Characteristics of the TM2AMI2HT Module

Introduction

This section provides a description of the electrical and the input characteristics of the **TM2AMI2HT** module.

DANGER

FIRE HAZARD

- Use only the correct wire sizes for the current capacity of the I/O channels and power supplies.
- For relay output (2 A) wiring, use conductors of at least 0.5 mm² (AWG 20) with a temperature rating of at least 80 °C (176 °F).
- For common conductors of relay output wiring (7 A), or relay output wiring greater than 2 A, use conductors of at least 1.0 mm² (AWG 16) with a temperature rating of at least 80 °C (176 °F).

Failure to follow these instructions will result in death or serious injury.

WARNING

UNINTENDED EQUIPMENT OPERATION

Do not exceed any of the rated values specified in the environmental and electrical characteristics tables.

Failure to follow these instructions can result in death, serious injury, or equipment damage.

Dimensions

The following diagrams shows the dimensions for the TM2AMI2HT analog input module.

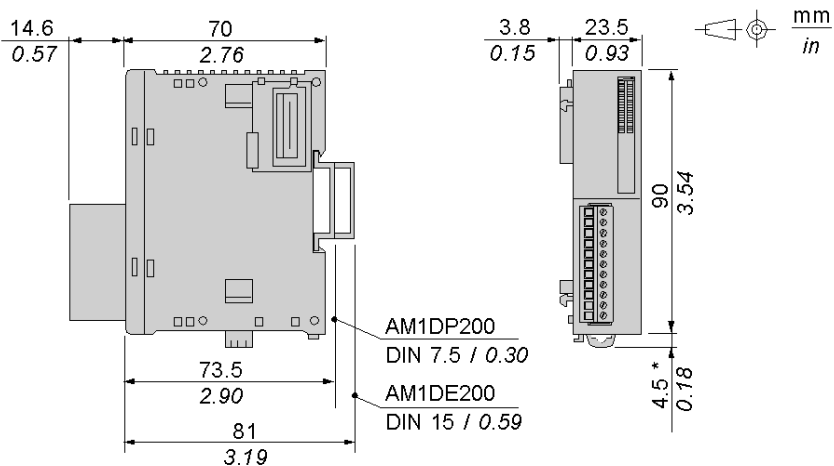

NOTE: * 8.5 mm (0.33 in) when the clip-on lock is pulled out.

TM2AMI2HT General characteristics

Rated power supply voltage	24 Vdc
Power supply range	20.4...28.8 Vdc
Connector insertion/removal durability	100 times minimum
Internal 5 Vdc current draw	50 mA
Internal 24 Vdc current draw	0 mA
External 24 Vdc current draw	40 mA
Weight	85 g (3 oz)

TM2AMI2HT Input characteristics

Characteristic	Voltage input	Current input
Input range	0...10 Vdc	4...20 mA
Input impedance	1 M Ω min.	10 Ω
Sample duration time	10 ms max.	
Total input system transfer time	2 x 10 ms + 1 scan time ¹	
Input type	Nondifferential	Nondifferential
Operating mode	Self-scan	
Conversion mode	$\Sigma\Delta$ type ADC	
Input tolerance - maximum deviation at ambient 25°C (77°F)	± 0.2 % of full scale	
Input tolerance - temperature drift	± 0.006 % of full scale/°C	
Input deviation - repeatable after stabilization time	± 0.5 % of full scale	
Input tolerance - nonlinear	± 0.2 % of full scale	
Input tolerance - maximum deviation	± 1 % of full scale	
Resolution	12 bits(4096 increments)	
Input value of LSB	2.5 mV	4.8 μ A
Data type in application program	0 to 4095 (12 bit data) Scalable to -32768 to 32767 ²	
Input data out of range detection	Yes ³	
Noise resistance - maximum temporary deviation during perturbations	± 3 % maximum when EMC perturbation is applied to the power and I/O wiring	
Noise resistance - cable	Twisted-pair shielded cable is necessary	
Noise resistance - crosstalk	2 LSB maximum	
Isolation between external power supply and inputs	500 Vac	

Characteristic	Voltage input	Current input
Isolation between inputs and logic circuits	Photocoupler between input and internal circuit (2500 Vac)	
Maximum continuous allowed overload (no damage)	13 Vdc	40 mA
Selection of analog input signal type	Using programming software	
Calibration or verification to maintain rated accuracy	Approximately 10 years	

NOTE:

1. Total input system transfer time = sample repetition x active channel number + 1 scan time.
2. The 12-bit data (0 to 4095) processed in the Analog I/O module can be linear-converted to a value between -32768 and 32767. The optional scaling designation and analog I/O data minimum and maximum values can be selected using data registers allocated to analog I/O modules.
3. When an input error is detected, a corresponding error code is stored to a data register allocated to analog I/O operating status.

Connecting the TM2AMI2HT Module

Wiring Requirements

See Wiring Requirements (*see page 28*).

TM2AMI2HT Wiring Diagram

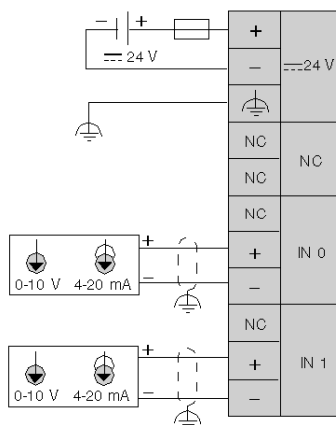

Use the braid supplied with the module to connect the functional ground

Connect an appropriate fuse for the applied voltage and current draw, at the position shown in the diagram.

NOTE: The (-) poles of inputs IN0 and IN1 are connected internally.

Use shielded, properly grounded cables for all analog and high-speed inputs or outputs and communication connections. If you do not use shielded cable for these connections, electromagnetic interference can cause signal degradation. Degraded signals can cause the controller or attached modules and equipment to perform in an unintended manner.

⚠ WARNING

UNINTENDED EQUIPMENT OPERATION

- Use shielded cables for all fast I/O, analog I/O and communication signals.
- Ground cable shields for all analog I/O, fast I/O and communication signals at a single point¹.
- Route communication and I/O cables separately from power cables.

Failure to follow these instructions can result in death, serious injury, or equipment damage.

¹Multipoint grounding is permissible if connections are made to an equipotential ground plane dimensioned to help avoid cable shield damage in the event of power system short-circuit currents.

 **WARNING**

UNINTENDED EQUIPMENT OPERATION

Do not connect wires to unused terminals and/or terminals indicated as “No Connection (N.C.)”.

Failure to follow these instructions can result in death, serious injury, or equipment damage.

Chapter 4

TM2AMI2LT Analog Input Module

Overview

This chapter describes the **TM2AMI2LT** module, its characteristics and its connection to the different sensors.

What Is in This Chapter?

This chapter contains the following topics:

Topic	Page
Presentation of the TM2AMI2LT Module	44
Characteristics of the TM2AMI2LT Module	45
Connecting the TM2AMI2LT Module	49

Presentation of the TM2AMI2LT Module

TM2AMI2LT Main Characteristics

Number of input channels	2
Sensor type	Thermocouple
Input type	Type K: -200...760°C (-328...1400°F) Type J: -270...1370°C (-454...2498°F) Type T: -270...400°C (-270...752°F)
Resolution	12 bits (4096 points)
Connection type	Removable screw terminal block

Characteristics of the TM2AMI2LT Module

Introduction

This section provides a description of the electrical and the input characteristics of the **TM2AMI2LT** module.

DANGER

FIRE HAZARD

- Use only the correct wire sizes for the current capacity of the I/O channels and power supplies.
- For relay output (2 A) wiring, use conductors of at least 0.5 mm² (AWG 20) with a temperature rating of at least 80 °C (176 °F).
- For common conductors of relay output wiring (7 A), or relay output wiring greater than 2 A, use conductors of at least 1.0 mm² (AWG 16) with a temperature rating of at least 80 °C (176 °F).

Failure to follow these instructions will result in death or serious injury.

WARNING

UNINTENDED EQUIPMENT OPERATION

Do not exceed any of the rated values specified in the environmental and electrical characteristics tables.

Failure to follow these instructions can result in death, serious injury, or equipment damage.

Dimensions

The following diagrams show the dimensions for the TM2AMI2LT analog input module.

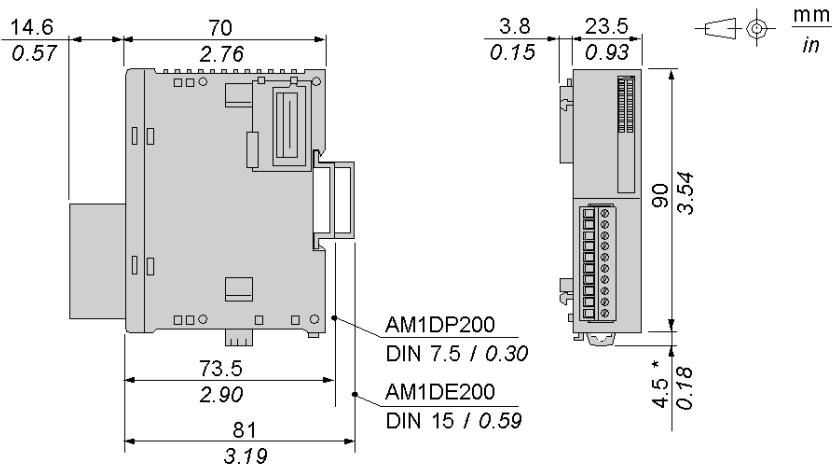

NOTE: * 8.5 mm (0.33 in) when the clip-on lock is pulled out.

TM2AMI2LT General Characteristics

Rated power supply voltage	24 Vdc
Power supply range	20.4...28.8 Vdc
Connector insertion/removal durability	100 times minimum
Internal 5 Vdc current draw	60 mA
Internal 24 Vdc current draw	0 mA
External 24 Vdc current draw	21 mA (inrush, 30 mA)
Weight	85 g (3 oz)

TM2AMI2LT Input Characteristics

Input range	Type K: -270...+1370 °C (-454...+2498 °F) Type J: -200...+760 °C (-328...+1400 °F) Type T: -270...+400 °C (-454...+752 °F)
Input impedance	1 MΩ min.
Sample duration time	200 ms
Total input system transfer time	400 ms + 1 scan time
Input type	Differential input
Operating mode	Self-scan
Conversion mode	ΣΔ ADC 16 bits
Maximum overload on input channel	±7.5 Vdc
Input tolerance - maximum deviation at 25°C (77°F)	0.2 % + temperature correction total error K, J, T: ±5 °C
Input tolerance - temperature drift	±0.006 % of full scale/°C
Input tolerance - repeatable after stabilization time	±0.5 % of full scale
Input tolerance - nonlinear	±0.2 % of full scale
Input tolerance- maximum deviation	±1 % of full scale
Resolution	Type T: 13 bits Type J, K: 14 bits
Input value of LSB	0.1 °C (0.18 °F)
Data type in application program	0 to 4095 Scalable to -32768 to 32767
Temperature Setting	Celsius (factory default setting) Fahrenheit (user-configurable)
Input data out of range detection	Yes ¹
Noise resistance - maximum temporary deviation during perturbations	±1 % maximum
Noise resistance - cable	Twisted-pair shielded cable is necessary
Noise resistance - crosstalk	2 LSB maximum
Isolation between inputs	None
Isolation between inputs and logic circuits	Photocoupler between input and internal circuit (2500 Vac)
Isolation between external power supply and inputs	500 Vac
Selection of analog input signal type	Using SoMachine
Calibration or verification to maintain rated accuracy	Approximately 10 years

50/60 Hz rejection and filtering	50/60 Hz: 120 dB rejection typ. (common mode) 60 dB rejection typ. (differential mode) Numeric filtering function by firmware
Temperature drift	30 ppm/°C
Cold junction compensation	Internal temperature sensor
Default input value in case of sensor disconnection	Ambient temperature of the module

NOTE:

1. Total input system transfer time = sample repetition x active channel number + 1 scan time.

Connecting the TM2AMI2LT Module

Wiring Requirements

See Wiring Requirements (*see page 28*).

TM2AMI2LT Wiring Diagram

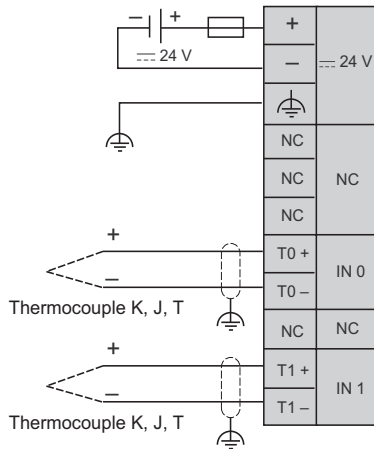

(1) Thermocouple K, J, T

Use the braid supplied with the module to connect the functional ground.

Connect an appropriate fuse for the applied voltage and current draw, at the position shown in the diagram.

Use shielded, properly grounded cables for all analog and high-speed inputs or outputs and communication connections. If you do not use shielded cable for these connections, electromagnetic interference can cause signal degradation. Degraded signals can cause the controller or attached modules and equipment to perform in an unintended manner.

⚠ WARNING

UNINTENDED EQUIPMENT OPERATION

- Use shielded cables for all fast I/O, analog I/O and communication signals.
- Ground cable shields for all analog I/O, fast I/O and communication signals at a single point¹.
- Route communication and I/O cables separately from power cables.

Failure to follow these instructions can result in death, serious injury, or equipment damage.

¹Multipoint grounding is permissible if connections are made to an equipotential ground plane dimensioned to help avoid cable shield damage in the event of power system short-circuit currents.

 WARNING

UNINTENDED EQUIPMENT OPERATION

Do not connect wires to unused terminals and/or terminals indicated as “No Connection (N.C.)”.

Failure to follow these instructions can result in death, serious injury, or equipment damage.

Chapter 5

TM2AMI4LT Analog Input Module

Overview

This chapter describes the **TM2AMI4LT** module, its characteristics and its connection to the different sensors.

What Is in This Chapter?

This chapter contains the following topics:

Topic	Page
Presentation of the TM2AMI4LT Module	52
Characteristics of the TM2AMI4LT Module	53
Connecting the TM2AMI4LT Module	57

Presentation of the TM2AMI4LT Module

TM2AMI4LT Main Characteristics

Number of input channels	4		
Signal/sensor type	Voltage	Current	Temperature
Input type	0...10 Vdc (non differential)	0....20 mA (non differential)	PT100/1000 Ni100/1000
Resolution	12 bits (4096 points)		
Connection type	Removable screw terminal block		

Characteristics of the TM2AMI4LT Module

Introduction

This section provides a description of the electrical and the input characteristics of the **TM2AMI4LT** module.

DANGER

FIRE HAZARD

- Use only the correct wire sizes for the current capacity of the I/O channels and power supplies.
- For relay output (2 A) wiring, use conductors of at least 0.5 mm² (AWG 20) with a temperature rating of at least 80 °C (176 °F).
- For common conductors of relay output wiring (7 A), or relay output wiring greater than 2 A, use conductors of at least 1.0 mm² (AWG 16) with a temperature rating of at least 80 °C (176 °F).

Failure to follow these instructions will result in death or serious injury.

WARNING

UNINTENDED EQUIPMENT OPERATION

Do not exceed any of the rated values specified in the environmental and electrical characteristics tables.

Failure to follow these instructions can result in death, serious injury, or equipment damage.

Dimensions

The following diagrams show the dimensions for the TM2 AMI4LT analog input module.

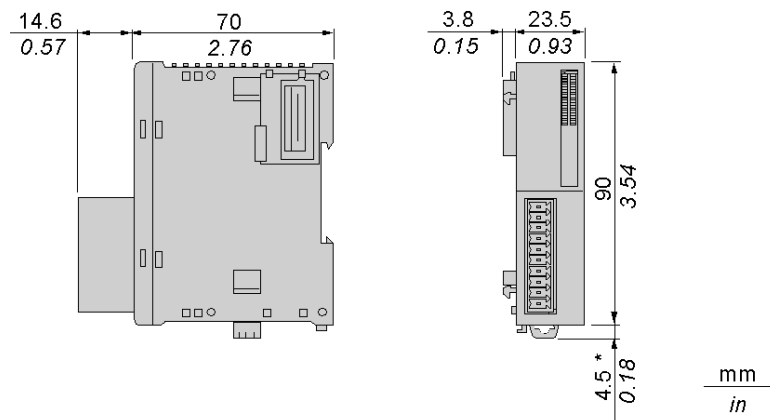

NOTE: * 8.5 mm (0.33 in) when the clip-on lock is pulled out.

TM2AMI4LT General Characteristics

Rated power supply voltage	24 Vdc
Power supply range	19.2...30 Vdc including ripple
Connector insertion/removal durability	100 times minimum
Internal 5 Vdc current draw	50 mA
Internal 24 Vdc current draw	0 mA
External 24 Vdc current draw	60 mA
Weight	85 g (3 oz)

TM2AMI4LT Input Characteristics

Characteristic	Voltage input	Current input	Temperature probe input
Input range	0...10 Vdc	0...20 mA	(RTD) Pt 100, Pt 1000, Ni 100, Ni 1000 3-wire type Pt sensor -200...600 °C (-328...1112 °F) Ni sensor -50...150 °C (-58...302 °F)
Input impedance	> 10 kΩ	< 250 Ω	> 10 kΩ
Sample duration time	160 ms		
Total input system transfer time	4x160 ms + 1 scan time		8x160 ms + 1 scan time
Input type	Nondifferential		
Operating mode	Self-scan		
Conversion mode	ΣΔ type ADC		
Input tolerance - maximum deviation at 25°C (77°F)	±0.2 % of full scale ± 0.4 % temperature probe input		
Input tolerance - temperature drift	±0.005 % of full scale/°C		
Input tolerance - repeatable after stabilization time	± 0.1% of full scale		
Input tolerance - nonlinear	±0.02 % of full scale		
Input tolerance - maximum deviation	±0.5 % of full scale		
Resolution	12 bits (4096 increments)		
Input value of LSB	2.5 mV	4.8 μA	K: 0.15 °C (K: 0.27 °F)
Data type in application program	0 to 4095 Scalable to -32768 to 32767 ²		
Input data out of range detection	Yes ³		
Noise resistance - cable	Twisted-pair shielded cable is necessary for improved noise immunity		
Noise resistance - external crosstalk	1 LSB maximum		
Isolation between inputs, external power supply and internal logic circuits	2500 Vac by photocoupler		
Isolation between inputs	None		

Characteristic	Voltage input	Current input	Temperature probe input
Type of protection	Photocoupler between input and internal circuit (1500 Vdc isolation)		
Maximum continuous allowed overload (no damage)	13 Vdc	40 mA	-
Selection of analog input signal type	Using programming software NOTE: All inputs have the same voltage/current configuration or temperature. For temperature, it is possible to configure each channel independently of the type of probe.		
Calibration or verification to maintain rated accuracy	Approximately 10 years		
Default input value in case of temperature sensor disconnectio	Upper limit		

NOTE:

1. Total input system transfer time = sample repetition x 2 + 1 scan time.
2. The 12-bit data (0 to 4095) processed in the Analog I/O module can be linear-converted to a value between -32768 and 32767. The optional range designation and analog I/O data minimum and maximum values can be selected using data registers allocated to analog I/O modules.
3. When an input error is detected, a corresponding error code is stored to a data register allocated to analog I/O operating status.

Connecting the TM2AMI4LT Module

Wiring Requirements

See Wiring Requirements ([see page 28](#)).

TM2AMI4LT Wiring Diagram

This wiring diagram is for inputs configured for measuring temperature.

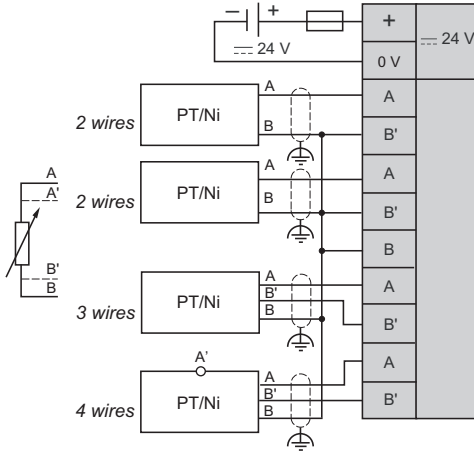

This wiring diagram is for inputs configured for measuring voltage/current.

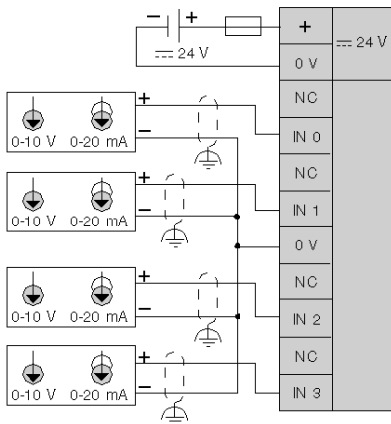

Connect an appropriate fuse for the applied voltage and current draw, at the position shown in the diagram.

Use shielded, properly grounded cables for all analog and high-speed inputs or outputs and communication connections. If you do not use shielded cable for these connections, electromagnetic interference can cause signal degradation. Degraded signals can cause the controller or attached modules and equipment to perform in an unintended manner.

 WARNING

UNINTENDED EQUIPMENT OPERATION

- Use shielded cables for all fast I/O, analog I/O and communication signals.
- Ground cable shields for all analog I/O, fast I/O and communication signals at a single point¹.
- Route communication and I/O cables separately from power cables.

Failure to follow these instructions can result in death, serious injury, or equipment damage.

¹Multipoint grounding is permissible if connections are made to an equipotential ground plane dimensioned to help avoid cable shield damage in the event of power system short-circuit currents.

 WARNING

UNINTENDED EQUIPMENT OPERATION

Do not connect wires to unused terminals and/or terminals indicated as “No Connection (N.C.)”.

Failure to follow these instructions can result in death, serious injury, or equipment damage.

NOTE: To help avoid interference of the analog signals, the power supply of the module must be turned on or off at the same time than the base controller power supply.

 WARNING

UNINTENDED EQUIPMENT OPERATION

Turn the power supplies for the module and the associated controller on and off at the same time.

Failure to follow these instructions can result in death, serious injury, or equipment damage.

Chapter 6

TM2AMI8HT Analog Input Module

Overview

This chapter describes the **TM2AMI8HT** module, its characteristics and its connection to the different sensors.

What Is in This Chapter?

This chapter contains the following topics:

Topic	Page
Presentation of the TM2AMI8HT Module	60
Characteristics of the TM2AMI8HT Module	61
Connecting the TM2AMI8HT Module	64

Presentation of the TM2AMI8HT Module

TM2AMI8HT Main Characteristics

Number of input channels	8	
Signal type	Voltage	Current
Input range	0...10 Vdc (non differential)	0...20 mA (non differential)
Resolution	10 bits (1024 points)	
Connection type	Removable screw terminal block	

Characteristics of the TM2AMI8HT Module

Introduction

This section provides a description of the electrical and the input characteristics of the **TM2AMI8HT** module.

DANGER

FIRE HAZARD

- Use only the correct wire sizes for the current capacity of the I/O channels and power supplies.
- For relay output (2 A) wiring, use conductors of at least 0.5 mm² (AWG 20) with a temperature rating of at least 80 °C (176 °F).
- For common conductors of relay output wiring (7 A), or relay output wiring greater than 2 A, use conductors of at least 1.0 mm² (AWG 16) with a temperature rating of at least 80 °C (176 °F).

Failure to follow these instructions will result in death or serious injury.

WARNING

UNINTENDED EQUIPMENT OPERATION

Do not exceed any of the rated values specified in the environmental and electrical characteristics tables.

Failure to follow these instructions can result in death, serious injury, or equipment damage.

Dimensions

The following diagrams show the dimensions for the TM2AMI8HT analog input module.

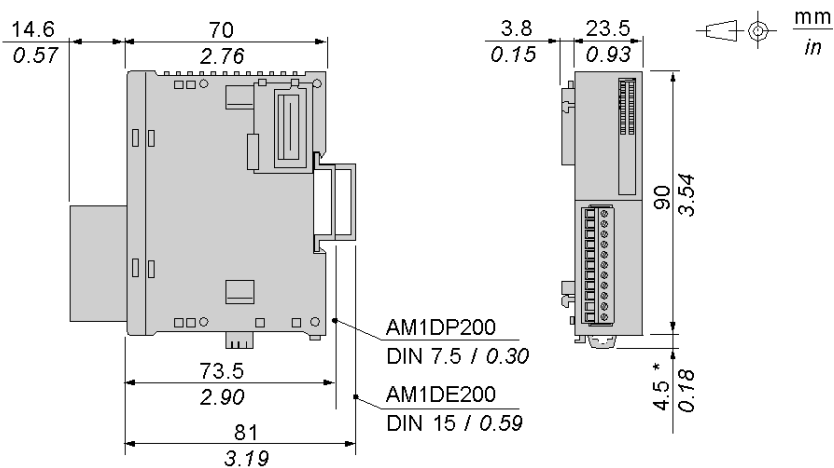

NOTE: * 8.5 mm (0.33 in) when the clip-on lock is pulled out.

TM2AMI8HT General Characteristics

Rated power supply voltage	24 Vdc
Power supply range	19.2...30 Vdc including ripple
Connector insertion/removal durability	100 times minimum
Internal 5 Vdc current draw	50 mA
Internal 24 Vdc current draw	0 mA
External 24 Vdc current draw	45 mA
Weight	85 g (3 oz)

TM2AMI8HT Input Characteristics

Characteristic	Voltage input	Current input
Input range	0...10 Vdc	0...20 mA DC
Input impedance	10 KΩ min.	< 250 Ω
Sample duration time	160 ms	
Total input system transfer time	8 x 160 ms + 1 scan time	
Input type	Nondifferential	

Characteristic	Voltage input	Current input
Operating mode	Self-scan	
Conversion mode	$\Sigma\Delta$ type ADC	
Input error - maximum error at 25°C (77°F)	± 0.2 % of full scale	
Input tolerance - temperature drift	± 0.5 % of full scale/°C	
Input tolerance - repeatable after stabilization time	± 0.4 % of full scale	
Input tolerance - nonlinear	± 0.002 % of full scale	
Input tolerance - maximum deviation	1 % of full scale	
Resolution	10 bits (1024 increments)	
Input value of LSB	9.7 mV	19.5 μ A
Data type in application program	0 to 1023 (10 bit) Scalable to -32768 to 32767	
Input data out of range detection	Yes ¹	
Noise resistance - maximum temporary deviation during perturbations	± 1 % of full scale	
Noise resistance - cable	Twisted-pair shielded cable is necessary	
Noise resistance - crosstalk	1 LSB maximum	
Isolation between inputs and power supply	None	
Isolation between inputs	None	
Isolation between power supply, inputs and internal logic circuits	2500 Vac by photocoupler	
Maximum continuous allowed overload (no damage)	13 Vdc	40 mA
Calibration or verification to maintain rated accuracy	Approximately 10 years	

NOTE:

1. Total input system transfer time = sample repetition x 2 + 1 scan time.

Connecting the TM2AMI8HT Module

Wiring Requirements

See Wiring Requirements (*see page 28*).

TM2AMI8HT Wiring Diagram

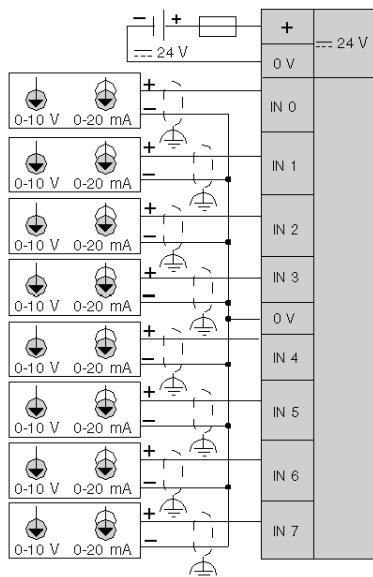

Connect an appropriate fuse for the applied voltage and current draw, at the position shown in the diagram.

Use shielded, properly grounded cables for all analog and high-speed inputs or outputs and communication connections. If you do not use shielded cable for these connections, electromagnetic interference can cause signal degradation. Degraded signals can cause the controller or attached modules and equipment to perform in an unintended manner.

⚠ WARNING**UNINTENDED EQUIPMENT OPERATION**

- Use shielded cables for all fast I/O, analog I/O and communication signals.
- Ground cable shields for all analog I/O, fast I/O and communication signals at a single point¹.
- Route communication and I/O cables separately from power cables.

Failure to follow these instructions can result in death, serious injury, or equipment damage.

¹Multipoint grounding is permissible if connections are made to an equipotential ground plane dimensioned to help avoid cable shield damage in the event of power system short-circuit currents.

⚠ WARNING**UNINTENDED EQUIPMENT OPERATION**

Do not connect wires to unused terminals and/or terminals indicated as “No Connection (N.C.)”.

Failure to follow these instructions can result in death, serious injury, or equipment damage.

NOTE: To help avoid interference of the analog signals, the power supply of the module must be turned on or off at the same time than the base controller power supply.

⚠ WARNING**UNINTENDED EQUIPMENT OPERATION**

Turn the power supplies for the module and the associated controller on and off at the same time.

Failure to follow these instructions can result in death, serious injury, or equipment damage.

Chapter 7

TM2ARI8HT Analog Input Module

Overview

This chapter describes the **TM2ARI8HT** module, its characteristics and its connection to the different sensors.

What Is in This Chapter?

This chapter contains the following topics:

Topic	Page
Presentation of the TM2ARI8HT Module	68
Characteristics of the TM2ARI8HT Module	69
Connecting the TM2ARI8HT Module	72

Presentation of the TM2ARI8HT Module

TM2ARI8HT Main Characteristics

Number of input channels	8
Signal type	Temperature
Input range	NTC/PTC, $100 \Omega < R < 10 \text{ k}\Omega$
Resolution	10 bits (1024 points)
Connection type	Removable screw terminal block

Characteristics of the TM2ARI8HT Module

Introduction

This section provides a description of the electrical and the input characteristics of the **TM2ARI8HT** module.

DANGER

FIRE HAZARD

- Use only the correct wire sizes for the current capacity of the I/O channels and power supplies.
- For relay output (2 A) wiring, use conductors of at least 0.5 mm² (AWG 20) with a temperature rating of at least 80 °C (176 °F).
- For common conductors of relay output wiring (7 A), or relay output wiring greater than 2 A, use conductors of at least 1.0 mm² (AWG 16) with a temperature rating of at least 80 °C (176 °F).

Failure to follow these instructions will result in death or serious injury.

WARNING

UNINTENDED EQUIPMENT OPERATION

Do not exceed any of the rated values specified in the environmental and electrical characteristics tables.

Failure to follow these instructions can result in death, serious injury, or equipment damage.

Dimensions

The following diagrams show the dimensions for the TM2ARI8HT analog input module.

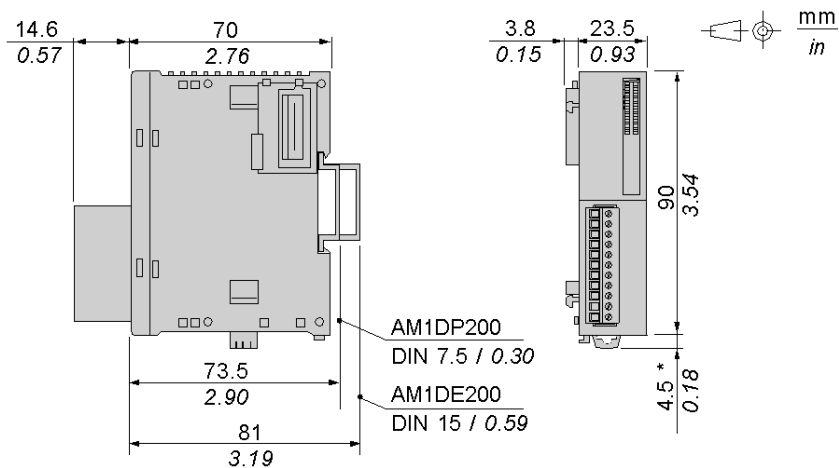

NOTE: * 8.5 mm (0.33 in) when the clip-on lock is pulled out.

TM2ARI8HT General Characteristics

Rated power supply voltage	24 Vdc
Power supply range	19.2...30 Vdc including ripple
Connector insertion/removal durability	100 times minimum
Internal 5 Vdc current draw	50 mA
Internal 24 Vdc current draw	0 mA
External 24 Vdc current draw	45 mA
Weight	85 g (3 oz)

TM2ARI8HT Input Characteristics

Input range	NTC or PTC thermistor Resistance range: 100 Ω ...10 k Ω
Input impedance	1 M Ω min.
Sample duration time	160 ms
Total input system transfer time	8x160 ms + 1 scan time
Input type	Nondifferential
Operating mode	Self-scan
Conversion mode	$\Sigma\Delta$ type ADC
Input tolerance - maximum deviation at 25°C (77°F)	± 0.2 % of full scale
Input tolerance - temperature drift	± 0.01 % of full scale/ $^{\circ}$ C
Input tolerance - repeatable after stabilization time	± 0.4 % of full scale
Input tolerance - nonlinear	± 0.002 % of full scale
Input tolerance - maximum deviation	± 1 % of full scale
Resolution	10 bits (1024 increments)
Input value of LSB	Depending on the probe
Data type in application program	0 to 1023 Scalable to -32768 to 32767
Input data out of range detection	Yes ¹
Noise resistance - maximum temporary deviation during perturbations	± 1 % of full scale
Noise resistance - cable	Twisted-pair shielded cable is necessary
Noise resistance - crosstalk	1 LSB maximum
Isolation between power supply and inputs	None
Isolation between inputs	None
Isolation between power supply, inputs and internal logic circuits	Photocoupler between input and internal circuit (2500 Vac)
Calibration or verification to maintain rated accuracy	Approximately 10 years

NOTE:

1. Total input system transfer time = sample repetition x 2 + 1 scan time.

Connecting the TM2ARI8HT Module

Wiring Requirements

See Wiring Requirements (*see page 28*).

TM2ARI8HT Wiring Diagram

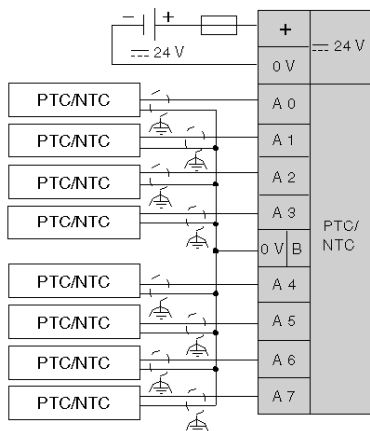

Connect an appropriate fuse for the applied voltage and current draw, at the position shown in the diagram.

Use shielded, properly grounded cables for all analog and high-speed inputs or outputs and communication connections. If you do not use shielded cable for these connections, electromagnetic interference can cause signal degradation. Degraded signals can cause the controller or attached modules and equipment to perform in an unintended manner.

⚠ WARNING

UNINTENDED EQUIPMENT OPERATION

- Use shielded cables for all fast I/O, analog I/O and communication signals.
- Ground cable shields for all analog I/O, fast I/O and communication signals at a single point¹.
- Route communication and I/O cables separately from power cables.

Failure to follow these instructions can result in death, serious injury, or equipment damage.

¹Multipoint grounding is permissible if connections are made to an equipotential ground plane dimensioned to help avoid cable shield damage in the event of power system short-circuit currents.

 **WARNING**

UNINTENDED EQUIPMENT OPERATION

Do not connect wires to unused terminals and/or terminals indicated as “No Connection (N.C.)”.

Failure to follow these instructions can result in death, serious injury, or equipment damage.

NOTE: To help avoid interference of the analog signals, the power supply of the module must be turned on or off at the same time than the base controller power supply.

 **WARNING**

UNINTENDED EQUIPMENT OPERATION

Turn the power supplies for the module and the associated controller on and off at the same time.

Failure to follow these instructions can result in death, serious injury, or equipment damage.

Chapter 8

TM2ARI8LRJ Analog Input Module

Overview

This chapter describes the **TM2ARI8LRJ** module, its characteristics and its connection to the different sensors.

What Is in This Chapter?

This chapter contains the following topics:

Topic	Page
Presentation of the TM2ARI8LRJ Module	76
Characteristics of the TM2ARI8LRJ Module	77
Connecting the TM2ARI8LRJ Module	81

Presentation of the TM2ARI8LRJ Module

TM2ARI8LRJ Main Characteristics

Number of input channels	8
Sensor type	Temperature probe
Input type	PT100 / PT1000
Resolution	12 bits (4096 points)
Connection type	8 x RJ11 connector

Characteristics of the TM2ARI8LRJ Module

Introduction

This section provides a description of the electrical and the input characteristics of the **TM2ARI8LRJ** module.

DANGER

FIRE HAZARD

- Use only the correct wire sizes for the current capacity of the I/O channels and power supplies.
- For relay output (2 A) wiring, use conductors of at least 0.5 mm² (AWG 20) with a temperature rating of at least 80 °C (176 °F).
- For common conductors of relay output wiring (7 A), or relay output wiring greater than 2 A, use conductors of at least 1.0 mm² (AWG 16) with a temperature rating of at least 80 °C (176 °F).

Failure to follow these instructions will result in death or serious injury.

WARNING

UNINTENDED EQUIPMENT OPERATION

Do not exceed any of the rated values specified in the environmental and electrical characteristics tables.

Failure to follow these instructions can result in death, serious injury, or equipment damage.

Dimensions

The following diagrams show the dimensions for the TM2ARI8LRJ analog input module.

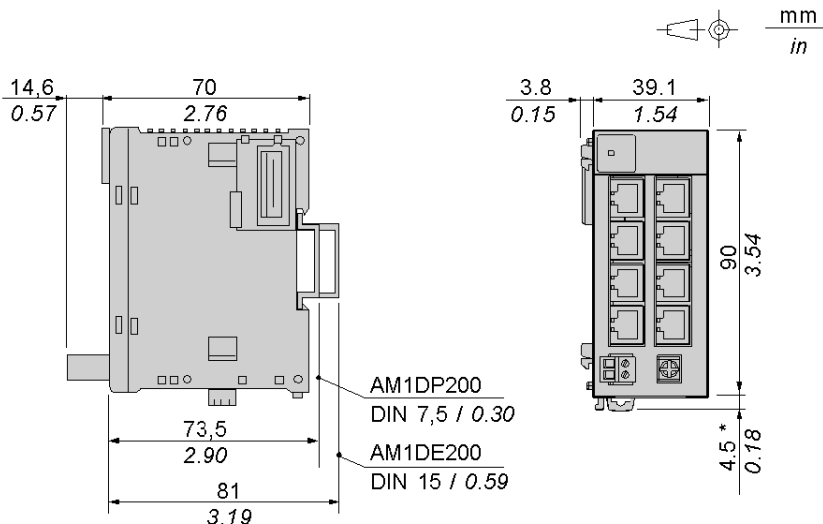

NOTE: * 8.5 mm (0.33 in) when the clip-on lock is pulled out.

TM2ARI8LRJ General Characteristics

Rated power supply voltage	24 Vdc
Power supply range	19.2...30 Vdc including ripple
RJ11 connector	50 times minimum
Power supply connector	50 times minimum
Connector insertion/removal durability	100 times minimum
Internal 5 Vdc current draw	90 mA
Internal 24 Vdc current draw	0 mA
External 24 Vdc current draw	140 mA
Weight	118 g (4.17 oz)

TM2ARI8LRJ Input Characteristics

Input range	PT1000: -50...200°C (-58...392°F) PT100: -200...600°C (-328...1112°F)
Input impedance	> 10 kΩ
Sample duration time	320 ms per channel
Total input system transfer time	4 x 320 ms + 1 scan time
Input type	Nondifferential
Operating mode	Self-scan
Conversion mode	ΣΔ type ADC
Input tolerance - maximum deviation at ambient 25°C (77°F)	PT1000: ± 0.5 °C (0.9 °F) PT100: ± 1.5 °C (2.7 °F) Range -50 °C (-58 °F) to 200 °C (392 °F): ±1 °C (33.8 °F) Range -200 °C (392 °F) to 600 °C (1112 °F): +0.1% / -0.5% full scale
Input tolerance- temperature drift	± 0.5 °C (0.9 °F)
Input deviation- repeatable after stabilization time	± 0.1°C(32.18 °F)
Resolution	12 bits (4096 increments)
Input value of LSB	PT1000: ±1°C (33.8 °F) PT100: +1°C / -4°C (33.8 °F / 24.8 °F)
Total maximum deviation	PT1000: 0.06°C (0.108 °F) PT100: 0.2°C (0.36 °F)
Data type in application program	0 to 4095 Scalable to -32768 to 32767
Input data out of range detection	Yes ⁽¹⁾
Broken wire detection	Yes ⁽¹⁾
Noise resistance - maximum temporary deviation during perturbations	±1 % of full scale
Cable resistance compensation	100 Ω max
Noise resistance - crosstalk	1 LSB maximum
Isolation between inputs	None
Isolation between inputs, power supply and internal logic circuits	Photocoupler between input and internal circuit (2500 Vac)
Isolation between inputs and external power supply	500 Vac
Dielectric strength	- 1500 Vrms between inputs and internal bus - 500 Vrms between inputs and 0V - 1500 Vrms between internal bus and 0V
Type of protection with terminal bus	Photocoupler between input and internal circuit: 1500 Vac isolation

Selection of analog input signal type	Choose PT100 and PT1000 using programming software
Default input value in case of temperature sensor disconnection	Upper limit

NOTE:

1. Total input system transfer time = sample repetition x 2 + 1 scan time.

Connecting the TM2ARI8LRJ Module

Wiring Requirements

See Wiring Requirements (*see page 28*).

TM2ARI8LRJ Wiring Diagram

The following diagram shows the connection of the module inputs.

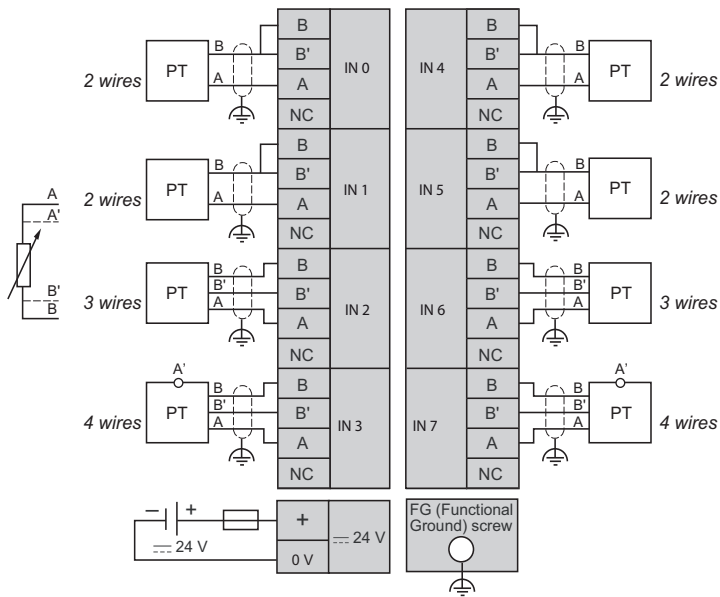
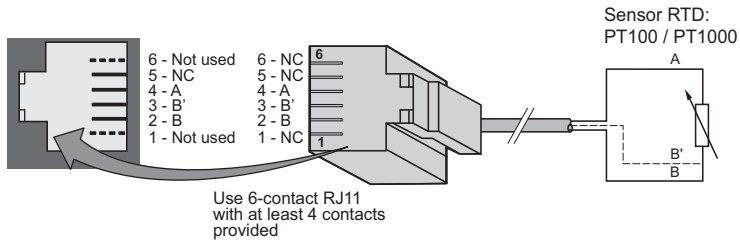

- Use RJ11 6-pin connectors with a minimum of 4 pins.
- Connect an appropriate fuse for the applied voltage and current draw, at the position shown in the diagram.
- For the functional ground screw, use a screw-driver with a diameter of 3.5 mm (0.14 in) and apply a torque of 0.5 Nm (4.4 lb-in).

Use shielded, properly grounded cables for all analog and high-speed inputs or outputs and communication connections. If you do not use shielded cable for these connections, electromagnetic interference can cause signal degradation. Degraded signals can cause the controller or attached modules and equipment to perform in an unintended manner.

⚠ WARNING

UNINTENDED EQUIPMENT OPERATION

- Use shielded cables for all fast I/O, analog I/O and communication signals.
- Ground cable shields for all analog I/O, fast I/O and communication signals at a single point¹.
- Route communication and I/O cables separately from power cables.

Failure to follow these instructions can result in death, serious injury, or equipment damage.

¹Multipoint grounding is permissible if connections are made to an equipotential ground plane dimensioned to help avoid cable shield damage in the event of power system short-circuit currents.

⚠ WARNING



UNINTENDED EQUIPMENT OPERATION

Do not connect wires to unused terminals and/or terminals indicated as “No Connection (N.C.)”.

Failure to follow these instructions can result in death, serious injury, or equipment damage.

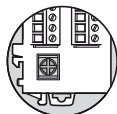
The following table shows the characteristics of the functional ground connection:



 Ø 3,5 mm (0.14 in)		N.m	0,5
		lb-in	4.4

Chapter 9

TM2ARI8LT Analog Input Module

Overview

This chapter describes the **TM2ARI8LT** module, its characteristics and its connection to the different sensors.

What Is in This Chapter?

This chapter contains the following topics:

Topic	Page
Presentation of the TM2ARI8LT Module	84
Characteristics of the TM2ARI8LT Module	85
Connecting the TM2ARI8LT Module	89

Presentation of the TM2ARI8LT Module

TM2ARI8LT Main Characteristics

Number of input channels	8
Sensor type	Temperature probe
Input type	PT100 / PT1000
Resolution	12 bits (4096 points)
Connection type	2 x Removable screw terminal block

Characteristics of the TM2ARI8LT Module

Introduction

This section provides a description of the electrical and the input characteristics of the **TM2ARI8LT** module.

DANGER

FIRE HAZARD

- Use only the correct wire sizes for the current capacity of the I/O channels and power supplies.
- For relay output (2 A) wiring, use conductors of at least 0.5 mm² (AWG 20) with a temperature rating of at least 80 °C (176 °F).
- For common conductors of relay output wiring (7 A), or relay output wiring greater than 2 A, use conductors of at least 1.0 mm² (AWG 16) with a temperature rating of at least 80 °C (176 °F).

Failure to follow these instructions will result in death or serious injury.

WARNING

UNINTENDED EQUIPMENT OPERATION

Do not exceed any of the rated values specified in the environmental and electrical characteristics tables.

Failure to follow these instructions can result in death, serious injury, or equipment damage.

Dimensions

The following diagrams show the dimensions for the TM2ARI8LT analog input module.

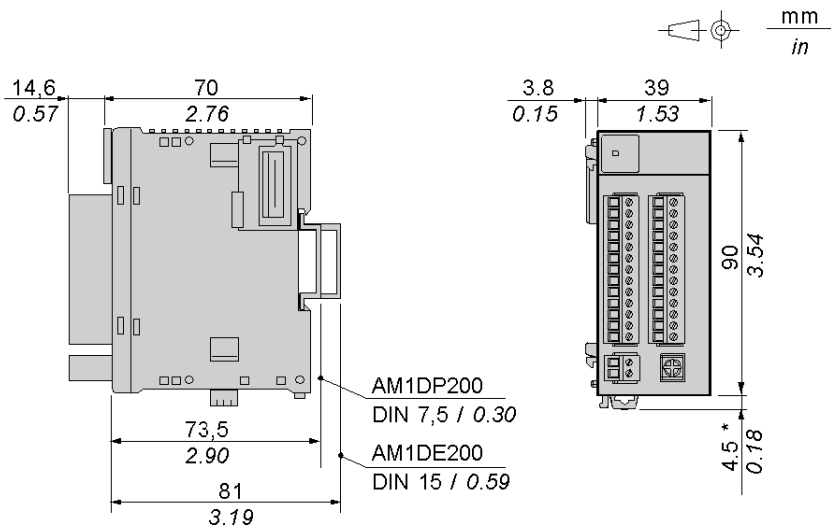

NOTE: * 8.5 mm (0.33 in) when the clip-on lock is pulled out.

TM2ARI8LT General Characteristics

Rated power supply voltage	24 Vdc
Power supply range	19.2...30 Vdc including ripple
Connector insertion/removal durability	100 times minimum
Internal 5 Vdc current draw	90 mA
Internal 24 Vdc current draw	0 mA
External 24 Vdc current draw	140 mA
Weight	147 g (8.06 oz)

TM2ARI8LT Input Characteristics

Input range	PT1000: -50...200°C (-58...392°F) PT100: -200...600°C (-328...1112°F)
Input impedance	> 10 kΩ
Sample duration time	320 ms per channel
Total input system transfer time	4 x 320 ms + 1 scan time
Input type	Differential input
Operating mode	Self-scan
Conversion mode	ΣΔ type ADC
Input tolerance - maximum deviation at ambient ± 25°C (77°F)	PT1000: ± 0.5 °C (0.9 °F) PT100: ± 1.5 °C (2.7 °F) Range -50 °C (-58 °F) to 200°C(392°F): ±1°C(±33.8 °F) Range -200 °C (392 °F) to 600 °C (1112 °F): +0.1% / -0.5% full scale
Input tolerance- temperature drift	± 0.5 °C (0.9 °F)
Input deviation - repeatable after stabilization time	±0.1 °C (±32.18 °F)
Resolution	12 bits (4096 increments)
Input value of LSB	PT1000: 0.06°C (0.108 °F) PT100: 0.2°C (0.36 °F)
Total maximum deviation	PT 1000: ±1 °C (±33.8 °F) PT100: +1 °C (33.8 °F) / -4 °C (24.8 °F)
Data type in application program	0 to 4095 Scalable to -32768 to 32767
Input data out of range detection	Yes ¹
Broken wire detection	Yes ¹
Noise resistance - maximum temporary deviation during perturbations	±1 % of full scale
Cable resistance compensation	100 Ω max
Noise resistance - crosstalk	1 LSB maximum
Isolation between inputs	None
Isolation between inputs and external power supply	500 Vac
Isolation between inputs, power supply and internal logic circuits	Photocoupler between input and internal circuit (2500 Vac)
Dielectric strength	- 1500 Vrms between inputs and internal bus - 500 Vrms between inputs and 0V - 1500 Vrms between internal bus and 0V
Type of protection with terminal bus	Photocoupler between input and internal circuit: 1500 Vac isolation

Selection of analog input signal type	Choose PT100 or PT 1000 using programming software
Default input value in case of temperature sensor disconnection	Upper limit

NOTE:

1. Total input system transfer time = sample repetition x 2 + 1 scan time.

Connecting the TM2ARI8LT Module

Wiring Requirements

See Wiring Requirements ([see page 28](#)).

TM2ARI8LT Wiring Diagram

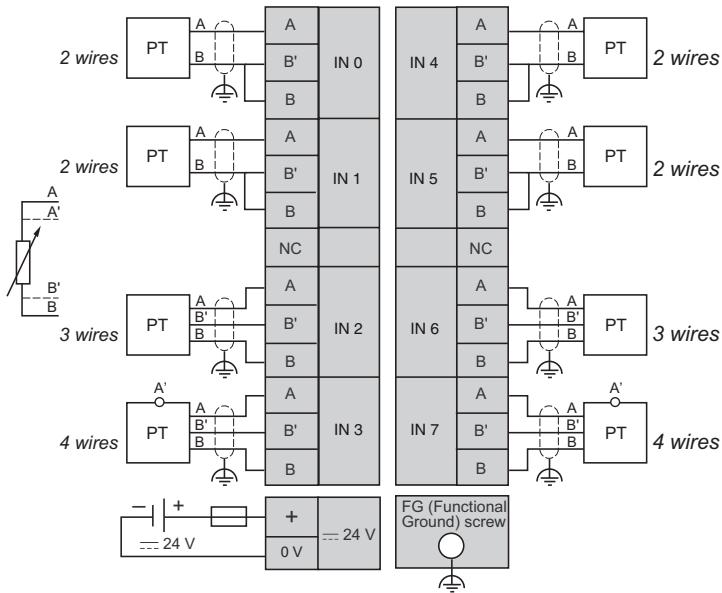

- Connect an appropriate fuse for the applied voltage and current draw, at the position shown in the diagram.
- Do not connect any wiring to unused channels.

Use shielded, properly grounded cables for all analog and high-speed inputs or outputs and communication connections. If you do not use shielded cable for these connections, electromagnetic interference can cause signal degradation. Degraded signals can cause the controller or attached modules and equipment to perform in an unintended manner.

⚠ WARNING

UNINTENDED EQUIPMENT OPERATION

- Use shielded cables for all fast I/O, analog I/O and communication signals.
- Ground cable shields for all analog I/O, fast I/O and communication signals at a single point¹.
- Route communication and I/O cables separately from power cables.

Failure to follow these instructions can result in death, serious injury, or equipment damage.

¹Multipoint grounding is permissible if connections are made to an equipotential ground plane dimensioned to help avoid cable shield damage in the event of power system short-circuit currents.

⚠ WARNING



UNINTENDED EQUIPMENT OPERATION

Do not connect wires to unused terminals and/or terminals indicated as “No Connection (N.C.)”.

Failure to follow these instructions can result in death, serious injury, or equipment damage.

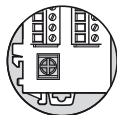
The following table shows the connection of the functional ground screw:



 Ø 3,5 mm (0.14 in)		N.m <i>lb-in</i>	0,5 4.4
---	---	---------------------	------------

Chapter 10

TM2AMO1HT Analog Output Module

Overview

This chapter describes the **TM2AMO1HT** module, its characteristics and its connection to the different sensors.

What Is in This Chapter?

This chapter contains the following topics:

Topic	Page
Presentation of the TM2AMO1HT Module	92
Characteristics of the TM2AMO1HT Module	93
Connecting the TM2AMO1HT Module	97

Presentation of the TM2AMO1HT Module

TM2AMO1HT Main Characteristics

Number of output channels	1	
Signal type	Voltage	Current
Output range	0...10 Vdc	4....20 mA
Resolution	12 bits (4096 points)	
Connection type	Removable screw terminal block	

Characteristics of the TM2AMO1HT Module

Introduction

This section provides a description of the electrical and the output characteristics of the **TM2AMO1HT** module.

DANGER

FIRE HAZARD

- Use only the correct wire sizes for the current capacity of the I/O channels and power supplies.
- For relay output (2 A) wiring, use conductors of at least 0.5 mm² (AWG 20) with a temperature rating of at least 80 °C (176 °F).
- For common conductors of relay output wiring (7 A), or relay output wiring greater than 2 A, use conductors of at least 1.0 mm² (AWG 16) with a temperature rating of at least 80 °C (176 °F).

Failure to follow these instructions will result in death or serious injury.

WARNING

UNINTENDED EQUIPMENT OPERATION

Do not exceed any of the rated values specified in the environmental and electrical characteristics tables.

Failure to follow these instructions can result in death, serious injury, or equipment damage.

Dimensions

The following diagrams show the dimensions for the TM2AMO1HT analog output module.

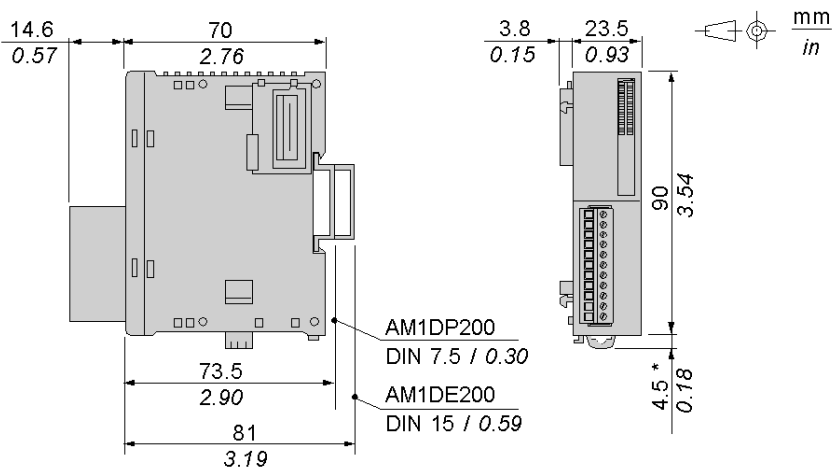

NOTE: * 8.5 mm (0.33 in) when the clip-on lock is pulled out.

TM2AMO1HT General Characteristics

Rated power supply voltage	24 Vdc
Power supply range	19.2...30 Vdc including ripple
Connector insertion/removal durability	100 times minimum
Internal 5 Vdc current draw	50 mA
Internal 24 Vdc current draw	0 mA)
External 24 Vdc current draw	40 mA
Weight	85 g (3 oz)

TM2AMO1HT Output Characteristics

Characteristic	Voltage output	Current output
Output range	0...10 Vdc	4...20 mA
Load impedance	2 kΩ minimum	300 Ω maximum
Application load type	Resistive load	
Settling time	10 ms	
Total output system transfer Time	10 ms + 1 scan time	
Output tolerance - maximum deviation at 25°C (77°F)	±0.2% of full scale	
Output tolerance - temperature drift	±0.015% of full scale/°C	
Output tolerance - repeatable after stabilization time	±0.5 % of full scale	
Output tolerance - output voltage drop	±1% of full scale	
Output tolerance - nonlinear	±0.2% of full scale	
Output tolerance - output ripple	1 LSB maximum	
Output tolerance - overshoot	0%	
Output tolerance - total deviation	±1 % of full scale	
Resolution	12 bits (4096 increments)	
Output value of LSB	2.5 mV	4.8 μA
Data type in application program	0 to 4095 Scalable to -32768 to 32767	
External power supply connection	Detected ¹	Detected ¹
Noise resistance - cable	Twisted-pair shielded cable is necessary	
Isolation between output and external power supply	500 Vac	
Isolation between output and power supply	500 Vac	
Isolation between output, external power supply and internal logic circuits	Photocoupler between output and internal circuit (500 Vac)	

Characteristic	Voltage output	Current output
Selection of analog output signal type	Using programming software	
Calibration or verification to maintain rated accuracy	Approximately 10 years	

NOTE:

1. When the external 24 Vdc is not connected, a corresponding error code is stored to a data register allocated to analog I/O operating status.

Connecting the TM2AMO1HT Module

Wiring Requirements

See Wiring Requirements (*see page 28*).

TM2AMO1HT Wiring Diagram

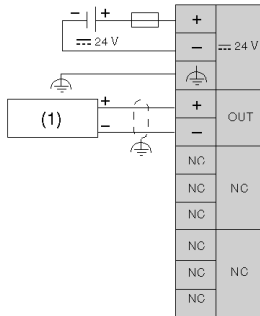

(1) Voltage/current preactuator

Use the braid supplied with the module to connect the functional ground.

Connect an appropriate fuse for the applied voltage and current draw, at the position shown in the diagram.

Use shielded, properly grounded cables for all analog and high-speed inputs or outputs and communication connections. If you do not use shielded cable for these connections, electromagnetic interference can cause signal degradation. Degraded signals can cause the controller or attached modules and equipment to perform in an unintended manner.

⚠ WARNING

UNINTENDED EQUIPMENT OPERATION

- Use shielded cables for all fast I/O, analog I/O and communication signals.
- Ground cable shields for all analog I/O, fast I/O and communication signals at a single point¹.
- Route communication and I/O cables separately from power cables.

Failure to follow these instructions can result in death, serious injury, or equipment damage.

¹Multipoint grounding is permissible if connections are made to an equipotential ground plane dimensioned to help avoid cable shield damage in the event of power system short-circuit currents.

 **WARNING**

UNINTENDED EQUIPMENT OPERATION

Do not connect wires to unused terminals and/or terminals indicated as “No Connection (N.C.)”.

Failure to follow these instructions can result in death, serious injury, or equipment damage.

NOTE: To help avoid interference of the analog signals, the power supply of the module must be turned on or off at the same time than the base controller power supply.

 **WARNING**

UNINTENDED EQUIPMENT OPERATION

Turn the power supplies for the module and the associated controller on and off at the same time.

Failure to follow these instructions can result in death, serious injury, or equipment damage.

Chapter 11

TM2AVO2HT Analog Output Module

Overview

This chapter describes the **TM2AVO2HT** module, its characteristics and its connection to the different sensors.

What Is in This Chapter?

This chapter contains the following topics:

Topic	Page
Presentation of the TM2AVO2HT Module	100
Characteristics of the TM2AVO2HT Module	101
Connecting the TM2AVO2HT Module	104

Presentation of the TM2AVO2HT Module

TM2AVO2HT Main Characteristics

Number of output channels	2
Signal type	Voltage
Output range	± 10 Vdc
Resolution	11 bits + sign
Connection type	Removable screw terminal block

Characteristics of the TM2AVO2HT Module

Introduction

This section provides a description of the electrical and the output characteristics of the TM2AVO2HT module.

DANGER

FIRE HAZARD

- Use only the correct wire sizes for the current capacity of the I/O channels and power supplies.
- For relay output (2 A) wiring, use conductors of at least 0.5 mm² (AWG 20) with a temperature rating of at least 80 °C (176 °F).
- For common conductors of relay output wiring (7 A), or relay output wiring greater than 2 A, use conductors of at least 1.0 mm² (AWG 16) with a temperature rating of at least 80 °C (176 °F).

Failure to follow these instructions will result in death or serious injury.

WARNING

UNINTENDED EQUIPMENT OPERATION

Do not exceed any of the rated values specified in the environmental and electrical characteristics tables.

Failure to follow these instructions can result in death, serious injury, or equipment damage.

Dimensions

The following diagrams show the dimensions for the TM2AVO2HT analog output module.

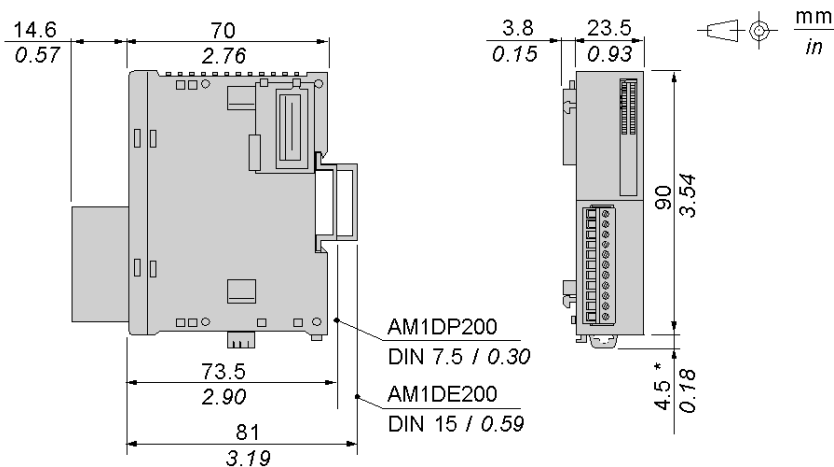

NOTE: * 8.5 mm (0.33 in) when the clip-on lock is pulled out.

TM2AVO2HT General Characteristics

Rated power supply voltage	24 Vdc
Power supply range	19.2...30 Vdc including ripple
Connector insertion/removal durability	100 times minimum
Internal 5 Vdc current draw	50 mA
Internal 24 Vdc current draw	0 mA
External 24 Vdc current draw	60 mA
Weight	85 g (3 oz)

TM2AVO2HT Output Characteristics

Characteristic	Voltage output
Output range	± 10 Vdc
Load impedance	3 kΩ min
Application load type	Resistive load
Settling time	2 ms
Total output system transfer Time	2 ms + 1 scan time
Output tolerance - maximum deviation at 25°C (77°F)	±0.5% of full scale
Output tolerance - temperature drift	±0.01% of full scale/°C
Output tolerance - repeatable after stabilization time	±0.1% of full scale
Output tolerance - output voltage drop	±0.5% of full scale
Output tolerance - nonlinear	±0.2% of full scale
Output tolerance - output ripple	1 LSB maximum
Output tolerance - overshoot	0%
Output tolerance - total deviation	±1% of full scale
Resolution	11 bits + sign
Output value of LSB	± 9.8 mV
Data type in application program	-2,048 to 2,047 Scalable to -32768 to 32767 ¹
Current loop open	Not detectable
Noise resistance - maximum temporary deviation during perturbations	±1% of full scale
Noise resistance - cable	Twisted-pair shielded cable is necessary
Isolation between outputs	None
Isolation between outputs and external power supply	None
Isolation between outputs, external power supply and internal logic circuits	Photocoupler between output and internal circuit (2500 Vac)
Selection of analog output signal type	Using programming software
Calibration or verification to maintain rated accuracy	Approximately 10 years

NOTE:

1. The 12-bit data (0 to 4095) processed in the Analog I/O module can be linear-converted to a value between -32768 and 32767. The optional range designation and analog I/O data minimum and maximum values can be selected using data registers allocated to analog I/O modules.

Connecting the TM2AVO2HT Module

Wiring Requirements

See Wiring Requirements (*see page 28*).

TM2AVO2HT Wiring Diagram

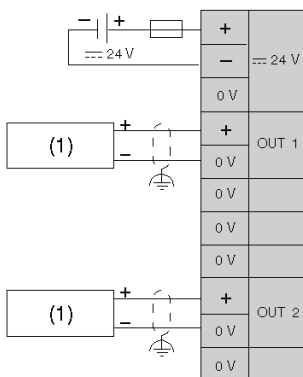

(1) Voltage/current preactuator

Use the braid supplied with the module to connect the functional ground.

Connect an appropriate fuse for the applied voltage and current draw, at the position shown in the diagram.

Use shielded, properly grounded cables for all analog and high-speed inputs or outputs and communication connections. If you do not use shielded cable for these connections, electromagnetic interference can cause signal degradation. Degraded signals can cause the controller or attached modules and equipment to perform in an unintended manner.

⚠ WARNING

UNINTENDED EQUIPMENT OPERATION

- Use shielded cables for all fast I/O, analog I/O and communication signals.
- Ground cable shields for all analog I/O, fast I/O and communication signals at a single point¹.
- Route communication and I/O cables separately from power cables.

Failure to follow these instructions can result in death, serious injury, or equipment damage.

¹Multipoint grounding is permissible if connections are made to an equipotential ground plane dimensioned to help avoid cable shield damage in the event of power system short-circuit currents.

 **WARNING**

UNINTENDED EQUIPMENT OPERATION

Do not connect wires to unused terminals and/or terminals indicated as “No Connection (N.C.)”.

Failure to follow these instructions can result in death, serious injury, or equipment damage.

NOTE: To help avoid interference of the analog signals, the power supply of the module must be turned on or off at the same time than the base controller power supply.

 **WARNING**

UNINTENDED EQUIPMENT OPERATION

Turn the power supplies for the module and the associated controller on and off at the same time.

Failure to follow these instructions can result in death, serious injury, or equipment damage.

Chapter 12

TM2AMM3HT Analog Mixed I/O Module

Overview

This chapter describes the **TM2AMM3HT** module, its characteristics and its connection to the different sensors.

What Is in This Chapter?

This chapter contains the following topics:

Topic	Page
Presentation of the TM2AMM3HT Module	108
Characteristics of the TM2AMM3HT Module	109
Connecting the TM2AMM3HT Module	114

Presentation of the TM2AMM3HT Module

TM2AMM3HT Main Characteristics

Number of I/O channels	2 Inputs		1 Output	
Signal type	Voltage	Current	Voltage	Current
Range	0...10 Vdc (non differential)	4...20 mA (non differential)	0...10 Vdc	4...20 mA
Resolution	12 bits (4096 points)			
Connection type	Removable screw terminal block			

Characteristics of the TM2AMM3HT Module

Introduction

This section provides a description of the electrical and the I/O characteristics of the **TM2AMM3HT** module.

DANGER

FIRE HAZARD

- Use only the correct wire sizes for the current capacity of the I/O channels and power supplies.
- For relay output (2 A) wiring, use conductors of at least 0.5 mm² (AWG 20) with a temperature rating of at least 80 °C (176 °F).
- For common conductors of relay output wiring (7 A), or relay output wiring greater than 2 A, use conductors of at least 1.0 mm² (AWG 16) with a temperature rating of at least 80 °C (176 °F).

Failure to follow these instructions will result in death or serious injury.

WARNING

UNINTENDED EQUIPMENT OPERATION

Do not exceed any of the rated values specified in the environmental and electrical characteristics tables.

Failure to follow these instructions can result in death, serious injury, or equipment damage.

Dimensions

The following diagrams show the dimensions for the TM2AMM3HT analog I/O module.

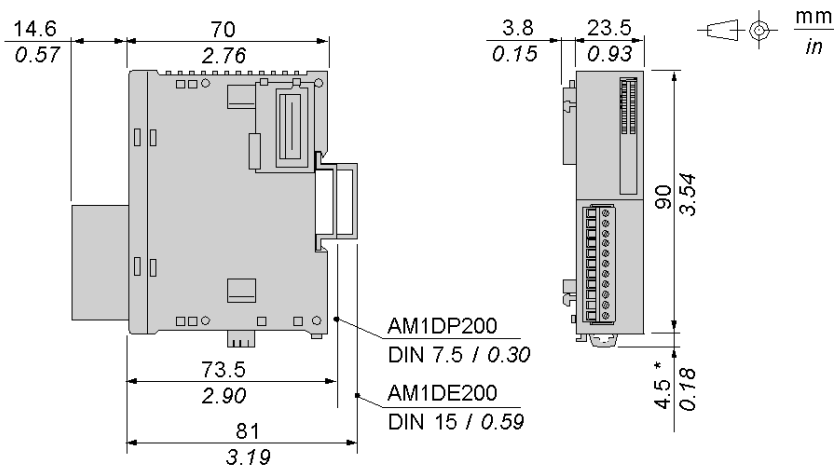

NOTE: * 8.5 mm (0.33 in) when the clip-on lock is pulled out.

TM2AMM3HT General Characteristics

Rated power supply voltage	24 Vdc
Power supply range	19.2 ... 30 Vdc including ripple
Connector insertion/removal durability	100 times minimum
Internal 5 Vdc current draw	50 mA
Internal 24 Vdc current draw	0 mA
External 24 Vdc current draw	50 mA
Weight	85 g (3 oz)

TM2AMM3HT Input Characteristics

Characteristic	Voltage input	Current input
Input range	0...10 Vdc	4...20 mA
Input impedance	1 M Ω min.	10 Ω
Sample duration time	10 ms max.	
Total input system transfer time	60 ms + 1 scan time	
Input type	Nondifferential	
Operating mode	Self-scan	
Conversion mode	$\Sigma\Delta$ type ADC	
Input tolerance - maximum deviation at 25°C (77°F)	± 0.2 % of full scale	
Input tolerance - temperature drift	± 0.006 % of full scale/°C	
Input deviation - repeatable after stabilization time	± 0.5 % of full scale	
Input tolerance - nonlinear	± 0.2 % of full scale	
Input tolerance - maximum deviation	± 1 % of full scale	
Resolution	12 bits (4096 increments)	
Input value of LSB	2.5 mV	4.8 μ A
Data type in application program	0 to 4095 Scalable to -32768 to 32767 ¹	
Input data out of range detection	Yes ²	
Noise resistance - maximum temporary deviation during perturbations	± 1 % of full scale when a 500 Vdc clamp voltage is applied to the power and I/O wiring	
Noise resistance - cable	Twisted-pair shielded cable is necessary	
Noise resistance - crosstalk	2 LSB maximum	
Isolation between inputs	None	
Isolation between inputs and power supply	500 Vac	

Characteristic	Voltage input	Current input
Isolation between inputs, external power supply and internal logic circuits	Photocoupler between input and internal circuit (500 Vac)	
Maximum continuous allowed overload (no damage)	13 Vdc	40 mA
Selection of analog input signal type	Choose current and voltage types using programming software	
Calibration or verification to maintain rated accuracy	Approximately 10 years	

NOTE:

1. The 12-bit data (0 to 4095) processed in the Analog I/O module can be linear-converted to a value between -32768 and 32767. The optional range designation and analog I/O data minimum and maximum values can be selected using data registers allocated to analog I/O modules.
2. When an input error is detected, a corresponding error code is stored to a data register allocated to analog I/O operating status.

TM2AMM3HT Output Characteristics

Characteristic	Voltage output	Current output
Output range	0...10 Vdc	4...20 mA
Load impedance	2 k Ω minimum	300 Ω maximum
Application load type	Resistive load	
Settling time	10 ms	
Total output system transfer Time	10 ms + 1 scan time	
Output tolerance - maximum deviation at 25°C (77°F)	± 0.2 % of full scale	
Output tolerance- temperature drift	± 0.015 % of full scale/°C	
Output tolerance - repeatable after stabilization time	± 0.5 % of full scale	
Output tolerance - output voltage drop	± 1 % of full scale	
Output tolerance - nonlinear	± 0.2 % of full scale	
Output tolerance - output ripple	1 LSB maximum	
Output tolerance - overshoot	0%	
Output tolerance - total error	± 1 % of full scale	
Resolution	12 bits (4096 increments)	

Characteristic	Voltage output	Current output
Output value of LSB	2.5 mV	4.8 μ A
Data type in application program	0 to 4095 Scalable to -32768 to 32767 ¹	
External power supply connection	Detected ²	Detected ²
Noise resistance - maximum temporary deviation during perturbations	1% of full scale	
Noise resistance - cable	Twisted-pair shielded cable is necessary for improved noise immunity	
Isolation between output and external power supply	500 Vac	
Isolation between output, external power supply and internal logic circuits	500 Vac by photocoupler	
Selection of analog output signal type	Using programming software	
Calibration or verification to maintain rated accuracy	Approximately 10 years	

NOTE:

1. The 12-bit data (0 to 4095) processed in the Analog I/O module can be linear-converted to a value between -32768 and 32767. The optional range designation and analog I/O data minimum and maximum values can be selected using data registers allocated to analog I/O modules.
2. When the external 24 Vdc is not connected, a corresponding error code is stored to a data register allocated to analog I/O operating status.

Connecting the TM2AMM3HT Module

Wiring Requirements

See Wiring Requirements (*see page 28*).

TM2AMM3HT Wiring Diagram

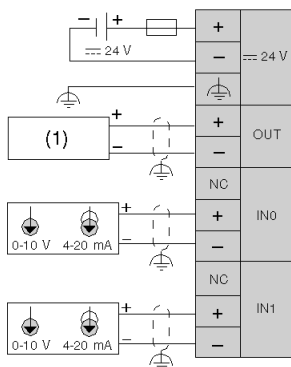

(1) Voltage/current preactuator

Use the braid supplied with the module to connect the functional ground.

Connect an appropriate fuse for the applied voltage and current draw, at the position shown in the diagram.

NOTE: The (-) poles of inputs IN0 and IN1 are connected internally.

Use shielded, properly grounded cables for all analog and high-speed inputs or outputs and communication connections. If you do not use shielded cable for these connections, electromagnetic interference can cause signal degradation. Degraded signals can cause the controller or attached modules and equipment to perform in an unintended manner.

⚠ WARNING

UNINTENDED EQUIPMENT OPERATION

- Use shielded cables for all fast I/O, analog I/O and communication signals.
- Ground cable shields for all analog I/O, fast I/O and communication signals at a single point¹.
- Route communication and I/O cables separately from power cables.

Failure to follow these instructions can result in death, serious injury, or equipment damage.

¹Multipoint grounding is permissible if connections are made to an equipotential ground plane dimensioned to help avoid cable shield damage in the event of power system short-circuit currents.

 **WARNING**

UNINTENDED EQUIPMENT OPERATION

Do not connect wires to unused terminals and/or terminals indicated as “No Connection (N.C.)”.

Failure to follow these instructions can result in death, serious injury, or equipment damage.

NOTE: To help avoid interference of the analog signals, the power supply of the module must be turned on or off at the same time than the base controller power supply.

 **WARNING**

UNINTENDED EQUIPMENT OPERATION

Turn the power supplies for the module and the associated controller on and off at the same time.

Failure to follow these instructions can result in death, serious injury, or equipment damage.

Chapter 13

TM2AMM6HT Analog Mixed I/O Module

Overview

This chapter describes the **TM2AMM6HT** module, its characteristics and its connection to the different sensors.

What Is in This Chapter?

This chapter contains the following topics:

Topic	Page
Presentation of the TM2AMM6HT Module	118
Characteristics of the TM2AMM6HT Module	119
Connecting the TM2AMM6HT Module	123

Presentation of the TM2AMM6HT Module

TM2AMM6HT Main Characteristics

Number of I/O channels	4 Inputs		2 Outputs	
Signal type	Voltage	Current	Voltage	Current
Range	0...10 Vdc (non differential)	4...20 mA (non differential)	0...10 Vdc	4...20 mA
Resolution	12 bits (4096 points)			
Connection type	Removable screw terminal block			

Characteristics of the TM2AMM6HT Module

Introduction

This section provides a description of the electrical and the I/O characteristics of the **TM2AMM6HT** module.

⚠ DANGER

CURRENT OVERLOAD AND FIRE POTENTIAL

Select and install the appropriate wire size for the electrical current ratings of the I/O channels.

Failure to follow these instructions will result in death or serious injury.

⚠ WARNING

UNINTENDED EQUIPMENT OPERATION

Do not exceed any of the rated values specified in this chapter.

Failure to follow these instructions can result in death, serious injury, or equipment damage.

Dimensions

The following diagrams show the dimensions for the TM2AMM6HT analog I/O module.

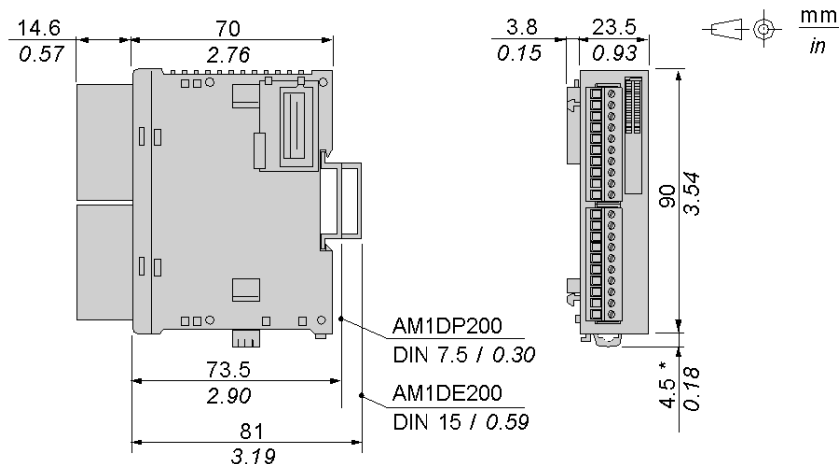

NOTE: * 8.5 mm (0.33 in) when the clip-on lock is pulled out.

TM2AMM6HT General Characteristics

Rated power supply voltage	24 VDC
Power supply range	19.2...30 VDC including ripple
Connector insertion/removal durability	100 times minimum
Internal 5 VDC current draw	60 mA
Internal 24 VDC current draw	0 mA
External 24 VDC current draw	80 mA
Weight	85 g (3 oz)

TM2AMM6HT Input Characteristics

Characteristic	Voltage input	Current input
Input range	0...10 VDC	4...20 mA
Input impedance	1 M Ω min	< 250 Ω
Sample duration time	64 ms max.	
Filtering	It is possible to adjust by software the acquisition time for each channel from 16 ms to 64 ms.	
Total input system transfer time	4 x 64 ms + 1 scan time ⁽¹⁾	
Input type	Nondifferential	
Operating mode	Self-scan	
Conversion mode	$\Sigma\Delta$ type ADC	
Input tolerance - maximum deviation at 25°C (77°F)	± 0.5 % of full scale	
Input tolerance - temperature drift	± 0.015 % of full scale/°C	
Input deviation - repeatable after stabilization time	± 0.5 % of full scale	
Input tolerance - nonlinear	± 0.4 % of full scale	
Input tolerance - maximum deviation	± 1 % of full scale	
Resolution	12 bits (4096 increments)	
Input value of LSB	2.5 mV	4.8 μ A
Data type in application program	0 to 4095 Scalable to -32768 to 32767 ⁽²⁾	
Input data out of range detection	Yes ³	
Input protection	Against reverse polarity and short circuit	
Noise resistance - maximum temporary deviation during perturbations	± 2 % of full scale	

Characteristic	Voltage input	Current input
Noise resistance - cable	Twisted-pair shielded cable is necessary	
Noise resistance - crosstalk	1 LSB maximum	
Isolation between inputs	None	
Isolation between inputs and outputs, between inputs and external power supply	800 VAC between inputs and outputs, between channels and PSU	
Isolation between inputs, power supply and internal logic circuits	Photocoupler between input and internal circuit (1500 VAC)	
Maximum continuous allowed overload (no damage)	30 VDC	40 mA
Selection of analog input signal type	Choose current and voltage types using programming software	
Calibration or verification to maintain rated accuracy	Approximately 10 years	

NOTE:

1. Total input system transfer time = sample duration time x active channel number + 1 scan time.
2. The 12-bit data (0 to 4095) processed in the Analog I/O module can be linear-converted to a value between -32768 and 32767. The optional range designation and analog I/O data minimum and maximum values can be selected using data registers allocated to analog I/O modules.
3. When an input error is detected, a corresponding error code is stored to a data register allocated to analog I/O operating status.

TM2AMM6HT Output Characteristics

Characteristic	Voltage output	Current output
Output range	0...10 VDC	4...20 mA
Load impedance	2 k Ω minimum	300 Ω maximum
Application load type	Resistive load	
Settling time	20 ms	
Total output system transfer Time	20 ms + 1 scan time	
Output tolerance - maximum deviation at 25°C (77°F)	±0.9 % of full scale	
Output tolerance - temperature drift	±0.015 % of full scale/°C	
Output deviation - repeatable after stabilization time	±1 % of full scale	
Output tolerance - output voltage drop	±1 % of full scale	
Output tolerance - nonlinear	±0.5 % of full scale	
Output tolerance - output ripple	±0.5% of full scale	

Characteristic	Voltage output	Current output
Output deviation - overshoot	±0.5% of full scale	
Output tolerance - total deviation	±1.5% of full scale	
Resolution	12 bits (4096 increments)	
Output value of LSB	2.5 mV	4.8 µA
Data type in application program	0 to 4095 Scalable to -32768 to 32767 ¹	
Noise resistance - maximum temporary deviation during perturbations	±1 % of full scale	
Noise resistance - cable	Twisted-pair shielded cable is necessary for improved noise immunity	
Noise resistance - crosstalk	0.1% of full scale maximum	
Isolation between inputs	None	
Isolation between outputs and external power supply	800 Vac	
Isolation between outputs and outputs	800 Vac	
Isolation between outputs and internal logic circuits	Photocoupler between output and internal circuit (1500 Vac)	
Selection of analog output signal type	Choose current and voltage types using programming software	
Calibration or verification to maintain rated accuracy	Approximately 10 years	

NOTE:

1. The 12-bit data (0 to 4095) processed in the Analog I/O module can be linear-converted to a value between -32768 and 32767. The optional range designation and analog I/O data minimum and maximum values can be selected using data registers allocated to analog I/O modules.

Connecting the TM2AMM6HT Module

Wiring Requirements

See Wiring Requirements ([see page 28](#)).

TM2AMM6HT Wiring Diagram

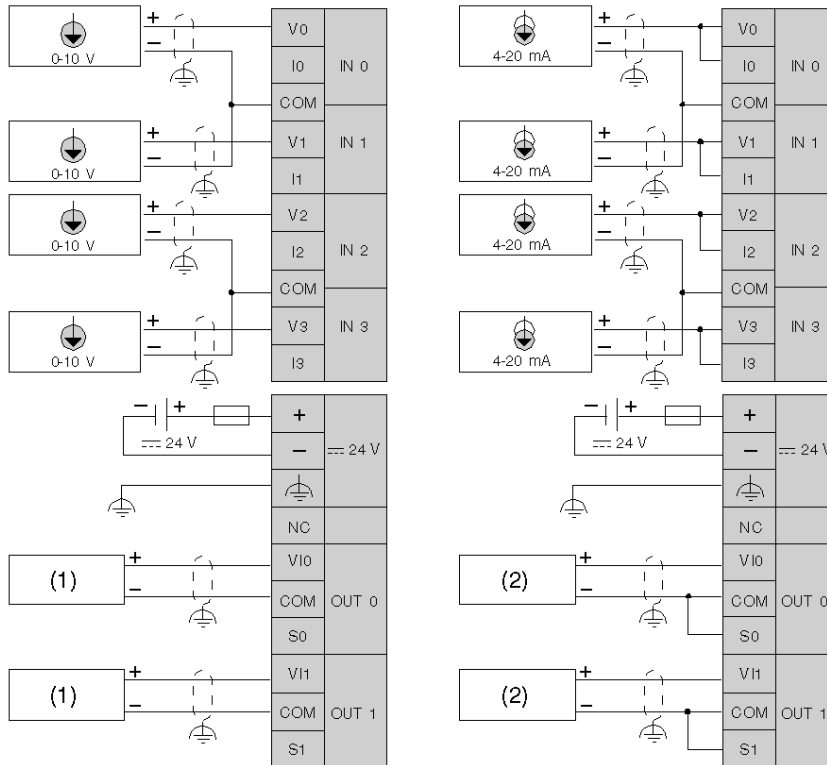

(1) Voltage preactuator

(2) Current preactuator

Use the braid supplied with the module to connect the functional ground.

Connect an appropriate fuse for the applied voltage and current draw, at the position shown in the diagram.

Use shielded, properly grounded cables for all analog and high-speed inputs or outputs and communication connections. If you do not use shielded cable for these connections, electromagnetic interference can cause signal degradation. Degraded signals can cause the controller or attached modules and equipment to perform in an unintended manner.

 WARNING

UNINTENDED EQUIPMENT OPERATION

- Use shielded cables for all fast I/O, analog I/O and communication signals.
- Ground cable shields for all analog I/O, fast I/O and communication signals at a single point¹.
- Route communication and I/O cables separately from power cables.

Failure to follow these instructions can result in death, serious injury, or equipment damage.

¹Multipoint grounding is permissible if connections are made to an equipotential ground plane dimensioned to help avoid cable shield damage in the event of power system short-circuit currents.

 WARNING

UNINTENDED EQUIPMENT OPERATION

Do not connect wires to unused terminals and/or terminals indicated as “No Connection (N.C.)”.

Failure to follow these instructions can result in death, serious injury, or equipment damage.

NOTE: To help avoid interference of the analog signals, the power supply of the module must be turned on or off at the same time than the base controller power supply.

 WARNING

UNINTENDED EQUIPMENT OPERATION

Turn the power supplies for the module and the associated controller on and off at the same time.

Failure to follow these instructions can result in death, serious injury, or equipment damage.

Chapter 14

TM2ALM3LT Analog Mixed I/O Module

Overview

This chapter describes the **TM2ALM3LT** module, its characteristics and its connection to the different sensors.

What Is in This Chapter?

This chapter contains the following topics:

Topic	Page
Presentation of the TM2ALM3LT Module	126
Characteristics of the TM2ALM3LT Module	127
Connecting the TM2ALM3LT Module	132

Presentation of the TM2ALM3LT Module

TM2ALM3LT Main Characteristics

Number of I/O channels	2 inputs		1 output	
Signal/sensor type	Thermocouple	Temperature probe	Voltage	Current
Input type	Type J, K and T	Pt100	0...10 Vdc	4...20 mA
Resolution	12 bits (4096 points)			
Connection type	Removable screw terminal block			

Characteristics of the TM2ALM3LT Module

Introduction

This section provides a description of the electrical and the I/O characteristics of the **TM2ALM3LT** module.

DANGER

FIRE HAZARD

- Use only the correct wire sizes for the current capacity of the I/O channels and power supplies.
- For relay output (2 A) wiring, use conductors of at least 0.5 mm² (AWG 20) with a temperature rating of at least 80 °C (176 °F).
- For common conductors of relay output wiring (7 A), or relay output wiring greater than 2 A, use conductors of at least 1.0 mm² (AWG 16) with a temperature rating of at least 80 °C (176 °F).

Failure to follow these instructions will result in death or serious injury.

WARNING

UNINTENDED EQUIPMENT OPERATION

Do not exceed any of the rated values specified in the environmental and electrical characteristics tables.

Failure to follow these instructions can result in death, serious injury, or equipment damage.

Dimensions

The following diagrams show the dimensions for the TM2ALM3LT analog I/O module.

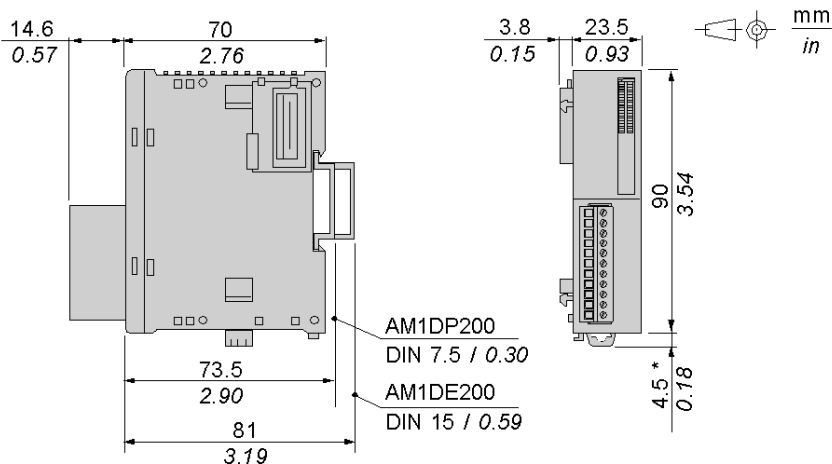

NOTE: * 8.5 mm (0.33 in) when the clip-on lock is pulled out.

TM2ALM3LT General Characteristics

Rated power voltage	24 Vdc
Allowable voltage range	19.2...30 Vdc including ripple
Connector insertion/removal durability	100 times minimum
Internal 5 Vdc current draw	50 mA
Internal 24 Vdc current draw	0 mA
External 24 Vdc current draw	80 mA
Weight	85 g (3 oz)

TM2ALM3LT Input Characteristics

Characteristic	Thermocouple input	Temperature probe input
Input range	Type K: 0...1300 °C (32...2372 °F) Type J: 0...1200 °C (32...2192 °F) Type T: 0...400 °C (32...752 °F)	(RTD) Pt 100 3-wire type -100...500 °C (-148...932 °F)
Input impedance	250 Ω min (TBC)	1 MΩ min
Sample duration time	20 ms max	
Total input system transfer time	80 ms + 1 scan time	
Input type	Differential	
Operating mode	Self-scan	
Conversion mode	ΣΔ type ADC	
Input tolerance - maximum deviation at 25°C (77°F)	±0.2 % of full scale plus reference junction compensation accuracy ±4°C max	±0.2 % of full scale
Input tolerance - temperature drift	±0.006 % of full scale/°C	
Input tolerance - repeatable after stabilization time	±0.5 % of full scale	
Input tolerance - nonlinear	±0.2 % of full scale	
Input tolerance - maximum deviation	±1 % of full scale	
Resolution	Type K and J: 14 bits Type T: 12 bits	
Input value of LSB	K: 0.1 °C (32.18 °F) J: 0.1 °C (32.18 °F) T: 0.1 °C (32.18 °F)	0.1 °C (32.18 °F)
Data type in application program	0 to 4095 Scalable to -32768 to 32767 ¹	
Input data out of range detection	Yes ²	
Noise resistance - maximum temporary deviation during perturbations	±3 % maximum when a 500 Vdc clamp voltage is applied to the power and I/O wiring	PT 100: ±1% of full scale

Characteristic	Thermocouple input	Temperature probe input
Noise resistance - cable	Twisted-pair shielded cable is necessary	
Isolation between output and external power supply	500 Vac	
Isolation between output, power supply and internal logic circuits	500 Vac by photocoupler	
Selection of analog input signal type	Using software programming. It is possible to mix the type of input on the module.	
Calibration or verification to maintain rated accuracy	Approximately 10 years	

NOTE:

1. The 12, 13 or 14-bit data (0 to 4095) and 10-bit data (0 to 1023) processed in the Analog I/O module can be linear-converted to a value between -32768 and 32767. The optional range designation and analog I/O data minimum and maximum values can be selected using data registers allocated to analog I/O modules.
2. When an input error is detected, a corresponding error code is stored to a data register allocated to analog I/O operating status.

TM2ALM3LT Output Characteristics

Characteristic	Voltage output	Current output
Output range	0...10 Vdc	4...20 mA
Load impedance	> 2 kΩ	300 Ω maximum
Application load type	Resistive load	
Settling time	10 ms	
Total output system transfer Time	10 ms + 1 scan time	
Output tolerance - maximum deviation at 25°C (77°F)	±0.2% of full scale	
Output tolerance - temperature drift	±0.015% of full scale/°C	
Output tolerance - repeatable after stabilization time	±0.5 % of full scale	
Output tolerance - output voltage drop	±1% of full scale	
Output tolerance - nonlinear	±0.2% of full scale	

Characteristic	Voltage output	Current output
Output tolerance - output ripple	1 LSB maximum	
Output tolerance - overshoot	0%	
Output tolerance - total deviation	±1% of full scale	
Resolution	12 bits (4096 increments)	
Output value of LSB	2.5 mV	4.8 µA
Data type in application program	0 to 4095 Scalable to -32768 to 32767 ¹	
External power supply connection	Detected	Detected ²
Noise resistance - maximum temporary deviation during perturbations	±1% of full scale	
Noise resistance - cable	Twisted-pair shielded cable is necessary	
Isolation between output and external power supply	500 Vac	
Isolation between inputs, power supply and internal logic circuits	500 Vac by photocoupler	
Selection of analog output signal type	Using programming software	
Calibration or verification to maintain rated accuracy	Approximately 10 years	

NOTE:

1. The 12-bit data (0 to 4095) and 10-bit data (0 to 1023) processed in the Analog I/O module can be linear-converted to a value between -32768 and 32767. The optional range designation and analog I/O data minimum and maximum values can be selected using data registers allocated to analog I/O modules.
2. When an output error is detected, a corresponding error code is stored to a data register allocated to analog I/O operating status.

Connecting the TM2ALM3LT Module

Wiring Requirements

See Wiring Requirements ([see page 28](#)).

TM2ALM3LT Wiring Diagram

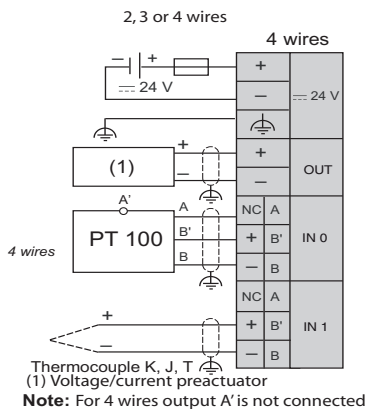

To use the braid supplied with the module to connect the functional ground.

- Connect an appropriate fuse for the applied voltage and current draw, at the position shown in the diagram.
- When connecting an PT100 temperature probe, connect the wires to terminals A, B', and B of input channel 0 or 1.
- When connecting a thermocouple, connect the two wires to terminals B' and B of input channel 0 or 1.

⚠ DANGER**FIRE HAZARD**

- Use only the correct wire sizes for the current capacity of the I/O channels and power supplies.
- For relay output (2 A) wiring, use conductors of at least 0.5 mm² (AWG 20) with a temperature rating of at least 80 °C (176 °F).
- For common conductors of relay output wiring (7 A), or relay output wiring greater than 2 A, use conductors of at least 1.0 mm² (AWG 16) with a temperature rating of at least 80 °C (176 °F).

Failure to follow these instructions will result in death or serious injury.

Use shielded, properly grounded cables for all analog and high-speed inputs or outputs and communication connections. If you do not use shielded cable for these connections, electromagnetic interference can cause signal degradation. Degraded signals can cause the controller or attached modules and equipment to perform in an unintended manner.

⚠ WARNING**UNINTENDED EQUIPMENT OPERATION**

- Use shielded cables for all fast I/O, analog I/O and communication signals.
- Ground cable shields for all analog I/O, fast I/O and communication signals at a single point¹.
- Route communication and I/O cables separately from power cables.

Failure to follow these instructions can result in death, serious injury, or equipment damage.

¹Multipoint grounding is permissible if connections are made to an equipotential ground plane dimensioned to help avoid cable shield damage in the event of power system short-circuit currents.

⚠ WARNING**UNINTENDED EQUIPMENT OPERATION**

Do not connect wires to unused terminals and/or terminals indicated as “No Connection (N.C.)”.

Failure to follow these instructions can result in death, serious injury, or equipment damage.

NOTE: To help avoid interference of the analog signals, the power supply of the module must be turned on or off at the same time than the base controller power supply.

 **WARNING**

UNINTENDED EQUIPMENT OPERATION

Turn the power supplies for the module and the associated controller on and off at the same time.

Failure to follow these instructions can result in death, serious injury, or equipment damage.

Chapter 15

Certifications and Standards

Certifications and Standards

Introduction

TM2 Analog I/O modules comply with the main national and international standards concerning electronic industrial control devices.

Reference	CE	TüV IEC EN 61131-2	cULus Class I, Div. 2	cCSAus Class I, Div. 2	DNV-GL	LR
TM2ALM3LT	X	X	X	X	X	X
TM2AMI2HT	X	X	X	X	X	X
TM2AMI2LT	X	–	X	X	–	–
TM2AMI4LT	X	–	X	X	–	–
TM2AMI8HT	X	–	X	X	–	–
TM2AMM3HT	X	X	X	X	X	X
TM2AMM6HT	X	–	X	X	–	–
TM2AMO1HT	X	X	X	X	X	X
TM2ARI8HT	X	–	X	X	–	–
TM2AVO2HT	X	–	X	X	–	–
TM2ARI8LRJ	X	–	–	X	–	–
TM2ARI8LT	X	–	X	X	–	–



D

DIN

Deutsches Institut für Normung is a German institution that sets engineering and dimensional standards.

E

expansion connector

A connector to attach expansion I/O modules.



A

- Accessories, 18
- Analog I/O modules, 15
 - Characteristics, 15
 - Physical description, 17
- Assembling to a controller, 22

C

- certifications and standards, 135
- Characteristics
 - Analog I/O modules, 15
- Controllers
 - Disassembling a module, 24

D

- Dimensions
 - TM2ALM3LT, 128
 - TM2AMI2HT, 38
 - TM2AMI2LT, 46
 - TM2AMI4LT, 54
 - TM2AMI8HT, 62
 - TM2AMM3HT, 110
 - TM2AMM6HT, 119
 - TM2AMO1HT, 94
 - TM2ARI8HT, 70
 - TM2ARI8LRJ, 78
 - TM2ARI8LT, 86
 - TM2AVO2HT, 102

G

- General characteristics
 - TM2ALM3LT, 128
 - TM2AMI2HT, 38
 - TM2AMI2LT, 46
 - TM2AMI4LT, 54
 - TM2AMI8HT, 62
 - TM2AMM3HT, 110
 - TM2AMM6HT, 120
 - TM2AMO1HT, 94
 - TM2ARI8HT, 70
 - TM2ARI8LRJ, 78
 - TM2ARI8LT, 86
 - TM2AVO2HT, 102

I

- Input characteristics
 - TM2ALM3LT, 129
 - TM2AMI2HT, 39
 - TM2AMI2LT, 47
 - TM2AMI4LT, 55
 - TM2AMI8HT, 62
 - TM2AMM3HT, 111
 - TM2AMM6HT, 120
 - TM2ARI8HT, 71
 - TM2ARI8LRJ, 79
 - TM2ARI8LT, 87

M

- Mounting Position, 21
- Mounting rail
 - 15 mm AM1DE200 rail, 18
 - 725 mm AM1DP200 rail, 18

O

Output characteristics

- TM2ALM3LT, 130
- TM2AMM3HT, 112
- TM2AMM6HT, 121
- TM2AMO1HT, 95
- TM2AVO2HT, 103

P

Physical description

- Connector RJ11, 17
- Terminal block, 17

T

Terminal Block End Clamp type AB1AB8P35, 18

TM2 analog

- TM2ALM3LT, 125
- TM2AMI2HT, 35
- TM2AMI2LT, 43
- TM2AMI4LT, 51
- TM2AMI8HT, 59
- TM2AMM3HT, 107
- TM2AMM6HT, 117
- TM2AMO1HT, 91
- TM2ARI8HT, 67
- TM2ARI8LRJ, 75
- TM2ARI8LTARI8LT, 83
- TM2AVO2HT, 99

TM2 I/O modules

Environmental Characteristics, 33

- TM2ALM3LT, 125, 126, 127, 132
- TM2AMI2HT, 35, 36, 37, 41
- TM2AMI2LT, 43, 44, 45, 49
- TM2AMI4LT, 51, 52, 53, 57
- TM2AMI8HT, 59, 60, 61, 64
- TM2AMM3HT, 107, 108, 109, 114
- TM2AMM6HT, 117, 118, 119, 123
- TM2AMO1HT, 91, 92, 93, 97
- TM2ARI8HT, 67, 68, 69, 72
- TM2ARI8LRJ, 75, 76, 77, 81
- TM2ARI8LT, 84, 85, 89
- TM2ARI8LTARI8LT, 83

TM2AVO2HT, 100

TM2AVO2HT, 99, 101, 104

TM2XMTGB, 19

TWDXMT5 mounting strip, 19

W

Wiring diagram

- TM2ALM3LT, 132
 - TM2AMI2HT, 41
 - TM2AMI2LT, 49
 - TM2AMI4LT, 57
 - TM2AMI8HT, 64
 - TM2AMM3HT, 114
 - TM2AMM6HT, 123
 - TM2AMO1HT, 97
 - TM2ARI8HT, 72
 - TM2ARI8LRJ, 81
 - TM2ARI8LT, 89
 - TM2AVO2HT, 104
- wiring requirements, 28