

1A PowerPlus™ Panelboards

Lighting and Heat Tracing EPL Series (Div. 1 & 2) D2L Series (Div. 2)

EPL Series:
Cl. I, Div. 1 & 2, Groups B†, C, D
Cl. I, Zone 1 & 2, IIB + H₂†
Cl. II, Div. 1, Groups E, F, G
Cl. II, Div. 2, Groups F, G
Cl. III
NEMA/EEMAC 3, 4, 4X‡, 7B†CD, 9EFG, 12

D2L Series:
Cl. I, Div. 2, Groups B†, C, D
Cl. I, Zone 2, IIB + H₂†
Cl. II, Div. 2, Groups F, G
Cl. III
NEMA/EEMAC: 3, 4, 4X‡, 7B†CD, 12

PowerPlus™ Series Panelboards provide both premium factory-sealed and value non-factory-sealed solutions for the protection and distribution of lighting, power, and heat tracing circuits. This panel solution is designed, engineered, and manufactured to be the industry's safest and most dependable panelboard for hazardous area locations.

PowerPlus Premium and Value Solutions

- **Premium Solution:** PowerPlus factory-sealed panelboards are premium panelboards that provide maximum circuit flexibility with labor savings during installation, operation, and maintenance, and are accommodating for future changes in the field (order with either "S" or "A" in base part number). Panels are pre-wired to maximum circuit capacity, allowing for easy and safe replacement or installation of components in the field, while maintaining factory-sealed integrity.
- **Value Solution:** PowerPlus non-factory-sealed panelboards are value panelboards that offer maximum circuit flexibility and many of the same features and benefits of the PowerPlus premium line. This value solution is provided without terminal housing and factory wiring of circuits with "N" in base part number). The non-factory-sealed solution reduces initial panelboard material costs and requires field wiring to circuit breakers and external seals to be field-installed during installation.

Applications:

EPL and D2L PowerPlus™ panelboards are used:

- In areas made hazardous by the continuous or abnormal presence of flammable gases, vapors, and combustible dusts
- In areas subject to weather, dampness, and corrosion
- For branch power distribution and circuit protection to motors, valves, pumps, lighting, heat tracing, receptacles, etc.
- For indoor and outdoor applications in petroleum refineries, chemical and petrochemical plants, and other process industry facilities where similar hazards exist
- To accommodate up to 100 amp branch loads (only 3 circuits), balance is up to 50 amps

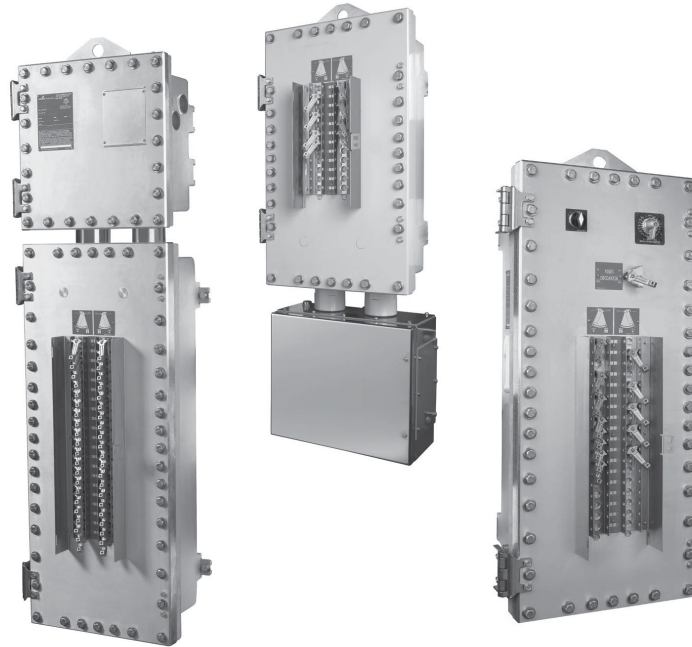

Certifications and Compliances:

EPL Series:

- NEC/CEC:
 - Class I, Division 1 & 2, Groups B†, C, D
 - Class I, Zone 1 & 2, IIB + H₂†
 - Class II, Division 1, Groups E, F, G
 - Class II, Division 2, Groups F, G
 - Class III
- NEMA/EEMAC: 3, 4, 4X‡, 7B†CD, 9EFG, 12
- CSA Enc. 3, 4, 5
- UL Standard: 67, 1203
- cUL (to CSA Standard C22.2 Nos. 29 & 30)
- IP65

D2L Series (Division 2):

- NEC/CEC:
 - Class I, Division 2, Groups B†, C, D
 - Class I, Zone 2, IIB + H₂†
 - Class II, Division 2, Groups F, G
 - Class III
- NEMA/EEMAC: 3, 4, 4X‡, 7B†CD, 12
- CSA Enc. 3, 4, 5
- UL Standard: 67, 1203
- cUL (to CSA Standard C22.2 Nos. 29 & 30)
- IP65

Standard Materials and Finishes:

- Circuit breaker enclosure body and cover – copper-free aluminum
- Terminal housing – type 316L stainless steel ("S") or copper-free aluminum ("A")
- Gasket – neoprene (cast aluminum enclosure); foam-in-place (stainless steel enclosure)
- Operating handles – copper-free aluminum
- Operating shafts and bushings, cover bolts, washers, hinges, breather/drain, retractile springs – stainless steel
- Circuit breaker operators – non-metallic
- Lifting bracket – electrogalvanized cold rolled steel
- Chassis – silver-plated copper
- Breather cap – Delrin® non-metallic material
- Neutral and ground bar – tin-plated aluminum

† Group B and IIB + H₂ is standard on all PowerPlus panels, but requires special brackets to be installed on breakers to ensure long-term operability of circuit breakers.

To order with brackets installed at factory, add suffix -GB. For field installable kit, order EPL-GB-KIT separately.

‡ NEMA 4X rating is available when ordered with suffix S752 or S753.

Delrin® is a registered trademark of DuPont.

PowerPlus™ Panelboards

Lighting and Heat Tracing EPL Series (Div. 1 & 2) D2L Series (Div. 2)

EPL Series:
Cl. I, Div. 1 & 2, Groups B†, C, D
Cl. I, Zone 1 & 2, IIB + H2‡
Cl. II, Div. 1, Groups E, F, G
Cl. II, Div. 2, Groups F, G
Cl. III
NEMA/EEMAC 3, 4, 4X‡, 7B†CD, 9EFG, 12

D2L Series:
Cl. I, Div. 2, Groups B†, C, D
Cl. I, Zone 2, IIB + H2†
Cl. II, Div. 2, Groups F, G
Cl. III
NEMA/EEMAC: 3, 4, 4X‡, 7B†CD, 12

1A



This corrosion-resistant Type 4X breather and drain comes standard with all PowerPlus panelboards. This permits all models to maintain their Type 4 (Type 4X with suffix S752) rating while utilizing a breather/drain solution to drain internal condensation while protecting against ingress of rain and hose water.

PowerPlus D2L and EPL panels are available with GFI and/or EPD breakers. This 21-position electrical test circuit allows for testing of GFI, EPD, or a combination of both in one panel. EPLDN panels are available with up to 42 GFI or EPD circuits with 225 amp main breaker.

PowerPlus panels come standard with a high-quality silver-plated copper buss system. This provides high-efficiency current flow between the main feed and branch breakers.

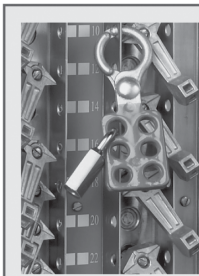
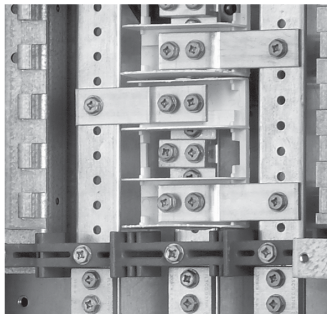

Each branch and main breaker handle is provided with lockout/tagout capability, which complies with OSHA lockout/tagout requirements for safety. This allows for locking in the ON or OFF position for standard maintenance checks.

Spring-loaded, quick-release, captive stainless steel cover bolts come standard. This design prevents damage to the flat joint flame path when opening and closing the cover while providing visual identification of bolt engagement.

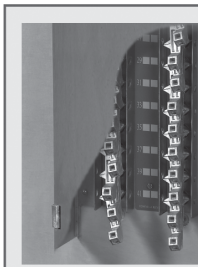

PowerPlus panels are available with an optional hinged stainless steel ice/dust shield. This ice shield solution prevents ice and snow build-up on breaker handles to allow for proper handle function in cold/wet climate applications.

Stainless steel hinges are engineered to provide maximum stability and allow the cover to swing fully open. This avoids misalignment of cover to the body of the enclosure and prevents the cover from obstructing interior access.



EPLCN or EXDCN*

*Note: D2D / EXD panels are not available with GFI or EPD circuit breakers or electrical test circuit as standard. Please contact factory if required.

† Group B and IIB + H2 is standard on all PowerPlus panels, but requires special brackets to be installed on breakers to ensure long-term operability of circuit breakers. To order with brackets installed at factory, add suffix -GB. For field installable kit, order EPL-GB-KIT separately.
‡ NEMA 4X rating is available when ordered with suffix S752 or S753.

1A

1A PowerPlus™ Panelboards

Lighting and Heat Tracing EPL Series (Div. 1 & 2) D2L Series (Div. 2)

EPL Series:
Cl. I, Div. 1 & 2, Groups B†, C, D
Cl. I, Zone 1 & 2, IIB + H₂†
Cl. II, Div. 1, Groups E, F, G
Cl. II, Div. 2, Groups F, G
Cl. III
NEMA/EEMAC 3, 4, 4X‡, 7B†CD, 9EFG, 12

D2L Series:
Cl. I, Div. 2, Groups B†, C, D
Cl. I, Zone 2, IIB + H₂†
Cl. II, Div. 2, Groups F, G
Cl. III
NEMA/EEMAC: 3, 4, 4X‡, 7B†CD, 12

Integrated steel lifting eye is mounted on the top side of each PowerPlus panel. This provides a stable lifting position to ensure ease of mounting during the installation process.

PowerPlus cast enclosures are manufactured with an external flange design. This design allows for a wide unobstructed cover opening and provides a completely accessible interior for ease of maintenance and wiring.

Superior self-aligning breaker operators are designed for both field and factory installation. This patent-pending design guarantees proper handle alignment when closing the cover.*

All panels with terminal housings are factory-sealed†† and fully wired for maximum available circuits. This allows PowerPlus models the ability to have additional breakers field-installed while maintaining their factory seal.

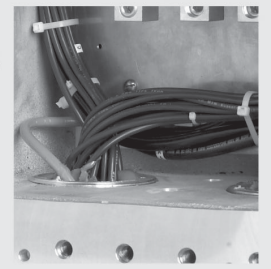

All terminal blocks come fully wired with each contact numbered for easy connecting of branch entries.

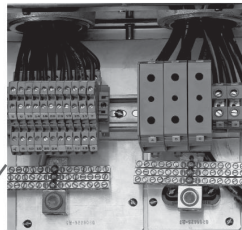

Heavy gauge 316L stainless steel terminal housings are supplied with three removable gland plates to be used with Myers® Hubs. This design allows for the flexibility of factory- or field-drilled openings for hubs.



Stainless steel terminal housings offer a high-integrity gasket, providing a watertight seal to meet enclosure Type 4/CSA ENC. 4/IP65 requirements. This provides superior protection of enclosed wiring against water and corrosion. Cast aluminum enclosures are also gasketed, providing a NEMA 4 watertight seal.

PowerPlus panelboards offer an industrial grade 316L stainless steel terminal housing as standard. This design offers an increased internal volume with a removable front cover for easy access during field installation and maintenance. A cast aluminum terminal housing is standard on EPL and EXD panels and available on D2L and D2D panels.

D2LBS (Inverted) or D2DBS (Inverted)

* Not available in Size F offering. Spring aligning forks are standard on Size F panels.

††EPL*A and EXD*A conduit entries 2" or larger in Class I, Division 1 must be sealed within 18" of enclosure. All alternate feed entries to breaker housing (suffix A) must have an external seal within 18" of enclosure.

† Group B and IIB + H₂ is standard on all PowerPlus panels, but requires special brackets to be installed on breakers to ensure long-term operability of circuit breakers.

To order with brackets installed at factory, add suffix -GB. For field installable kit, order EPL-GB-KIT separately.

‡ NEMA 4X rating is available when ordered with suffix S752 or S753.

PowerPlus™ Panelboards

Lighting and Heat Tracing EPL Series (Div. 1 & 2) D2L Series (Div. 2)

EPL Series:
Cl. I, Div. 1 & 2, Groups B†, C, D
Cl. I, Zone 1 & 2, IIB + H‡
Cl. II, Div. 1, Groups E, F, G
Cl. II, Div. 2, Groups F, G
Cl. III
NEMA/EEMAC 3, 4, 4X‡, 7B†CD, 9EFG, 12

D2L Series:
Cl. I, Div. 2, Groups B†, C, D
Cl. I, Zone 2, IIB + H‡
Cl. II, Div. 2, Groups F, G
Cl. III
NEMA/EEMAC: 3, 4, 4X‡, 7B†CD, 12

1A

Electrical Ratings:

Branch Breakers (120/240VAC Quicklag® Bolt-On)

Trip Ratings:

- 1-, 2-, and 3-pole
- 10, 15, 20, 25, 30, 35, 40, 45, 50 amp (available in all breaker spaces in panel), 55, 60, 70, 80, 90, 100 amp (only 3 breaker spaces available for 55 to 100 amp branch breakers)
- GFI type, 1- and 2-pole (5mA sensitivity) 15, 20, 25, 30, 40 (50 amp - available 2-pole only)
- EPD type, 1- and 2-pole (30mA sensitivity) 15, 20, 25, 30, 40 (50 amp - available 2-pole only)
- HID type, 1- and 2-pole, 15, 20, 25, 30, 35, 40, 50, 60
- Available with GFI, EPD, or a combination of both in one panel with a 21-position electrical test circuit
- Ambient compensated breakers available to +50°C

Main Breaker Trip Ratings:

- 2- or 3-pole
- Size B: 10 to 100 amps
- Size C and D: 10 to 225 amps

Main Lugs:

- Size B, C, and F: 225 amps
- Size D: not available; main breaker only

Options:

To add the following features to the panelboard, add a dash and then the suffix to the Cat. No. When multiple suffixes are needed, add them to the Cat. No. in alpha-numeric order.

Description	Suffix
Space heater.....	R22
Square head plugs on all conduit openings.....	SP
Epoxy powder coat finish, external.....	S752
Epoxy powder coat finish, internal and external.....	S753
Recess head plugs on all conduit openings.....	RP
Stainless steel breaker operator cover (ice shield).....	HG
Group B kit factory installed.....	GB
GFI breakers.....	G
EPD breakers.....	E
HID breakers.....	H
Ambient compensated breakers (50°C).....	V
Lamacoid Nameplate.....	LID

A standard panelboard has conduit openings for power and branch circuits on top.

To order a panelboard with main power feed from the bottom of breaker housing, and branch entries on top (alternate)..... -A**

To order an inverted panelboard with all conduit openings for power and branch circuits on the bottom (inverted)..... -I

To order an inverted panelboard with main power feed on top and bottom (alternate inverted)..... -A-I**

Accessories:

Gland Plates

Field installable gland plates with factory-provided aluminum Myers™ Hubs for the D2L stainless steel terminal housing (one 3-inch hub and 12 branch entry hubs - size dependent upon suffix, each kit includes 3 gland plates, 1 for the top or bottom and 1 for each side):

- 3/4" branch entry hub
- 1" branch entry hub
- 1 1/2" branch entry hub
- Replacement gland plate (no hubs)

Part Number
D2L HUB2 KIT
D2L HUB3 KIT
D2L HUB5 KIT
D2L HUB0 KIT

Circuit Breaker Operator Assemblies:

Operator Assemblies

- D2L/EPL 1-pole or 3-pole breakers
- D2L/EPL 2-pole breakers

Part Number
EPL HDL13
EPL HDL2

Replacement Cover Plugs:

For unused circuit breaker positions (qty. 5):

Plug Kits

- D2L/EPL Sizes B, C, D

Part Number
EPL OP PLG

Kit for Group B

Standard panels less -GB suffix are applicable for Group B, but it is required to install brackets on breakers.

Part Number
add suffix -GB
EPL GB KIT

To order brackets factory installed
For field installable kit

D2L/EPL Stainless Steel Breaker Operator Cover

To protect operators from ice build-up for all

- D2L/EPL PowerPlus panels:
- Kit for Size B panel
- Kit for Size C and D panel

Part Number
EPL-HG24-KIT
EPL HG42-KIT

Space Heater Kit

D2L/EPL PowerPlus Panels

EPL R22 KIT

Terminal Housing Mounting Plate Kit:

To adapt depth of terminal housing to same depth as breaker enclosure ***

Panel Types / Sizes

- D2L/EPL Sizes B, C, D
- D2L Sizes B, C, D

Part Number	Terminal Housing
EPLA-MTG-KIT	Aluminum
D2LS-MTG-KIT	Stainless

† Group B and IIB + H: is standard on all PowerPlus panels, but requires special brackets to be installed on breakers to ensure long-term operability of circuit breakers. To order with brackets installed at factory, add suffix -GB. For field installable kit, order EPL-GB-KIT separately.

‡ NEMA 4X rating is available when ordered with suffix S752 or S753.

** Not available in D2L/EPL Size D panels.

*** The weight of the panel is sufficiently supported by mounting of breaker enclosure.

Crouse-Hinds

by E.T.N

1A PowerPlus™ Panelboards

Lighting and Heat Tracing EPL Series (Div. 1 & 2) D2L Series (Div. 2)

EPL Series:
Cl. I, Div. 1 & 2, Groups B†, C, D
Cl. I, Zone 1 & 2, IIB + H₂†
Cl. II, Div. 1, Groups E, F, G
Cl. II, Div. 2, Groups F, G
Cl. III
NEMA/EEMAC 3, 4, 4X‡, 7B†CD, 9EFG, 12 12

D2L Series:
Cl. I, Div. 2, Groups B†, C, D
Cl. I, Zone 2, IIB + H₂†
Cl. II, Div. 2, Groups F, G
Cl. III
NEMA/EEMAC: 3, 4, 4X‡, 7B†CD,

Table A – Panel Capacity

Maximum Number of Breaker Spaces:

Panel Size	Max. No. of Branch Circuit Breaker Spaces			Available Main Breaker Ampacity	Available With GFI, EPD Branch Protection
	With Main Lug Only	With Main Breaker			
		2-pole	3-pole		
B	24	22	21	Up to 100■	Yes
C§	42	40	39	Up to 100■	Yes
		36	36	110 to 225⊕	Yes
D	N/A	42	42	Up to 225⊕	Yes

Table B – To Size Panels with GFI or EPD Branch Breakers

Maximum Number of GFI or EPD Breakers

Panel Size with Main Lug or Main Breaker	Single-Pole	Two-Pole
B	21	12 (10 with 3-pole MCB, 11 with 2-pole MCB)
C	21	14
D	EPLDN only - can go up to 42 GFI or EPD circuits. EPLDN will accommodate up to 225 amp main breaker.	

Each factory-sealed panel is equipped with 42 load wires for GFI/EPD breakers and any combination with standard branch breakers. Determine the total number of load wires required to complete your panel. You may not exceed 42 load wires.

	Load Wires Required
Single-pole breaker	1
Single-pole GFI (or EPD) breaker	2
Two-pole breaker	2
Two-pole GFI (or EPD) breaker	3
Three-pole breaker	3
Maximum Total: 42 load wires (factory sealed)	
Maximum Total: 84 load wires (non-factory sealed)	

EPLDN Panels

† Group B and IIB + H₂ is standard on all PowerPlus panels, but requires special brackets to be installed on breakers to ensure long-term operability of circuit breakers. To order with brackets installed at factory, add suffix -GB. For field installable kit, order EPL-GB-KIT separately.

‡ NEMA 4X rating is available when ordered with suffix S752 or S753.

§ All size B and size C panels with main breaker rated up to 100 amps use a back-fed branch breaker. All size D and size C panels with main breaker rated from 110 amps to 225 amps have a dedicated location for main breaker. Size C ordered with suffix 2M00 or 3M00 are provided with 36 branch circuits for maximum breaker ampacity.

⊕ Main breakers are mounted external to chassis.

■ Main breakers are chassis mounted and back-fed.

PowerPlus™ Panelboards

Lighting and Heat Tracing EPL Series (Div. 1 & 2) D2L Series (Div. 2)

EPL Series:
Cl. I, Div. 1 & 2, Groups B†, C, D
Cl. I, Zone 1 & 2, IIB + H₂†
Cl. II, Div. 1, Groups E, F, G
Cl. II, Div. 2, Groups F, G
Cl. III
NEMA/EEMAC 3, 4, 4X‡, 7B†CD, 9EFG, 12

D2L Series:
Cl. I, Div. 2, Groups B†, C, D
Cl. I, Zone 2, IIB + H₂†
Cl. II, Div. 2, Groups F, G
Cl. III
NEMA/EEMAC: 3, 4, 4X‡, 7B†CD, 12

1A

Lighting Panelboard Catalog Number Example

Example:

Class I, Division 2 / Zone 2, Group B panel with:

- 240VAC lighting panelboard
- (28) single-pole 20 amp branch breakers
- (1) single-pole 15 amp branch GFI breaker
- 225 amp 3-pole main circuit breaker

Example would be ordered as:

D2L C S 3 30G * 28 1 20 * 01 1 15G - 3 M 225 -GB

- Select panel type _____
D2L = Div. 2 / Zone 2 Panelboard
EPL = Div. 1 & 2 / Zone 1 & 2 Panelboard
- Select size of enclosure _____
B = 24 circuit panel
C = 42 circuit panel (36 circuit panel with main breaker greater than 100 amps)
D = 42 circuit panel
- Select terminal enclosure material type _____
Premium Solution
S = stainless steel terminal housing (Div. 2 / Zone 2 panels only)
A = cast aluminum terminal housing
Value Solution
N = no terminal housing (non-factory-sealed - Div. 1 & 2 / Zone 1 & 2)
- Select panel phase _____
1 = single-phase electrical system
3 = three-phase electrical system
- Select breaker spaces _____
1-pole breaker = 1 breaker space
2-pole breaker = 2 breaker spaces
3-pole breaker = 3 breaker spaces

Example:
(28) 1-pole 20 amp breakers = 28 spaces
+ (1) 1-pole 15 amp GFI breaker = 1 spaces
Total breaker spaces = 29
If odd, round up to even = 30

Note: GFI and EPD each require 1 additional load wire per breaker.
Factory sealed PowerPlus panels offer a maximum of 42 load wires.
For requirements greater than 42, consider non-factory sealed PowerPlus panels.
- Insert asterisk (*) before each branch breaker series _____
- Quantity of alike branch breakers _____
- Branch breaker pole rating _____
1 = single-pole breaker
2 = 2-pole breaker
3 = 3-pole breaker
- Branch breaker ampere rating (numerical value represents ampere rating) _____
20 = 20 amps
- Insert asterisk (*) before each branch breaker series _____
- Quantity of alike branch breakers _____
- Branch breaker pole rating (see #8 above) _____
- Branch breaker ampere rating _____
15 = 15 amps
G = GFI breakers
15G = GFI with 15 amps
- Dash indicates that main breaker follows _____
- Main breaker number of poles _____

18. Group B Option
17. Indicates main breaker amperage rating
16. M indicates main breaker

† Group B and IIB + H₂ is standard on all PowerPlus panels, but requires special brackets to be installed on breakers to ensure long-term operability of circuit breakers. To order with brackets installed at factory, add suffix -GB. For field installable kit, order EPL-GB-KIT separately.
‡ NEMA 4X rating is available when ordered with suffix S752 or S753.

Crouse-Hinds

by **E.T.N**

www.crouse-hinds.com US: 1-866-764-5454 CAN: 1-800-265-0502 Copyright© 2013 Eaton's Crouse-Hinds Business



1A PowerPlus™ Panelboards

Lighting and Heat Tracing EPL Series (Div. 1 & 2) D2L Series (Div. 2)

EPL Series:
Cl. I, Div. 1 & 2, Groups B†, C, D
Cl. I, Zone 1 & 2, IIB + H₂‡
Cl. II, Div. 1, Groups E, F, G
Cl. II, Div. 2, Groups F, G
Cl. III
NEMA/EEMAC 3, 4, 4X‡, 7B†CD, 9EFG, 12

D2L Series:
Cl. I, Div. 2, Groups B†, C, D
Cl. I, Zone 2, IIB + H₂†
Cl. II, Div. 2, Groups F, G
Cl. III
NEMA/EEMAC: 3, 4, 4X‡, 7B†CD, 12

Dimensions Size B Panel* (With Stainless Steel Terminal Housing)

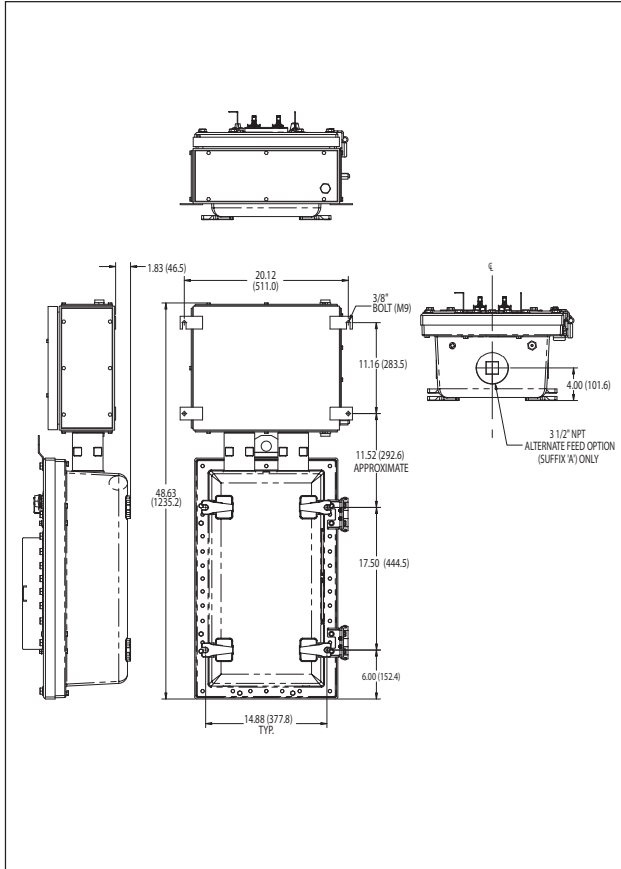

Size C and D Panel* (With Cast Terminal Housing)

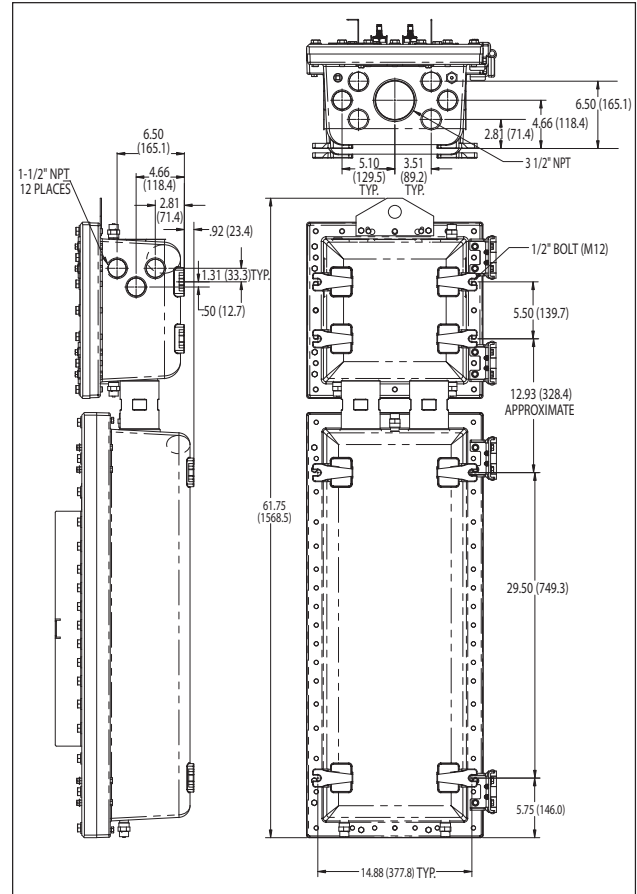

† Group B and IIB + H₂ is standard on all PowerPlus panels, but requires special brackets to be installed on breakers to ensure long-term operability of circuit breakers. To order with brackets installed at factory, add suffix -GB. For field installable kit, order EPL-GB-KIT separately.

‡ NEMA 4X rating is available when ordered with suffix S752 or S753.

*Stainless steel and cast aluminum terminal housing for Sizes B, C, and D are the same. Note: Value series non-factory-sealed EPL*N panel dimensions are the breaker housing only and use standard entries shown on cast terminal housing.