



## SECURHASP II®

### Product Data Sheet

Brooks' SecurHasp II offers improved meter security with a tamper-indicating channel in the seal body for visual indication of tampering.

## APPLICATIONS

The Brooks' SecurHasp II is ideal for sealing meter socket covers and can add an extra level of security when used in conjunction with locking rings and other locking accessories.

## FEATURES

- Polypropylene body with UV inhibitors extends product life and protects against fading.
- 0.047" Wire Hasp is available in Galvanized or Stainless Steel.
- Tamper-indicating channel allows metal hasp to protrude from the seal body if tampering has occurred.
- Standard and Secure Hasp configurations available.
- Heat Stamped or Cold Stamped Name, Logo or 7-digit Serial Numbers in black or white lettering.
- 17 Body Color Options.



PLASTIC PADLOCK COLOR CHART		1 RED	2 GREEN	3 LT BLUE
4 ORANGE	5 GRAY	6 YELLOW	8 BLACK	10 WHITE
12 PURPLE	13 DK BLUE	14 DK GREEN	18 BROWN	19 LIME
20 ROSE	21 RUST	24 TRANS-LUCENT	27 CLEAR	

# DIMENSIONS

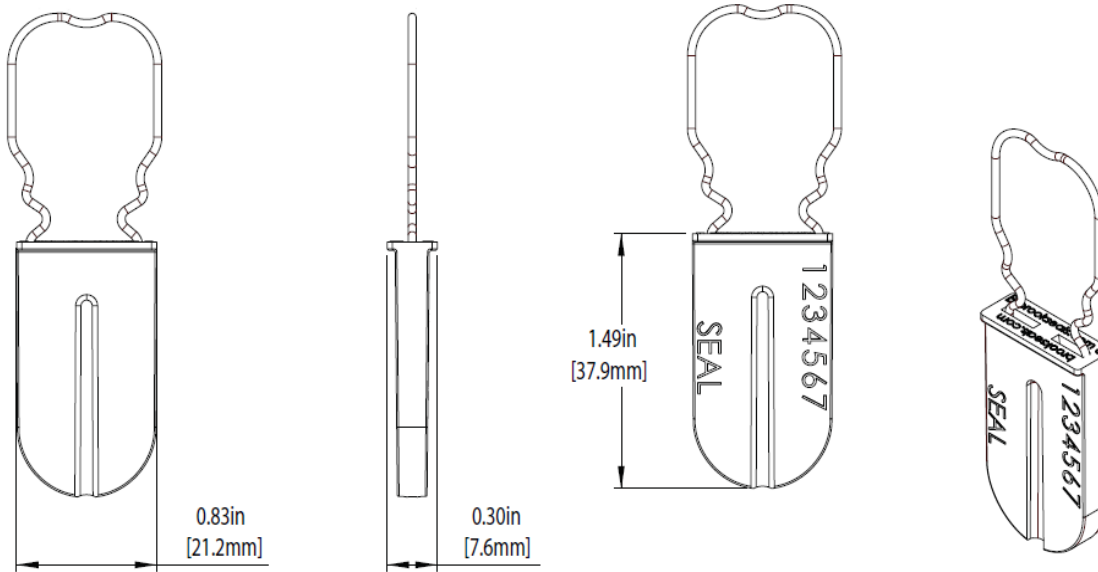

## MODEL NUMBERS

- 6250000-X** .047" Galvanized Secure Hasp, Round Body
- 6250030-X** .047" Galvanized Regular Hasp, Round Body
- 6259000-X** .047" Stainless Secure Hasp, Round Body
- 6259008-X** .047" Stainless Regular Hasp, Angle Cut, Round Body
- 6250600-X** .047" Galvanized Secure Hasp, Square Body
- 6250630-X** .047" Galvanized Regular Hasp, Square Body
- 6259600-X** .047" Stainless Secure Hasp, Square Body
- 6259608-X** .047" Stainless Regular Hasp, Angle Cut, Square Body

*Note: X denotes color selection*

## PACKAGING

**Standard Packaging:**  
1,000/Box—5,000/Carton

**Carton Dimensions:**  
41" x 14" x 11"  
(102.5cm x 35cm x 28cm)

**Carton Weight:**  
Gross: 54 lbs (24kg)

**Special Packaging:**  
100/Box—2,500/Carton  
100/Wire—1,000/Box—5,000/Carton  
100/Wire—1,000/Box—2,000/Carton