

# AS-i Metal Enclosed DOL Starters

Class 8340

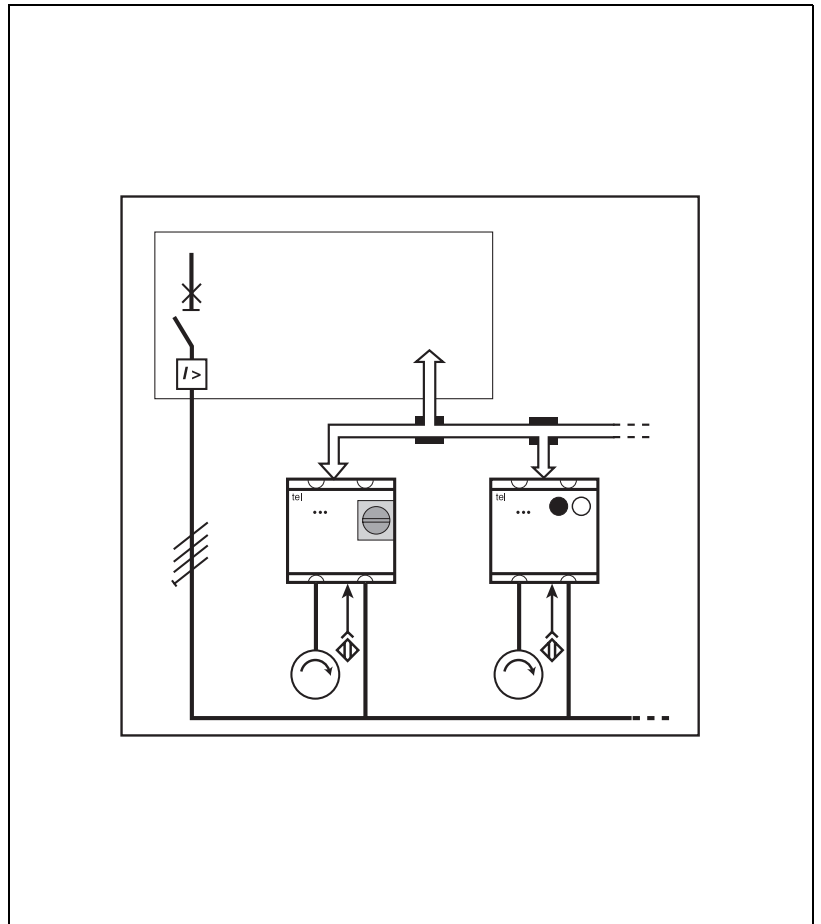

Schneider Electric Brands

## CONTENTS

Description	Page
Product Configuration and Introduction .....	2-7
Selection .....	8-9
General Specifications .....	9-11
Electrical Specifications and Data Bus Information Exchange .....	11-14
Dimensions .....	15-22
Wiring Diagrams .....	23



**SQUARE D**  
Schneider Electric

# AS-i Metal Enclosed DOL Starters Decentralized Systems

## INTRODUCTION TO AS-I DIRECT-ON-LINE (DOL) STARTERS

### Decentralization of Machine Starters

These pre-assembled, ready-to-use, enclosed starters communicate with and are controlled by the AS-i bus. They are designed for building decentralized electrical installations, that is, the starters are installed adjacent to the associated motor. This decentralization of the starters provides obvious advantages for power distribution to motors not grouped together—for example, motors driving a conveyor system.

### Centralized system

In this example, cabling the motor equipment requires approximately 1640 ft (500 m) of 4 x 16 AWG (4 x 1.5 mm<sup>2</sup>) cable.

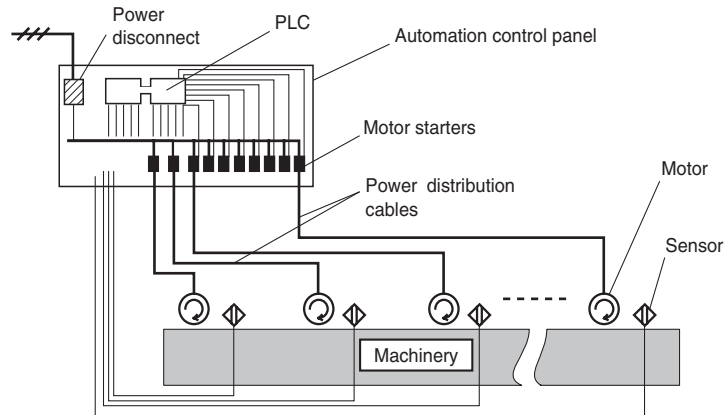

### Decentralized system

The decentralized system uses only 260 ft (80 m) of 4 x 12 AWG (4 x 4 mm<sup>2</sup>) cable. This results in cost savings in terms of installation labor as well as cable and cable ducts. This installation is also more flexible—it is easier to add a motor.

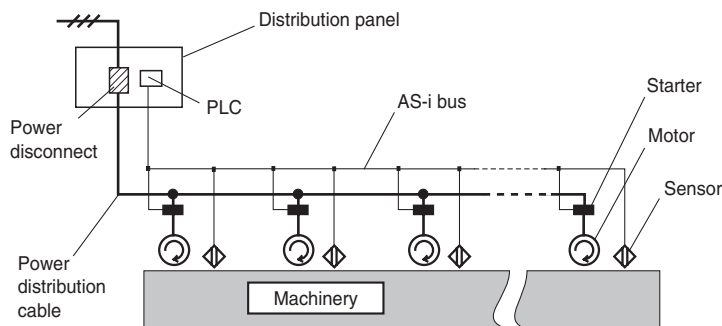

Power can be distributed either by prefabricated trunking or by cable.

These starters integrate all the functions necessary for the management of motors (control, protection, isolation, etc.) and contain:

- a thermal-magnetic protector combined with a local operator interface for manual disconnect
- a low-consumption contactor (non-reversing) or contactor pair (reversing)
- an electronic control device

Although designed primarily for use with three-phase AC motors, AS-i DOL starters can also be used with single-phase or DC motors. For these applications, the three phases of the internal thermal-magnetic protector is wired in series (each phase sensing the same current) to avoid tripping due to a perceived phase failure.

# AS-i Metal Enclosed DOL Starters

## Important Information

### Important Application Information for AS-i DOL Starters

AS-i based direct-on-line (DOL) starters combine the following components into one package:

- A GV2 manual starter containing a manual disconnect, an instantaneous magnetic trip mechanism, and a Class 10 ambient-compensated, bi-metallic thermal overload relay
- An appropriately sized K-line contactor
- An AS-i communications interface board
- Related plugs and connectors for bus and power and for auxiliary inputs such as sensors or limit switches

### An Important User Consideration when Applying DOL Starters:

Users must provide in their application any appropriate branch circuit protection (circuit breaker, fusing, etc.) to meet all local and national codes, in particular, the National Electrical Code (NEC) or Canadian Electrical Code (CEC).

The instantaneous magnetic trip mechanism in the GV2 manual starter is a high fault current trip mechanism, particularly for short circuit conditions in a motor circuit. *The magnetic trip mechanism is **not** a circuit breaker as defined in NEC section 430.* It is up to the user to provide appropriate branch circuit protection to meet all NEC, CEC, or local electrical code requirements. This step is also necessary for meeting Type 2 coordination in motor branch circuits.

For additional information on Type 2 coordination, refer to Square D product data bulletin 0140PD9202, *Understanding Type 2 Coordinated Protection in Motor Branch Circuits.*

### Internal View of the Starter

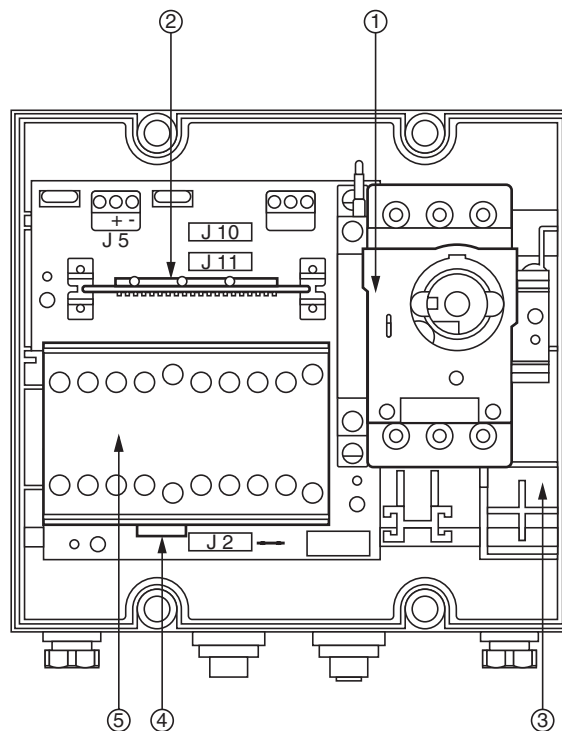

1. GV2-M or GV2-P manual motor starter
2. Electronic communication card
3. Earth (ground) terminal
4. Relay
5. Contactor used (see table)

	LF•M•00D•••U LF•M•16D•••U	All others
non-reversing starters	LP4-K12015BW3	LP4-K09015BW3
reversing starters	LP5-K12015BW3	LP5-K09015BW



## AS-i Metal Enclosed DOL Starters Features and Options

### Connection through Plug-In Connectors, A74 Option Shown

Starter with Rotary Control Knob

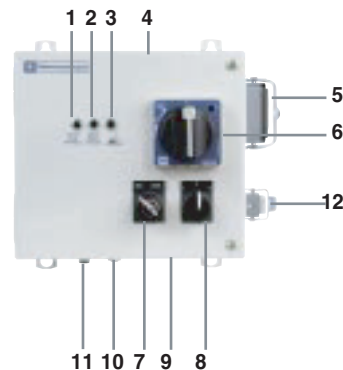

Starter with Pushbutton Control

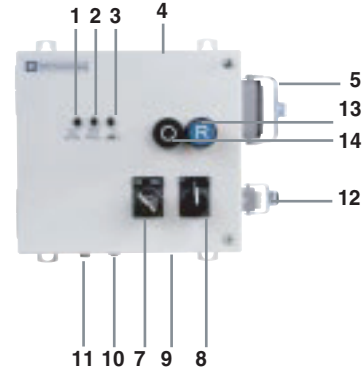

Cable gland connection is provided as standard, refer to page 19.

1. Yellow LED:
  - Steady on when the motor is running
2. Red LED:
  - Flashing when there is a motor fault (overload or short-circuit) or internal starter fault
  - Steady on when there is a data exchange fault
3. Green LED:
  - Steady on when power is available on the AS-i bus
  - Flashing when data intended for the starter is received via the bus
4. Knock-outs for cable glands (supplied) for the connector cable (if any) of an auxiliary power supply unit (A79 option only)
5. Power supply daisy chaining male connector (A74 option)
6. Three-position rotary disconnect-switch control knob.
  - O: Opened manually
  - I: Closed
  - Trip: Tripped
7. Key-operated bus/Local switch (A79 option)
8. Reversing starter (LF2):
  - Three-position selector switch with center spring-loaded position
  - Functional assignment:
    - Position 1 forward
    - Position 0 off
    - Position 2 reverse (A79 option)
- Non-reversing starter (LF1):
  - Push buttons
  - Functional assignment: Pulsed run (jogging)
9. Precut for auxiliary relay output cable gland (not supplied)
10. Female M12 connector for sensor connection (not supplied with dust cap)
11. Male M12 connector for AS-i bus and auxiliary power supply unit (if any) connection
12. Motor power supply female connector (A74 option)
13. Reset pushbutton switch
14. Off pushbutton switch

## Motor Control and Protection

Starters with a **rotary control knob** provide the following functions:

- Load break disconnect switch with padlockable control knob
- IP55 degree of protection, double insulation
- Opening of the enclosure is mechanically inhibited when the starter is switched on or when in the off position and padlocked.

Starters with **pushbutton control** provide the following functions:

- Pushbutton resetting of the protection device
- Pushbutton stop
- IP55 degree of protection, double insulation

## Local Controls

On standard DOL starters, stop and reset functions are possible from the front of the enclosure. The stop command is achieved by actuating the internal manual starter button, which provides the isolation function. Depending on the type of starter, the stop command is issued by either:

- a rotary control knob
- a black pushbutton

If an overload occurs, it is possible to reset the internal thermal-magnetic protector after the motor cools down.

Depending on the type of starter, the restart command is issued by either:

- a rotary control knob
- a blue reset pushbutton

## Integral Local/Bus Control (user option A79)

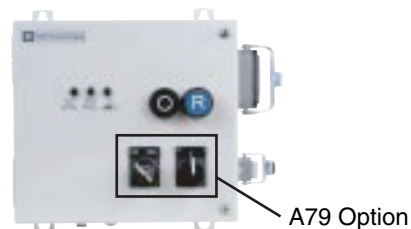

This starter option includes a two-position local/bus key operated selector switch which enables either of the following functions:

- Bus: the PLC controls the motor starter
- Local: the Start/Stop commands override commands from the PLC

It also has:

- For reversing starters (LF2), a three-position, spring return to zero, selector switch:
  - Position 1: starting direction 1 (forward)
  - Position 0: stop
  - Position 2: starting direction 2 (reverse)
- For non-reversing starters (LF1), a pushbutton which performs a jogging operation

# AS-i Metal Enclosed DOL Starters Control

## Pushbutton Station Control

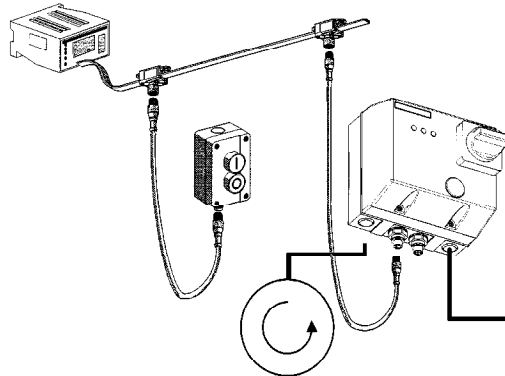

To achieve manual local start control from a pushbutton control station connected to the AS-i bus, use AS-i pushbutton control stations, catalog number XALS200• or an equivalent part. These can be found in the AS-i Bus catalog 8340CT0001.

Actuation of the pushbutton is transmitted to the programmable controller (message 1), which passes it on to the starter (message 2).

## Local Signalling

Three LEDs located on the enclosure cover provide visual indication of the operating states. For details, see page 4.

## Important User Information

- This starter features continual self-checking to ensure correct operation.
- This starter **does not** process external safety functions.
- Use only hard-wired, electromechanical emergency stops and machine safety circuits. Electrical codes EN/IEC 60204-1 Section 9.2.5.4 and applicable NEC and CEC standards do not currently allow these functions via a network (i.e. the AS-i bus).
- An independent safety device is required to re-establish the supply voltage to the starter after a supply failure.
- The starter control operator (rotary knob or pushbutton) does not act as an emergency stop when the machine incorporates other actuators. The control operators are black to conform with the standard EN 60204 Section 10.2.1
- Starters with rotary control knobs are not emergency stops—they are padlockable in the on position.

## Loss of Control

When communication is interrupted, the PLC no longer controls the starter. The factory default configuration is set to stop the motor. However, the starter can be configured via the AS-i bus to one of the following default conditions:

- set to stop the motor (applications: potentially dangerous movements)
- set to start the motor in direction 1 (applications: extraction fans, pumps)
- set the motor to run at the setting immediately before the loss of control (application: suction grippers)

# AS-i Metal Enclosed DOL Starters With Relays or Sensors

## Output Control Relay

An output control relay is used to control a lamp, a solenoid valve, and so forth via the AS-i bus using a 24 Vdc, 1 A relay with a single pole, double throw (SPDT), single break contact, see page 21.

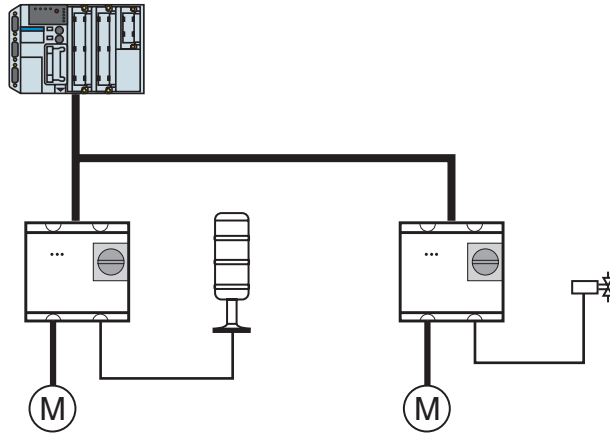

## Starters with a Sensor Connected

Two 3-wire type PNP sensors (50 mA max.) or two 2-wire limit switches can be connected directly to the starter. The information supplied by the sensor/limit switch is returned on the AS-i bus.

Alternatively, the sensor signal can be processed locally for establishing a reflex motor stop. Selection of this feature is made by DIP switches.

## Reflex Stop

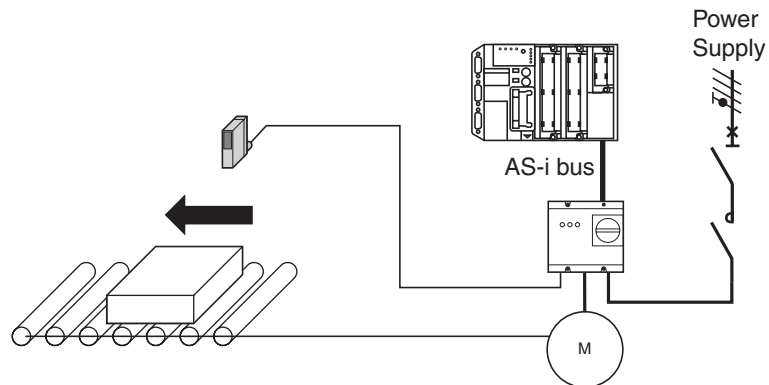

A reflex stop occurs whenever the first sensor detects a component. When a new start command is received via the AS-i bus, the motor restarts but stops again following the next detection. In the case of a reversing starter, the detector stops the motor regardless of its running direction.

# AS-i Metal Enclosed DOL Starters

## Catalog Number Structure

### SELECTION

#### Catalog Number Structure

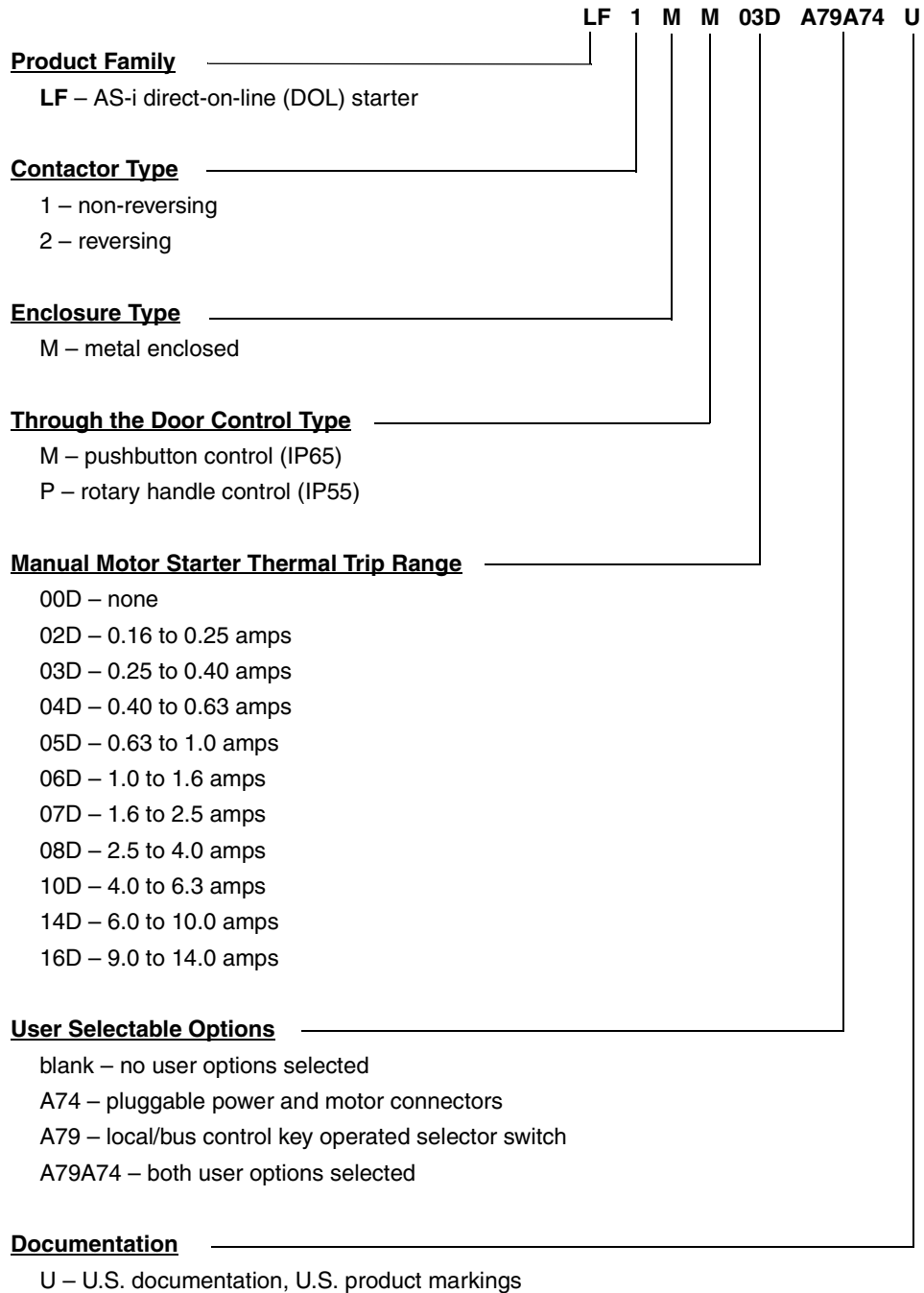



## AS-i Metal Enclosed DOL Starters Starter Selection and Ratings

### Starter Selection

Adjustable Thermal Trip Range (Amps)	Non-Reversing, Pushbutton Control	Non-Reversing, Rotary Control	Reversing, Pushbutton Control	Reversing, Rotary Control
0.16 to 0.25	LF1MM02D(1)U	LF1MP02D(1)U	LF2MM02D(1)U	LF2MP02D(1)U
0.25 to 0.40	LF1MM03D(1)U	LF1MP03D(1)U	LF2MM03D(1)U	LF2MP03D(1)U
0.40 to 0.63	LF1MM04D(1)U	LF1MP04D(1)U	LF2MM04D(1)U	LF2MP04D(1)U
0.63 to 1.0	LF1MM05D(1)U	LF1MP05D(1)U	LF2MM05D(1)U	LF2MP05D(1)U
1.0 to 1.6	LF1MM06D(1)U	LF1MP06D(1)U	LF2MM06D(1)U	LF2MP06D(1)U
1.6 to 2.5	LF1MM07D(1)U	LF1MP07D(1)U	LF2MM07D(1)U	LF2MP07D(1)U
2.5 to 4.0	LF1MM08D(1)U	LF1MP08D(1)U	LF2MM08D(1)U	LF2MP08D(1)U
4.0 to 6.3	LF1MM10D(1)U	LF1MP10D(1)U	LF2MM10D(1)U	LF2MP10D(1)U
6.0 to 10.0	LF1MM14D(1)U	LF1MP14D(1)U	LF2MM14D(1)U	LF2MP14D(1)U
9.0 to 14.0	LF1MM16D(1)U	LF1MP16D(1)U	LF2MM16D(1)U	LF2MP16D(1)U

(1) Insert the appropriate suffix from the following user options into the catalog number above:

User Option Suffix	Description
<i>blank</i>	No user options selected.
A74	Pluggable power and motor connectors.
A79	Local / bus control key operated selector switch.
A79A74	Both user options as described above.

Examples of correct catalog number sequences:

- LF1MM03DU      • LF1MM03DA79U
- LF1MM03DA74U   • LF1MM03DA79A74U

### GENERAL SPECIFICATIONS

#### Ratings

Catalog Number	Adjustable Thermal Trip Range (A)	Maximum Horsepower Ratings (Hp)						Standard Power Ratings (kW) Three Phase, 50/60 Hz, AC-3	
		Single Phase		Three Phase				220/230 Vac	400/415 Vac
		115 Vac	230 Vac	200 Vac	230 Vac	480 Vac	575 Vac		
LF*M*02D***U	0.16 to 0.25							—	0.06
LF*M*03D***U	0.25 to 0.40							0.06	0.09
LF*M*04D***U	0.40 to 0.63							—	0.12 / 0.18
LF*M*05D***U	0.63 to 1.0					1/2	1/2	0.09 / 0.12	0.25
LF*M*06D***U	1.0 to 1.6		1/10			3/4	1	0.18 / 0.25	0.37 / 0.55
LF*M*07D***U	1.6 to 2.5		1/6	1/2	1/2	1	1-1/2	0.37	0.75
LF*M*08D***U	2.5 to 4.0	1/8	1/3	3/4	1	2	3	0.55 / 0.75	1.1 / 1.5
LF*M*10D***U	4.0 to 6.3	1/4	1/2	1-1/2	1-1/2	3	5	1.1	2.2
LF*M*14D***U	6.0 to 10.0	1/2	1-1/2	2	3	5	5	1.5	3 / 4
LF*M*16D***U	9.0 to 14.0	3/4	2	3	3	7.5	10	2.2 / 3	5.5



# AS-i Metal Enclosed DOL Starters

## Environmental Specifications

### Environment

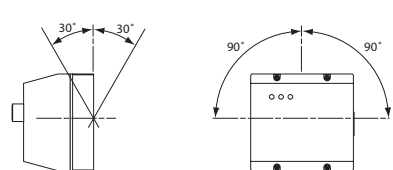
<b>Conforming to Standards</b>		IEC 60204-1, EN 60204-1, IEC 60974-4-1, EN 60974-4-1
<b>Product Certifications</b>	Pending	AS-i
<b>Protective Treatment</b>	Standard version	"TC", see IEC style contactors and starters in the DigestPlus Selector on the Square D website, <a href="http://www.SquareD.com">www.SquareD.com</a>
<b>Degree of Protection</b> conforming to IEC 60529	Starters with rotary control knob	IP 55
	Starters with pushbutton control	IP 55
<b>Ambient Air Temperature</b> conforming to IEC 60439-1	Storage	-40 °F to +176 °F (-40 °C to +80 °C)
	Operation	+23 °F to +104 °F (-5 °C to +40 °C)
<b>Maximum Operating Altitude</b>	Without derating	6562 ft (2000 m)
<b>Operating Position</b> without derating	In relation to normal vertical mounting plane	
<b>Flame Resistance of Equipment</b>	Conforming to IEC 60695-2-1	1760 °F (960 °C)
<b>Shock Resistance</b> (semi-sinusoidal, 11 ms) conforming to IEC 60068-2-27	Contacteur poles open	10 g
	Contacteur poles closed	15 g
<b>Vibration Resistance 5 to 150 Hz</b> conforming to IEC 60068-2-6	Contacteur poles open	2 g
	Contacteur poles closed	4 g
<b>Safety Separation of Circuits</b>	Conforming to VDE 0106 and IEC 60536	SELV (Safety Extra Low Voltage), up to 400 V
<b>Immunity to Non-Dissipating Shockwave (Uimp)</b>	Conforming to IEC 60947-4-1	6 kV: power 2.5 kV: AS-i, 24 V, and sensor
<b>Chemical Resistance</b>		Avoid the following chemicals coming into contact with the enclosure: strong bases (various detergents), aromatic hydrocarbons, alcohol, chlorine solvents, ketones.

### Electromagnetic Compatibility

<b>Immunity to Electrostatic Discharge</b>	Conforming to IEC 61000-4-2 EN 61000-4-2	8 kV: in air (level 3) 4 kV: in indirect mode (level 2)
<b>Immunity to Fast Transient Currents</b>	Conforming to IEC 61000-4-4 EN 61000-4-4	2 kV: power, AS-i, 24 V, and sensor (level 3)
<b>Immunity to Dissipated Surge</b>	Conforming to IEC 61000-4-5 EN 61000-4-5	4 kV/2 kV: power (level 4) 2 kV/0.5 kV: AS-i, 24 V, and sensor (level 2)
<b>Immunity to Conducted Radio-Frequency Disturbance</b>	Conforming to IEC 61000-4-6 ENV 50 141	10 V/m
<b>Immunity to Radiated Radio-Frequency Disturbance</b>	Conforming to IEC 61000-4-3 ENV 50 140 and ENV 50 204 (GSM)	10 V/m
<b>Radio-Conducted and Radio-Radiated Rejection</b>	ENV 55 011/CISPR11 (G1)	Class B

### UL/CSA:



File: E164862  
CCN: NLDX



File: 170M  
CCN: NLDX.7



# AS-i Metal Enclosed DOL Starters Cabling and Electrical Specifications

## Cabling

Type of Starter		LF1		LF2		
		Minimum	Maximum	Minimum	Maximum	
Power Supply Cabling	Screw clamp terminals	Solid cable	1 x16 AWG (1 x 1.5 mm <sup>2</sup> )	2 x10 AWG (2 x 6 mm <sup>2</sup> )	1 x16 AWG (1 x 1.5 mm <sup>2</sup> )	2 x10 AWG (2 x 6 mm <sup>2</sup> )
		Flexible cable without cable end	1 x16 AWG (1 x 1.5 mm <sup>2</sup> )	2 x10 AWG (2 x 6 mm <sup>2</sup> )	1 x16 AWG (1 x 1.5 mm <sup>2</sup> )	2 x10 AWG (2 x 6 mm <sup>2</sup> )
		Flexible cable with cable end	1 x16 AWG (1 x 1.5 mm <sup>2</sup> )	2 x12 AWG (2 x 4 mm <sup>2</sup> )	1 x16 AWG (1 x 1.5 mm <sup>2</sup> )	2 x12 AWG (2 x 4 mm <sup>2</sup> )
		Tightening torque (1)	15 lb-in. (1.7 N•m)	15 lb-in. (1.7 N•m)	15 lb-in. (1.7 N•m)	15 lb-in. (1.7 N•m)
	Cable gland	Clamping capacity	0.39 in. (10 mm)	0.59 in. (15 mm)	0.39 in. (10 mm)	0.59 in. (15 mm)
Motor Cabling	Screw clamp terminals		Minimum	Maximum	Minimum	Maximum
		Solid cable	1 x16 AWG (1 x 1.5 mm <sup>2</sup> )	2 x12 AWG (2 x 4 mm <sup>2</sup> )	1 x16 AWG (1 x 1.5 mm <sup>2</sup> )	1 x12 AWG (1 x 4 mm <sup>2</sup> )
		Flexible cable without cable end	1 x16 AWG (1 x 1.5 mm <sup>2</sup> )	2 x12 AWG (2 x 4 mm <sup>2</sup> )	1 x16 AWG (1 x 1.5 mm <sup>2</sup> )	1 x12 AWG (1 x 4 mm <sup>2</sup> )
		Flexible cable with cable end	1 x16 AWG (1 x 1.5 mm <sup>2</sup> )	1 x16 AWG + 1 x14 AWG (1 x 1.5 mm <sup>2</sup> ) + (1 x 2.5 mm <sup>2</sup> )	1 x16 AWG (1 x 1.5 mm <sup>2</sup> )	1 x14 AWG (1 x 2.5 mm <sup>2</sup> )
	Tightening torque (1)	7.1 lb-in. (0.8 N•m)	7.1 lb-in. (0.8 N•m)	7.1 lb-in. (0.8 N•m)	7.1 lb-in. (0.8 N•m)	
Cable gland	Clamping capacity	0.39 in. (10 mm)	0.59 in. (15 mm)	0.39 in. (10 mm)	0.59 in. (15 mm)	
Auxiliary 24 V Supply and Output Control Relay Cabling	Screw clamp terminals		Minimum	Maximum	Minimum	Maximum
		Solid cable	22 AWG (0.5 mm <sup>2</sup> )	16 AWG (1.5 mm <sup>2</sup> )	22 AWG (0.5 mm <sup>2</sup> )	16 AWG (1.5 mm <sup>2</sup> )
		Flexible cable without cable end	22 AWG (0.5 mm <sup>2</sup> )	16 AWG (1.5 mm <sup>2</sup> )	22 AWG (0.5 mm <sup>2</sup> )	16 AWG (1.5 mm <sup>2</sup> )
		Flexible cable with cable end	22 AWG (0.5 mm <sup>2</sup> )	16 AWG (1.5 mm <sup>2</sup> )	22 AWG (0.5 mm <sup>2</sup> )	16 AWG (1.5 mm <sup>2</sup> )
	Tightening torque (2)	6.2 lb-in. (0.7 N•m)	6.2 lb-in. (0.7 N•m)	6.2 lb-in. (0.7 N•m)	6.2 lb-in. (0.7 N•m)	
Cable gland	Clamping capacity	0.39 in. (10 mm)	0.59 in. (15 mm)	0.39 in. (10 mm)	0.59 in. (15 mm)	

(1) Phillips No. 2 or flat screwdriver  $\varnothing$  5.5.

(2) Flat screwdriver  $\varnothing$  3.5.

## ELECTRICAL SPECIFICATIONS

### Pole Electrical Specifications

Utilization Category	Conforming to IEC 60947-2	A	
	Conforming to IEC 60947-4-1 (motor starter)	AC-3	
Rated Operational Voltage (Ue)	Conforming to IEC 60947	415 V	
Rated Insulation Voltage (Ui)	Conforming to IEC 60947	415 V	
Rated Operational Frequency	Conforming to IEC 60947	50/60 Hz	
Breaking Capacity (Ics and Icu)	Conforming to IEC 60947-2	230/240 V	> 100 kA
		400/415 V	> 100 kA
Phase Failure Sensitivity	Conforming to IEC 60947-4-1 and 7-2-1-5-2	Yes	

### Other Specifications

Starters with Rotary Control Knob	Manual starter/thermal-magnetic protector type GV2P	See the Square D Digest <sup>[1]</sup>
Starters with Pushbutton Control	Manual starter/thermal-magnetic protector type GV2P	See the Square D Digest <sup>[1]</sup>
Non-Reversing Starters	Contactors LP4K0905BW3 or LP4K1205BW3	See the Square D Digest <sup>[1]</sup>
Reversing Starters	Reversing contactor pair LP5K0905BW3 or LP5K1205BW3	See the Square D Digest <sup>[1]</sup>

<sup>[1]</sup> Also see the DigestPlus Selector on the Square D website, [www.SquareD.com](http://www.SquareD.com).



# AS-i Metal Enclosed DOL Starters

## Sensor, Relay, and Current Consumption Specifications

### Sensor Inputs

<b>Cabling</b>		M12
<b>Nominal Input Values</b>	Voltage	24 Vdc
	Maximum current available per sensor	50 mA
	Sensor supply (including ripple)	19–30 V
<b>Input Value Limits</b>	At state 1	> 12.6 Vdc
		> 4.9 mA
	At state 0	> 5 Vdc
		< 2.1 mA
<b>Input Impedance</b>		> 2 k $\Omega$
<b>Filtering Time</b>	Typical	7 ms
	Maximum	9.8 ms
<b>Maximum Number of Sensors</b>		2
<b>Proximity Sensor Compatibility</b>	2-wire/3-wire	Yes
<b>Isolation with respect to AS-i Bus</b>		None
<b>Input Type</b>		3-wire PNP, 2-wire solid-state, or 2-wire limit switches

### Output Control Relay

<b>Operating Voltage Limit</b>		24 Vac
		24 Vdc
<b>Thermal Current (I<sub>th</sub>) at 104 °F (40 °C)</b>		5 A
<b>Response Time</b>	Latching	< 10 ms
	Unlatching	< 10 ms
<b>Contact Type</b>		C/O (single pole, double throw, single break)
<b>Integral Protection</b>	Against overloads and short-circuits	None; use of a “fast-blow” fuse recommended as required by NEC and other local codes.
	Against DC or AC inductive overvoltages	Protected against transient voltages associated with inductive loads
<b>Isolation</b>	RMS voltage between output and earth or between output and internal logic	1500 Vac, 50/60 Hz, duration 60 s
	Insulation resistance between output terminals and AS-i bus	> 1000 M $\Omega$

### Current Consumption

Type of Starter		Starter Configured for Supply from AS-i Bus		Starter Configured for Supply from an External 24 Vdc Source	
		LF1	LF2	LF1	LF2
From the AS-i bus	De-energized	80 mA	90 mA	80 mA	90 mA
	Inrush	190 mA	200 mA	80 mA	90 mA
	Energized	110 mA	120 mA	80 mA	90 mA
	With sensor	Sensor consumption (50 mA max.) + 15 mA (signal = 1)			
	Relay	25 mA			
From the External 24 Vdc Supply	De-energized	—	—	0	0
	Inrush	—	—	110 mA	110 mA
	Energized	—	—	30 mA	30 mA



## AS-i Metal Enclosed DOL Starters Short Circuit Current

### Maximum RMS Short Circuit Current

Adjustable Thermal Trip Setting Range (amps)	Push Button Control	Max RMS, kA		Rotary Handle Control	Max RMS, kA	
		480 V	600 V		480 V	600 V
0.16–0.25	LF•MM02D•••U	50	30	LF•MP02D•••U	50	30
0.25–0.40	LF•MM03D•••U	50	30	LF•MP03D•••U	50	30
0.40–0.63	LF•MM04D•••U	50	30	LF•MP04D•••U	50	30
0.63–1.0	LF•MM05D•••U	50	30	LF•MP05D•••U	50	30
1.0–1.6	LF•MM06D•••U	50	30	LF•MP06D•••U	50	30
1.6–2.5	LF•MM07D•••U	50	30	LF•MP07D•••U	50	30
2.5–4.0	LF•MM08D•••U	50	30	LF•MP08D•••U	50	30
4.0–6.3	LF•MM10D•••U	50	30	LF•MP10D•••U	50	30
6–10	LF•MM14D•••U	30	30	LF•MP14D•••U	50	30
9–14	LF•MM16D•••U	25	10	LF•MP16D•••U	50	18

The starters are suitable for use on a circuit having an available fault current not exceeding the lesser of the value from the table above and:

- the fuse short circuit current rating when protected by a fuse in a group fusing application
- the circuit breaker short circuit current rating when protected by a circuit breaker in group installation



# AS-i Metal Enclosed DOL Starters

## Data Exchange Consumption

### Data Bus Information Exchange

AS-i profile is 7.D. SW2 is a four slot DIP switch on the AS-i communication board inside the DOL starter.

<b>Input (states)</b>		
Bit value	= 0	= 1
Status D0 (E)	Not ready or fault	Ready
Status D1 (E)	Stopped	Running
<b>If SW2 Position 3 = OFF and SW2 Position 4 = OFF</b>		
Status D2 (E)	Sensor 1 signal absent	Sensor 1 signal present
Status D3 (E)	Sensor 2 signal absent	Sensor 1 signal present
<b>If SW2 Position 3 = ON and SW2 Position 4 = OFF</b>		
Status D2 (E)	No fault	Fault
Status D3 (E)	Sensor 1 signal absent	Sensor 1 signal present
<b>If SW2 Position 3 = OFF and SW2 Position 4 = ON</b>		
Status D2 (E)	Sensor 1 signal absent	Sensor 1 signal present
Status D3 (E)	Command by bus	Local command
<b>If SW2 Position 3 = ON and SW2 Position 4 = ON</b>		
Status D2 (E)	No fault	Fault
Status D3 (E)	Command by bus	Local command
<b>Output (commands)</b>		
Bit value	= 0	= 1
Command D0 (S)	Forward stop	Forward run
Command D1 (S)	Reverse stop (1)	Reverse run (1)
Command D2 (S)	Auxiliary relay disabled	Auxiliary relay enabled
Command D3 (S)	Unused	Unused
<b>Parameters</b>		
Bit value	= 0	= 1 (value by fault)
Parameter P0	Watch dog disabled (Status holding)	Watch dog enabled (Default position)
Parameter P1	Run default position	Stop default position
Parameter P2	Unused	Unused
Parameter P3	Reflex function inhibited	Reflex function enabled

(1) Applicable to LF2 model only.



# AS-i Metal Enclosed DOL Starters Dimensions—Rotary Knob Control

## DIMENSIONS

1 or 2-direction starters with rotary control – Metal enclosure  
With cable gland  
LF●MP●●D

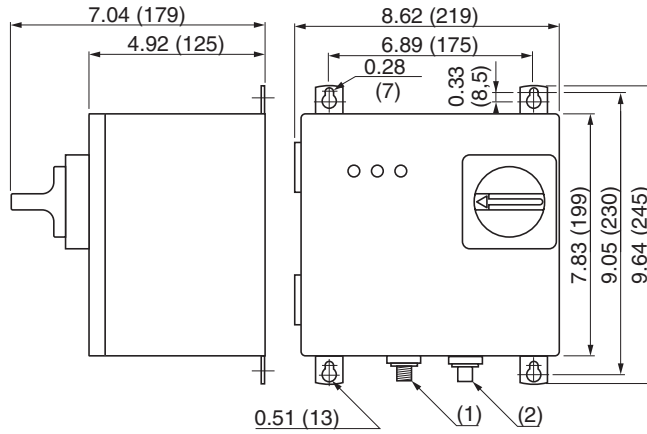

With HARTING plug-in connectors (A74) – Metal enclosure  
LF●MP●●DA74

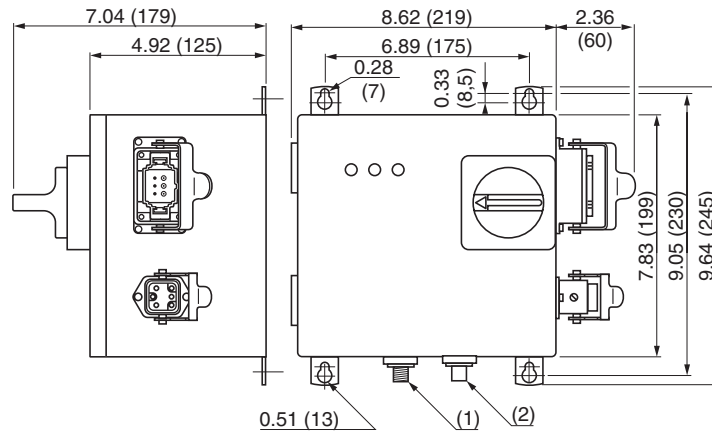

- (1) M12 male connector for connection to the AS-i bus
- (2) M12 female connector for sensor connection

Dim.: in. (mm)



# AS-i Metal Enclosed DOL Starters Dimensions—Rotary Knob Control

1 or 2-direction starters with rotary control – Metal enclosure  
With cable gland  
LF●MP●●DA79

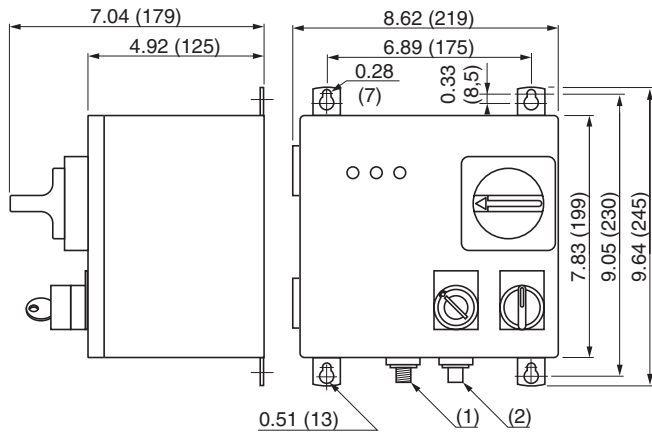

With HARTING plug-in connectors (A74) – Metal enclosure  
LF●MP●●DA79A74

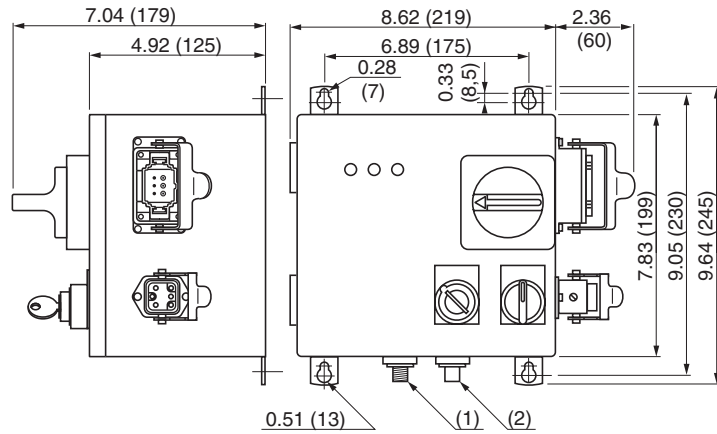

(1) M12 male connector for connection to the AS-i bus  
(2) M12 female connector for sensor connection

Dim.: in. (mm)



## AS-i Metal Enclosed DOL Starters Dimensions—Pushbutton Control

1 or 2-direction starters with pushbutton control – Metal enclosure  
With cable gland  
LF●MM●●D

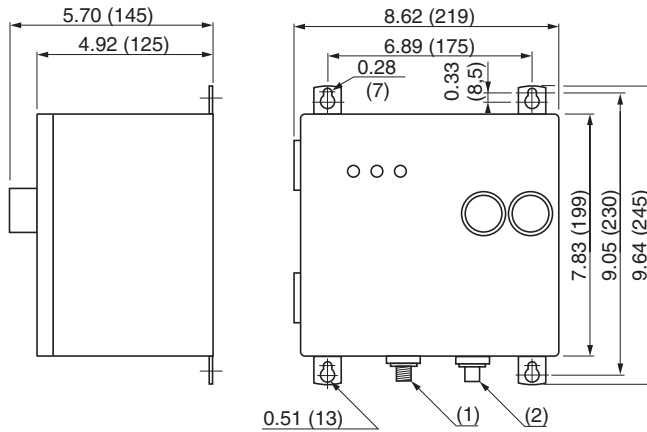

With HARTING plug-in connectors (A74) – Metal enclosure  
LF●MM●●DA74

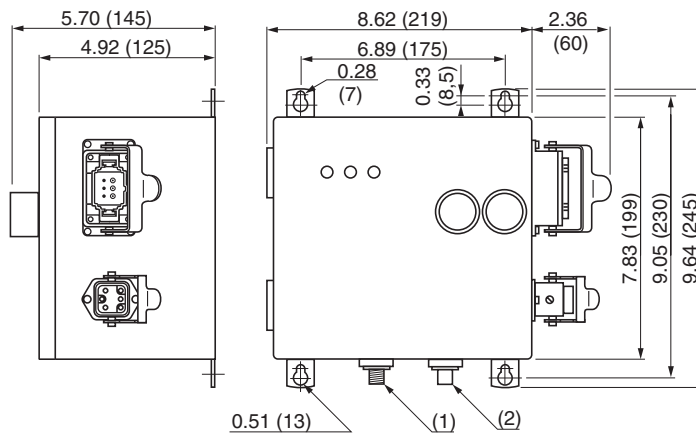

- (1) M12 male connector for connection to the AS-i bus
- (2) M12 female connector for sensor connection

Dim.: in. (mm)



# AS-i Metal Enclosed DOL Starters Dimensions—Pushbutton Control

1 or 2-direction starters with pushbutton control – Metal enclosure  
With cable gland  
LF●MM●DA79

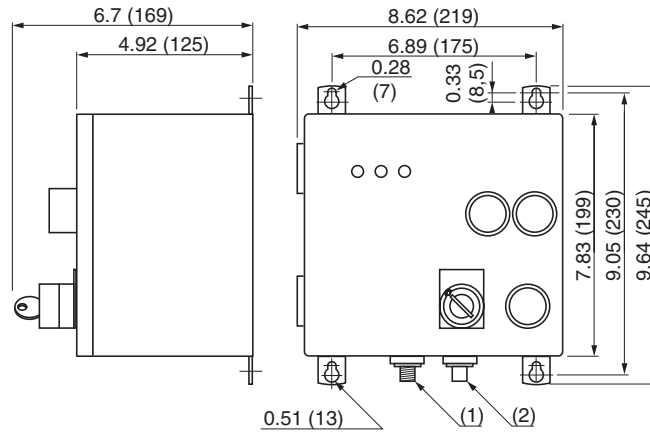

With HARTING plug-in connectors (A74) – Metal enclosure  
LF●MM●DA79A74

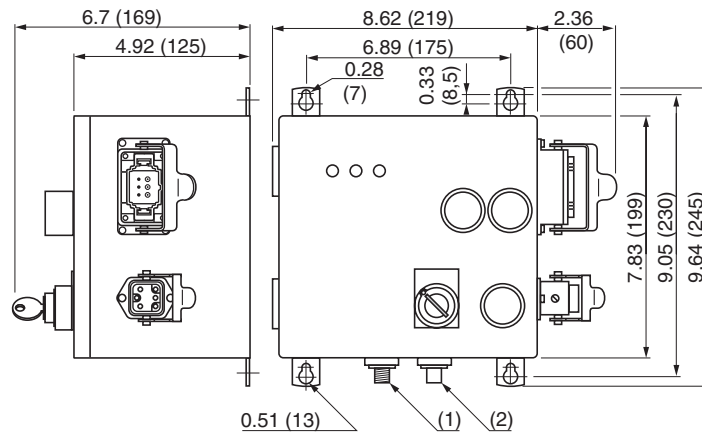

- (1) M12 male connector for connection to the AS-i bus
- (2) M12 female connector for sensor connection

Dim.: in. (mm)



# AS-i Metal Enclosed DOL Starters Connection Overview

## Connection through Cable Glands

Cable glands with gaskets and M12 connector systems must be installed as shown in order to meet IP55 rating.

Knock-outs on the upper part can be used for other methods of connection (e.g., a 24 V power cable through a cable gland instead of an M12 connector).

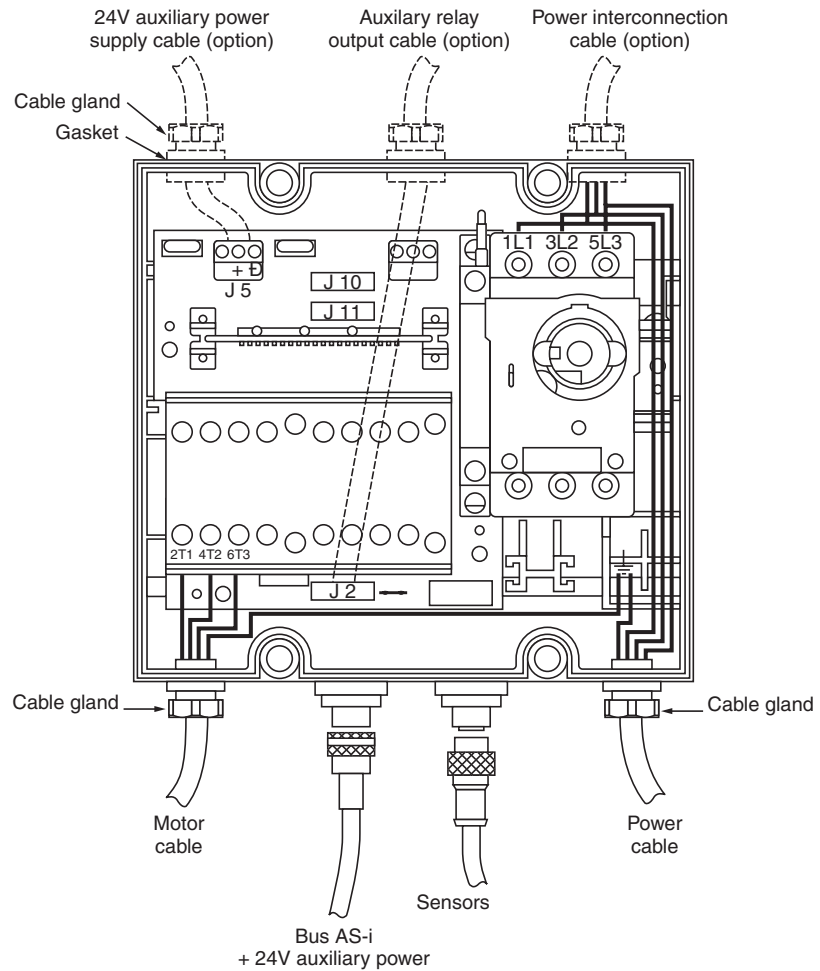

# AS-i Metal Enclosed DOL Starters Connection with Plug-In Connectors

## Connection through Plug-In Connector (HARTING Type)

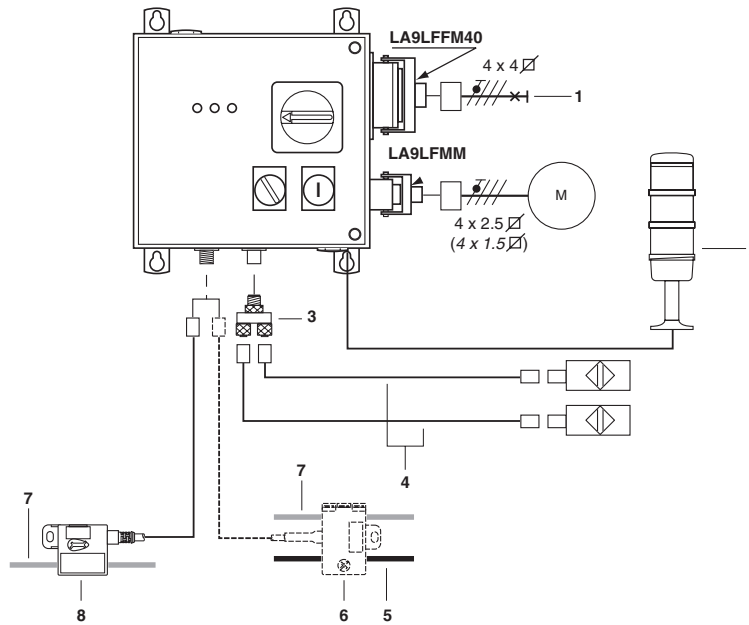

1. Power unit (1)
2. Auxiliary relay (e.g. light column)
3. XZLC122C1: Splitter
4. XZCR1511040A: Extension
5. XZCB10002: Black ribbon cable for auxiliary power supply
6. XZCG1403D: Two-cable tap-off box
7. XZCB10001: Yellow ribbon cable for AS-i bus
8. XZCG01205D: Single cable tap-off box

Configuration of the connectors to be fitted to cables (order separately).

- Telemecanique connection kits:
  - power input = LA9LFFM40
  - motor connection = LA9LFMM + LA9LFM15 (1.5 mm<sup>2</sup>) or LA9LFM25 (2.5 mm<sup>2</sup>)
  - crimp tool and insertion tool = AT1PAH
- HARTING connection kits:

Description	Straight backshell	Plug to crimp 6 contacts, 400 V	Socket to crimp 6 contacts, 400 V	Male contacts 2.5 mm <sup>2</sup> (to crimp)	Female contacts 4 mm <sup>2</sup> (to crimp)
Power input female connector	09-30-006-0442 (PG21) 09-30-006-0443 (PG29)		09-33-006-2702		09-33-000-6207
Male connector for motor connection	09-20-003-1440	09-12-005-3001		09-33-000-6102	

## Applications

The starter does not require an auxiliary supply to operate the contactors, since current provided by the AS-i bus (yellow cable) is sufficient. Again, this reduces the cabling required.

However, depending on the application, it is possible to supply the contactor coils by an external 24 Vdc source. Selection is made by repositioning a jumper within the starter.

Prospective current consumptions are listed on page 12.

# AS-i Metal Enclosed DOL Starters Sensor Connection

## Sensor Connection

Three types of sensors can be connected directly to the starter using the 5-pin M12 female connector:

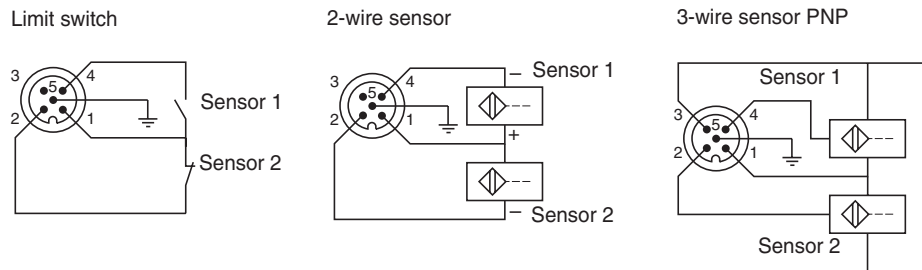

The use of sensors equipped with M12 connectors facilitates installation.

For reflex stop (see page 7), you must use sensor 1 (PNP-NO or a dry NO contact on pin 4).

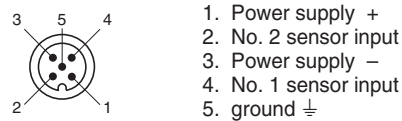

For two-sensor connections, use M12 splitter XZ-LC1220 C1.

For a single-sensor connection, connect directly to the M12 female connector on the enclosure. Use the No. 1 sensor channel.

## Auxiliary Relay Output

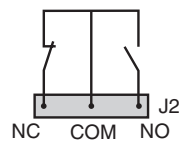

Single pole, double throw (SPDT), single break contact.

# AS-i Metal Enclosed DOL Starters Block Diagrams

## Block Diagrams

See "Important Application Information for AS-i DOL Starters" on page 3.

### Non-reversing direct-on-line starters with sensor

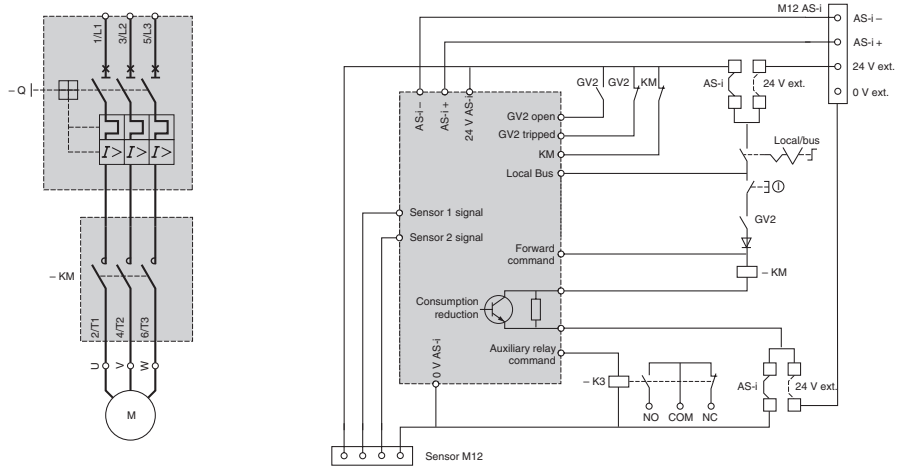

### Reversing direct-on-line starters with sensor

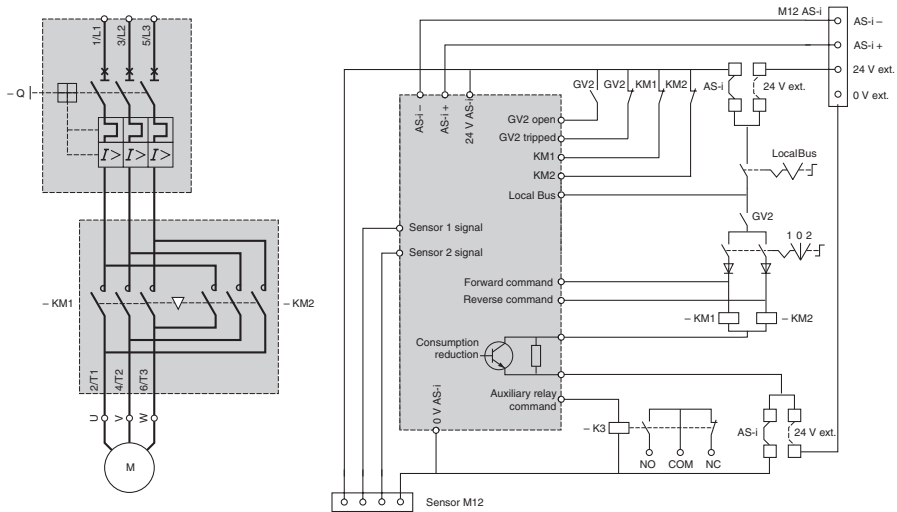

## WIRING DIAGRAMS

- Starters without sensor with contactor supply via the AS-i bus

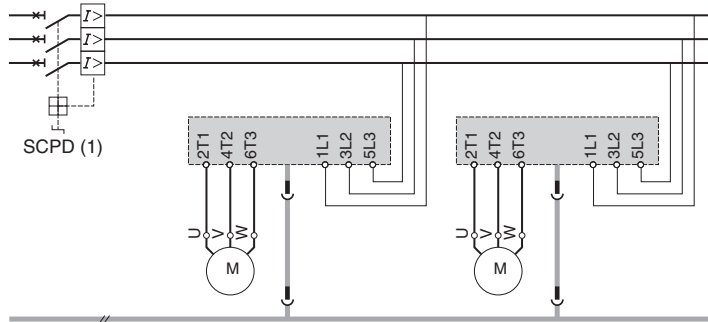

- Starters with sensor and 24 V DC auxiliary supply

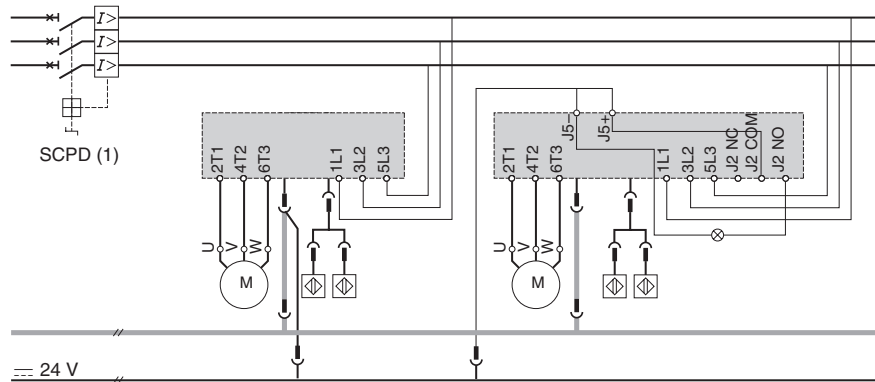

(1) Short Circuit Protection Device. See "Important Application Information for AS-i DOL Starters" on page 3.

Square D Company  
8001 Highway 64 East  
Knightdale, NC 27545  
1-888-SquareD  
(1-888-778-2733)  
[www.SquareD.com](http://www.SquareD.com)

Schneider Canada Inc.  
19 Waterman Avenue,  
M4B 1 Y2  
Toronto, Ontario  
1-800-565-6699  
[www.schneider-electric.ca](http://www.schneider-electric.ca)

Catalog No. 8340CT0101R2/02 March 2002 Replaces 8340CT0101 dated 05/01.  
© 2001–2002 Schneider Electric All Rights Reserved