

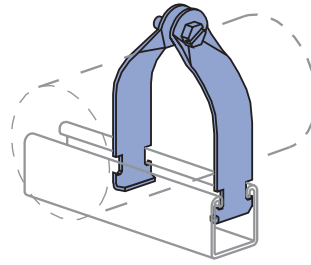

P1211 THRU P1217

UNIVERSAL CLAMPS FOR RIGID OR THINWALL CONDUIT

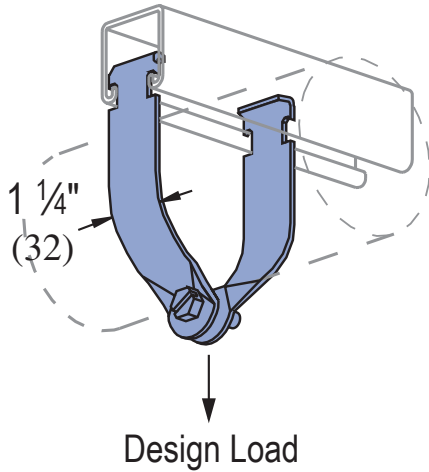

Slotted hex head screw and nut included with EG or HG Finish.

Part No.	Conduit Size In (mm)	Thickness Gauge (mm)	Wt/100 pcs Lbs (kg)	Design Load Lbs (kN)
P1211	1/2	16	10	400
	13	1.5	4.5	1.78
P1212	3/4	16	11	400
	19	1.5	5.0	1.78
P1213	1	16	12	400
	25	1.5	5.4	1.78
P1214	1 1/4	14	18	600
	32	1.9	8.2	2.67
P1215	1 1/2	14	20	600
	38	1.9	9.1	2.67
P1217	2	14	22	600
	51	1.9	10.0	2.67

MATERIAL

Unistrut pipe clamps, unless noted, are punch-press made from hot-rolled, pickled and oiled steel plates, strip or coil, and conform to ASTM specifications A1008, A575, A576, A635, or A36. The fitting steel also meets the physical requirements of ASTM A1011 SS GR 33. The pickling of the steel produces a smooth surface free from scale.

Many items are also available in stainless steel.

Consult factory for ordering information.

FINISHES

Pipe supports are available in:

- Electro-galvanized (EG), conforming to ASTM B633 Type III SC1
- Hot-dipped galvanized (HG), conforming to ASTM A123 or A153 (hardware)
- Perma-Green III (GR), and plain (PL).

Project: _____ Architect / Engineer: _____ Date: _____ Phone: _____ Contractor: _____ Address: _____ _____ Notes 1: _____ _____ Notes 2: _____ _____	Approval Stamp:
---	--