

MOVTEC AND TDS-MOVTEC SURGE DIVERTERS

INSTALLATION INSTRUCTIONS

**Includes MPM Movtec Protection
Module Instructions**

ERICO[®]

www.erico.com

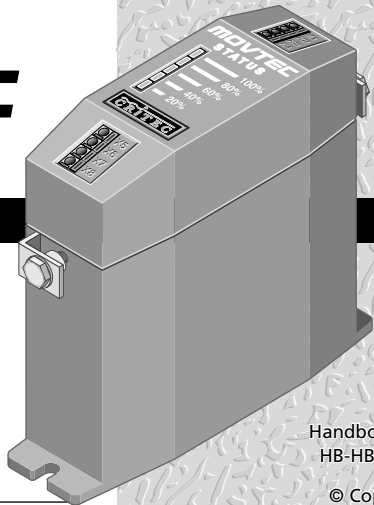

Handbook No:
HB-HBCR-111

© Copyright

ISSUE: 3 April 2003

INSIDE FRONT COVER

(Blank)

CONTENTS

	Page		Page
1. Warnings	4	9. Isolation and Fusing	20
2. Introduction	5	10. Status Indication and Alarms	22
3. Protection Concepts	7	11. MPM, Movtec Protection Module	24
4. Mounting and Cautions	9	12. Maintenance and Testing	27
5. Voltage Ratings	10	13. Extended Warranty	28
6. Protection Mode	13	14. Six Point Plan	29
7. Connection Method	15	15. Use of Mimic Panels	30
8. RCD, ELCB	20		

I. WARNINGS

- Prior to installation ensure that the Movtec is of the correct voltage and frequency, and is the type recommended for the local power distribution, and for the equipment being protected.
- Hazardous voltages may exist internally to the units. The units should be installed (and replaced) only by qualified personnel in accordance with all relevant Electricity Safety Standards.
- Do not power MPMs and three phase connected Movtecs (Ph-N) without the upstream neutral connected. Failure to do so may damage the Movtecs and/or the load.
- Where the MPMs/Movtecs are connected to an earth, this must be a low impedance earth ($<10 \Omega$) for correct operation.
- X1-X4 connections may be at phase voltages dependant upon connection method.
- If connecting to the Movtec alarm outputs do not exceed the maximum permissible ratings as damage may occur.
- Movtecs must be installed in an enclosure or panel, ensure this does not cause their environmental ratings to be exceeded.
- Do not “Megger” or “Flash Test” circuits with Movtecs installed.
- The DINLINE Surge Counter (DSC) should not be used in voltage sensing mode with TDS-Movtecs. Voltage sensing mode is not compatible with TDS-Movtecs.
- All instructions must be followed to ensure correct and safe operation.
- Diagrams are illustrative only, and should not be relied on in isolation.

2. INTRODUCTION

Movtecs are designed to protect mains powered equipment from the damaging effects of lightning and transients. They are ideal for point-of-entry shunt protection applications where robustness and high surge ratings are required.

The Movtec family is designed to suit many distribution systems including TN-C, TN-S, TN-C-S and TT. They can be selected for use with distribution systems with nominal voltages of 110/120V, 220/240V and 277Vrms at frequencies of 50/60 Hz.

The TDS Technology (Transient Discriminating Suppressor) units are specifically designed for distribution systems that may feature poor voltage regulation where the actual supply voltage may exceed the nominal ratings for extended periods.

This Installation Manual details the preferred procedure for the installation of the family of Critec Movtec™ Surge Diverters.

The Critec Movtec family includes:

- Critec Movtec, Single Mode, enhanced MOV technology units eg. (MT275V-135K-A)
- Critec TDS-Movtec, Single Mode, TDS technology unit featuring high over-voltage withstand for added robustness (TDS-MT-277)
- Critec TDS-Movtec, Three Mode, TDS technology unit featuring high over-voltage withstand for added robustness (TDS-MTU)

TDS-Movtec units are coloured blue for easy identification, while enhanced MOV technology units are coloured red.

In this manual, reference to “Movtec” also includes “TDS-Movtec”.

This manual also details the installation of the MPM (Movtec Protection Module). The MPM is a supplied enclosure with three Movtecs and a high energy neutral to earth protection device for three phase protection. The MPM is often used where Movtecs can not be fitted in an existing switchboard and must be mounted externally. Therefore the Movtec installation instructions are also applicable to the MPM. Section 11 gives details which are specific to the MPM.

Two standard MPMs are available:

- Critec TDS-MPM, Single Mode, TDS Technology unit (uses 3 x TDS-MT-277)
- Critec MPM-275V, Single Mode, Enhanced MOV Technology unit (uses 3 x MT275V-135K-A)

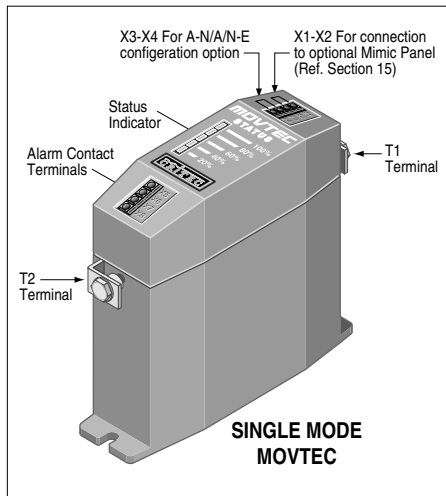

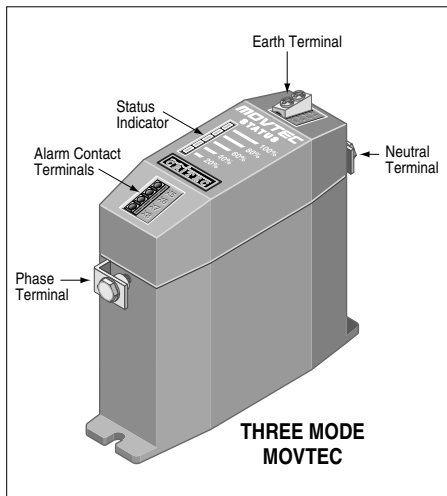

3. PROTECTION CONCEPTS

To optimise effectiveness of installed protection a concept of “Unprotected” and “Protected” wiring should be followed. Wiring from the transient source to the Movtec should be considered “Unprotected” and kept remote from all other wiring (approximately 300mm) where possible. Wiring on the equipment side of the Movtec should be considered “Protected”.

The separation of “Protected” from “Unprotected” wiring is recommended in order to minimise the risk of transients conducted on “Unprotected” wiring cross coupling on to “Protected” circuits, thus compromising the level of protection available from the Movtec.

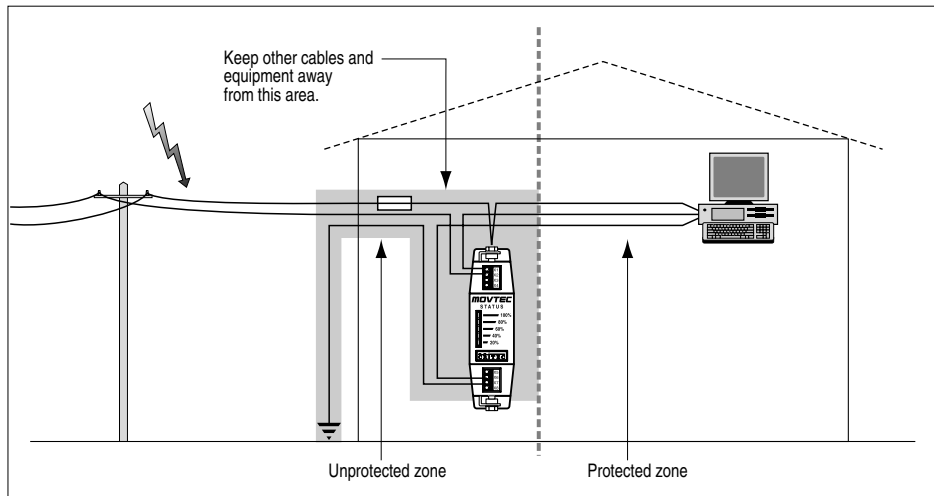

4. MOUNTING & CAUTIONS

The performance of surge diverters can be dramatically affected by the method of connection (refer section 7). Where possible select a mounting method that allows the Movtec to be connected in the “Preferred Connection Method”.

Failure of a Movtec under severe AC over-voltage, such as 11kV on 240V mains, can result in the generation of significant heat. Consideration should be given to ensure that Movtecs are not installed in close proximity to combustible materials.

Units must be installed in an enclosure or panel to provide the appropriate degree of electrical and environmental protection.

Only use enclosures that:

- Do not cause the Movtec temperature to exceed 60 deg C
- Provide adequate electrical and safety protection
- Prevent the ingress of moisture and water
- Allow Movtec Status Indication to be inspected

5 VOLTAGE RATINGS

The TDS (Transient Discriminating Suppressor) technology has been specifically developed to cater for abnormal over-voltage conditions that may occur on sites with poor voltage regulation, or due to wiring or distribution faults. The TDS units feature an extremely high over-voltage withstand to eliminate heat build up that can occur with standard technologies when the protection devices start to clamp on the peak of each abnormal mains cycle.

Traditional MOV technology (eg MT-275V/135K/A) is not suitable in applications where sustained over-voltage conditions can be experienced.

Examples of poorly regulated voltage environments include:

- Smaller power generation supplies
- Sites with large earth currents
- Variable motor speed control circuits
- High harmonic voltage environments (non-linear loads)

The TDS range of Movtecs with a higher over-voltage withstand may be able to be used in these environments following advice.

Transient protection devices are usually rated to protect against non-repetitive pulses from such sources as direct or induced lightning strikes. They are not designed to provide protection against repeated cyclic anomalies. Nor are they designed to provide protection

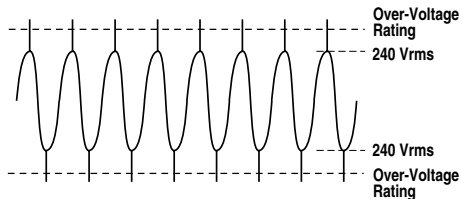

Avoid repetitive voltages in excess of rating

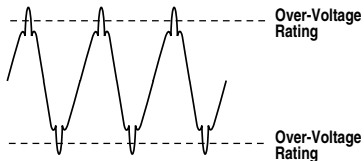
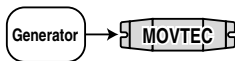

Avoid high harmonic voltages

against *sustained over-voltage conditions where the supply voltage exceeds the protection equipment's nominal rating for an extended period of time*, ie continuous over-voltages from poorly regulated generators or distribution systems.

Smaller power generation equipment (particularly capacitive excitation induction generators) does not generally conform to the same standards of voltage regulation that are in place for mains power reticulation. A large number of smaller and/or cheaper generators have a voltage waveform that is "loosely" 240Vrms (often poorly regulated), but more importantly, often contains significant higher order harmonics. These generators may exhibit a peak voltage on each half cycle far in excess of the normal 340V. The problem is usually worse when the generator is lightly loaded.

Whilst electrical equipment may tolerate this over-voltage for a period of time, the clamping elements in the power protection devices will begin to conduct on the peak of each 50Hz cycle, as their voltage threshold is reached (typically 400V peak for a traditional 275V diverter). This will cause slow degradation and ultimate failure of the clamping device (time dependent upon how poor the waveform is).

Harmonic voltages may also be present in distribution systems that do not feature generators. This is normally where non-linear loads are used, such as UPSs, rectifiers, switch mode power supplies and motor speed controls. The high harmonic voltages in certain applications may have peak voltages in excess of the protective clamping voltage causing problems as described above. Seek the manufacturer's advice before installing any

product into a circuit which features a total harmonic voltage ratio above 5%.

Model	Nominal Voltage	†Maximum Permissible Abnormal Over-Voltage
TDS-MT-277	220-277V	480V
TDS-MTU	220-277V	480V
MT275V-135K-A	220-240V	275V

Ensure that the correct voltage rating unit is installed. Exceeding the nominal rating while transient events occur may affect product life.

† *Note: Other voltage rating Movtecs are available. Refer to Movtec table for actual ratings.*

6. PROTECTION MODES

Movtecs are available in Three Mode and Single Mode configurations. This refers to how the internal protection is arranged and applied to the circuit to be protected.

Three Mode units provide protection between the Phase-Neutral*, Phase-Earth* and Neutral-Earth circuit within one Movtec.

Single Mode units provide protection between two conductors connected to the terminals marked T1 and T2. These units can be connected to provide protection from Phase-Neutral* or Phase-Earth* or Neutral-Earth. To allow the status indication and alarm circuitry to operate, a neutral connection is required for Phase-Earth* configured units, and a Phase* connection is required for

Neutral-Earth configured units. Connection details for single mode units are detailed on page 15. Warning - this connection link can be at mains potential.

* Note. Some users may be used to the terminology “Active” or “Line”, in place of “Phase”. For consistency “Phase” is used throughout this documentation.

Model	Modes
TDS-MTU	Three Mode
TDS-MT-277	Single Mode
MT275V-135K-A	Single Mode

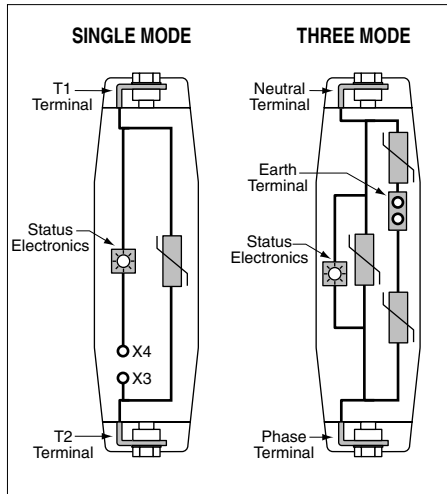

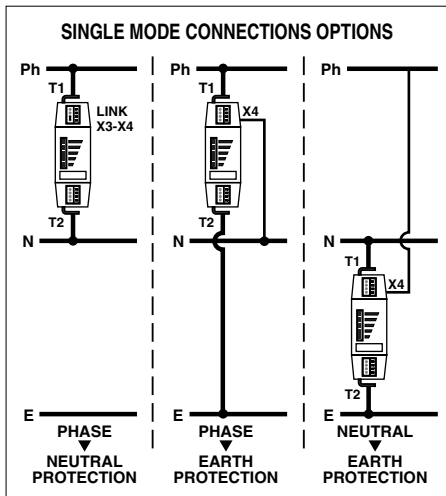

7. CONNECTION METHOD

To optimise transient performance, attempt to connect the Movtecs in the “Preferred” fashion as depicted on pages 16 and 17. This is recommended for cable sizes between 6mm² and 16mm². Take care not to run the protected and unprotected wire parallel or in close proximity.

Where this is not possible due to layout or conductor size, use the “Non-preferred” “T” connection method as depicted on pages 16 to 18. With this connection method, the “T” lead should be between 6mm² and 16mm². The connection should be as short as practicable (less than 100mm).

Cable sizes less than 6mm² should not be used without specialist advice.

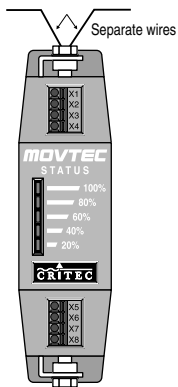
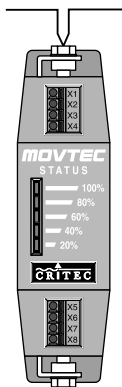
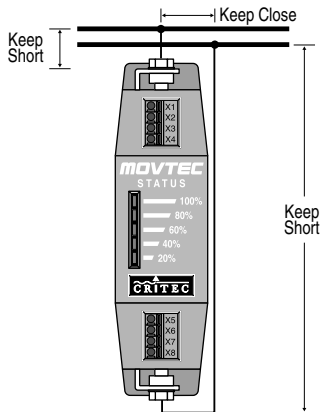
PREFERRED CONNECTION METHOD
✓ CORRECT

~~X~~ INCORRECT

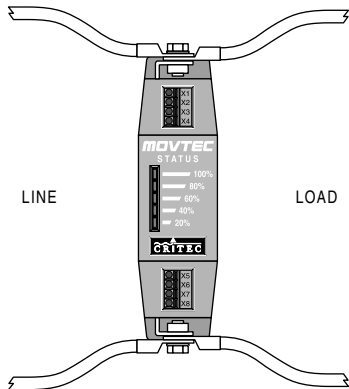
NON-PREFERRED "T" CONNECTION METHOD

PREFERRED CONNECTION METHOD EXAMPLES



LINE

LOAD

SINGLE MODE UNITS

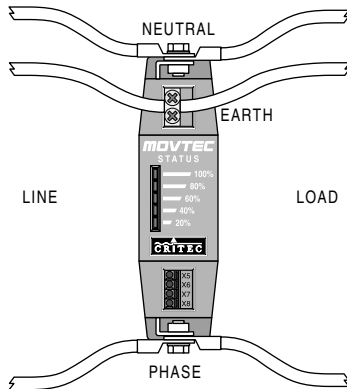

LINE

LOAD

PHASE

THREE MODE UNITS

NON-PREFERRED "T" CONNECTION METHOD EXAMPLES

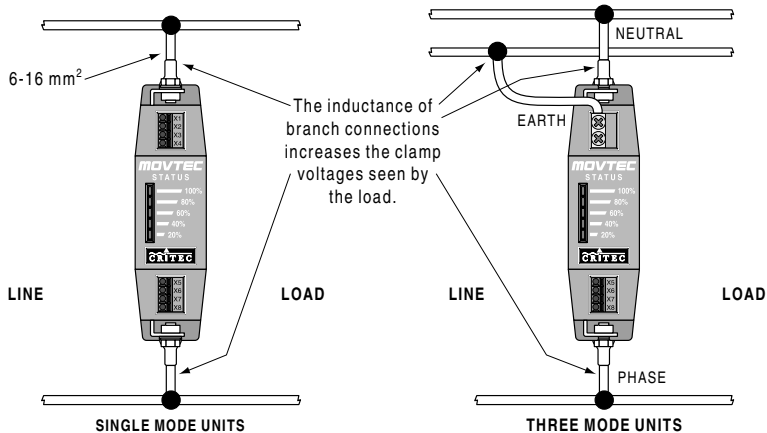

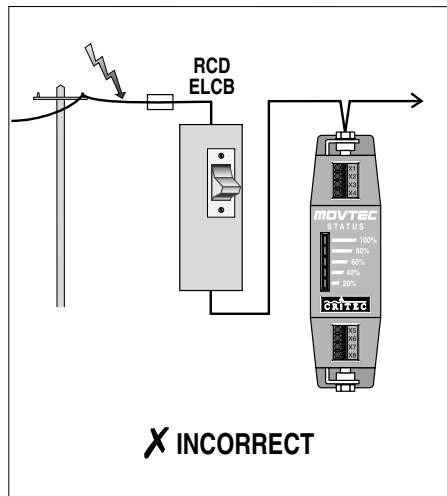
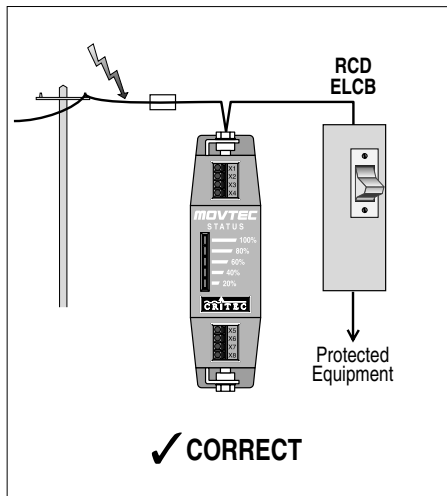

8. RCD, ELCB

Where RCDs/ELCBs (Residual Current Devices / Earth Leakage Circuit Breakers) are fitted the Movtecs should be installed in the circuit prior to these devices (ie upstream).

Where this can not be avoided and RCDs/ELCBs are installed upstream, nuisance tripping of the RCD/ELCB may occur during transient activity.

Contact your local ERICO agent for advice if upstream RCDs/ELCBs can not be avoided.

9. ISOLATION AND FUSING

Overcurrent and short circuit protection must be provided to protect the Movtec and associated wiring if a fault develops. The overcurrent protection should be installed in such a manner to also provide a means of isolating the Movtec module from the mains supply. This is an important safety consideration and is required in the event that any future maintenance or testing is needed.

The Movtec uses disconnection devices to isolate internal segments that have reached the end of their service life. In order for this disconnection to occur correctly, Movtecs should be only used on circuits with fuse or circuit breaker ratings of 32A or greater. (Nuisance operation of the overcurrent protection may occur during transient activity on smaller capacity circuits.)

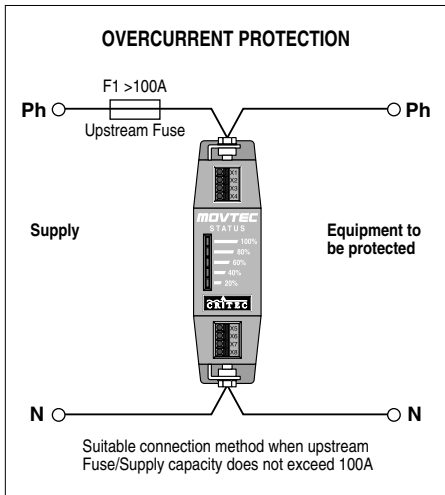
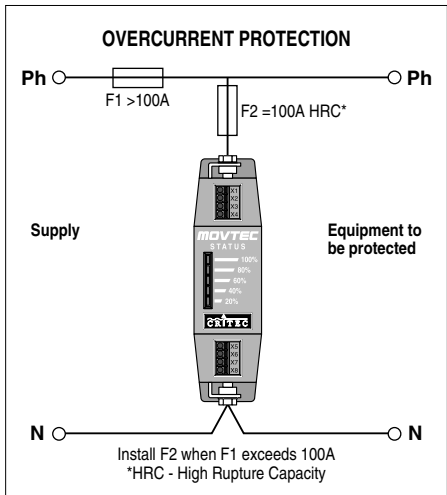

On circuits with a capacity of greater than 100A, the Movtecs should be installed in series with a 100A HRC fuse being placed prior to the Movtec, as detailed in the diagram on page 21. This will require the Movtec to be installed in a similar manner to the non-preferred "T" connection method. Care must be taken to keep "T" connections as short and straight as possible. Note that this fuse may rupture under surge events exceeding 60kA, thereby disconnecting the protection circuit. Under such conditions it is important that suitable monitoring of the alarm contact should be carried out to detect this possible occurrence.

10. STATUS INDICATION AND ALARMS

A characteristic of **all** transient and surge protection devices is that they degrade in proportion to the magnitude and number of incident surges to which they have been subjected. Status indication should be periodically monitored to determine if replacement is required.

Each Movtec features 5 protection segments. The status for each of these sectors is provided by way of a 5 segment LED bar graph. If any sector is damaged due to excess surge activity, a LED will extinguish. The LEDs extinguish in a sequential order (100% LED out first, 80% LED out next etc.) irrespective of which sector has sustained damage.

When mains voltage is applied to the fully functional Movtec, the alarm contacts will be **closed**. Should the surge handling capacity fall to below the alarm threshold, these contacts will **open**. The contacts are “fail-safe” in that, if power to the unit fails, the contacts will also revert to the open condition.

For Single Mode units (TDS-MT-277 and MT275V-135K-A)

- The voltage free alarm contacts are activated (opened) as soon as the primary protection status displays 60% or less and indicates that the Movtec unit should be replaced.

For Three Mode units (TDS-MTU)

- The voltage-free alarm contacts are activated (opened) as soon as the protection status displays 80% or less. This indicates that damage has been sustained to the protection

of one of the three modes and that the TDS-Movtec unit should be replaced.

MOVTEC MODEL	TERMINALS	ALARM OPERATES WHEN
TDS-MT-277	X5 & X7	MOVTEC displayed capacity = < 60%
MT275V-135K-A	X5 & X7	MOVTEC displayed capacity = < 60%
TDS-MTU	X5 & X7	MOVTEC displayed capacity = < 80%
Contact Rating Contact connection	250Vac, 10A resistive, 1A inductive Multi-stranded wire with CSA not greater than 1.5mm ²	

Where multiple Movtecs are used, such as in three phase distribution systems the alarm contacts may simply be connected in series to provide a common alarm output connection.

II. MPM, MOVTEC PROTECTION MODULE

The MPM utilises a high energy Neutral to Earth spark gap to provide robust protection against earth potential rise problems. Care is required to ensure co-ordination of this device

if any other voltage limiting device is connected either upstream or downstream in the Neutral to Earth circuit. **Contact your local agent for further information if other N-E protection devices are installed and co-ordination may be affected.**

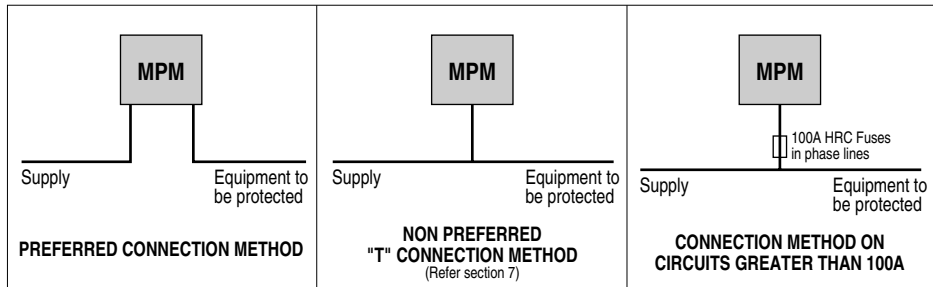

INSTALLATION PROCEDURE FOR MPM

1. Remove the cover from the MPM.
2. Select the MPM mounting position to ensure optimum electrical connection method (refer Section 7) and in accordance with all given instructions.
3. Position and mark the mounting position of the MPM on the wall.
4. Depending on the mounting surface, prepare suitable anchoring holes for the marked position.
5. Snap the mounting spacers, supplied, into the rear of the back of the MPM as shown in Figure 1. (*see inside back cover P31*)
6. Mount the unit to the wall. To ensure the IP33 rating is preserved, the MPM should be mounted to the wall using the spacers provided and one of the fixing methods as shown in Figure 1. (*see inside back cover P31*)
7. Prepare the appropriate cable glands. It is recommended that a nylon cable gland (typically rated at IP66) be used.
8. Install wiring, taking care to support cabling directly connecting to the MPM unit, and tighten all terminals.
9. Check that the MPM is installed in accordance with all instructions, and relevant electrical safety codes.
10. Replace MPM cover, then apply power.
11. Correct operation of the MPM unit is established by checking that all 5 LED's on each MOVTEC bar graph are lit, and that power is correctly being supplied to the load(s).

INSTALLATION ARRANGEMENT FOR AUSTRALIAN MEN SYSTEMS

Under Australian Standards classification, MPMs are considered a piece of equipment to

be connected to the mains supply. The MPMs are not intended for use as, nor are they, a 'switch board', 'distribution board' or other equipment. As MPMs are classified as 'electrical equipment' (ie: a product), AS 3000 Wiring Regulations apply to the installation and operation of the units.

In the multiple earth neutral (MEN) distribution system, the MPM equipment should be installed as close as possible after the MEN point and after both the main disconnect switch/overcurrent protector and any metering equipment.

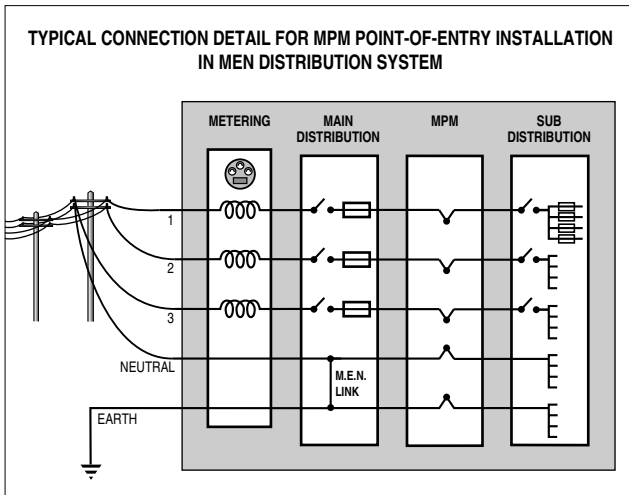

12. MAINTENANCE & TESTING

Before removing any unit from service ensure that power to the device is isolated. Replacement of any Movtec units should only be undertaken in accordance with all relevant Electricity and Safety Standards by suitably qualified personnel.

Movtecs should be inspected periodically, and also following any periods of lightning or transient activity. Check the status indicators and replace if in the “Alarm” condition as detailed in Section 10 -STATUS INDICATION.

For high transient exposure sites or those of a critical operational nature, it is recommended that the alarm outputs be monitored to provide an additional warning of reduced capacity (refer Section 10).

Movtecs are designed for optimum performance under severe transient activity. To provide this performance, electronic components in the Movtec are encased in a patented proprietary, shock and thermal absorbant compound. **Units cannot be serviced, they must be replaced.**

Do not attempt to open or tamper with the units in any way as this may compromise performance and will void warranty.

Do not “Megger” or perform other types of electrical tests that apply voltages greater than the nominal operating voltage of the Movtec. The Movtec will attempt to limit these voltages thereby affecting the test result. Where these tests must be performed, remove the Movtec from circuit first.

13. EXTENDED WARRANTY

This product has a limited warranty to be free from defects in materials and workmanship for a period of five (5) years from the date of dispatch from the Manufacturer. The Purchaser acknowledges that lightning is a natural event with statistical variation in behaviour and energy levels which may exceed product ratings, and 100 % protection is not offered and cannot be provided for. Therefore the Manufacturer's liability is limited to the repair or replacement of the product (at the Manufacturer's sole option) which in its judgement has not been abused, misused, interfered with by any person not authorised by the Manufacturer, or exposed to energy or transient levels exceeding the Manufacturer's specifications for the product. The product must be installed and earthed (where applicable) in strict accordance with the Manufacturer's specifications and all relevant national Electricity and Safety Standards. The Manufacturer and the

Purchaser mutually acknowledge that the product, by its nature, may be subject to degradation as a consequence of the number and severity of surges and transients that it experiences in normal use, and that this warranty excludes such gradual or sudden degradation. This warranty does not indemnify the Purchaser of the product for any consequential claim for damages or loss of operations or service or profits. Customers should contact their nearest manufacturer's agent to obtain a Product Repair Authorisation Number prior to making any claim under this warranty. This is only a summary of the warranty given by the Manufacturer. The full text of the warranty is set out in the Manufacturer's Conditions of Quotation and Sale. The above limited warranty is additional to rights which arise in respect of the sale of industrial and technical products and services to knowledgeable buyers under the Australian Trade Practices Act 1974 as amended.

14. SIX POINT PLAN

Critec Movtec surge diverters form an important part of the much larger ERICO lightning, surge and transient protection philosophy (ERICO Lightning Technologies "Six Point Plan"). The level of protection and the degree of attention dedicated to each of the six points will require careful consideration for each site. The degree of protection required is determined by the individual site location/exposure with the aid of risk management principals.

For further advice on your protection needs please contact your local representative.

ERICO LIGHTNING TECHNOLOGIES' SIX POINT PROTECTION PLAN



1
Capture the lightning strike



4
Eliminate earth loops and differentials



2
Conduct the strike to ground safely



5
Protect equipment from surges on power lines



3
Dissipate the energy through a low impedance earth system



6
Protect equipment from transients on telecommunication and signal lines

15. USE OF MIMIC PANELS

Movtecs are used in the Proline range of Surge Reduction Filters where superior protection is required for critical or sensitive electronic equipment. Some models of SRF use an electronic mimic panel to display in the

front door the status of the internal Movtecs. The X1-X4 terminals on the Movtec are used for this purpose. If this Movtec is to be used with a mimic panel (possibly as a replacement for an existing Movtec in a SRF) please ensure compatibility as below.

MOVTEC & MIMIC COMPATIBILITY			
Movtec Version	Mimic Version		
	TDS-Mimic #300732 EA-SRFP-117 EA-117	Hybrid Mimic #300731 EA-SRFP-115 EA-115	Discrete Mimic #300730 EA-SRFP-104 EA-104
TDS-MT-277	Yes	Note 1	No
MT-275V/135K/A #300867	Yes	Yes	Note 2
MT-275V/135K/A #300865/300866	Yes	Yes	Yes
Note 1	Mimic will operate for supply voltages up to 275Vrms		
Note 2	Request Product Update 44 for further details		

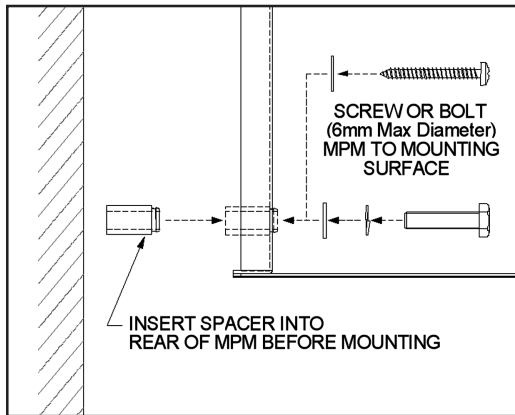
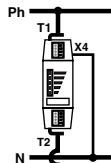

Figure 1. MPM mounting spacers.

SINGLE MODE CONNECTIONS OPTIONS



PHASE
▼
NEUTRAL
PROTECTION



PHASE
▼
EARTH
PROTECTION

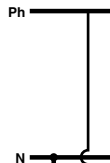

NEUTRAL
▼
EARTH
PROTECTION