

# Masterpact™ NT and NW Universal Power Circuit Breakers

Catalog  
0613CT0001 R07/15

2015

Class 0613



## CONTENTS

Description .....	Page
Masterpact™ Circuit Breakers .....	Page 3
Energy Management .....	Page 19
Micrologic™ Electronic Trip Systems .....	Page 37
Accessories .....	Page 69
Wiring Diagrams .....	Page 95
Masterpact NT Dimensional Drawings .....	Page 102
Masterpact NW Dimensional Drawings .....	Page 144
Accessory Dimensional Drawings .....	Page 205
Selection .....	Page 212
Trip Curves .....	Page 225



## Section 1—Masterpact™ Circuit Breakers

Introduction .....	4
Codes and Standards .....	4
Features and Benefits .....	5
Operating Conditions .....	8
Masterpact NW Circuit Breaker Design .....	9
Masterpact NW Cradle Design .....	10
Masterpact NT Circuit Breaker and Cradle Design .....	12
Ratings .....	13
Correction Factors .....	17
Shipping Weights .....	18

# Masterpact™ NT and NW Universal Power Circuit Breakers

## Masterpact™ Circuit Breakers

### Introduction

Masterpact™ NT/NW Universal Power Circuit Breakers are designed to protect electrical systems from damage caused by overloads, short circuits and equipment ground faults. All Masterpact circuit breakers are designed to open and close a circuit manually, and to open the circuit automatically at a predetermined overcurrent setting. Masterpact circuit breakers can also:

- Enhance coordination by their adjustability.
- Provide integral ground-fault protection for equipment.
- Provide high interrupting ratings and withstand ratings.
- Provide communications.
- Provide power monitoring.
- Provide protective relaying functions.
- Provide zone-selective interlocking (ZSI) which can reduce damage in the event of a fault.



800–1600 A Masterpact NT Drawout Circuit Breaker

Figure 1: Masterpact NW Drawout Circuit Breakers

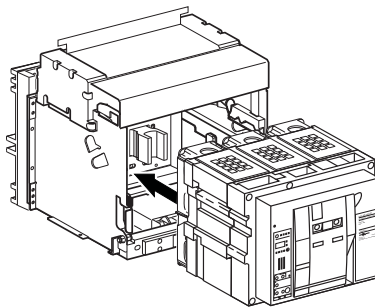

800–3200 A Masterpact NW Drawout Circuit Breaker

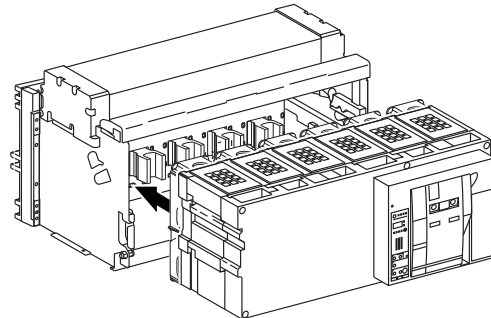

4000–6300 A Masterpact NW Drawout Circuit Breaker

### Codes and Standards

Masterpact circuit breakers are manufactured and tested in accordance with the following standards:

Low-Voltage Power Circuit Breaker	Insulated Case Circuit Breaker	IEC Rated Circuit Breaker	IEC Extreme Atmospheric Conditions
ANSI C37.13			
ANSI C37.16	UL 489 (UL Listed)		IEC 68-2-1: Dry cold at -55°C
ANSI C37.17	NEMA AB1	IEC 60947-2	IEC 68-2-2: Dry heat at +85°C
ANSI C37.50	CSA C22.2 No. 5	IEC 60947-3	IEC 68-2-30: Damp heat (temp. +55°C, rel. humidity 95%)
UL 1066 (cULus Listed)	NMX J-266-ANCE		IEC 68-2-52 Level 2: Salt mist
NEMA SG3			

**NOTE:** Throughout this document, the phrase “ANSI® Certified” means the product meets the requirements of UL 1066 and ANSI C37. When “UL® Listed” appears, the product meets the requirements of UL 489.

The 800–2000 A ANSI Low Voltage Power Circuit Breakers type L1F and Insulated Case Circuit Breaker type LF are tested to show the arc flash hazard risk category as referenced by NFPA® 70E.

Circuit breakers should be applied according to guidelines detailed in the National Electrical Code® (NEC®) and other local wiring codes.

Masterpact circuit breakers are available in Square D™ or Schneider Electric™ brands.



# Masterpact™ NT and NW Universal Power Circuit Breakers

## Masterpact™ Circuit Breakers

### UL File Numbers:

- Masterpact NW: E161835 Vol. 2 Sec. 1
- Masterpact NT: E161835 Vol. 2 Sec. 2

### Features and Benefits

**High Ampere Interrupting Rating (AIR):** ANSI Certified Masterpact NW circuit breakers have an interrupting rating of 200,000 A at 508 Vac without fuses.

**High Short-Time Current Rating:** Masterpact NW circuit breakers have exceptional short-time ratings—up to 100,000 A.

**100% Rated Circuit Breaker:** Masterpact circuit breakers are designed for continuous operation at 100% of their current rating.

**Reverse Fed Circuit Breaker:** Masterpact circuit breakers can be fed either from the top of the circuit breaker or from the bottom.

**Two-Step Stored Energy Mechanism:** Masterpact circuit breakers are operated via a stored-energy mechanism which can be charged manually or by a motor. The closing time is less than five cycles. Closing and opening operations can be initiated by remote control or by push buttons on the circuit breaker front cover. An O–C–O cycle is possible without recharging.

**Drawout or Fixed Mount, 3-Pole (3P) or 4-Pole (4P) Construction:** ANSI Rated, UL Listed and IEC Rated Masterpact circuit breakers are available in drawout or fixed mounts, with either three-pole or four-pole construction.

**Field-Installable Trip Units, Sensor Plugs and Accessories:** Trip units, sensor plugs and most accessories are field installable with only the aid of a screwdriver and without adjusting the circuit breaker. The uniform design of the circuit breaker line allows most accessories to be common for the whole line.

**Reinforced Insulation:** Two insulation barriers separate the circuit breaker front from the current path.

**Isolation Function by Positive Indication of Contact Status:** The mechanical indicator is truly representative of the status of all the main contacts.

**Segregated Compartment:** Once the accessory cover has been removed to provide access to the accessory compartment, the main contacts remain fully isolated. Furthermore, interphase partitioning allows full insulation between each pole even if the accessory cover has been removed.

**Front Connection of Secondary Circuits:** All accessory terminals (ring terminals are available as an option) are located on a connecting block which is accessible from the front in the connected, test and disconnected positions. This is particularly useful for field inspection and modification.

**Anti-Pumping Feature:** All Masterpact NT and NW circuit breakers are designed with an anti-pumping feature that causes an opening order to always take priority over a closing order. Specifically, if opening and closing orders occur simultaneously, the charged mechanism discharges without any movement of the main contacts keeping the circuit breaker in the open (OFF) position.

In the event that opening and closing orders are simultaneously maintained, the standard mechanism provides an anti-pumping function which continues to keep the main contacts in the open position.

In addition, after fault tripping or opening the circuit breaker intentionally (using the manual or electrical controls and with the closing coil continuously energized) the circuit breaker cannot be closed until the power supply to the closing coil is discontinued and then reactivated.

**NOTE:** When the automatic reset after fault trip (RAR) option is installed, the automatic control system must take into account the information supplied by the circuit breaker before issuing a new closing order or before blocking the circuit breaker in the open position. The information is on the type of fault, e.g. overload, short-circuit or ground fault.

# Masterpact™ NT and NW Universal Power Circuit Breakers

## Masterpact™ Circuit Breakers

**Disconnection Through the Front Door:** The racking handle and racking mechanism are accessible through the front door cutout. Disconnecting the circuit breaker is possible without opening the door and exposing live parts.

**Figure 2: Racking Handle and Mechanism**

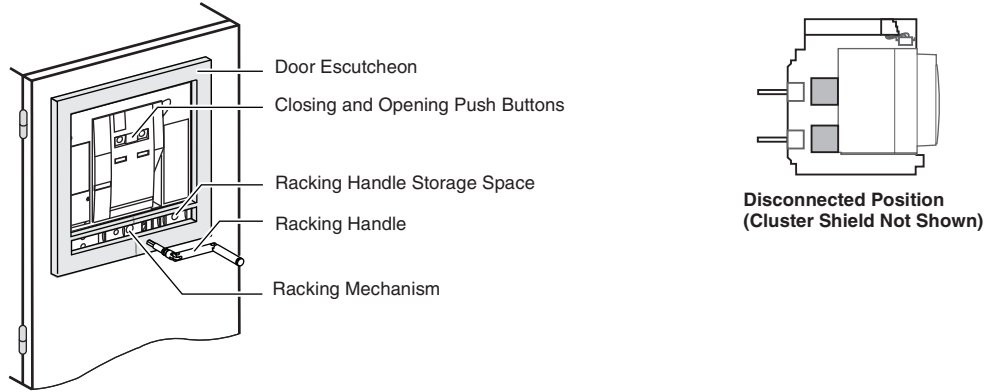

**Drawout Mechanism:** The drawout assembly mechanism allows the circuit breaker to be racked in four positions (connected, test, disconnected, or withdrawn), as shown in the figure below.

**NOTE:** For UL/ANSI circuit breakers, the clusters are mounted on the circuit breaker; for IEC circuit breakers, the clusters are mounted on the cradle.

**Figure 3: Racking Positions (Cluster Shield Not Shown)**

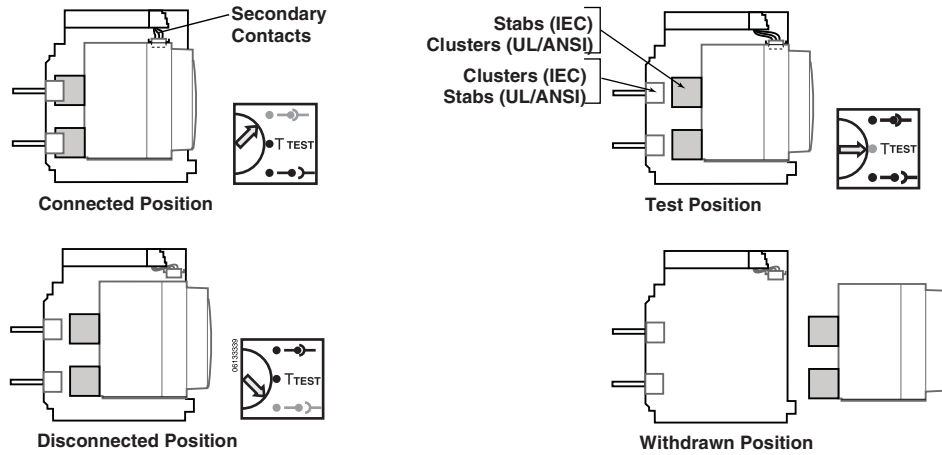

# Masterpact™ NT and NW Universal Power Circuit Breakers

## Masterpact™ Circuit Breakers

**Reduced Maintenance:** Under normal operating conditions, the circuit breaker does not require maintenance. However, if maintenance or inspection is necessary, the arc chambers are removable to allow visual inspection of the contacts and wear indicator groove (see the figure below for how wear is indicated). The operation counter can also indicate when inspections and possible maintenance should be done. The life of the circuit breaker may be extended by replacing the arc chamber and spring-charging motor and/or replacing the main contact assembly of ANSI Certified circuit breakers.

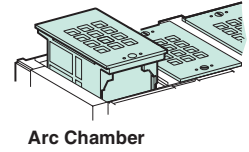

**Figure 4: Contact Wear Indicators**

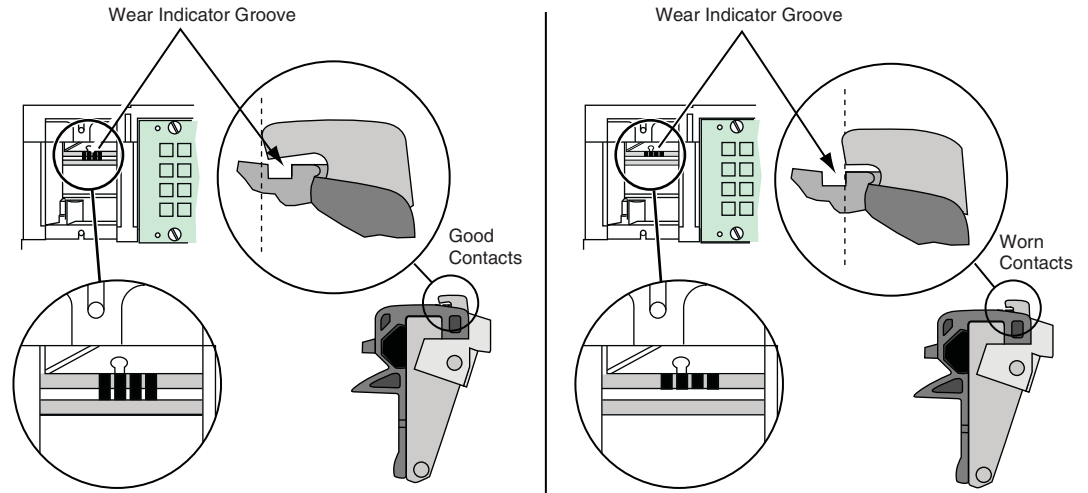

# Masterpact™ NT and NW Universal Power Circuit Breakers

## Masterpact™ Circuit Breakers

### Operating Conditions

See bulletin 0613IB1202, available in the Schneider Electric technical library, for information on normal and adverse operating conditions.

#### Ambient Temperature:

Masterpact circuit breakers can operate under the following temperature conditions:

- The electrical and mechanical characteristics are stipulated for an ambient temperature between -13°F (-25°C) and 158°F (70°C).  
Mechanical closing of the circuit breaker (by pushbutton) is possible down to -31°F (-35°C)
- At altitudes +13,000 ft. (3900 m).

Masterpact circuit breakers have been tested for operation in industrial atmospheres. It is recommended that the equipment be cooled or heated to the proper operating temperature and kept free of excessive vibration and dust. Operation at temperatures above 104°F (40°C) may require derating or overbussing the circuit breaker. See the appropriate instruction bulletin and page 17 of this catalog for additional information.

#### Storage Temperature

Circuit breakers with trip units without LCD displays may be stored in the original packaging at temperatures between -40°F (-40°C) and 185°F (85°C).

For circuit breakers with trip units with LCD displays, this range is -13°F (-25°C) to 185°F (85°C).

#### Altitude:

Masterpact circuit breakers are suitable for use at altitudes of 13,000 ft. (3900 m) and below. See Table 15 on page 17 for altitude correction factors.

#### Vibration:

Masterpact circuit breakers meet IEC 60068-2-6 Standards for vibration.

- 2 to 13.2 Hz and amplitude 0.039 in. (1 mm)
- 13.2 to 100 Hz constant acceleration 0.024 oz. (0.7 g)

#### Humidity:

Masterpact circuit breakers have been tested to the following:

- IEC68-2-30—damp heat (temperature +55°C and relative humidity of 95%)
- IEC 68-2-52 level 2—salt mist

The materials used in Masterpact NT and NW circuit breakers will not support the growth of fungus and mold.

# Masterpact™ NT and NW Universal Power Circuit Breakers Masterpact™ Circuit Breakers

## Masterpact NW Circuit Breaker Design

**NOTE:** For UL Listed and ANSI Certified circuit breakers, the clusters are mounted on the circuit breaker; for IEC Rated circuit breakers, the clusters are mounted on the cradle.

- A. Overcurrent Trip Switch (SDE1)
- B. Circuit Breaker Communication Module
- C. Overcurrent Trip Switch (SDE2) or Electric Reset
- D. Cluster
- E. Cradle Rejection Kit
- F. Lifting Tab
- G. Trip Connection to Overcurrent Trip Switch
- H. Auxiliary Control Connection
- I. Shunt Trip (MX2) or Undervoltage Trip Device
- J. Arc Chamber
- K. Shunt Trip (MX1)
- L. Auxiliary Contact Connection
- M. Two Blocks of Four Additional Switches (OF) or Combined "Connected,Closed" Switches (EF)
- N. Block of Four Form C Auxiliary Contacts (OF)
- O. Shunt Close (XF)
- P. Ready-to-Close Contact (PF)
- Q. Charging Handle
- R. Spring-Charging Motor (MCH)
- S. Closing Push Button
- T. Opening Push Button
- U. Operations Counter
- V. Trip Unit
- W. Accessory Cover
- X. Open/Close Push Button Close (Lockable with Padlock)
- Y. Faceplate
- Z. Charged/Discharged Indicator
- AA. Open/Close Indicator
- AB. Push-to-Reset on Fault Trip
- AC. Electrical Close Push Button (BPFE)
- AD. Padlock Attachment
- AE. Key Interlock
- AF. Mounting Plate for Fixed Circuit Breaker

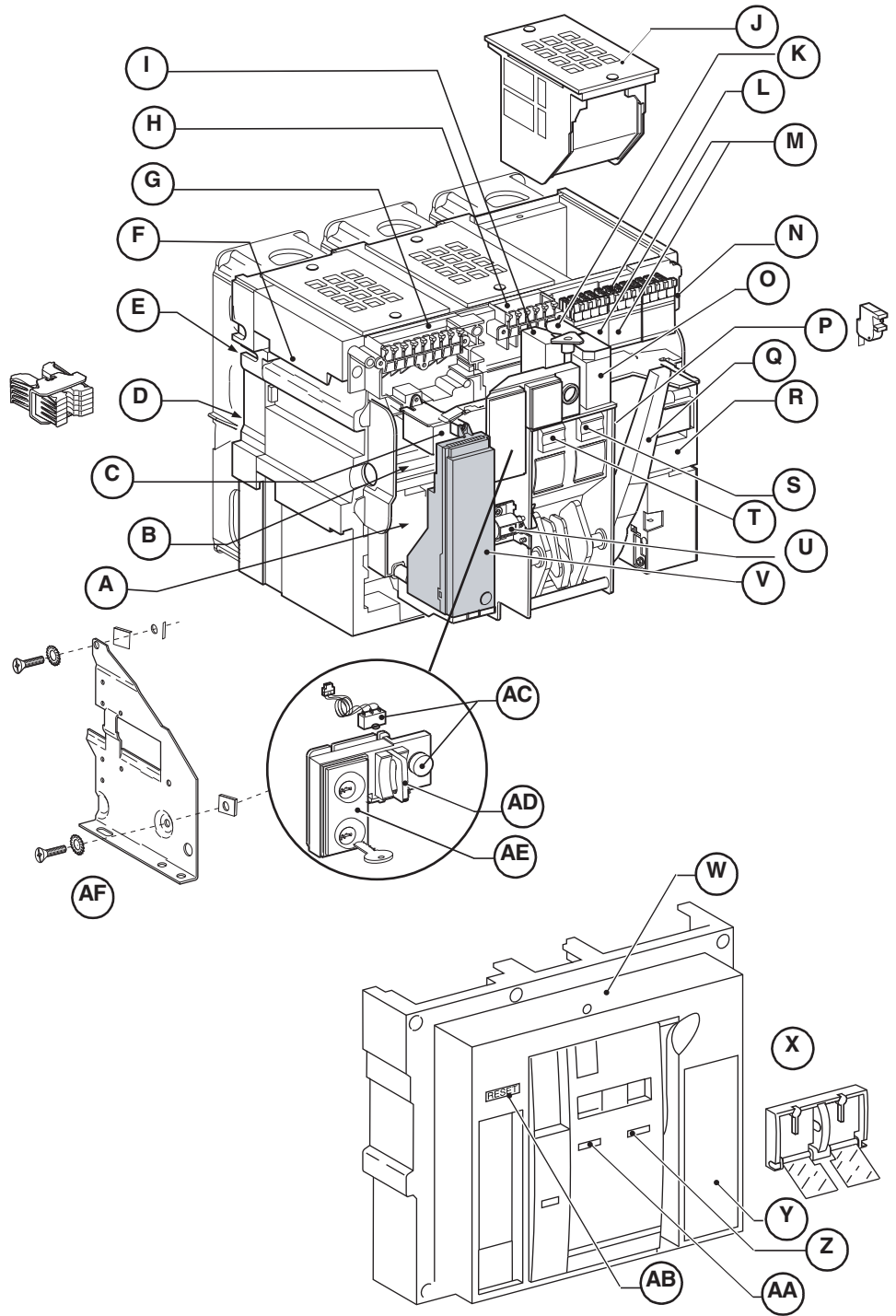

**Masterpact™ NT and NW Universal Power Circuit Breakers**  
**Masterpact™ Circuit Breakers**

**Masterpact NW Cradle Design**

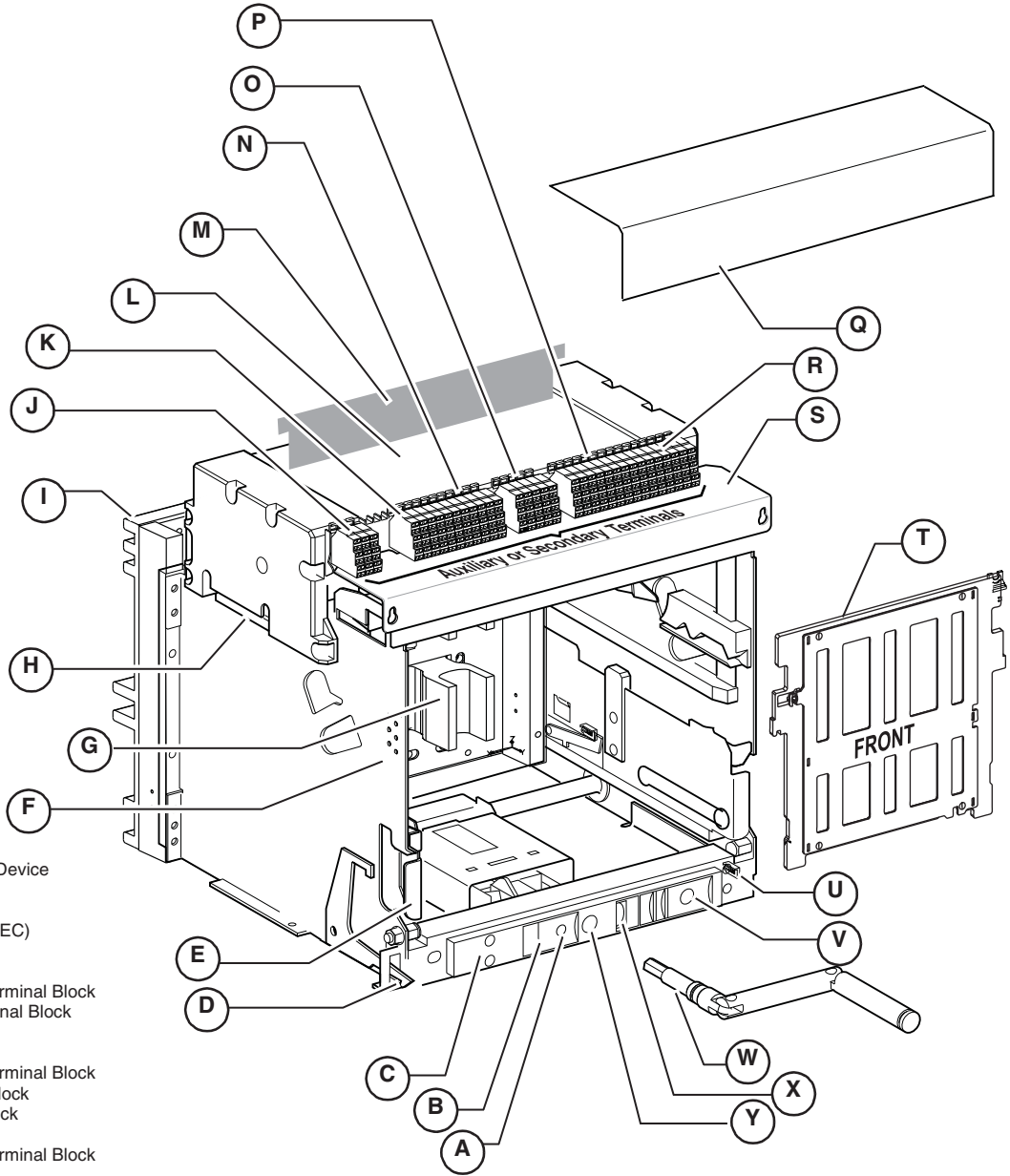

- A. Stop Release Button
- B. Padlock Provision
- C. Key Interlock
- D. Door Interlock for Connected Device
- E. Pull-Out Hand Grip
- F. Rejection Feature
- G. Primary Stabs (UL)/Clusters (IEC)
- H. Lifting Tab
- I. Cradle Back Mold
- J. Position Indicating Contact Terminal Block
- K. Overcurrent Trip Switch Terminal Block
- L. Arc Chamber Cover
- M. Tool Shield
- N. Position Indicating Contact Terminal Block
- O. Accessory Control Terminal Block
- P. Auxiliary Contact Terminal Block
- Q. Terminal Cover
- R. Position Indicating Contact Terminal Block
- S. Wiring Cover
- T. Shutter
- U. Racking Interlock for Open Door
- V. Crank Storage Space
- W. Racking Crank
- X. Position Indicator
- Y. Crank Insertion Opening

# Masterpact™ NT and NW Universal Power Circuit Breakers Masterpact™ Circuit Breakers

## Masterpact NW with ArcBlok™ Technology

The Masterpact NW low-voltage power circuit breaker and insulated case circuit breaker are available with ArcBlok technology designed to mount in an ArcBlok drawout cradle.

The Masterpact NW with ArcBlok technology interfaces with the ArcBlok cradle to prevent arcing events by enclosing the phases at the primary connection of the cradle. If for any reason an arcing event happens, with the separation between phase to phase and phase to ground, the arc is extinguished in less than 12 ms to reduce arc flash energy.

The Masterpact NW with ArcBlok technology is tested as part of Arc Resistant Equipment to ANSI C37.20.7.

**Figure 5: Masterpact NW Circuit Breaker and Cradle with ArcBlok Technology**

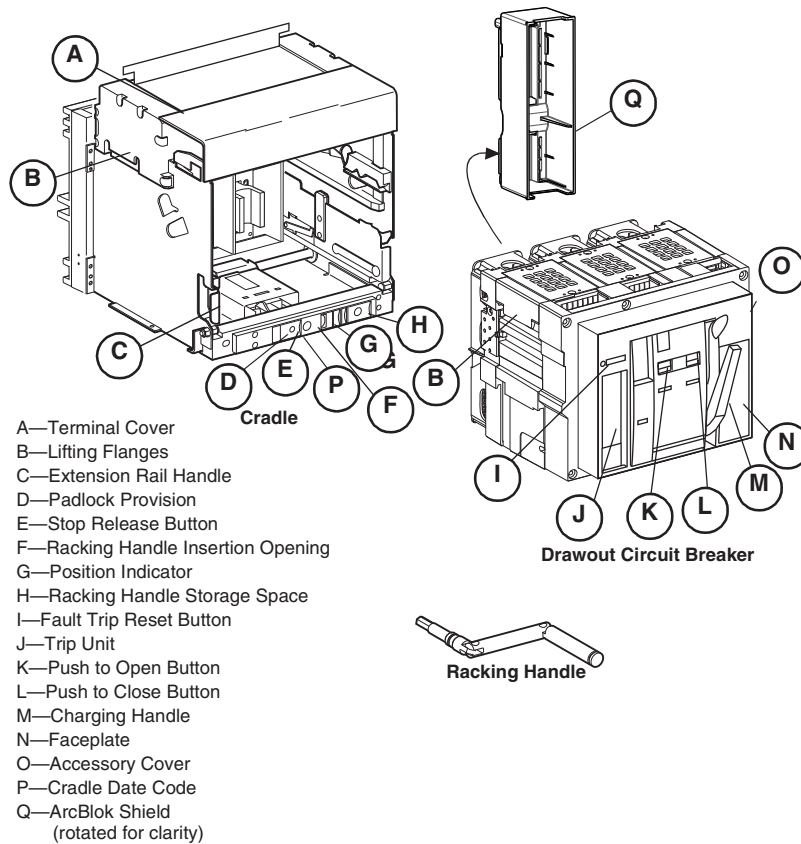

**Masterpact™ NT and NW Universal Power Circuit Breakers**  
**Masterpact™ Circuit Breakers**

**Masterpact NT Circuit Breaker and Cradle Design**

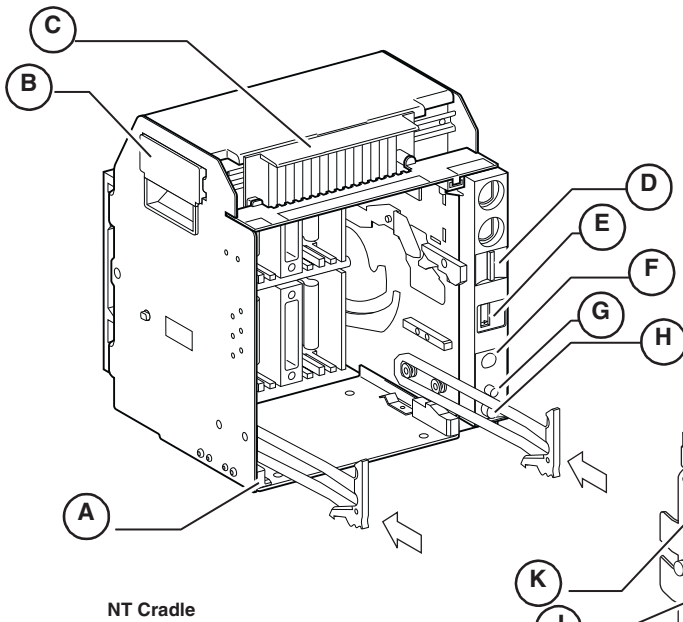

**NT Cradle**

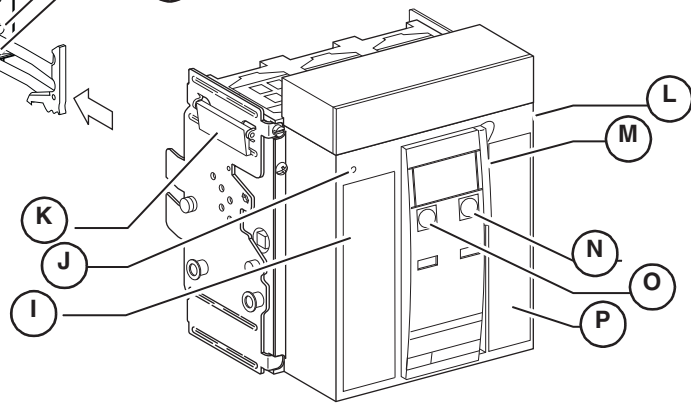

**NT Drawout Circuit Breaker**

- A. Extension Rail Handle
- B. Lifting Handle
- C. Terminal Cover
- D. Padlock Provision
- E. Position Indicator
- F. Racking Handle Insertion Opening
- G. Stop Release Button
- H. Racking Handle Storage Space
- I. Lifting Tab
- J. Fault Trip Reset Button
- K. Trip Unit
- L. Accessory Cover
- M. Charging Handle
- N. :Push-to-close" Button
- O. "Push-to-open" Button
- P. Faceplate
- Q.

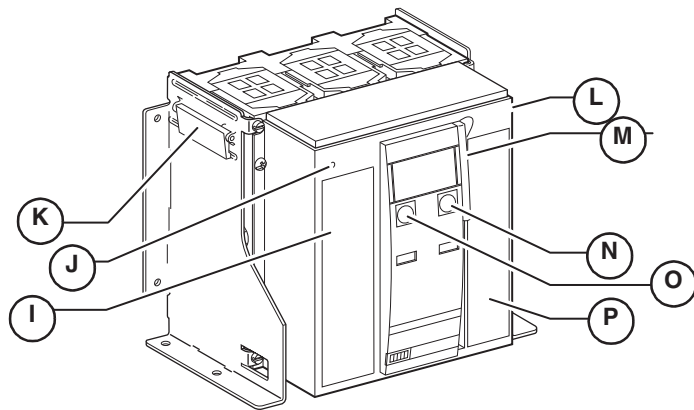

**NT Fixed Circuit Breaker**



# Masterpact™ NT and NW Universal Power Circuit Breakers Masterpact™ Circuit Breakers

## Ratings

**Table 1: Ratings for ANSI C37 Certified Masterpact NW Circuit Breakers**

Frame Rating		800/1600 A						2000 A					3200/4000 A <sup>1</sup>				4000/5000/6000 A <sup>2</sup>		
Interrupting Rating Code		N1	H1	H2	H3	L1 <sup>3, 4</sup>	L1F <sup>4</sup>	H1	H2	H3	L1 <sup>3, 4</sup>	L1F <sup>4</sup>	H1	H2	H3	L1 <sup>3, 4</sup>	H2	H3	L1 <sup>3, 4</sup>
Interrupting Current (kAIR)	254 Vac 50/60 Hz	42	65	85	100	200	200	65	85	100	200	200	65	85	100	200	85	100	200
	508 Vac 50/60 Hz	42	65	85	100	200	200	65	85	100	200	200	65	85	100	200	85	100	200
	635 Vac 50/60 Hz	42	65	85	85	130	130	65	85	85	130	130	65	85	85	130	85	85	130
Short-Time Withstand Current (kA)	Vac 50/60 Hz, 0.5 s	42	65	85	85	30	22	65	85	85	30	22	65	85	85	100	85	85	100
Built In Instantaneous Override (Peak kA ±10%)		— <sup>5</sup>	— <sup>5</sup>	— <sup>5</sup>	190	80 <sup>5</sup>	55	—	—	190	80	55	—	—	190	270	—	—	270
Close and Latch Ratings (Peak kA)	Vac 50/60 Hz	90	150	90	90	55	50	150	90	90	55	50	150	90	90	90	170	170	90
Tested to show arc flash hazard risk category as referenced by NFPA70E		—	—	—	—	—	Yes	—	—	—	—	Yes	—	—	—	—	—	—	—
Breaking Time		25 to 30 ms (with no intentional delay) 9 ms for L1 and L1F																	
Closing Time		70 ms																	
Sensor Rating		100–800 A 800–1600 A						1000–2000 A					1600–4000 A				2000–4000 A 2500–5000 A 3000–6000 A		
Endurance Rating (C/O Cycles) (with no maintenance)	Mechanical	12,500						10,000					10,000				5000		
	Electrical	2800						1000					1000				1000		

- <sup>1</sup> 4000 A standard width circuit breaker is not available in L1 interrupting rating code or drawout construction.
- <sup>2</sup> ArcBlok circuit breakers are available only to 5000 A.
- <sup>3</sup> Interrupting ratings (kAIR) at 50 Hz: 200 kA (254 Vac), 150 kA (508 Vac), 100 kA (635 Vac).
- <sup>4</sup> The interrupting ratings L1 and L1F are available only in 3P, drawout construction.
- <sup>5</sup> 55 kA for 800 A circuit breaker frame with 100 A or 250 A sensor.

**Table 2: Ratings for ANSI C37 Certified Masterpact NW Non-Automatic Switches**

Frame Rating		800 A		1600 A		2000 A		3200 A		4000 A		5000 A	
Withstand Rating Code		HA		HA		HA		HA		HA		HA	
Breaking Capacity with External Relay (kA), 50/60 Hz	254 Vac	65		65		65		65		85		85	
	508 Vac	65		65		65		65		85		85	
	635 Vac	65		65		65		65		85		85	
Short-Time Withstand Current (kA) Vac 50/60 Hz, 0.5 s		65		65		65		65		85		85	

**Table 3: Ratings for ANSI C37 Certified Masterpact NW Automatic Switches**

Frame Rating		800 A		1600 A		2000 A		3200 A		4000 A <sup>1</sup>		5000 A	
Withstand Rating Code		HF	HC	HF	HC	HF	HC	HF	HC	HF	HC	HF	HC
Breaking Capacity with External Relay (kA), 50/60 Hz	254 Vac	100	200	100	200	100	200	100	200	100	200	100	200
	508 Vac	100	200	100	200	100	200	100	200	100	200	100	200
	635 Vac	85	130	85	130	85	130	85	130	85	130	85	130
Short-Time Withstand Current (kA) 50/60 Hz, 1.5 s		85	30	85	30	85	30	85	100	85	100	85	100

- <sup>1</sup> 4000 A standard width automatic switch is not available in HC withstand rating code or drawout construction.

# Masterpact™ NT and NW Universal Power Circuit Breakers

## Masterpact™ Circuit Breakers

**Table 4: Ratings for UL 489 Listed Masterpact NW Circuit Breakers**

Frame Rating		800/1200/1600/2000 A				2500/3000 A		4000/5000/6000 A	
Interrupting Rating Code		N	H	L	LF	H	L	H	L
Interrupting Current (kAIR)	240 Vac 50/60 Hz	65	100	200	200	100	200	100	200
	480 Vac 50/60 Hz	65	100	150	150	100	150	100	150
	600 Vac 50/60 Hz	50	85	100	100	85	100	85	100
Short-Time Withstand Current (kA)	Vac 50/60 Hz, 0.5 s	42 <sup>1</sup>	65 <sup>1</sup>	30 <sup>1, 2</sup>	22	65	65	85	100
Built-In Instantaneous Override (Peak kA ±10%)		90	90	80 <sup>3, 4</sup>	55	150	150	170	170
Close and Latch Ratings (Peak kA)	Vac 50/60 Hz	90	90	55 <sup>5</sup>	50	90	90	90	90
Tested to show arc flash hazard risk category as referenced by NFPA70E		—	—	—	Yes	—	—	—	—
Breaking Time		25 to 30 ms (with no intentional delay) 9 ms for L and LF							
Closing Time		70 ms							
Sensor Rating		100–250 A / 400–800 A / 600–1200 A / 800–1600 A / 1000–2000 A				1200–2500 A / 1600–3000 A		2000–4000 A / 2500–5000 A / 3000–6000 A	
Endurance Rating (C/O Cycles) (with no maintenance)	Mechanical	12,500 <sup>6</sup>	12,500 <sup>6</sup>	12,500 <sup>6</sup>	12,500 <sup>6</sup>	10,000	10,000	5000	5000
	Electrical	2800 <sup>6</sup>	2800 <sup>6</sup>	2800 <sup>6</sup>	2800 <sup>6</sup>	1000	1000	1000	1000

- <sup>1</sup> 24 kA for 800 A circuit breaker frame with 100 A or 250 A sensor.
- <sup>2</sup> 65 kA for 2000 A.
- <sup>3</sup> 55 kA for 800 A circuit breaker frame with 100 A or 250 A sensor.
- <sup>4</sup> 150 kA for 200 A sensor.
- <sup>5</sup> 90 kA for 2000 A.
- <sup>6</sup> The endurance rating for 2000 A, N/H/L/LF is 10,000 for mechanical and 1000 for electrical.

**Table 5: Ratings for UL 489 Listed Masterpact NW Automatic Switches**

Frame Rating		800 A		1200 A		1600 A		2000 A		2500 A		3000 A		4000 A		5000 A		6000 A	
Withstand Rating Code		HF	HB	HF	HB	HF	HB	HF	HB	HF	HB	HF	HB	HF	HB	HF	HB	HF	HB
Withstand Ratings <sup>1</sup> (kA) Vac, 50/60 Hz	240	100	200	100	200	100	200	100	200	100	200	100	200	100	200	100	200	100	200
	480	100	150	100	150	100	150	100	150	100	150	100	150	100	150	100	150	100	150
	600	85	100	85	100	85	100	85	100	85	100	85	100	85	100	85	100	85	100
Instantaneous Override (Peak kA)		90	80	90	50	90	80	90	80	150	150	150	150	170	170	170	170	170	170

<sup>1</sup> The withstand rating is the fault current (at rated voltage) that the switch will withstand without damage when protected by a circuit breaker with an equal continuous current rating.

## Masterpact™ NT and NW Universal Power Circuit Breakers Masterpact™ Circuit Breakers

**Table 6: Ratings for IEC 60947-2 Rated Masterpact NW Circuit Breakers**

Frame Rating		800/1000/1250/1600 A					2000 A						2500/3200/4000 A				4000B/5000/6300 A		
Interrupting Rating Code		N1	H1	H2	L1	H10	N1	H1	H2	H3	L1	H10	H1	H2	H3	H10	H1	H2	
Ultimate Breaking Capacity (kA) 50/60 Hz	$I_{cu}$	220/415 Vac	42	65	100	150	—	42	65	100	150	150	—	65	100	150	—	100	150
		440 Vac	42	65	100	150	—	42	65	100	150	150	—	65	100	150	—	100	150
		525 Vac	42	65	85	130	—	42	65	85	130	130	—	65	85	130	—	100	130
		690 Vac	42	65	85	100	—	42	65	85	100	100	—	65	85	100	—	100	100
		1150 Vac	—	—	—	—	50	—	—	—	—	—	50	—	—	—	50	—	—
Service Breaking Capacity	$I_{cs}$	% $I_{cu}$	100%	100%	100%	100%	100%	100%	100%	100%	100%	100%	100%	100%	100%	100%	100%	100%	100%
Short-Time Withstand Current (kA)	$I_{cw}$	Vac 50/60 Hz, 1 s	42	65	85	30	50	42	65	85	65	30	50	65	85	65	50	100	100
		Vac 50/60 Hz, 3 s	22	36	50	30	50	22	36	75	65	30	50	65	75	65	50	100	100
Built-In Instantaneous Override (Peak kA ±10%)			—	—	190 <sup>1</sup>	80 <sup>1</sup>	—	—	—	190	150	80	—	—	190	150	—	—	117
Rated making Current (Peak kA) 50/60 Hz	$I_{cm}$	220/415 Vac	88	143	220	330	—	88	88	220	330	330	—	143	220	330	—	220	330
		440 Vac	88	143	220	330	—	88	88	220	330	330	—	143	220	330	—	220	330
		525 Vac	88	143	187	286	—	88	88	187	286	286	—	143	189	286	—	187	286
		690 Vac	88	143	187	220	—	88	88	187	220	220	—	143	189	220	—	187	220
		1150 Vac	—	—	—	—	105	—	—	—	—	—	105	—	—	—	105	—	—
Break Time	ms	25					25						25				25		
Closing Time	ms	< 70					< 70						< 70				< 80		
Endurance Rating (with no maint.) C/O Cycles x 1000	Mechanical	12.5					10						10				5		
	Electrical 440 V	10	10	10	3	—	8	8	8	3	3	—	5	5	1.25	—	1.5	1.5	
	Electrical 1150 V	—	—	—	—	0.5	—	—	—	—	—	0.5	—	—	—	0.5	—	—	

<sup>1</sup> 55 kA for 800 A circuit breaker frame with 100 A or 250 A sensor.

**Table 7: Ratings for IEC 60947-3 Rated Masterpact NW Switches**

Frame Rating		800/1000/1250/1600 A					2000 A			2500/3200/4000 A			4000B/5000/6300 A
Withstand Rating Code <sup>1</sup>		NA	HA	HF	HA10	HA	HF	HA10	HA	HF	HA10	HA	
Rated Making Current (Peak kA)	$I_{cm}$	220/415 Vac, 50/60 Hz	88	105	187	—	105	187	—	121	189	—	187
		440 Vac, 50/60 Hz	88	105	187	—	105	187	—	121	189	—	187
		500/690 Vac, 50/60 Hz	88	105	187	—	105	187	—	121	189	—	187
		1150 Vac, 50/60 Hz	—	—	—	105	—	—	105	121	—	105	—
Short-Time Withstand Current (kA)	$I_{cw}$	Vac 50/60 Hz, 1 s	42	50	85	50	50	85	50	50	85	50	85
Ultimate Breaking Capacity (with external protection relay) (kA)	$I_{cu}$	Maximum Delay 350 ms	42	50	85	50	50	85	50	50	85	50	85

<sup>1</sup> NA, HA, and HA10 are non-automatic switches; HF is an automatic switch.

# Masterpact™ NT and NW Universal Power Circuit Breakers

## Masterpact™ Circuit Breakers

**Table 8: Ratings for ANSI C37 Certified Masterpact NT Circuit Breakers**

Frame Rating	800 A	
Interrupting Rating Code	N1	
Interrupting Current (kAIR)	254 Vac 60 Hz	42
	508 Vac 60 Hz	42
	635 Vac 60 Hz	N/A
Short-Time Withstand Current (kA)	ac 60 Hz, 0.5 s	42
Built-In Instantaneous Override (Peak kA ±10%)	—	
Close and Latch Ratings (Peak kA)	ac 60 Hz	90
Tested to show arc flash hazard risk category as referenced by NFPA70E	—	
Breaking Time	25 to 30 ms (with no intentional time delay)	
Closing Time	< 50 ms	
Sensor Rating	100 to 250 A / 400 to 800 A	
Endurance Rating (C/O Cycles) (with no maintenance)	Mechanical	12,500
	Electrical	2800

**Table 9: Ratings for ANSI C37 Certified Masterpact NT Non-Automatic Switches**

Frame Rating	800 A	
Withstand Rating Code	NA	
Short-Time Withstand Current Rating (kA)	Vac 50/60 Hz, 0.5 s	42
Breaking Capacity (with external protection relay) (kA)	254/508/635 Vac, 60 Hz	42/42/NA

**Table 10: Ratings for UL 489 Listed Masterpact NT Circuit Breakers**

Frame Rating	800 A						1200 A					1600 A <sup>1</sup>				
	Interrupting Rating Code		N	H	L1	L	LF	N	H	L1	L	LF	N	H	L1	L
Interrupting Current (kAIR)	240 Vac, 60 Hz	50	65	100	200	200	50	65	100	200	200	50	65	100	200	
	480 Vac, 60 Hz	50	50	65	100	100	50	50	65	100	100	50	50	65	100	
	600 Vac, 60 Hz	35	50	N/A	N/A	N/A	35	50	N/A	N/A	N/A	35	50	N/A	N/A	
Short-Time Withstand Current Rating (kA)	Vac 60 Hz, 0.5 s	35	35	10	10	10	35	35	10	10	10	35	35	10	10	
Built-In Instantaneous Override (Peak kA ±10%)			90	90	22	22	22	90	90	22	22	22	90	90	22	22
Close and Latch Ratings (Peak kA)	Vac 60 Hz	55	55	22	22	22	55	55	22	22	22	55	55	22	22	
Tested to show arc flash hazard risk category as referenced by NFPA70E			—	—	—	—	Yes	—	—	—	—	Yes	—	—	—	—
Breaking Time			25 to 30 ms (with no intentional time delay) 9 ms for L and LF													
Closing Time			< 50 ms													
Sensor Rating			100–250 A / 400–800 A				600–1200 A				800–1600 A					
Endurance Rating (C/O Cycles) (with no maintenance)	Mechanical	12,500														
	Electrical	2800														

<sup>1</sup> Fixed-mounted only. 1600 A UL489 drawout circuit breakers are not available.

**Table 11: Ratings for UL 489 Listed Masterpact NT Automatic Switches**

Frame Rating	800 A				1200 A		1600 A	
	Withstand Rating Code		HF	HB	HF	HB	HF	HB
Withstand Rating <sup>1</sup> (kA) Vac, 50/60 Hz	240	65	200	65	200	65	200	
	480	50	100	50	100	50	100	
	600	50	NA	50	NA	50	NA	
Instantaneous Override (Peak kA)	90		22	90	22	90	22	

<sup>1</sup> The withstand rating is the fault current (at rated voltage) that the switch will withstand without damage when protected by a circuit breaker with an equal continuous current rating.

# Masterpact™ NT and NW Universal Power Circuit Breakers Masterpact™ Circuit Breakers

**Table 12: Ratings for IEC 60947-2 Rated Masterpact NT Circuit Breakers**

Frame Rating			800/1000 A			1250/1600 A	
Interrupting Rating Code			H1	H2	L1	H1	H2
Ultimate Breaking Capacity (kA)	$I_{cu}$	220/415 Vac, 50/60 Hz	42	50	150	42	50
		440 Vac, 50/60 Hz	42	50	130	42	50
		525 Vac, 50/60 Hz	42	42	100	42	42
		690 Vac, 50/60 Hz	42	42	25	42	42
		1000 Vac, 50/60 Hz	—	—	—	—	—
Service Breaking Capacity (kA)	$I_{cs}$	% $I_{cu}$	100%	100%	100%	100%	100%
Short-Time Withstand Current (kA)	$I_{cw}$	Vac 50/60 Hz, 1 s	42	42	10 x $I_n^1$	42	36
Built-In Instantaneous Override (kA ±10%)			—	90	10 <sup>2</sup>	—	—
Rated Making Capacity (Peak kA)	$I_{cm}$	220/415 Vac, 50/60 Hz	88	105	330	88	105
		440 Vac, 50/60 Hz	88	105	286	88	105
		525 Vac, 50/60 Hz	88	88	220	88	88
		690 Vac, 50/60 Hz	88	88	52	88	88
		1000 Vac, 50/60 Hz	—	—	—	—	—
Break Time	ms		25	25	9	25	25
Closing Time	ms		50	50	50	50	50
Endurance Rating (C/O cycles) (with no maintenance)	Mechanical		12,500	12,500	12,500	12,500	12,500
	Electrical 440 V		6000	6000	3000	6000 <sup>3</sup>	6000 <sup>3</sup>
	Electrical 1000 V		—	—	—	—	—

<sup>1</sup> For  $I_{cw}$ , 10 kA is for 0.5 s.

<sup>2</sup> SELLIM system.

<sup>3</sup> 1600 A at 690 V is 3000 electrical operations.

**Table 13: Ratings for IEC 60947-3 Rated Non-Automatic Masterpact NT Switches**

Frame Rating			800/1000 A	1250/1600 A
Withstand Rating Code			HA	HA
Rated Making Capacity (Peak kA)	$I_{cm}$	220/415 Vac, 50/60 Hz	75	75
		440 Vac, 50/60 Hz	75	75
		500/690 Vac, 50/60 Hz	75	75
		1000 Vac, 50/60 Hz	—	—
Short-Time Withstand Current (kA)	$I_{cw}$	Vac 50/60 Hz, 0.5 s	36	36
Breaking Capacity (kA at 690 Vac) (with external protection relay)	$I_{cu}$	maximum delay 350 ms	36	36

## Correction Factors

**Table 14: Temperature Correction Factors**

Maximum Ambient Temperature													
°F	158	140	122	104	86	77	68	50	32	14	-4	-13	-22
°C	70	60	50	40	30	25	20	10	0	-10	-20	-25	-30
Current	0.75	0.83	0.92	1.00	1.07	1.11	1.14	1.21	1.27	1.33	1.39	1.42	1.44

**Table 15: Altitude Correction Factors per ANSI C37.20.1 par. 7.1.4.1 (Table 10)**

	< 6600 ft. (2000 m)	8500 ft (2600 m)	13,000 ft. (3900 m)
Voltage	1.00	0.95	0.80
Current	1.00	0.99	0.96

**Masterpact™ NT and NW Universal Power Circuit Breakers**  
**Masterpact™ Circuit Breakers**

**Shipping Weights**

**Table 16: Shipping Weights for UL Listed/ANSI Certified Masterpact NW Circuit Breakers**

Circuit Breaker Rating (A)	Circuit Breaker <sup>1</sup> (lb/kg)		Cradle (lb/kg)		Connector Type and Weight (lb/kg)			Pallet (lb/kg)	Total Weight (lb/kg)	
	3P	4P	3P	4P	Type	3P	4P		3P	4P
800					FCF	42/19	55/25	17/8	265/121	320/151
1600	109/50	142/65	97/44	116/53	FCT	84/38	109/50	17/8	307/140	384/176
2000					RCTH or RCTV	17/8	22/10	17/8	240/110	297/136
2500					FCT	80/36	104/47	17/8	348/159	435/198
3000	127/58	165/75	124/57	149/68	RCTH or RCTV	26/12	34/15	17/8	294/135	365/166
2000 (L1, L1F)	127/58	165/75	124/57	149/68	RCOV (standard)	100/46	130/59	17/8	368/169	461/210
3200 (H1, H2, H3)					RCOV (ArcBlok)	153/69	NA		421/191	NA
4000 W-Frame (H1, H2, H3)					RCOV (special)	115/52	145/66		259/118	327/149
3200 (L1)	227/103	295/134	278/126	334/152	FCF	84/38	109/50	39/18	628/285	777/354
4000					FCT	168/77	218/99	39/18	712/324	886/403
					RCTH or RCTV	52/24	68/31	39/18	596/271	736/335
5000	227/103	295/134	278/126	334/152	FCT	168/77	218/99	39/18	712/324	886/403
					RCTH or RCTV	52/24	68/31	39/18	596/271	736/335
6000	227/103	295/134	278/126	334/152	RCTH or RCTV	396/180	528/240	39/18	940/427	1196/544

<sup>1</sup> Fixed circuit breaker weight = total weight – cradle weight.

**Table 17: Shipping Weights for IEC 60947-2 Rated Masterpact NW Circuit Breakers**

Circuit Breaker Rating (A)	Circuit Breaker <sup>1</sup> (lb/kg)		Cradle (lb/kg)		Connector Type and Weight (lb/kg)			Pallet (lb/kg)	Total Weight (lb/kg)	
	3P	4P	3P	4P	Type	3P	4P		3P	4P
800					FCF	42/19	55/25	17/8	265/121	320/145
1000, 1250, 1600, 2000	109/50	132/60	97/44	116/53	RCTH or RCTV	17/8	22/10	17/8	240/110	287/131
2500					FCF	42/19	55/25	17/8	310/142	386/175
3200	127/58	165/75	124/57	149/68	RCTH or RCTV	17/8	22/10	17/8	285/131	353/161
4000	127/58	165/75	124/57	149/68	RCTH or RCTV	42/19	55/25	17/8	310/142	386/176
4000b, 5000, 6300	227/103	295/134	278/126	334/152	RCTH or RCTV	52/24	68/31	39/18	596/271	736/335

<sup>1</sup> Fixed circuit breaker weight = total weight – cradle weight.

**Table 18: Shipping Weights for UL Listed/ANSI Certified Masterpact NT Circuit Breakers**

Circuit Breaker Rating (A)	Circuit Breaker <sup>1</sup> (lb/kg)		Cradle (lb/kg)		Connector Type and Weight (lb/kg)			Pallet (lb/kg)	Total Weight (lb/kg)	
	3P	4P	3P	4P	Type	3P	4P		3P	4P
800					FCF	15/7	20/9	10/5	101/46	125/58
1200	40/18	52/24	36/16	43/20	RCTH or RCTV	6/3	8/4	10/5	92/42	113/53
1600 <sup>2</sup>	40/18	52/24	N/A	N/A	RCTV	18/8	20/9	10/5	68/31	82/38

<sup>1</sup> Fixed circuit breaker weight = total weight – cradle weight.

<sup>2</sup> Fixed circuit breaker only.

**Table 19: Shipping Weights for IEC 60947-2 Rated Masterpact NT Circuit Breakers**

Circuit Breaker Rating (A)	Circuit Breaker <sup>1</sup> (lb/kg)		Cradle (lb/kg)		Connector Type and Weight (lb/kg)			Pallet (lb/kg)	Total Weight (lb/kg)	
	3P	4P	3P	4P	Type	3P	4P		3P	4P
800					FCF	15/7	20/9	10/5	91/41	113/52
1000, 1250, 1600	35/16	46/21	31/14	37/17	RCTH or RCTV	6/3	8/4	10/5	82/38	101/47

<sup>1</sup> Fixed circuit breaker weight = total weight – cradle weight.

## Section 2—Energy Management

Energy Management has Never Been Simpler .....	14
Measure .....	15
Connect .....	15
Save .....	15
Enerlin'X Communication System Components .....	16
Masterpact Circuit Breakers with Micrologic Trip Units .....	16
Power Meter Functions .....	17
Display Function .....	17
Measurement Function .....	18
Instantaneous RMS Measurements .....	18
Maximum / Minimum Ammeter .....	18
Energy Metering .....	18
Demand and Maximum Demand Values .....	18
Power Quality .....	18
Histories .....	20
Maintenance Indicators .....	20
Contact Wear .....	20
Circuit Breaker Load Profile .....	20
Management of Installed Devices .....	21
FDM121 Display .....	22
Display of Micrologic Trip Unit Measurements and Alarms .....	22
Status Indications and Remote Control .....	23
Main Characteristics .....	23
Mounting .....	23
Connection .....	24
Navigation .....	24
Screens .....	24
Communication Components and FDM121 Connections .....	25
FDM128 Display .....	26
Display of Micrologic Trip Unit Measurements and Trips .....	26
Status Indications .....	26
Remote Control .....	26
Main Characteristics .....	27
Mounting .....	27
Connection .....	27
Navigation .....	27
Screens .....	27
Communication Components and FDM128 Connections .....	28

## Energy Management Using the Enerlin'X System

Use the Enerlin'X communication system to connect a building to real savings in three steps:

- A. Measure
  - Embedded and stand-alone metering and control
- B. Connect
  - Integrated communication interfaces
  - Ready to connect to energy management platforms
- C. Save
  - Data-driven energy efficiency actions
  - Real-time monitoring and control
  - Access to energy and site information through on-line services





# Masterpact™ NT and NW Universal Power Circuit Breakers

## Energy Management

### Measure

Enerlin'X communication systems mean visible information.

Grouping most of the electrical protection, command and metering components, the switchboards are now significant sources of data locally displayed and sent via communication networks.

### Connect

Enerlin'X communication systems use reliable, simple-to-install-and-use displays, and Ethernet and Modbus interfaces.

Information is safely transmitted through the most efficient networks:

- Modbus SL inside switchboards, between components,
- Ethernet, on cable or WiFi, inside the building and connecting switchboards and computers,
- Ethernet or GPRS, for access to on-line services by Schneider Electric.

Energy experts, no matter where they are located, can now provide advise based on the updated data of the building.

### Save



#### On-Site Real-Time Monitoring and Control

The FDM128 touch screen display connected to the Ethernet:

- shows essential electrical information and alarms concerning the electrical network,
- allows control (open, close, reset...) of various equipment.

The FDM128 touch screen provides real-time value checking and control, directly on the front panel of the main switchboard.

On a PC display with common browser:

- shows monitoring web pages hosted into the local Ethernet interface,
- alarm events generate automatic email notifications,
- allows control (open, close, reset...) of various equipment.

The data is displayed graphically or recorded into files for optimizing the use of energy in the building.

As an example, the data can help validate the change of temperature settings, time scheduling in a Building Management System or other automated devices.

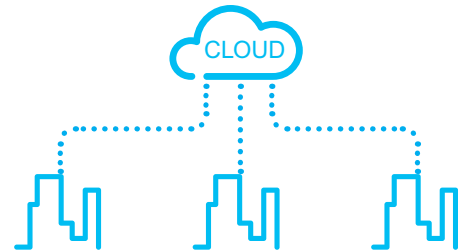

#### On-Line Energy Management Services

StruXureWare Energy Operation automates data collection using an open, scalable, and secure energy management information system.

With the help of the Schneider Electric energy management services team, data is turned into information to enable customers to understand their facilities' performance on an ongoing basis.

Energy Operation leverages companies' current investments in their existing systems, and can be used to communicate advanced results and performance to a broad audience for a shared understanding throughout an organization.

# Masterpact™ NT and NW Universal Power Circuit Breakers Energy Management

## Enerlin'X Communication System Components

### Masterpact Circuit Breakers with Micrologic Trip Units

#### Ammeter A

- 3.0 basic protection
- 5.0 selective protection
- 6.0 selective + ground-fault protection

#### Power Meter P

- 5.0 selective protection
- 6.0 selective + ground-fault protection

#### Harmonic Meter H

- 5.0 selective protection
- 6.0 selective + ground-fault protection

See page 43 for more information.



Power Meter

## Displays

### FDM121

- One-to-one front display module
- See page 23 for more information



Operating Assistance  
Functions

### FDM128

- One-to-eight front display module
- See page 23 for more information



Communication

## Communication

- Masterpact circuit breakers in a communication network
- I/O application module
- IFE: Ethernet interface module
- IFM: Modbus interface module



I/O Module



IFE Module



IFM Module

See page 46 for more information.

# Masterpact™ NT and NW Universal Power Circuit Breakers Energy Management

## Power Meter Functions

In addition to protection functions, Micrologic A/P/H trip units offer all the functions of Power Meter products as well as operating assistance for the circuit breaker.

Micrologic A/P/H trip unit measurement functions are made possible by the Micrologic trip unit's intelligence and the accuracy of the sensors. They are handled by a microprocessor that operates independent of protection functions.

## Display Function



Display Function

### FDM121 Display Unit (One to One)

The FDM121 switchboard display unit can be connected to a communication (COM) option (Breaker Communication Module [BCM ULP]) using a circuit breaker ULP cord to display all measurements on a screen. The LCD screen is 3.78 x 3.78 in. (96 x 96 mm). The FMD121 display unit requires a 24 Vdc power supply. The COM option (BCM ULP) unit is supplied by the same power supply via the circuit breaker ULP cord connecting it to the FDM121. See page 28 for more information.

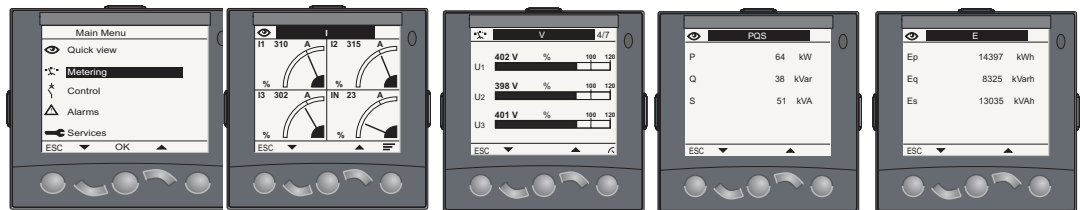

FDM121 Display Navigation

FDM121 Display Current

FDM121 Display: Voltage

FDM121 Display: Power

FDM121 Display: Consumption

### FDM128 Display Unit (One to Eight)

The FDM128 display unit uses an IFE Ethernet interface for low-voltage circuit breakers.



FDM128 Display Navigation

FDM128 Display Current

FDM128 Display: Voltage

FDM128 Display: Power

FDM128 Display: Consumption

For all FDM, in addition to the information displayed on the Micrologic trip unit LCD, the FDM screen shows demand, power quality, and maximum/minimum ammeter values along with histories and maintenance indicators.



Measurement Function

### Measurement Function

#### Instantaneous RMS Measurements

The Micrologic trip unit continuously displays the RMS value of the highest current of the three phases and neutral ( $I_{max}$ ). The navigation buttons can be used to scroll through the main measurements.

In the event of a fault trip, the trip cause is displayed.

The Micrologic A trip unit measures phase, neutral, and ground fault currents.

Micrologic P/H trip units offer voltage, power, power factor, frequency, and  $\cos \phi$  in addition to the measurements provided by Micrologic A trip units.

#### Maximum / Minimum Ammeter

Every instantaneous measurement provided by Micrologic A trip units can be associated with a maximum/minimum ammeter. The maximum for the highest current of the three phases, neutral, and demand current can be reset using the FDM display unit or the communication system.

#### Energy Metering

The Micrologic P/H trip units also measures the energy consumed since the last reset of the meter. The active energy meter can be reset using the Micrologic trip unit keypad, the FDM display unit, or the communication system.

#### Demand and Maximum Demand Values

Micrologic P/H trip units also calculate demand current and power values. These calculations can be made using a block or sliding interval that can be set from five to sixty minutes in steps of one minute. The window can be synchronised with a signal sent through the communication system. Whatever the calculation method, the calculated values can be recovered on a PC through the communication network.

Ordinary spreadsheet software can be used to provide trend curves and forecasts based on this data. They provide a basis for load shedding and reconnection operations used to adjust consumption to the subscribed power.

#### Power Quality

The Micrologic H trip unit calculates power quality indicators taking into account the presence of harmonics up to the fifteenth harmonic, including the total harmonic distortion (THD) of current and voltage.

# Masterpact™ NT and NW Universal Power Circuit Breakers Energy Management



**Table 20: Micrologic A/P/H Trip Units Integrated Power Meter Functions**

Micrologic A/P/H Integrated Power Meter Functions			Type	Display	
				Micrologic LCD	FDM Display
Display of protection settings					
Pick-ups (A) and delays	All settings can be displayed	$I_r, t_r, I_{sd}, t_{sd}, I_i, I_g, t_g$	A/P/H	X	—
Measurements					
Instantaneous rms measurements					
Currents (A)	Phases and neutral	$I_A, I_B, I_C, I_N$	A/P/H	X	X
	Average of phases	$I_{avg} = (I_A + I_B + I_C) / 3$	A/P/H	—	X
	Highest current of the 3 phases and neutral	$I_{max}$ of $I_A, I_B, I_C, I_N$	A/P/H	X	X
	Ground fault (Micrologic 6)	% $I_g$ (pick-up setting)	A/P/H	X	X
	Current unbalance between phases	% $I_{avg}$	P/H	—	X
Voltages (V)	Phase-to-phase	$V_{AB}, V_{BC}, V_{CA}$	P/H	X	X
	Phase-to-neutral	$V_{AN}, V_{BN}, V_{CN}$	P/H	X	X
	Average of phase-to-phase voltages	$V_{avg} = (V_{AB} + V_{BC} + V_{CA}) / 3$	P/H	—	X
	Average of phase-to-neutral voltages	$V_{avg} = (V_{AN} + V_{BN} + V_{CN}) / 3$	P/H	—	X
	Ph-Ph and Ph-N voltage unbalance	% $V_{avg}$	P/H	—	X
	Phase sequence	ABC, ACB	P/H	X	X <sup>1</sup>
Frequency (Hz)	Power system	$f$	P/H	X	X
Power	Active (kW)	P, total	P/H	X	X
		P, per phase	P/H	X	X
	Reactive (kVAR)	Q, total	P/H	X	X
		Q, per phase	P/H	X	X
	Apparent (kVA)	S, total	P/H	X	X
		S, per phase	P/H	X	X
Power Factor	PF, total	P/H	X	X	
	PF, per phase	P/H	X	X	
os $\phi$	Cos $\phi$ , total	P/H	X	X	
	Cos $\phi$ , per phase	P/H	X	X	
Maximum/Minimum Ammeter	Associated with instantaneous rms measurements	Reset using the FDM display unit and Micrologic keypad	A/P/H	X	X
Energy Metering					
Energy	Energy Active (kW), reactive (kVARh), apparent (kVAh)	Total since last reset	P/H	X	X
Demand and Maximum Demand Values					
Demand Current (A)	Phases and neutral P	Present value on the selected window	P/H	X	X
		Maximum demand since last reset	P/H	X	X
Demand Power	Active (kWh), reactive (kVAR), apparent (kVA)	Present value on the selected window	P/H	X	X
		Maximum demand since last reset	P/H	X	X
Calculation Window	Sliding, fixed or com-synchronised	Adjustable from 5 to 60 minutes in 1 minute steps <sup>2</sup>	P/H	—	—
Power Quality					
Total Harmonic Distortion (%)	Of voltage with respect to rms value	THDU, THDV of the Ph-Ph and Ph-N voltage	H	X	X
	Of current with respect to rms value	THDI of the phase current	H	X	X

<sup>1</sup> FDM121 only.

<sup>2</sup> Available via the communication system only.

### Histories



- Trip indications in clear text in a number of user-selectable languages
- Time-stamping: date and time of trip.

### Maintenance Indicators



Micrologic trip units have indicators for, among other items, the number of operating cycles, contact wear P/H, load profile and operating times (operating hours counter) of the Masterpact circuit breaker.

It is possible to assign an alarm to the operating cycle counter to plan maintenance.

The various indicators can be used together with the trip histories to analyze the level of stresses the device has been subjected to.

### Contact Wear

Each time a Masterpact circuit breaker opens, the Micrologic P/H trip unit measures the interrupted current and increments the contact-wear indicator as a function of the interrupted current, according to test results stored in memory. Breaking under normal load conditions results in a very slight increment. The indicator value may be read on the FDM display.

It provides an estimation of contact wear calculated on the basis of the cumulative forces affecting the circuit breaker. When the indicator reaches 100%, it is advised to visually inspect the contacts per the instructions in the circuit breaker user guide.

### Circuit Breaker Load Profile

Micrologic A/P/H trip units calculate the load profile of the circuit breaker protecting a load circuit. The profile indicates the percentage of the total operating time at four current levels (% of circuit breaker  $I_n$ ):

- 0 to 49%  $I_n$
- 50 to 79%  $I_n$
- 80 to 89%  $I_n$
- $\geq 90\%$   $I_n$ .

This information can be used to optimize use of the protected equipment or to plan ahead for maintenance interval extensions.

## Management of Installed Devices

Each circuit breaker equipped with a COM option (BCM ULP) can be identified using the communication system:

- serial number
- firmware version
- hardware version
- device name assigned by the user.

This information together with the previously described indications provides a clear description of the installed devices.



**Table 21: Micrologic A/P/H Trip Units Operating Assistance Functions**

Micrologic A/P/H Operating Assistance Functions			Type	Display	
				Micrologic LCD	FDM Display
Operating Assistance					
Trip History					
Trips	Cause of tripping	I <sub>r</sub> , I <sub>sd</sub> , I <sub>i</sub> , I <sub>g</sub> , I <sub>Dn</sub>	A/P/H	X	X
Maintenance Indicators					
Counter	Mechanical cycles	Assignable to an alarm	A/P/H	—	X
	Electrical cycles	Assignable to an alarm	A/P/H	—	X
	Hours	Total operating time (hours) <sup>1</sup>	A/P/H	—	—
Indicator	Contact wear	%	P/H	X	X
Load Profile	Hours at different load levels	% of hours in four current ranges: 0-49% I <sub>n</sub> , 50-79% I <sub>n</sub> , 80-89% I <sub>n</sub> and ≥ 90% I <sub>n</sub>	P/H	—	X

<sup>1</sup> Available through the communication system only.

# Masterpact™ NT and NW Universal Power Circuit Breakers

## Energy Management

### FDM121 Display

Micrologic trip unit measurement capabilities come into full play with the FDM121 display. It connects to the COM option (BCM ULP) with a circuit breaker ULP cord and displays the Micrologic trip unit information. The result is a true integrated unit combining a circuit breaker and a power meter. Additional operating assistance functions can also be displayed.

An FDM121 display unit can be connected to ULP communication devices using a prefabricated cord to display all measurements, alarms, histories and event tables, maintenance indicators, and management of installed devices on a screen.

The FDM121 display unit requires a 24 Vdc power supply.

The FDM121 is a display that can be integrated with the PowerPact H/J/L/P/R or Masterpact NT circuit breaker systems. It uses the sensors and processing capacity of the Micrologic trip unit. It is easy to use and requires no special software or settings. It is immediately operational when connected to the circuit breaker by a ULP cord.

It also provides monitoring and control with the use of the I/O application module, the motor mechanism module, or the circuit breaker communication module (BCM ULP).

The FDM121 has a large display, but requires very little depth. The anti-glare graphic screen is backlit for very easy reading even under poor ambient lighting and at sharp angles.

### Display of Micrologic Trip Unit Measurements and Alarms

The FDM121 is intended to display Micrologic trip unit measurements, alarms and operating information. It cannot be used to modify the protection settings.

Measurements can be easily accessed using a menu. All user-defined alarms are automatically displayed. The display mode depends on the priority level selected during alarm set-up:

- high priority: a pop-up window displays the time-stamped description of the alarm and the orange Alarm LED flashes;
- medium priority: the orange Alarm LED goes continuously on;
- low priority: no display on the screen.

All faults resulting in a trip automatically produce a high-priority alarm, without any special settings required. In all cases, the alarm history is updated. The Micrologic trip unit saves the information in its non-volatile memory in the event of an FDM121 power loss.



# Masterpact™ NT and NW Universal Power Circuit Breakers Energy Management

## Status Indications and Remote Control

When the circuit breaker is equipped with the Breaker Communications Module (BCM ULP), the FDM121 display can also be used to view circuit breaker status conditions:

- O/F: ON/OFF
- SD: trip indication
- SDE: fault-trip indication (overload, short-circuit, or ground fault).

When the circuit breaker system is equipped with the I/O application module, the FDM121 can monitor and control:

- cradle management
- circuit breaker operation
- light and load control
- custom applications.

When the circuit breaker is equipped with the COM option (BCM ULP) (including connection to shunt close [XF] and shunt trip [MX1] communication voltage releases), the FDM121 display can also be used to control (open/close) the circuit breaker.

Two operating mode are available:

- local mode: open/close commands are enabled from the FDM121 while disabled from the communication network;
- remote mode: open/close commands are disabled from the FDM121 while enabled from the communication network.

## Main Characteristics

- A 3.78 x 3.78 x 1.18 in. (96 x 96 x 30 mm) screen requiring 0.39 in. (10 mm) behind the door (or 0.79 in. [20 mm] when the 24 V power supply connector is used).
- White backlighting.
- Wide viewing angle: vertical  $\pm 60^\circ$ , horizontal  $\pm 30^\circ$ .
- High resolution: excellent reading of graphic symbols.
- Alarm LED: flashing orange for alarm pick-up, steady orange after operator reset if the alarm condition persists.
- Operating temperature range: +14 °F (-10 °C) to +131 °F (+55 °C).
- CE / UL / CSA marking.
- 24 Vdc power supply, with tolerances 24 V -20% (19.2 V) to 24 V +10% (26.4 V).

When the FDM121 is connected to the communication network, the 24 Vdc can be supplied by the communication system wiring system. Consumption is 40 mA.

## Mounting

The FDM121 is easily installed in a switchboard.

- Standard door cut-out is 3.6 x 3.6 in. (92 x 92 mm).
- Attached using clips.

To avoid a cut-out in the door, an accessory is available for surface mounting by drilling only two 0.87 in. (22 mm) diameter holes.



FDM121 Display



Surface Mount  
Accessory



Connection with FDM121  
Display Unit

# Masterpact™ NT and NW Universal Power Circuit Breakers

## Energy Management

### Connection

The FDM121 is equipped with a 24 Vdc terminal block:

- A plug-in type terminal block with two wire inputs per point for easy daisy-chaining.
- A power supply range of 24 Vdc -20% (19.2 V) to 24 Vdc +10% (26.4 V).  
A 24 Vdc type auxiliary power supply must be connected to a single point on the ULP system. The FDM121 display has a two-point screw connector on the rear panel of the module for this purpose. The ULP module to which the auxiliary power supply is connected distributes the supply via the ULP cable to all the ULP modules connected to the system and therefore also to Micrologic trip unit. See wiring diagram later in this section.
- Two RJ45 jacks.

The Micrologic trip unit connects to the internal communication terminal block on the Masterpact circuit breaker with the circuit breaker ULP cord. Connection to one of the RJ45 connectors on the FDM121 automatically establishes communication between the Micrologic trip unit and the FDM121 and supplies power to the Micrologic trip unit measurement functions.

When the second connector is not used, it must be fitted with a line terminator.

### Navigation

Five buttons are used for intuitive and fast navigation.

The “Context” button may be used to select the type of display (digital, bargraph, analogue).

The user can select the display language (Chinese, English, French, German, Italian, Portuguese, Spanish, etc.).

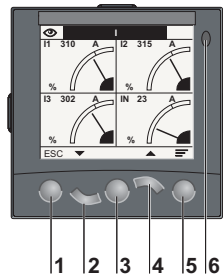

- 1 Escape
- 2 Down
- 3 OK
- 4 Up
- 5 Context
- 6 Alarm LED



Product Identification

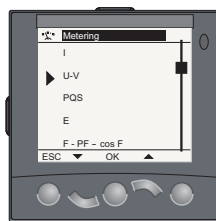

Metering: Submenu

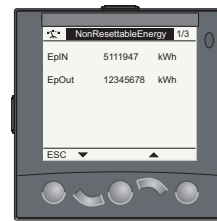

Metering: Meter

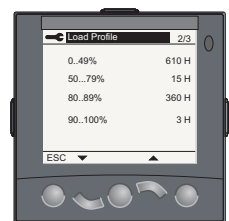

Services

### Screens

#### Main Menu

When powered up, the FDM121 screen automatically displays the ON/OFF status of the device.



Quick View



Metering



Control



Alarms



Services

When not in use, the screen is not backlit. Backlighting can be activated by pressing one of the buttons. It goes off after three minutes.

# Masterpact™ NT and NW Universal Power Circuit Breakers Energy Management

## Fast Access to Essential Information

- “Quick view” provides access to five screens that display a summary of essential operating information (I, U-V, f, P, E, THD, circuit breaker ON/OFF).

## Access to Detailed Information

- “Metering” can be used to display the measurement data (I, U-V, f, P, Q, S, E, THD, PF) with the corresponding min/max values.
- “Alarms” displays active alarms and the alarm history.
- “Services” provides access to the operation counters, energy and maximum ammeter reset function, maintenance indicators, identification of modules connected to the internal bus, and FDM121 internal settings (language, contrast, etc.).

## Communication Components and FDM121 Connections

The FDM121 degree of protection is IP54 in front. IP54 is maintained after switchboard mounting by using the supplied gasket during installation.

**Figure 6: FDM121 Connections**

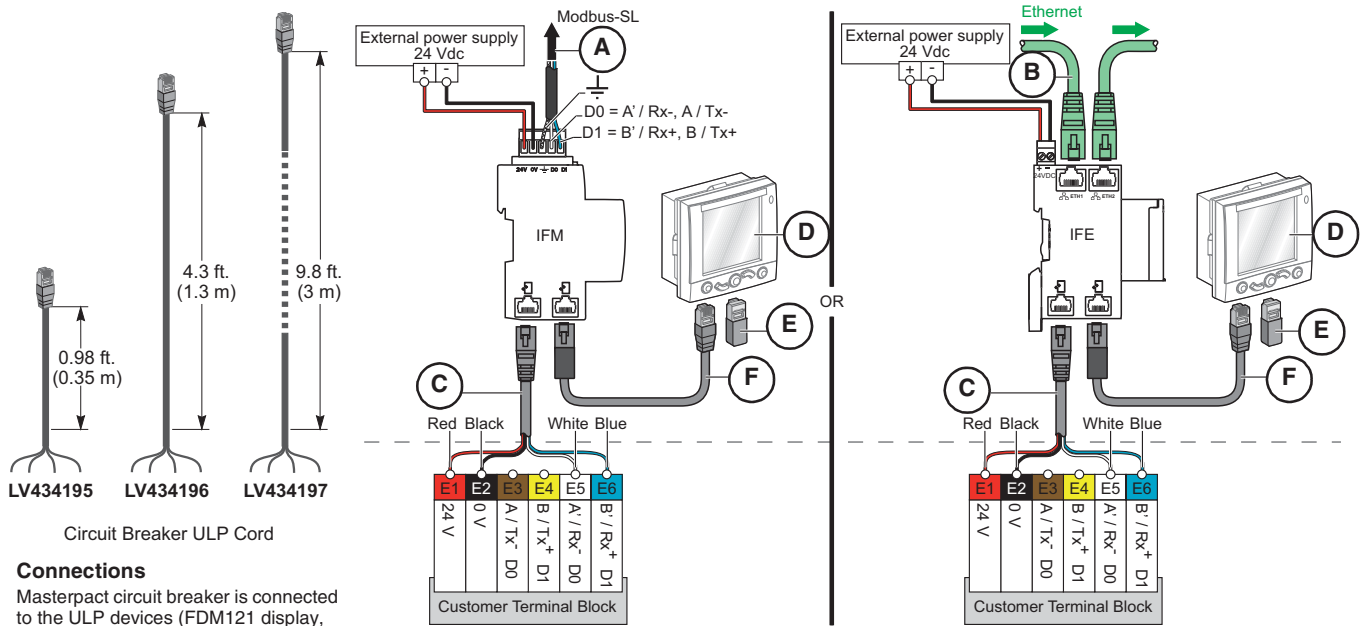

Circuit Breaker ULP Cord

### Connections

Masterpact circuit breaker is connected to the ULP devices (FDM121 display, IFM, IFE or IO unit) via the circuit breaker ULP cord.

- Cord is available in three lengths: 0.98 ft. (0.35 m), 4.3 ft. (1.3 m) and 9.8 ft. (3 m).
- Lengths up to 32.9 ft. (10 m) are possible using extensions.

- A. Modbus Network
- B. Ethernet Network
- C. Circuit Breaker ULP Cord
- D. FDM Display
- E. ULP Termination
- F. ULP Cable

### FDM128 Display

The Micrologic trip unit measurement capabilities are fully utilized with the FDM128 display. The FDM128 display connects to Ethernet communication using the RJ45 port and displays Micrologic trip unit information. The result is an integrated unit combining a circuit breaker with a power meter. Additional operating assistance functions can also be displayed.

The FDM128 display unit can be connected to a Micrologic COM option (BCM ULP through an IFE). It uses the sensors and processing capacity of the Micrologic trip unit and requires no special software or settings. The FDM128 is a large display, but requires very little depth. The anti-glare graphic screen is backlit for easy reading even under poor ambient lighting and at sharp angles.

The FDM128 display is designed to manage up to eight devices (PowerPact H/J/L/P/R or Masterpact NW/NT circuit breakers).

### Display of Micrologic Trip Unit Measurements and Trips

The FDM128 is intended to display Micrologic A/P/H trip unit measurements, trips, and operating information. It cannot be used to modify the protection settings.

- Measurements may be easily accessed using a menu.
- Trips are automatically displayed.
- A pop-up window displays the time-stamped description of the trip.

### Status Indications

When the circuit breaker is equipped with the COM option (BCM ULP) (including its set of sensors) the FDM128 display can also be used to view circuit breaker status conditions:

- O/F: ON/OFF
- SDE: Fault-trip indication (overload, short-circuit, ground fault)
- PF: ready to close
- CH: charged (spring loaded)
- CE, CD, CT cradle management with I/O application module

### Remote Control

When the circuit breaker is equipped with the COM option (BCM ULP) (including connection to shunt close [XF] and shunt trip [MX1] communication voltage releases), the FDM128 display can also be used to operate (open/close) the circuit breaker.

Two operating mode are available:

- Local mode: open/close commands are enabled from the FDM128 while disabled from the communication network.
- Remote mode: open/close commands are disabled from the FDM128 while enabled from the communication network.

# Masterpact™ NT and NW Universal Power Circuit Breakers Energy Management

## Main Characteristics

- 4.54 x 3.40 in. (115.2 x 86.4 mm) with 5.7 in. (145 mm) QVGA display 320 x 240 pixels.
- Color TFT LCD, with LED backlight.
- Wide viewing angle: vertical  $\pm 80^\circ$ , horizontal  $\pm 70^\circ$ .
- High resolution: excellent reading of graphic symbols.
- Operating temperature range: +14 °F (-10 °C) to +131 °F (+55 °C).
- CE / UL / CSA marking.
- 24 Vdc power supply, -10%/+20% (limit 20.4 - 28.8 Vdc).
- Consumption 6.8 W.



FDM128 Display



Surface Mount Accessory



Connection with Display Unit

## Mounting

The FDM128 is easily installed in a switchboard.

- Standard door hole  $\varnothing$  0.87 in. (22 mm).
- The FDM128 degree of protection is IP65 at the touch screen cover. IP54 is maintained after installation by using the supplied gasket.

## Connection

The FDM128 is equipped with:

- a 24 Vdc terminal block:
  - power supply range of 24 Vdc (limit 20.4 - 28.8 Vdc).
  - The FDM128 display unit has a 2-point screw connector on the rear panel of the module for this purpose.
- One RJ45 Ethernet jacks.

The Micrologic trip unit connects to the internal communication terminal block on the Masterpact circuit breakers through the circuit breaker ULP cord and Ethernet connection through the IFE.

## Navigation

- A touch screen is used for intuitive and fast navigation.
- The user can select the display language (Chinese, English, French, German, Italian, Portuguese, Spanish, etc.).

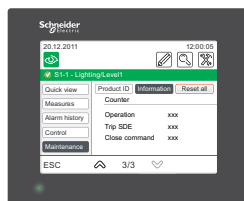

Product Identification

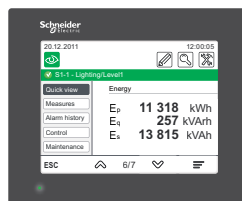

Metering: Meter

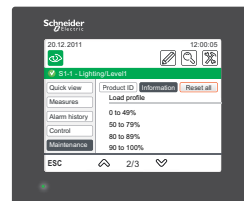

Services

## Screens

### Main Menu



Quick View



Metering



Control



Alarms



Services

When not in use, the screen is automatically shifted to low back-lighting.

# Masterpact™ NT and NW Universal Power Circuit Breakers

## Energy Management

### Fast Access to Essential Information

- “Quick view” provides access to five screens that display a summary of essential operating information (I, U-V, f, P, E, THD, circuit breaker On / Off).

### Access to Detailed Information

- “Metering” can be used to display the measurement data (I, U-V, f, P, Q, S, E, THD, PF) with the corresponding min/max values.
- “Alarms” displays the trip history.
- “Services” provides access to the operation counters, energy and maximum ammeter reset function, maintenance indicators, identification of modules connected to the internal bus and FDM128 internal settings (language, contrast, etc.).

## Communication Components and FDM128 Connections

The FDM128 degree of protection is IP65 at the touch screen cover. IP54 is maintained after installation by using the supplied gasket.

**Figure 7: FDM128 Connections**

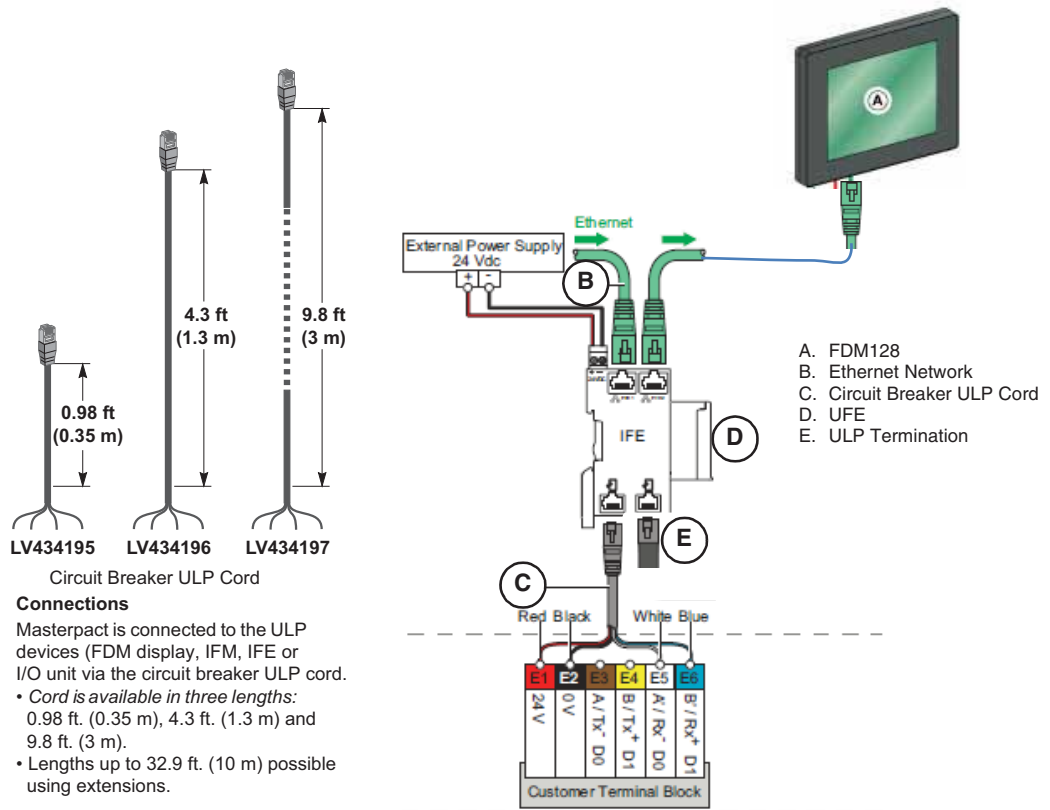

### Connections

Masterpact is connected to the ULP devices (FDM display, IFM, IFE or I/O unit) via the circuit breaker ULP cord.

- Cord is available in three lengths: 0.98 ft. (0.35 m), 4.3 ft. (1.3 m) and 9.8 ft. (3 m).
- Lengths up to 32.9 ft. (10 m) possible using extensions.

# Masterpact™ NT and NW Universal Power Circuit Breakers Energy Management

Figure 8: Panelboard and Switchboard Connections

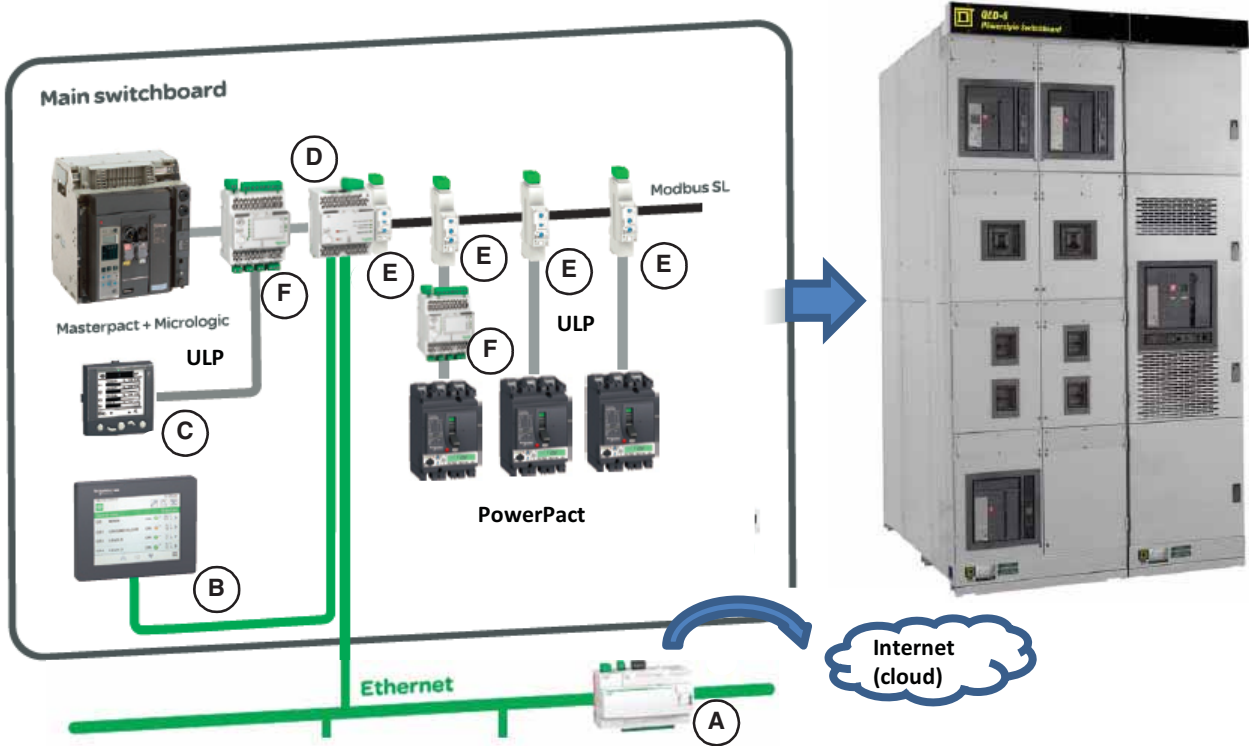







Table 22: Enerlin'X Communication Devices and Displays

	Name	Function	Port		Bin. Input	Analog. Input	Bin. Output
			To Device	To Server			
A	 Com'X 200	Energy Server with Ethernet Gateway® Function	Modbus Master	Ethernet Cable + WiFi	6	2	—
B	 FDM128	Ethernet LCD Color Touch Screen	—	Ethernet	—	—	—
C	 FDM121	LCD Display for Circuit Breaker	ULP	—	—	—	—

*Continued on next page*

# Masterpact™ NT and NW Universal Power Circuit Breakers Energy Management

Table 22: Enerlin'X Communication Devices and Displays (continued)

		Name	Function	Port		Bin. Input	Analog. Input	Bin. Output
				To Device	To Server			
D		IFE Interface + Gateway	Ethernet Interface & Gateway	Modbus Master & ULP	Ethernet	—	—	—
		IFE Interface	Ethernet Interface for Circuit Breakers	ULP	Ethernet	—	—	—
E		IFM	Modbus Interface for Circuit Breakers	ULP	Modbus Slave	—	—	—
F		I/O	Input/Output Application Module for Circuit Breakers	ULP	ULP	6	1	1



## Section 3—Micrologic™ Electronic Trip Systems

Overview of Micrologic Trip Systems .....	38
Thermal Imaging .....	38
True RMS Current Sensing .....	40
Power Supply Information .....	39
Ammeter (A) Trip Unit with 24 Vdc Power Supply at F1 and F2 .....	39
Power (P) and Harmonic (H) Trip Unit without 24 Vdc Power Supply at F1 and F2 .....	39
Power (P) and Harmonic (H) Trip Unit with 24 Vdc Power Supply at F1 and F2 .....	39
Micrologic Trip Units—Overview .....	40
Micrologic 2.0, 3.0, and 5.0 Basic Trip Units .....	42
Protection Settings .....	42
Micrologic 2.0A, 3.0A, 5.0A, & 6.0A Trip Units with Ammeter .....	43
Protection Settings .....	42
Ammeter Measurements .....	43
Communication Network .....	43
Micrologic 5.0P & 6.0P Trip Units with Power Metering.....	45
Configuring Alarms and Other Protection Functions .....	45
Maintenance Record .....	45
Load Shedding and Reconnection Parameters .....	46
Indication Option via Programmable Contacts .....	46
Trip and Alarm Histories .....	47
Metering .....	49
Communication Network .....	43
Event Log .....	48
Micrologic 5.0H and 6.0H Trip Units with Harmonic Metering .....	49
Metering .....	49
Waveform Capture .....	49
Customized Alarm Programming .....	50
Event Logs .....	50
Additional Technical Characteristics for Type P and Type H Trip Units .....	50
Micrologic Trip Unit Functions .....	51
Long-Time Trip Functions .....	51
Short-Time Trip Functions .....	51
Instantaneous Trip Function .....	51
Ground-Fault Trip Functions .....	51
Communication Network .....	43
Wiring System ULP .....	52
Four Functional Levels.....	53
Modbus Principle .....	53
Ethernet Principle.....	54
COM Option in Masterpact Circuit Breakers .....	54
IFE Ethernet Interface .....	56
IFM Modbus Communication Interface .....	59
I/O Application Module .....	62
Electrical Asset Manager Configuration Engineering Tool (Ecoreach™) .....	67
Enerlin'X Communication Wiring System .....	46
COM Option in Masterpact Circuit Breakers .....	48
IFE Ethernet Interface .....	50
IFM Modbus Communication Interface .....	53
I/O Application Module .....	56
Electrical Asset Manager Configuration Engineering Tool (Ecoreach) .....	61

# Masterpact™ NT and NW Universal Power Circuit Breakers

## Micrologic™ Electronic Trip Systems

### Overview of Micrologic Trip Systems

Model	LS0	LI	LSI	LSIG
	Long-Time + Short-Time + Zero Delay	Long-Time + Instantaneous Protection	Long-Time + Short-Time + Instantaneous Protection	Long-Time + Short-Time + Instantaneous Protection + Equipment Ground-Fault Protection
	(IEC Rated)	(UL Listed and ANSI Certified)	(UL Listed, ANSI Certified, IEC Rated)	(UL Listed, ANSI Certified, IEC Rated)
Basic Trip Unit	2.0	3.0	5.0	—
A Trip Unit	2.0A	3.0A	5.0A	6.0A
P Trip Unit	—	—	5.0P	6.0P
H Trip Unit	—	—	5.0H	6.0H

All Masterpact circuit breakers are equipped with the Micrologic trip system to protect power circuits and loads. Micrologic trip systems use a set of current transformers (called CTs or sensors) to sense current, a trip unit to evaluate the current, and a tripping solenoid to trip the circuit breaker. Adjustable rotary switches on the trip unit allow the user to set the proper overcurrent or equipment ground-fault current protection required in the electrical system. If current exceeds a set value for longer than its set time delay, the trip system opens the circuit breaker. Alarms may be programmed for remote indications. Measurements of current, voltage, frequency, power, and power quality optimize continuity of service and energy management. Micrologic trip units can be changed on-site.

Integration of protection functions in the Application Specific Integrated Circuit (ASIC) electronic component used in all Micrologic trip units guarantees a high degree of reliability and immunity to conducted or radiated disturbances. On Micrologic P and H trip units, advanced functions are managed by an independent microprocessor.

Masterpact circuit breakers are shipped with the long-time pickup switch set at 1.0 and all other trip unit adjustments set at their lowest settings. Actual settings required for a specific application must be determined by a qualified consultant or plant engineer. A coordination study is recommended to provide coordination between all circuit breakers in the distribution system.

**Figure 9: P Trip Unit with Power Metering**



### Thermal Imaging

The thermal imaging function protects the cables or bus bars from overheating in case of low amplitude repetitive faults. Such overheating can be due to repetitive motor starting, fluctuating load, intermittent ground faults, or subsequent closing after a fault.

Traditional electronic protection does not protect against repetitive faults because the duration of each overload above the pickup setting is too short to achieve effective tripping. Nevertheless, each overload involves a temperature rise in the installation, the cumulative effect of which could lead to overheating of the system.

The thermal imaging function remembers and integrates the thermal heating caused by each pickup setting overrun. Before tripping, the integrated heating value will reduce the associated time delay and, therefore, the reaction of the trip unit will be closer to the real heating of the power network system. After tripping, the function will also reduce the time delay when closing the circuit breaker on an overload.

# Masterpact™ NT and NW Universal Power Circuit Breakers Micrologic™ Electronic Trip Systems

## Power Supply Information

### Ammeter (A) Trip Unit Without 24 Vdc Power Supply at F1 and F2

Sensor Plug Value (In)	Minimum Ground-Fault Pickup
100–250 A	30% of sensor rating
400–1200 A	20% of sensor rating
1600–6300 A	500 A

- Provides fault protection for LSIG functions.
- Provides LED trip indication (powered by an onboard battery).
- All display functions and trip unit features power-up with current flow on one phase greater than or equal to the values in the table to the left.
- Ground-fault push-to-trip button works for testing ground fault with current flow on one phase greater than or equal to the values shown in the following table.

### Ammeter (A) Trip Unit With 24 Vdc Power Supply at F1 and F2

The Ammeter (A) trip unit provides all of the above plus additional functionality when powered by external 24 Vdc power supply:

- Ammeter and bar graph displays are functional with or without current flowing through the circuit breaker.
- Trip settings and (Max) current readings can be accessed on the display by pressing navigation button with or without current flowing through the circuit breaker.
- The ground-fault push-to-trip button works for testing ground fault with or without current flowing through the circuit breaker.
- Optional Modbus™ communications—also requires a separate 24 Vdc power supply for the circuit breaker communications module.

**NOTE:** Ground-fault push-to-trip button will also be functional if a hand-held test kit or full-function test kit is powering the trip unit.

### Power (P) and Harmonic (H) Trip Unit Without 24 Vdc Power Supply at F1 and F2

The P and H trip units were designed to be used with the external 24 Vdc power supply. The large LCD display requires too much current to be powered by current flow through the circuit breaker. The P and H trip units do have a voltage power supply which will power the trip unit with 100 Vac or more between two phases or phase to neutral. The standard configuration for the voltage probes inside the circuit breaker is at the bottom connections. If the circuit breaker was open in a top fed application, there would be no voltage at the bottom of the circuit breaker and the trip unit would not be powered.

- Provides fault protection for LSIG functions.
- Provides LED trip indication (powered by an onboard battery).

**NOTE:** Ground-fault push-to-trip button works for testing ground fault if the trip unit is powered by the voltage power supply. The ground-fault push-to-trip is also functional if a hand-held test kit or full-function test kit is powering the trip unit.

### Power (P) and Harmonic (H) Trip Unit With 24 Vdc Power Supply at F1 and F2

- Provides all of the above.
- LCD display and backlight are functional.
- Ground-fault push-to-trip button works for testing ground fault.
- All metering, monitoring, and history logs are functional.
- Communications from trip unit to M2C and M6C programmable contact modules are powered by a 24 Vdc supply at F1 and F2. M6C also requires a 24 Vdc external power supply.
- Modbus communications—also requires a separate 24 Vdc power supply for the circuit breaker communications module.

**NOTE:** Ground-fault push-to-trip button will also be functional if hand-held test kit or full-function test kit is powering the trip unit.

# Masterpact™ NT and NW Universal Power Circuit Breakers Micrologic™ Electronic Trip Systems

## Micrologic Trip Units—Overview

### True RMS Current Sensing

The sensing system responds to the flow of current through the circuit breaker. Electronic trip circuit breakers are limited to ac systems because the electronic trip system uses current transformers to sense the current. The Micrologic trip unit samples the current waveform to provide true RMS protection through the 15th harmonic.

This true RMS sensing gives accurate values for the magnitude of a non-sinusoidal waveform. Therefore, the heating effects of harmonically distorted waveforms are accurately evaluated.

The Micrologic H trip unit provides additional sampling of the waveforms to measure and provide waveform capture of harmonic distortion to the 31st harmonic.

Masterpact universal power circuit breakers use Micrologic electronic trip systems to sense overcurrents and trip the circuit breaker. The Micrologic basic trip unit is standard and all Masterpact circuit breakers can be equipped with the optional Micrologic trip systems listed below:

- Micrologic Basic Trip Unit (standard).
  - 2.0 basic protection (LS0, IEC)
  - 3.0 basic protection (LI, UL®/ANSI)
  - 5.0 selective protection (LSI)
- Micrologic A: Trip Unit with Ammeter.
  - 2.0A basic protection (LS0, IEC)
  - 3.0A basic protection (LI, UL/ANSI)
  - 5.0A selective protection (LSI)
  - 6.0A selective protection with ground-fault protection for equipment (LSIG)
- Micrologic P: Trip Unit with Power Metering.
  - 5.0P selective protection (LSI)
  - 6.0P selective protection with ground-fault protection for equipment (LSIG)
- Micrologic H: Trip Unit with Harmonic Metering.
  - 5.0H selective protection (LSI)
  - 6.0H selective protection with ground-fault protection for equipment (LSIG)

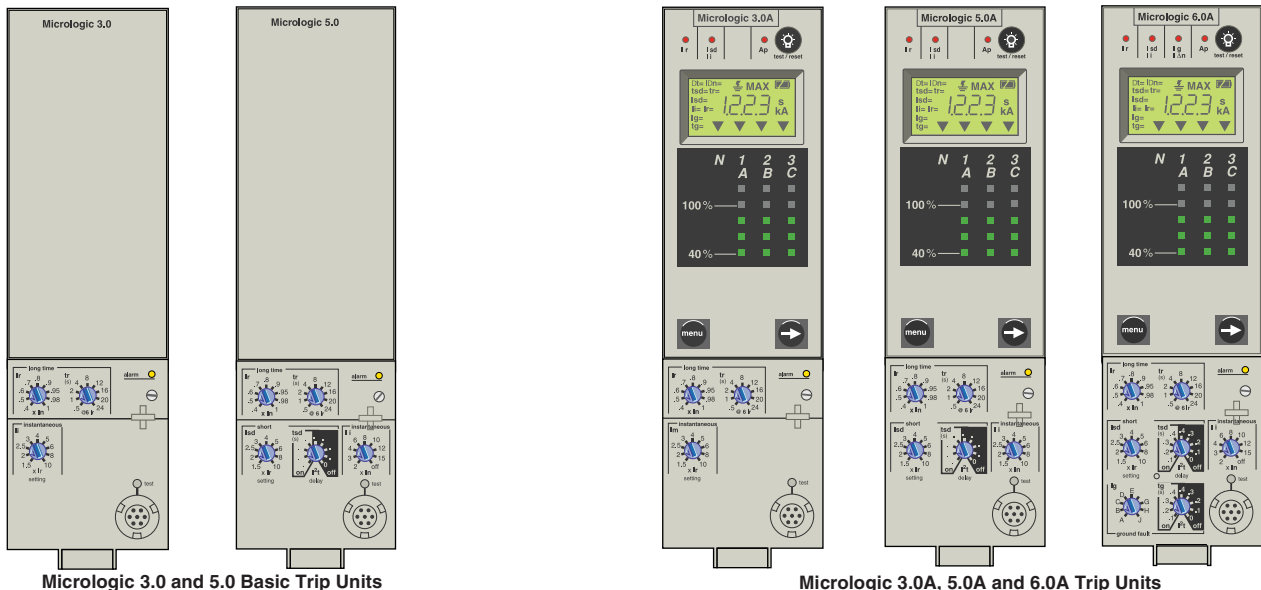

Micrologic 3.0 and 5.0 Basic Trip Units

Micrologic 3.0A, 5.0A and 6.0A Trip Units

# Masterpact™ NT and NW Universal Power Circuit Breakers Micrologic™ Electronic Trip Systems

**Table 23: Micrologic Trip Unit Features**

Feature	Micrologic Trip Unit (X = Standard Feature O = Available Option)										
	Standard			Ammeter				Power		Harmonics	
	2.0	3.0	5.0	2.0A	3.0A	5.0A	6.0A	5.0P	6.0P	5.0H	6.0H
LI		X			X						
LS0	X			X							
LSI			X					X		X	
LSIG/Ground-Fault Trip <sup>1</sup>							X		X		X
Ground-Fault Alarm/No Trip <sup>1,2</sup>								X		X	
Ground-Fault Alarm and Trip <sup>1,2</sup>									X		X
Adjustable Rating Plugs	X	X	X	X	X	X	X	X	X	X	X
True RMS Sensing	X	X	X	X	X	X	X	X	X	X	X
UL Listed		X	X		X	X	X	X	X	X	X
Thermal Imaging	X	X	X	X	X	X	X	X	X	X	X
Phase-Loading Bar Graph				X	X	X	X	X	X	X	X
LED for Long-Time Pick-Up	X	X	X	X	X	X	X	X	X	X	X
LED for Trip Indication				X	X	X	X	X	X	X	X
Digital Ammeter				X	X	X	X	X	X	X	X
Zone-Selective Interlocking <sup>3</sup>				X		X	X	X	X	X	X
Communications				O	O	O	O	X	X	X	X
LCD Dot Matrix Display								X	X	X	X
Advanced User Interface								X	X	X	X
Protective Relay Functions								X	X	X	X
Neutral Protection <sup>1</sup>								X	X	X	X
Contact Wear Indication								X	X	X	X
Incremental Fine Tuning of Settings								X	X	X	X
Selectable Long-Time Delay Bands								X	X	X	X
Power Measurement								X	X	X	X
Power Quality Measurements										X	X
Waveform Capture										X	X

<sup>1</sup> Requires neutral current transformer on three-phase four-wire loads.

<sup>2</sup> Requires the M2C/M6C Programmable Contact Module.

<sup>3</sup> Not available for 2.0A trip unit as upstream devices.

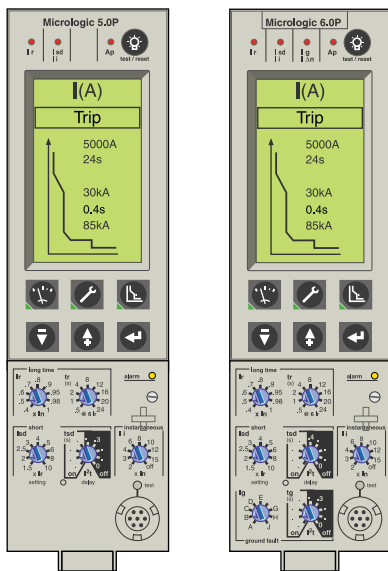

**Micrologic 5.0P and 6.0P Trip Units**

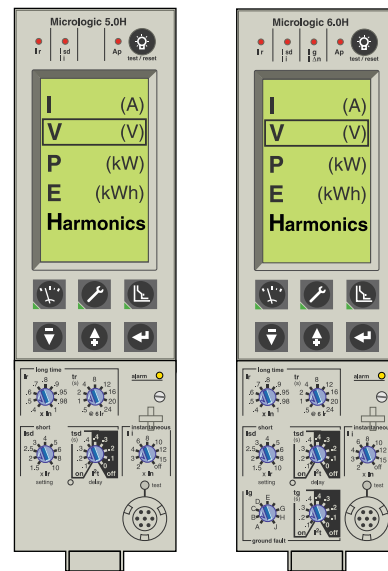

**Micrologic 5.0H and 6.0H Trip Units**

# Masterpact™ NT and NW Universal Power Circuit Breakers Micrologic™ Electronic Trip Systems

## Micrologic 2.0, 3.0, and 5.0 Basic Trip Units

The Micrologic 2.0, 3.0, and 5.0 trip units protect power circuits.

### Protection Settings

- 1—Overload signal (LED)
- 2—Long-time rating plug screw
- 3—Long-time current setting and tripping delay
- 4—Instantaneous pickup
- 5—Short-time pickup and tripping delay
- 6—Test connector

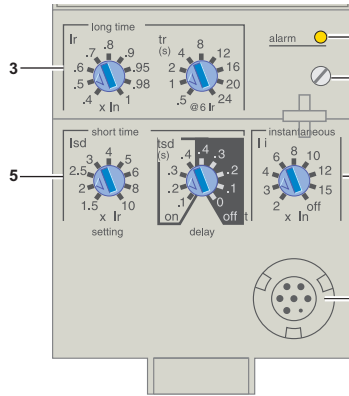

Micrologic 5.0 Basic Trip Unit

Protection thresholds and delays are set using the rotary switches. A full-range of long-time settings are available via the field-installable adjustable rating plugs.

- Overload protection
  - True RMS long-time protection
  - Thermal imaging: active thermal imaging before and after tripping
- Short-circuit protection
  - Short-time RMS
  - Selection of I<sup>2</sup>t type (ON or OFF) for short-time delay
- Instantaneous protection
- Neutral protection on four-pole circuit breakers

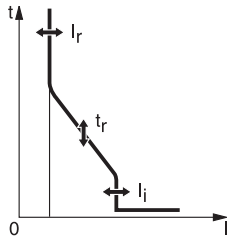

Table 24: Micrologic 2.0 and 3.0 Basic Trip Unit Settings

Protection Type	Setting	Accuracy	Current Setting (A)									
			2.0:	0.40	0.50	0.60	0.70	0.80	0.90	0.95	0.98	1.00
Long-Time Protection	Current Setting (A)		2.0: 0.40 0.50 0.60 0.70 0.80 0.90 0.95 0.98 1.00									
	Tripping Between 1.05 and 1.20 x I <sub>r</sub>	I <sub>r</sub> = I <sub>n</sub> x...	3.0: 0.40 0.45 0.50 0.60 0.63 0.70 0.80 0.90 1.00									
			<i>Other ranges are available by changing rating plug</i>									
	Time Delay (s)	t <sub>r</sub> at 1.5 x I <sub>r</sub>	12.5	25	50	100	200	300	400	500	600	
		t <sub>r</sub> at 6 x I <sub>r</sub>	0.5	1	2	4	8	12	16	20	24	
	Accuracy: 0 to -20%	t <sub>r</sub> at 7.2 x I <sub>r</sub>	0.34	0.69	1.38	2.7	5.5	8.3	11	13.8	16.6	
	Thermal Imaging		20 minutes before or after tripping									
Short-Time Protection	Current Setting (A)											
	Accuracy: ±10%	I <sub>sd</sub> = I <sub>r</sub> x...	2.0:	1.5	2	2.5	3	4	5	6	8	10
Instantaneous Protection	Current Setting (A)											
	Accuracy: ±10%	I <sub>i</sub> = I <sub>n</sub> x...	3.0:	1.5	2	3	4	5	6	8	10	12

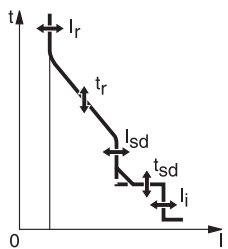

Table 25: Micrologic 5.0 Basic Trip Unit Settings

Protection Type	Setting	Accuracy	Current Setting (A)										
			IEC:	0.40	0.50	0.60	0.70	0.80	0.90	0.95	0.98	1.00	
Long-Time Protection	Current Setting (A)		IEC: 0.40 0.50 0.60 0.70 0.80 0.90 0.95 0.98 1.00										
	Tripping Between 1.05 and 1.20 x I <sub>r</sub>	I <sub>r</sub> = I <sub>n</sub> x...	UL/ANSI: 0.40 0.45 0.50 0.60 0.63 0.70 0.80 0.90 1.00										
			<i>Other ranges are available by changing rating plug</i>										
	Time Delay (s)	t <sub>r</sub> at 1.5 x I <sub>r</sub>	12.5	25	50	100	200	300	400	500	600		
		t <sub>r</sub> at 6 x I <sub>r</sub>	0.5	1	2	4	8	12	16	20	24		
	Accuracy: 0 to -20%	t <sub>r</sub> at 7.2 x I <sub>r</sub>	0.34	0.69	1.38	2.7	5.5	8.3	11	13.8	16.6		
	Thermal Imaging		20 minutes before or after tripping										
Short-Time Protection	Current Setting (A)												
	Accuracy: ±10%	I <sub>sd</sub> = I <sub>r</sub> x...	1.5	2	2.5	3	4	5	6	8	10		
		Settings	I <sup>2</sup> t OFF	0	0.1	0.2	0.3	0.4					
			I <sup>2</sup> t ON	0.1	0.2	0.3	0.4						
	Time Delay (s) at 10 x I <sub>r</sub>	t <sub>sd</sub>	Min. trip time (ms)	20	80	140	230	350					
		Max. trip time (ms)	80	140	200	320	500						
Instantaneous Protection	Current Setting (A)												
	Accuracy: ±10%	I <sub>i</sub> = I <sub>n</sub> x...	2	3	4	6	8	10	12	15	off		

# Masterpact™ NT and NW Universal Power Circuit Breakers Micrologic™ Electronic Trip Systems

## Micrologic 2.0A, 3.0A, 5.0A, & 6.0A Trip Units with Ammeter

Micrologic A trip units protect power circuits and provide current measurements, overload protection, and short-circuit protection. In addition, the 6.0A trip units also provide ground-fault protection for equipment.

### Protection Settings

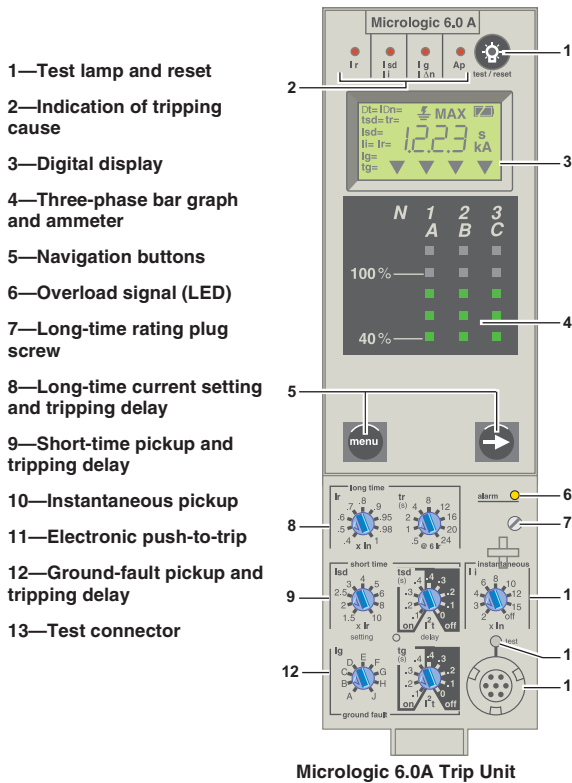

Micrologic 6.0A Trip Unit

Protection thresholds and delays are set using the rotary switches. The selected values are momentarily displayed in amperes and in seconds. A full-range of long-time settings are available via the field-installable rating plug.

- Overload protection (true RMS long-time protection)
- Thermal imaging (active thermal imaging before and after tripping)
- Short-circuit protection
  - Short-time RMS
  - I<sup>2</sup>t ON or OFF for short-time delay
- Instantaneous protection
- Ground-fault protection for equipment
  - Residual ground-fault protection for equipment
  - Source ground-return ground-fault protection for equipment
  - Modified differential ground-fault protection (MDGF) for equipment
- Neutral protection on four-pole circuit breakers
- ZSI: Zone-selective interlocking
  - A ZSI terminal block may be used to interconnect a number of trip units to provide total discrimination for short-time and equipment ground-fault protection, without delay for tripping
  - Not available for 3.0 A trip unit
  - Not available for 2.0 A trip unit if installed as upstream device

### Ammeter Measurements

Micrologic A trip units measure the true RMS value of currents. They provide continuous current measurement from 0.2 to 20 x I<sub>n</sub> with an accuracy of 1.5% (including sensors). No auxiliary source is needed where I > 0.2 x I<sub>n</sub>. The optional external power supply (24 Vdc) makes it possible to display currents where I < 0.2 x I<sub>n</sub> and to store values of the interrupted current. A digital LCD screen continuously displays the most heavily loaded phase (I<sub>max</sub>) or displays the I<sub>a</sub>, I<sub>b</sub>, I<sub>c</sub>, I<sub>g</sub>, and (on four-pole circuit breakers only) I<sub>n</sub> stored current and setting values by successively pressing the navigation button.

### Communication Network

Four wire Modbus, RTU, RS485 or two wire Modbus, TRU, RS485 plus ULP. See page 101.

In conjunction with an optional communication network, the trip unit transmits the following parameters:

- Setting values.
- All ammeter measurements.
- Tripping causes.

**NOTE:** Current-based protection functions require no auxiliary power source. When an external power supply is added, the value of the interrupted current is stored by the trip unit. The reset button resets alarms and stored interrupted current indications.



# Masterpact™ NT and NW Universal Power Circuit Breakers

## Micrologic™ Electronic Trip Systems

**Table 26: Micrologic 2.0A and 3.0A Trip Unit Settings**

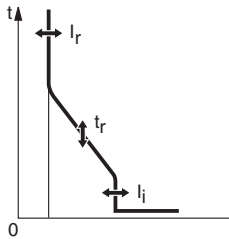

Long-Time Protection	Current Setting (A) Tripping Between 1.05 and 1.20 x I <sub>r</sub>	I <sub>r</sub> = I <sub>n</sub> x...	2.0A: 0.40 0.50 0.60 0.70 0.80 0.90 0.95 0.98 1.00	3.0A: 0.40 0.45 0.50 0.60 0.63 0.70 0.80 0.90 1.00	
	<i>Other ranges are available by changing rating plug</i>				
	Time Delay (s) Accuracy: 0 to -20%	t <sub>r</sub> at 1.5 x I <sub>r</sub>		12.5 25 50 100 200 300 400 500 600	
		t <sub>r</sub> at 6 x I <sub>r</sub>		0.5 1 2 4 8 12 16 20 24	
	t <sub>r</sub> at 7.2 x I <sub>r</sub>		0.34 0.69 1.38 2.7 5.5 8.3 11 13.8 16.6		
	Thermal Imaging		20 minutes before or after tripping		
Short-Time Protection	Current Setting (A) Accuracy: ±10% No delay	I <sub>sd</sub> = I <sub>r</sub> x...	2.0A: 1.5 2 2.5 3 4 5 6 8 10		
Instantaneous Protection	Current Setting (A) Accuracy: ±10%	I <sub>i</sub> = I <sub>n</sub> x...	3.0A: 1.5 2 3 4 5 6 8 10 12		

**Table 27: Micrologic 5.0A and 6.0A Trip Unit Settings**

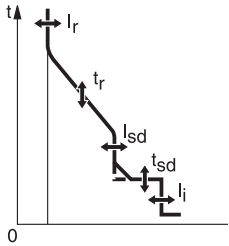

Long-Time Protection	Current Setting (A) Tripping Between 1.05 and 1.20 x I <sub>r</sub>	I <sub>r</sub> = I <sub>n</sub> x...	IEC: 0.40 0.50 0.60 0.70 0.80 0.90 0.95 0.98 1.00	UL/ANSI: 0.40 0.45 0.50 0.60 0.63 0.70 0.80 0.90 1.00	
	<i>Other ranges are available by changing rating plug</i>				
	Time Delay (s) Accuracy: 0 to -20%	t <sub>r</sub> at 1.5 x I <sub>r</sub>		12.5 25 50 100 200 300 400 500 600	
		t <sub>r</sub> at 6 x I <sub>r</sub>		0.5 1 2 4 8 12 16 20 24	
	t <sub>r</sub> at 7.2 x I <sub>r</sub>		0.34 0.69 1.38 2.7 5.5 8.3 11 13.8 16.6		
	Thermal Imaging		20 minutes before or after tripping		
Short-Time Protection	Current Setting (A) Accuracy: ±10%	I <sub>sd</sub> = I <sub>r</sub> x...	1.5 2 2.5 3 4 5 6 8 10		
	Settings	I <sup>2</sup> t OFF	0 0.1 0.2 0.3 0.4		
		I <sup>2</sup> t ON	0.1 0.2 0.3 0.4		
	Time Delay (s) at 10 x I <sub>r</sub>	t <sub>sd</sub>	Min. trip time (ms)	20 80 140 230 350	
		Max. trip time (ms)	80 140 200 320 500		
Instantaneous Protection	Current setting (A) Accuracy: ±10%	I <sub>i</sub> = I <sub>n</sub> x...	2 3 4 6 8 10 12 15 off		

**Table 28: Micrologic 6.0A Trip Unit Ground-Fault Settings**

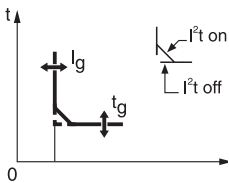

Ground-Fault Pickup (A) Accuracy: ±10%	I <sub>g</sub> = I <sub>n</sub> x...	A B C D E F G H J	
	I <sub>n</sub> ≤ 400 A	0.3 0.3 0.4 0.5 0.6 0.7 0.8 0.9 1.0	
	400 A < I <sub>n</sub> ≤ 1200 A	0.2 0.3 0.4 0.5 0.6 0.7 0.8 0.9 1.0	
	I <sub>n</sub> > 1200 A	500 640 720 800 880 960 1040 1120 1200	
Time Delay (s) at 1 x I <sub>n</sub>	Settings	I <sup>2</sup> t OFF	0 0.1 0.2 0.3 0.4
		I <sup>2</sup> t ON	0.1 0.2 0.3 0.4
	t <sub>g</sub>	Minimum Trip Time (ms)	20 80 140 230 350
		Maximum Trip Time (ms)	80 140 200 320 500



# Masterpact™ NT and NW Universal Power Circuit Breakers Micrologic™ Electronic Trip Systems

## Micrologic 5.0P & 6.0P Trip Units with Power Metering

### Protection Settings

- 1—Test lamp and indication reset
- 2—Indication of tripping cause
- 3—High resolution screen
- 4—Measurement display
- 5—Maintenance indicators
- 6—Protection settings
- 7—Navigation buttons
- 8—Overload signal (LED)
- 9—Long-time rating plug screw
- 10—Long-time current setting and tripping delay
- 11—Short-time pickup and tripping delay
- 12—Instantaneous pickup
- 13—Hole for settings lockout pin
- 14—Electronic push-to-trip
- 15—Ground-fault pickup and tripping delay
- 16—Test connector

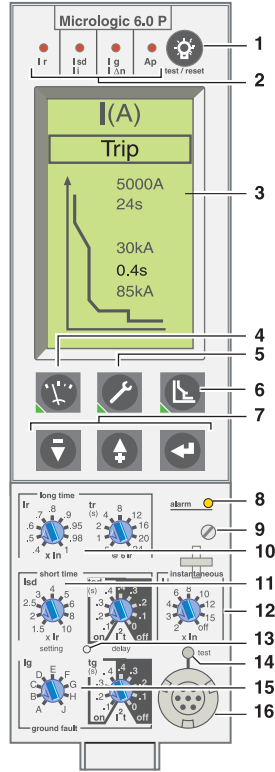

Micrologic 6.0P Trip Unit

The adjustable protection functions of the 5.0P and 6.0P trip units are identical to those of Micrologic A trip unit (overloads, short circuits, equipment ground-fault protection); see page 43.

These units also feature:

- **Fine adjustment:** Within the range below the rotary switch setting, fine adjustments of pickups/delays in steps of 1 A/s (except for short-time and ground-fault) are possible on the keypad or remotely by the communication network.
- **Inverse definite minimum time lag (IDMTL) setting:** Coordination with fuse-type or medium-voltage protection systems is optimized by adjusting the long-time delay curve around  $6 \times I_r$  axis. This setting ensures better coordination with certain loads.
- **Neutral protection:** On three-pole circuit breakers, neutral protection may be set using the keypad or remotely using the communication network to one of four positions:

- OFF
- $1/2N$  ( $1/2 \times I_n$ )
- $1N$  ( $1 \times I_n$ )
- $2N$  ( $2 \times I_n$ )

**NOTE:** The neutral protection is disabled if the long-time curve is set to one of the IDMTL protection settings.

### Configuring Alarms and Other Protection Functions

When the cover is closed, the keypad may no longer be used to change the protection settings, but it still provides access to the displays for measurements, histories, indicators, etc. Depending on the thresholds and time delays set, the Micrologic P trip unit monitors current, voltage, power, frequency, and phase sequence. Each threshold overrun may be signalled remotely via the communication network.

Each threshold overrun may be combined with tripping (protection) or an indication carried out by an optional M2C/M6C programmable contact (alarm), or both (protection and alarm).

### Maintenance Record

The maintenance record can be consulted using the full-function test kit or remotely via the communication network. It can be used as an aid in troubleshooting and to assist scheduling for device maintenance operations.

Recorded indications include:

- Highest current measured
- Operation counter (both cumulative total and total since last reset)
- Number of test kit connections
- Number of trips in operating mode
- Contact wear (Masterpact NW only)

# Masterpact™ NT and NW Universal Power Circuit Breakers

## Micrologic™ Electronic Trip Systems

### Load Shedding and Reconnection Parameters

Load shedding and reconnection parameters can be set according to the power or the current flowing through the circuit breaker. Load shedding is carried out by a remote computer via the communication network or by an M2C or M6C programmable contact.

### Indication Option via Programmable Contacts

The M2C (two contacts) and M6C (six contacts) programmable contacts may be used to signal threshold overruns or status changes. They can be programmed using the keypad on the Micrologic P and H trip units or remotely using the communication network. These contacts are required to obtain data from the protective relay functions on Type P and Type H trip units.

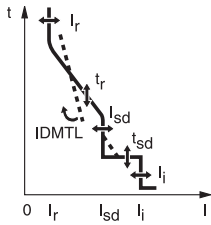

**Table 29: Micrologic 5.0P and 6.0P Trip Unit Settings**

Long-Time (RMS) Protection	Current Setting (A)	$I_r = I_n \times \dots$	IEC:	0.40	0.50	0.60	0.70	0.80	0.90	0.95	0.98	1.00	
	Tripping Between 1.05 and 1.20 x $I_r$	$I_r = I_n \times \dots$	UL/ANSI:	0.40	0.45	0.50	0.60	0.63	0.70	0.80	0.90	1.00	
	Other ranges are available by changing rating plug												
	Time Delay (s)	$t_r$ at 1.5 x $I_r$	12.5	25	50	100	200	300	400	500	600		
	Accuracy: 0 to -20%	$t_r$ at 6 x $I_r$	0.5	1	2	4	8	12	16	20	24		
		$t_r$ at 7.2 x $I_r$	0.34	0.69	1.38	2.7	5.5	8.3	11	13.8	16.6		
	IDMTL Setting	Curve slope	SIT	VIT	EIT	HV Fuse						DT	
	Thermal Imaging		20 minutes before or after tripping										
Short-Time (RMS) Protection	Current Setting (A)	$I_{sd} = I_r \times \dots$	1.5	2	2.5	3	4	5	6	8	10		
	Time Delay (s) at 10 x $I_r$	Settings	$I^2t$ OFF	0	0.1	0.2	0.3	0.4					
			$I^2t$ ON	0.1	0.2	0.3	0.4						
		$t_{sd}$	Min. trip time (ms)	20	80	140	230	350					
	Max. trip time (ms)		80	140	200	320	500						
Instantaneous Protection	Current Setting (A)	$I_i = I_n \times \dots$	2	3	4	6	8	10	12	15	off		

**Table 30: Micrologic 6.0P Trip Unit Ground-Fault Setting**

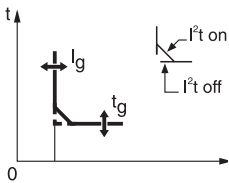

Ground-Fault Pickup (A)	Accuracy: ±10%	$I_g = I_n \times \dots$	A	B	C	D	E	F	G	H	J	
		$I_n \leq 400$ A	0.3	0.3	0.4	0.5	0.6	0.7	0.8	0.9	1.0	
		$400$ A < $I_n \leq 1200$ A	0.2	0.3	0.4	0.5	0.6	0.7	0.8	0.9	1.0	
		$I_n > 1200$ A	500	640	720	800	880	960	1040	1120	1200	
Time Delay (s) at 1 x $I_n$	Settings	$I^2t$ OFF	0	0.1	0.2	0.3	0.4					
		$I^2t$ ON	0.1	0.2	0.3	0.4						
		$t_g$	Minimum trip time (ms)	20	80	140	230	350				
Maximum trip time (ms)	80		140	200	320	500						

**Table 31: Settings for Alarms for Other Protection Functions for Micrologic 5.0P and 6.0P Trip Units**

		Threshold	Time Delay
Current	Current Imbalance	0.05 to 0.6 x $I_{max}$	1 to 40 s
	Maximum Current	$I_{max}$ : $I_a, I_b, I_c, I_n, I_g$	15 to 1500 s
Voltage	Voltage Imbalance	0.02 to 0.3 x $V_n$	1 to 40 s
	Minimum Voltage	$V_{min}$	100 to 725 V (phase total)
Power	Maximum Voltage	$V_{max}$	100 to 1200 V (between phases)
	Maximum Power	$P_{max}$	5 to 500 kW
Frequency	Reverse Power	$P_r$	0.02 to 0.2 x $P_n$
	Minimum Frequency	$F_{min}$	0.2 to 20 s
Phase	Maximum Frequency	$F_{max}$	45 to 65 Hz
	Sequence	$\Delta\emptyset$	45 to 540 Hz
		$\emptyset A-\emptyset B-\emptyset C$ or $\emptyset A-\emptyset C-\emptyset B$	Instantaneous

# Masterpact™ NT and NW Universal Power Circuit Breakers Micrologic™ Electronic Trip Systems

**Table 32: Load-Shedding Settings for Current and Power Metering for Micrologic 5.0P and 6.0P Trip Units**

		Pick-Up		Drop-Out	
		Threshold	Time Delay	Threshold	Time Delay
Current	I	0.5 to 1.0 x I <sub>r</sub> per phase	20% to 80% x t <sub>r</sub>	0.3 to 1.0 x I <sub>r</sub> per phase	10 to 600 s
Power	P	200 kW to 10 MW	10 to 3600 s	100 kW to 10 MW	10 to 3600 s

## Trip and Alarm Histories

The last ten trips and ten alarms are recorded in two separate history files that can be displayed on the screen (sample displays are shown to the right). The following information is contained in these files:

### Trip History

- Type of fault
- Date and time of fault
- Interrupted current
- Contact wear

Trip history
li 05 / 20 / 00
li 04 / 28 / 00
Vmin 04 / 28 / 00

Trip
05 / 20 / 00 10:23:42 am li 7200 A
I <sub>a</sub> = 7800 A I <sub>b</sub> = 7800 A I <sub>c</sub> = 7800 A I <sub>n</sub> = 7800 A

### Alarm History

- Type of alarm
- Date and time of the alarm
- Values measured at the time of the alarm

Alarm history
AI ≠ 05 / 20 / 00
AI ≠ 04 / 28 / 00
AI ≠ 02 / 28 / 00

Trip
05 / 20 / 00 AI ≠ 996A

# Masterpact™ NT and NW Universal Power Circuit Breakers

## Micrologic™ Electronic Trip Systems

### Metering

The Micrologic P trip unit calculates in real time all electrical values V, A, W, VAR, VA, Wh, VARh, VAh, Hz, power factor, and crest factor. The Micrologic P trip unit also calculates demand current and demand power over an adjustable time period.

**Real-Time Metering:** The value displayed on the screen is refreshed every second. Minimum and maximum measurement values are stored in memory.

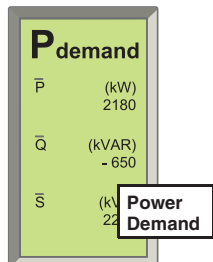
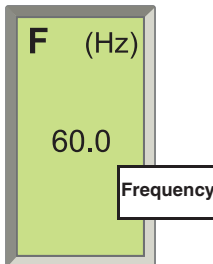
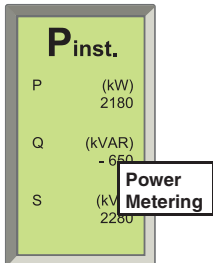
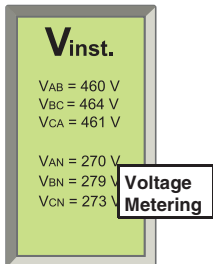
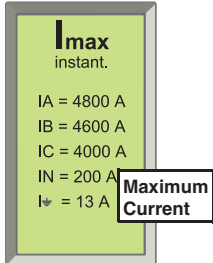
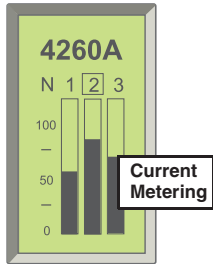

Type of Measurement	Unit of Measurement	Measurement Source
Current	I <sub>RMS</sub>	A ØA, ØB, ØC or N
	I <sub>AVERAGE</sub>	A (ØA + ØB + ØC)/3
	I <sub>PEAK/√2</sub>	A ØA, ØB, ØC or N
Voltage	V <sub>RMS</sub>	V (ØA-ØB), (ØB-ØC) and (ØC-ØA)
	V <sub>RMS</sub>	V (ØA-N), (ØB-N) and (ØC-N)
	V <sub>IMBALANCE</sub>	% V <sub>RMS</sub>
Power	P, Q and S	W, VAR, VA Total
	EP, EQ and ES	Wh, VARh, VAh Total
	Power factor	Total
Frequency	F	Hz 50/60

**Demand Metering:** The demand is calculated over a fixed or sliding time window that can be programmed from five to sixty minutes. Depending on the contract signed with the power supplier, specific programming makes it possible to avoid or minimize the cost of overrunning the subscribed power. Maximum demand values are systematically stored and time stamped.

Type of Measurement	Unit of Measurement	Measurement Source
Current	I <sub>DEMAND</sub>	A ØA, ØB, ØC or N
Power	P, Q and S <sub>DEMAND</sub>	W, VAR, VA Total

### Communication Network

Four wire Modbus, RTU, RS485—The communication network may be used to:

- Remotely read parameters for the protection functions.
- Transmit all the measurements and calculated values.
- Signal the causes of tripping and alarms.
- Consult the history files and the maintenance indicator record.

In addition, an event log of the last 100 events and a maintenance record, which is stored in the trip unit memory but not available locally, may be accessed via the communication network.

The Modbus communication system is compatible with Powerlogic™ System Manager™ (SMS) software.

### Event Log

The event log may be accessed by a remote computer via the communication network. All events are time stamped and include:

- Trips
- Beginning and end of alarms
- Modifications to settings and parameters
- Loss of time
- Overrun of wear indicators
- Test kit connections
- Counter resets
- System faults (thermal self-protection, major fault and minor fault alarms)

# Masterpact™ NT and NW Universal Power Circuit Breakers Micrologic™ Electronic Trip Systems

## Micrologic 5.0H & 6.0H Trip Units with Harmonic Metering



**Micrologic 6.0H Trip Unit**

In addition to the P functions, the Micrologic H trip units offer:

- In-depth analysis of power quality including calculation of harmonics and the fundamentals.
- Diagnostics aid and event analysis through waveform capture.
- Customized alarm programming to analyze and track down a disturbance on the ac power system.
- Systematic time stamping of all events and creation of logs.

### Metering

The Micrologic H trip unit offers all the measurements carried out by the Micrologic P trip unit, with the addition of phase-by-phase measurements of power and energy as well as calculation of:

- Current and voltage total harmonic distortion (THD, thd).
- Current, voltage and power fundamentals (50/60 Hz).
- Harmonic components (amplitude and phase) up to the 31st current and voltage harmonic.

**Real-Time Metering:** The value displayed on the screen is refreshed every second. The table below shows what is measured in real-time metering.

Type of Measurement		Unit of Measurement	Measurement Source
Current	$I_{RMS}$	A	$\emptyset A, \emptyset B, \emptyset C$ or N
	$I_{AVERAGE}$	A	$(\emptyset A + \emptyset B + \emptyset C) / 3$
	$I_{PEAK/\sqrt{2}}$	A	$\emptyset A, \emptyset B, \emptyset C$ or N
	$I_{IMBALANCE}$	%	$\emptyset A, \emptyset B, \emptyset C$ or N
Voltage	$V_{RMS}$	V	$(\emptyset A-\emptyset B), (\emptyset B-\emptyset C)$ and $(\emptyset C-\emptyset A)$
	$V_{RMS}$	V	$(\emptyset A-N), (\emptyset B-N)$ and $(\emptyset C-N)$
	$V_{IMBALANCE}$	%	$V_{RMS}$
Power	P, Q and S	W, VAR, VA	Total
	EP, EQ and ES	Wh, VARh, VAh	Total
	Power factor		Total
Frequency	F	Hz	$\emptyset A, \emptyset B,$ or $\emptyset C$
Power Quality Indicators	Fundamentals	50/60 Hz component	V, I, P, Q, and S
	THD	%	V/I
	V and I harmonics	Amplitude to phase	1, 2, 3, 4...50

**Demand Metering:** Similar to the Micrologic P trip unit, demand values are calculated over a fixed or sliding time window that can be set from five to 60 minutes.

Type of Measurement		Unit of Measurement	Measurement Source
Current	$I_{DEMAND}$	A	$\emptyset A, \emptyset B, \emptyset C$ or N
Power	P, Q and $S_{DEMAND}$	W, VAR, VA	Total

### Waveform Capture

Micrologic H trip units can capture and store current and voltage waveforms using digital sampling techniques similar to those used in oscilloscopes. Using the information available in the captured waveform, it is possible to determine the level of harmonics as well as the direction and amplitude of the flow of harmonic power.

Users of Micrologic H trip units can record manually via the keypad the following waveforms:

- The four currents:  $I_a, I_b, I_c,$  and  $I_N$
- The three phase-to-phase voltages:  $V_{ab}, V_{bc},$  and  $V_{ca}$

# Masterpact™ NT and NW Universal Power Circuit Breakers

## Micrologic™ Electronic Trip Systems

Waveforms may be displayed on the graphic screen of Micrologic H trip units or communicated over a networked system. The recording takes place over one cycle with a measurement range of 0 to 1.5  $I_N$  for current and 0 to 690 volts for voltage. The resolution is sixty-four points per cycle.

### Customized Alarm Programming

The instantaneous value of each measurement can be compared to user-set high and low thresholds. Overrun of a threshold generates an alarm. Programmable action can be linked to each alarm, including circuit breaker opening, activation of an M2C or M6C contact, recording of measurements in a log, etc.

### Event Logs

Each event is recorded with:

- The date, time, and name of the event.
- The event characteristics.

### Additional Technical Characteristics for Type P and Type H Trip Units

- Setting the display language: System messages can be displayed in six different languages:
  - English - US
  - English - UK
  - French
  - German
  - Spanish
  - Italian

The desired language is selected via the keypad.

- Protection functions: All current-based protection functions require no auxiliary source. Voltage-based protection functions are connected to ac power via a voltage measurement input built into the circuit breaker on the bottom side. (Optional external voltage measurement is available.)
- Accuracy of measurements (including sensors):
  - Voltage (V) 1%
  - Current (A) 1.5% (higher accuracy [1%] may be achieved with special calibration on the current transformer [CT characterization option])
  - Frequency (Hz) 0.1 Hz
  - Power (W) and energy (Wh) 2.5%
  - The Micrologic H trip unit uses a dedicated metering data chain separate from the protection data chain so that a greater number of data samples can be used for metering. This increases the number of samples taken per time period, which in turn gives the H trip unit a higher degree of metering accuracy.
- Stored information: The fine setting adjustments, the last 100 events and the maintenance record remain in the trip unit memory even when power is lost.
- Reset: An individual reset, via the keypad or remotely, will reset alarms, minimum and maximum data, peak values, counters and the indicators.

# Masterpact™ NT and NW Universal Power Circuit Breakers Micrologic™ Electronic Trip Systems

## Micrologic Trip Unit Functions

### Long-Time Trip Functions

The *long-time pickup* switch sets the maximum current level the circuit breaker will carry continuously. The maximum current level ( $I_p$ ) is the long-time pickup setting multiplied by the sensor plug amperage ( $I_n$ ). If the current exceeds this value for longer than the long-time delay time, the circuit breaker will trip.

The *long-time delay* switch sets the length of time that the circuit breaker will carry a sustained overload before tripping. Delay bands are labeled in seconds of overcurrent at six times the ampere rating. For maximum coordination, there are eight delay bands. Long-time delay is an “inverse time” characteristic in that the delay time decreases as the current increases.

The trip unit includes an *alarm indicator* that will be lit continuously when the current is above 100% of the pickup setting.

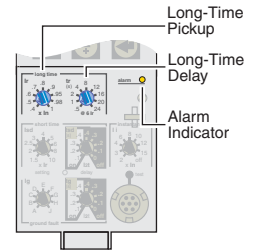

Long-Time Trip Functions

### Short-Time Trip Functions

The *short-time pickup* switch sets the short-circuit current level at which the circuit breaker will trip after the set short-time delay. The short-time current ( $I_{sd}$ ) equals the short-time pickup setting multiplied by the long-time pickup ( $I_p$ ).

The *short-time delay* switch sets the length of time the circuit breaker will carry a short circuit within the short-time pickup range. The delay (based on 10 times the ampere rating  $I_p$ ) can be adjusted to four positions of  $I^2t$  ramp operation ( $I^2t$  ON) or five positions of fixed time delays ( $I^2t$  OFF).  $I^2t$  ON delay is an “inverse time” characteristic in that the delay time decreases as the current increases. Short-time delay for the 2.0 trip unit is fixed at a delay band of 20 to 80 ms.

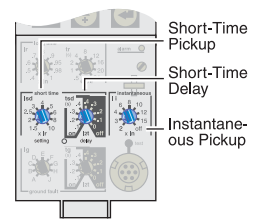

Short-Time and Instantaneous Trip Functions

### Instantaneous Trip Function

The *instantaneous pickup* switch sets the short-circuit current level at which the circuit breaker will trip with no intentional time delay. The instantaneous current ( $I_i$ ) is equal to the instantaneous pickup setting multiplied by the sensor plug amperage ( $I_n$ ).

The instantaneous function will override the short-time function if the instantaneous pickup is adjusted at the same or lower setting than the short-time pickup. In trip units with both adjustable short-time and instantaneous trip functions, the adjustable instantaneous trip can be disabled by setting Instantaneous pickup to OFF.

### Ground-Fault Trip Functions

The *ground-fault pickup* switch sets the current level at which the circuit breaker will trip after the set ground-fault delay. Ground-fault pickup values ( $I_g$ ) are based on circuit breaker sensor plug ( $I_n$ ) only, not on the rating plug multiplier ( $I_r$ ). Changing the rating plug multiplier has no effect on ground-fault pickup values.

The *ground-fault delay* switch sets the length of time the circuit breaker will carry ground-fault current which exceeds the ground-fault pickup level before tripping. The delay (based on the sensor plug amperage ( $I_n$ )) can be adjusted to four positions of  $I^2t$  ramp operation ( $I^2t$  ON) or five positions of fixed time delays ( $I^2t$  OFF).  $I^2t$  ON delay is an “inverse time” characteristic in that the delay time decreases as the current increases.

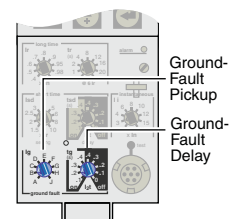

Ground-Fault Trip Functions



**Masterpact™ NT and NW Universal Power Circuit Breakers  
Micrologic™ Electronic Trip Systems**

**Enerlin'X Communication Wiring System**

**Wiring System ULP**

The wiring system is designed for low-voltage power switchboards. Installation does not require special tools or training. The prefabricated wiring ensures both data transmission (Modbus protocol) and 24 Vdc power distribution for the communications modules on the Micrologic trip units.

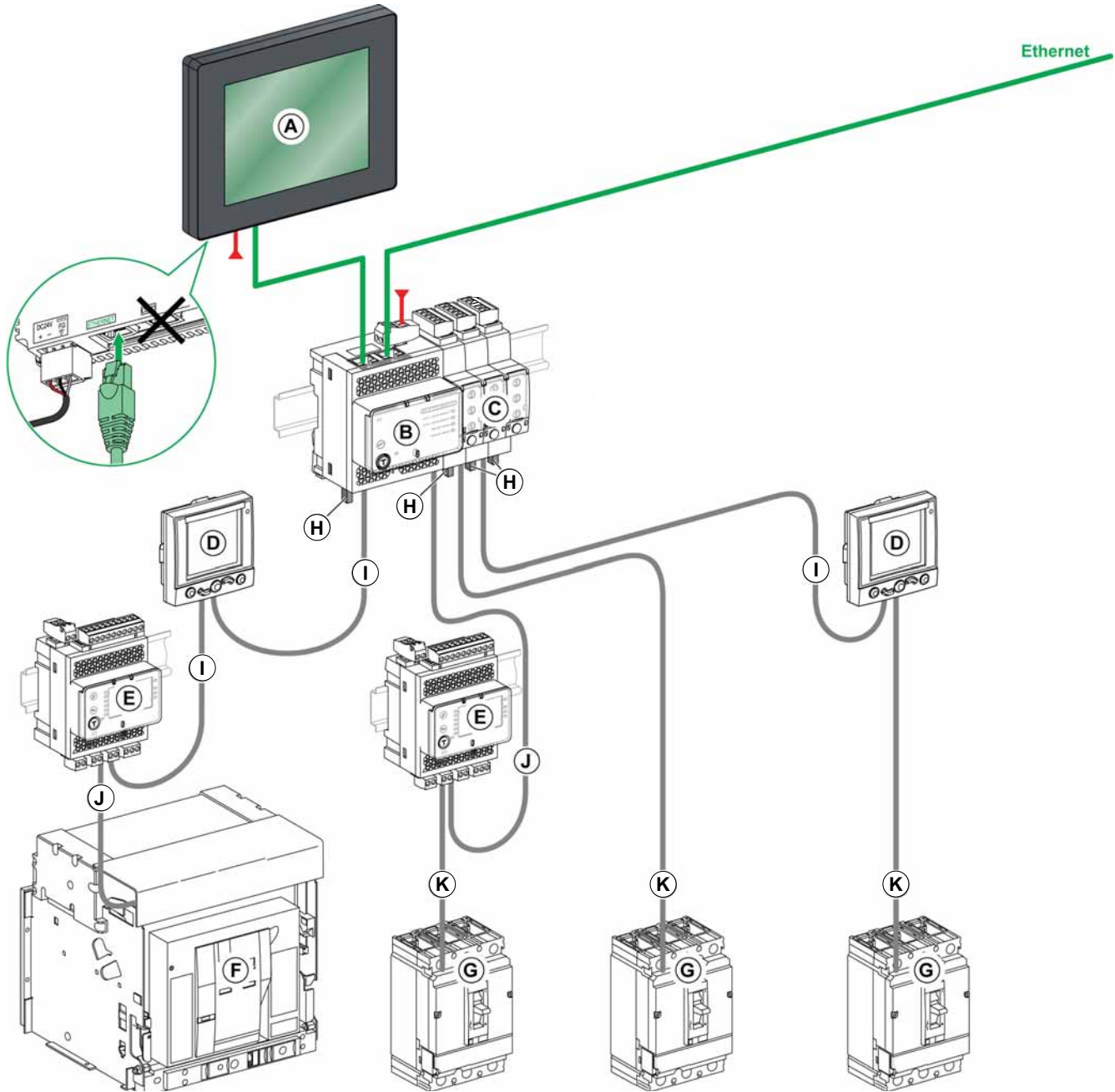

- A. FDM128 display for 8 LV devices
- B. IFE Ethernet interface for LV circuit breaker and gateway
- C. IFM Modbus-SL interface for LV circuit breaker
- D. FDM121 display for LV circuit breaker
- E. IO input/output interface module for LV circuit breaker
- F. Masterpact NT/NW circuit breaker

- G. PowerPact H-, J-, or L-frame circuit breaker
- H. ULP line terminator
- I. ULP cable
- J. Circuit breaker ULP cord
- K. NSX cord



# Masterpact™ NT and NW Universal Power Circuit Breakers Micrologic™ Electronic Trip Systems

## Four Functional Levels

The Masterpact can be integrated into Ethernet and Modbus communication environment.

There are four possible functional levels that can be combined.



A: Micrologic trip unit with ammeter

P: Micrologic trip unit "Power"

H: Micrologic trip unit "Harmonics"

**NOTE:** See the section on the Micrologic trip units for details about the trip units.

Functional Level	Switch	Circuit Breaker		
<b>Status Indications</b>				
ON/OFF (O/F) \	X	A	P	H
Spring charged	X	A	P	H
Ready to close	X	A	P	H
Fault-trip SDE	X	A	P	H
Connected / disconnected / test position CE/CD/CT (CCM only)	—	A	P	H
<b>Controls</b>				
MX1 shunt trip	X	A	P	H
XF shunt close	X	A	P	H
<b>Measurements</b>				
Instantaneous measurement information	—	A	P	H
Averaged measurement information	—	—		H
Maximum / minimum Ammeter	—	A	P	H
Energy metering	—	—	P	H
Demand for current and power	—	—	P	H
Power quality	—	—	—	H
<b>Operating Assistance</b>				
Protection and alarm settings	—	—	P	H
Histories	—	—	P	H
Time stamped event tables	—	—	P	H
Maintenance indicators	—	A	P	H

## Modbus Principle

The Modbus RS 485 (RTU protocol) system is an open bus on which communicating Modbus devices (Masterpact NW with Modbus COM, Power Meter PM700, PM800, PowerPact P/R-frame, etc.) are installed. All types of PLCs and microcomputers may be connected to the bus.

### Addresses

The Modbus communication parameters (address, baud rate, parity) are entered using the keypad on the Micrologic A, P, or H trip unit. For a switch, it is necessary to use the Electrical Asset Manager or RSU (Remote Setting Utility) Micrologic utility.

### Number of Devices

The maximum number of devices that may be connected to the Modbus bus depends on the type of device (Compact circuit breaker with Modbus COM, PM700, PM800, Masterpact circuit breaker, etc.), the baud rate (19200 is recommended), the volume of data exchanged and the desired response time. The RS 485 physical layer offers up to thirty-two connection points on the bus (one master, thirty-one slaves).

### Length of Bus

The maximum recommended length for the Modbus bus is 3940 feet (1200 meters).

### Bus Power Source

A 24 Vdc power supply is required (less than 20% ripple, insulation class II).

# Masterpact™ NT and NW Universal Power Circuit Breakers

## Micrologic™ Electronic Trip Systems

### Ethernet Principle

Ethernet is a data link and physical layer protocol defined by IEEE 802.10 and 100 Mbps specifications that connects computer or other Ethernet devices. Ethernet is an asynchronous Carrier Sense Multiple Access with Collision detection (referred as CSMA/CD) protocol. Carrier Sense means that the hosts can detect whether the medium (coaxial cable) is idle or busy.

Multiple Access means that multiple hosts can be connected to the common medium. Collision Detection means a host detects whether its transmission has collided with the transmission of another host (or hosts).

IFE Ethernet interface can be connected to a PC or a laptop over Ethernet. The maximum length of Ethernet cable is 325 feet (100 meters). IFE Ethernet interface + gateway provides a Modbus TCP/IP gateway over Ethernet to enable Modbus TCP communication from a Modbus TCP master to any Modbus slave devices connected to it. The maximum active Modbus TCP client connection is twelve.

IFE Ethernet interface has an embedded web server (web page).

### COM Option in Masterpact Circuit Breakers

All Masterpact devices can be fitted with the communication function thanks to the COM option. Masterpact uses the Ethernet or Modbus communications protocol for full compatibility with the supervision management systems.

For fixed and drawout devices, the common communication option is made up of:

- A BCM ULP module, installed behind the Micrologic trip unit and supplied with a set of switches (OF, SDE, PF and CH switches), a kit for connection to shunt close (XF) and shunt trip (MX1) communicating voltage releases, and a COM terminal block (inputs E1 to E6). This module is independent of the trip unit and receives and transmits information on the communication network. An infra-red link transmits data between the trip unit and the communication module.  
Consumption: 30 mA, 24 V.

and

- The IFM module, the Modbus interface for connection to the network, contains the Modbus address (1 to 99) declared by the user using the two dials in front. It automatically adapts (baud rate, parity) to the Modbus network in which it is installed.

or

- The IFE module, the Ethernet interface for low-voltage circuit breakers, enables an intelligent modular unit (IMU) such as a Masterpact NT/NW or PowerPact circuit breaker to be connected to an Ethernet network. Each circuit breaker has its own IFE and a corresponding IP address.

For drawout devices the Cradle Management option must be added:

The I/O (Input/Output) application module for low-voltage circuit breakers is delivered with the drawout devices ordered with the COM option for cradle management. It must be installed on a steel DIN rail that is properly grounded near the device. The I/O module must be connected to the ULP system and to the cradle position contacts (CD, CT, CE) that transmit the position of the circuit breaker in the cradle.

For communicating remote control, shunt close (XF) and shunt trip (MX1) communicating voltage releases must be added:

The shunt close (XF) and shunt trip (MX1) communicating voltage releases are equipped for connection to the communication module.

The remote-tripping function shunt trip (MX2) and undervoltage release (MN) are independent of the communication option. They are not equipped for connection to the communication module.



BCM ULP Module



I/O Application Module

# Masterpact™ NT and NW Universal Power Circuit Breakers Micrologic™ Electronic Trip Systems

Figure 10: Communication Architecture—Electrically Operated

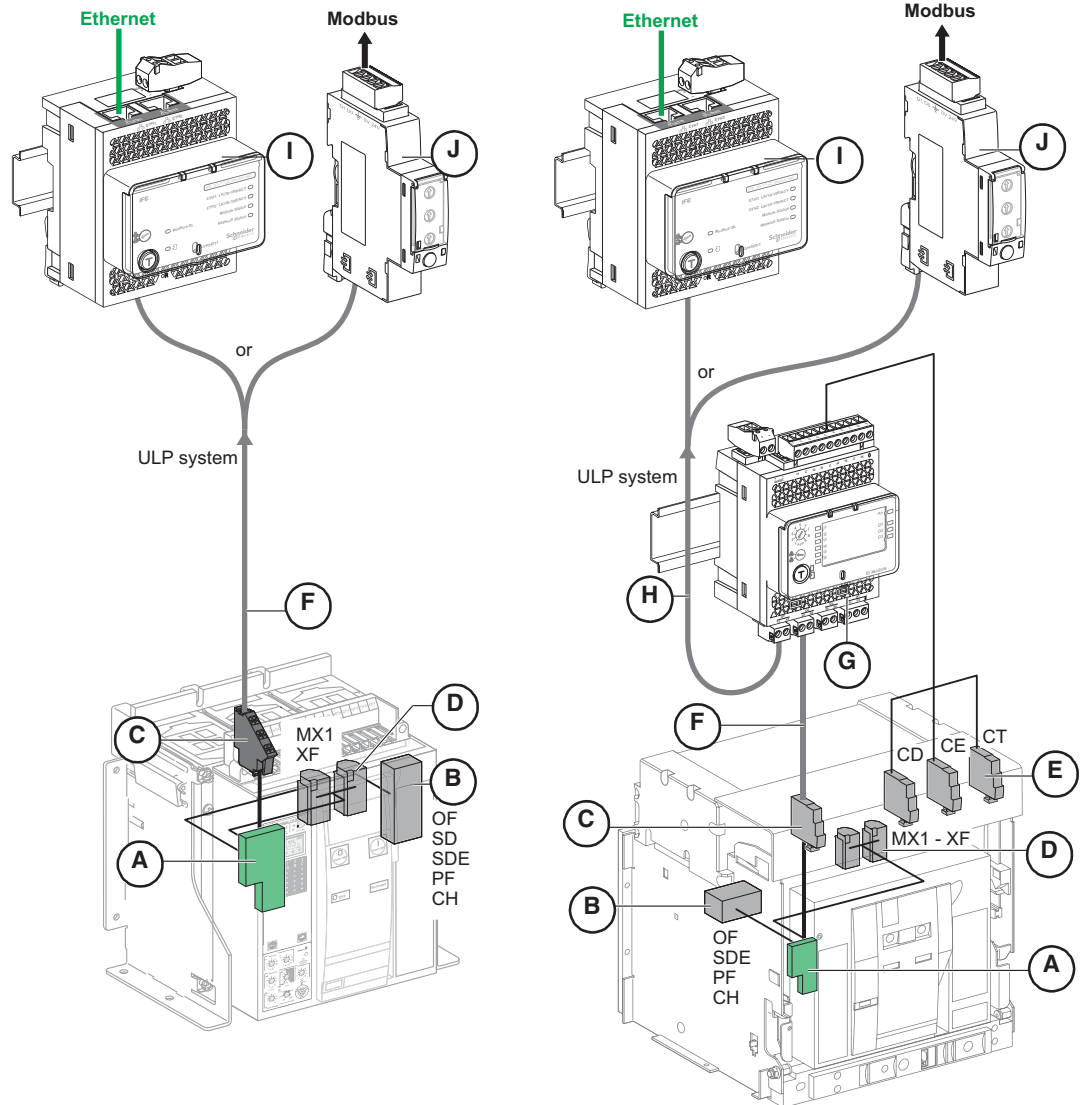

- A. BCM ULP
- B. OF, SDE, SD, PF, CH (tripped, Open/closed, overcurrent trip, ready to close, charged Switches)
- C. COM Terminal Block (E1 to E6)
- D. Shunt Trip (MX1) and Shunt Close (XF)
- E. CE, CD, and CT (connected, disconnected, test) Contacts
- F. Circuit Breaker ULP Cord
- G. I/O Application Module
- H. ULP Cable
- I. IFE Module
- J. IFM Module



# Masterpact™ NT and NW Universal Power Circuit Breakers Micrologic™ Electronic Trip Systems

## Mounting

The IFE interface and IFE interface + gateway are DIN rail mounted devices. A stacking accessory enables the user to connect several IFMs (ULP to Modbus interfaces) to an IFE interface + gateway without additional wiring.

## 24 Vdc Power Supply

The IFE interface and the IFE interface + gateway must always be supplied with 24 Vdc.

The IFMs stacked to an IFE interface + gateway have power supplied by the IFE interface + gateway, thus it is not necessary to supply them separately. It is recommended to use a UL listed and recognized limited voltage/limited current or a class 2 power supply with a 24 Vdc, 3 A maximum.

## Required Circuit Breaker Communication Modules

The connection to an IFE interface or IFE interface + gateway requires a communication module embedded into the circuit breaker:

- Masterpact NT/NW (fixed or drawout) circuit breakers: BCM ULP communication module
- Drawout Masterpact NT/NW circuit breakers: BCM ULP and its respective I/O (Input/Output) application module.

All connection configurations for Masterpact NT/NW circuit breakers require the circuit breaker ULP cord. The insulated NSX cord is mandatory for system voltages greater than 480 Vac. When the second ULP RJ45 connector is not used, it must be closed with a ULP terminator (TRV00880).

**Table 33: Network Communication Interface**

Characteristic		Value
Type of interface module		Modbus RTU, RS485 serial connection Modbus TCP/IP Ethernet
Transmission	Modbus RS485	<ul style="list-style-type: none"> <li>• Transfer rate: 9,600–19,200 Baud</li> <li>• Medium Double shielded twisted pair</li> <li>• Impedance 120 Ω</li> </ul>
	Ethernet	Transfer rate: 10/100 Mbps Medium STP, Cat5e, straight cable
Structure	Type	Modbus, Ethernet
	Method	Master/Slave
Device type	Modbus	Master
	Ethernet	Server
Turnaround time	Modbus	10 ms
	Ethernet	1 ms
Maximum length of cable	Modbus	1000 m
	Ethernet	100 m
Type of bus connector	Modbus	4-pin connector
	Ethernet	RJ45 (Shielded)

# Masterpact™ NT and NW Universal Power Circuit Breakers Micrologic™ Electronic Trip Systems

**Table 34: Characteristics**

General Characteristics	
Environmental Characteristics	
Conforming to standards	UL 508, UL 60950, IEC 60950, 60947-6-2
Certification	cUIUs, FCC, CE
Ambient temperature	Storage: -40 to +185 °F (-40 to +85 °C) Operation: -13 to +158 °F (-25 to +70 °C)
Protective Treatment	ULVO, conforming to IEC 60068-2-30
Pollution	Level 3
Mechanical Characteristics	
Shock resistance	Conforming to IEC 60068-2-27 15g/11ms, 1/2 sinusoidal
Resistance to sinusoidal vibrations	Conforming to IEC 60068-2-6
Electrical Characteristics	
Power Supply	24 Vdc, -20%/+10% (19.2 to 26.4 Vdc)
Consumption	Typical: 4 Vdc, 120 mA at 68 °F (20 °C) Maximum with gateway: 26.4 Vdc, 3 A at 140 °F (60 °C)
Physical Characteristics	
Dimensions	2.83 x 4.13 x 2.79 in. (72 x 105 x 71 mm)
Mounting	Mounting DIN rail
Weight	182.5 g (0.41 lb)
Degree of protection of the installed module	On the front panel (wall mounted enclosure): IP4x Connectors: IP2x Other parts: IP3x
Connections	Screw type terminal blocks
Technical Characteristics - 24 Vdc Power Supply	
Power supply type	Regulated switch type
Rated power	72 W
Input voltage	100–120 Vac for single phase 200–500 Vac phase-to-phase
PFC filter	With IEC 61000-3-2
Output voltage	24 Vdc
Power supply out current	3 A

IFE Web Page Description	
Monitoring Web Page	
Real time data	X
Device logging	X
Control Web Page	
Single device control	X
Diagnostics Web Page	
Statistics	X
Device information	X
IMU (circuit breaker) information	X
Read device registers	X
Communication check	X
Maintenance Web Page	
Maintenance log	X
Maintenance counters	X
Setup Web Page	
Device localization/name	X
Ethernet configuration (dual port)	X
IP configuration	X
Modbus TCP/IP filtering	X
Serial port	X
Date and time	X
E-mail server configuration	X
Alarms to be e-mailed	X
Device list	X
Device logging	X
Device log export	X
SNMP parameters	X
Documentation links	X
Preferences	X
Advanced services control	X
User accounts	X

**NOTE:** Use a UL Listed/UL Recognized limited voltage/limited current or a Class 2 power supply with a 24 Vdc, 3 A maximum.

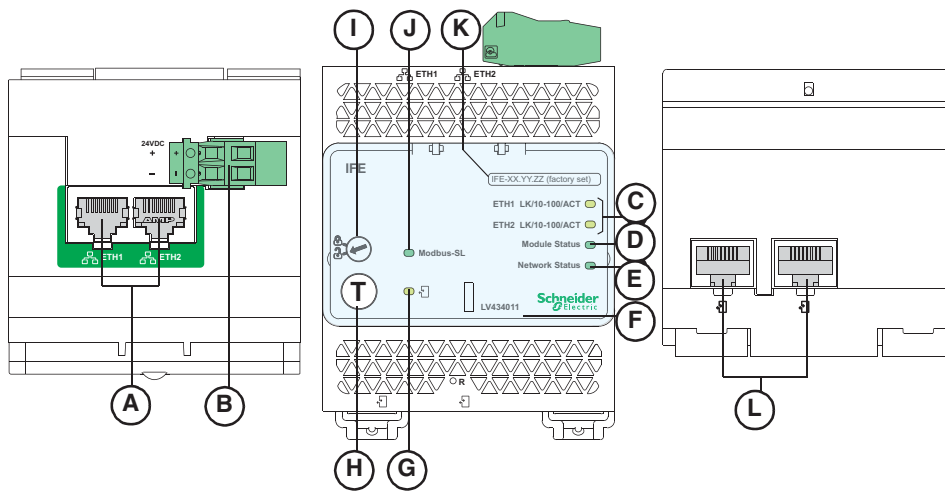

- A. Ethernet 1 and Ethernet 2 communication port
- B. 24 Vdc power supply terminal block
- C. Ethernet communication LEDs:
  - yellow: 10 Mb
  - green: 100 Mb
- D. Module status LED:
  - steady off: no power
  - steady green: device operational
  - steady red: major fault
  - flashing green: standby
  - flashing red: minor fault
  - flashing green/red: self-test
- E. Network status LED:
  - steady off: no power/no valid IP address
  - steady green: connected, valid IP address
  - steady orange: default IP address
  - steady red: duplicated IP address
  - flashing green/red: self-test
- F. Sealable transparent cover
- G. ULP status LED
- H. Test button (accessible closed cover)
- I. Locking pad
- J. Modbus traffic status LED (IFE Interface + Gateway only)
- K. Device name label
- L. ULP ports

# Masterpact™ NT and NW Universal Power Circuit Breakers Micrologic™ Electronic Trip Systems

## IFM Modbus Communication Interface

### Function

An IFM Modbus communication interface is required for connection of a Masterpact or PowerPact circuit breaker to a Modbus network as long as this circuit breaker is provided with a ULP (Universal Logic Plug) port. The port is available on the BCM ULP.

Once connected, the circuit breaker is considered as a slave by the Modbus master. Its electrical values, alarm status, open/close signals can be monitored or controlled by a Programmable Logic Controller or any other system.

### Characteristics

#### ULP Port

Two RJ45 sockets, internal parallel wiring.

- Connection of a single circuit breaker.
- A ULP line terminator or an FDM121 display unit must be connected to the second RJ45 ULP socket.
- The RJ45 sockets deliver a 24 Vdc supply fed from the Modbus socket.
- Built-in test function, for checking the correct connection to the circuit breaker and FDM121 display unit.

#### Modbus Slave Port

- Top socket for screw-clamp connector, providing terminals for:
  - 24 Vdc input supply (0 V, +24 V)
  - Modbus line (D1, D2, Gnd) 2-wire Modbus system
- Lateral socket, for DIN-rail stackable connector. Both top and lateral sockets are internally parallel wired.
- Multiple IFMs can be stacked, thus sharing a common power supply and Modbus line without individual wiring.
- On the front face:
  - Modbus address setting (1 to 99): two coded rotary switches
  - Modbus locking pad: enables or disable the circuit breaker remote control and modification of IFM parameters
- Self-adjusting communication format (Baud rate, parity).



IFM Modbus  
Communication Interface.  
Ref.: TRV00210

# Masterpact™ NT and NW Universal Power Circuit Breakers Micrologic™ Electronic Trip Systems

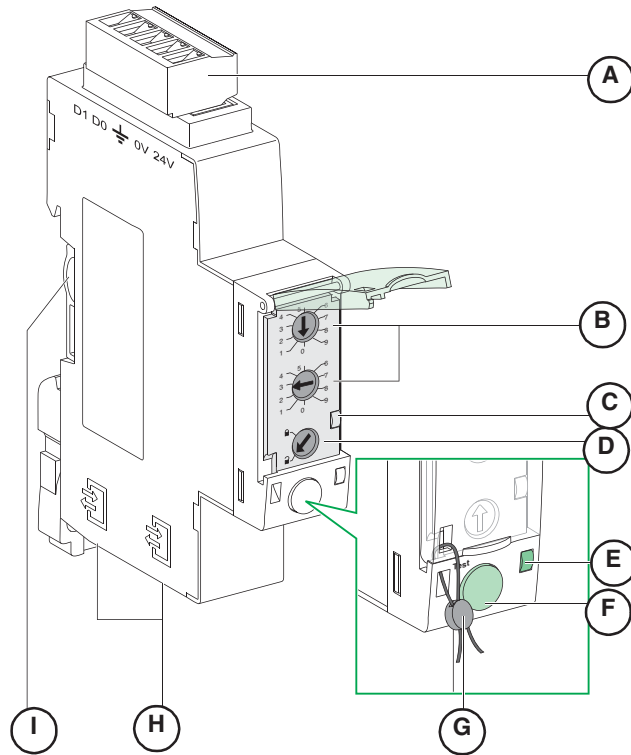

- A. Modbus Screw Clamp Connector
- B. Modbus Address Switches
- C. Modbus Traffic LED
- D. Modbus Locking Pad
- E. ULP Activity LED
- F. Test Button
- G. Mechanical Lock
- H. ULP RJ45 Connectors
- I. Stacking Accessory Connection

## Technical Characteristics

**Table 35: IFM Modbus Communication Interface**

Dimensions	0.71 x 2.83 x 3.78 in. (18 x 72 x 96 mm)	
Maximum number of stacked IFM	12	
Degree of protection of the installed module	Part projecting beyond the escutcheon	IP4x
	Other module parts	IP3x
	Connectors	IP2x
Operating temperature	-25 to +70 °C	
Power supply voltage	24 Vdc -20%/+10% (19.2–26.4 Vdc)	
Consumption	Typical	21 mA/24 Vdc at 68 °F (20°C)
	Maximum	30 mA/19.2 Vdc at 140 °F (60 °C)
Certification	CE	IEC/EN 60947-1
	UL	UL 508 - Industrial Control Equipment
	CSA	No. 142-M1987 - Process Control Equipment <ul style="list-style-type: none"> <li>• CAN/CSA C22.2 No. 0-M91 - General requirements - Canadian Electrical Code Part</li> <li>• CAN/CSA C22.2 No. 14-05 - Industrial Control Equipment</li> </ul>



# Masterpact™ NT and NW Universal Power Circuit Breakers Micrologic™ Electronic Trip Systems

## Simplified IFM Installation

### Stacking an IFM

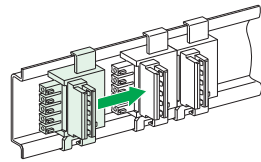

Stacking Accessories

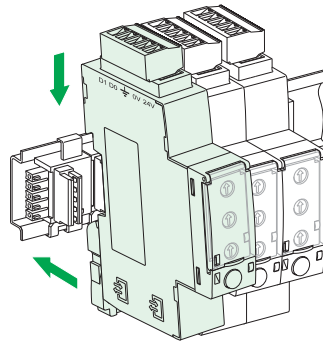

Up to 12 Stacked IFM

### Stacking an IFE Interface + Gateway with IFMs

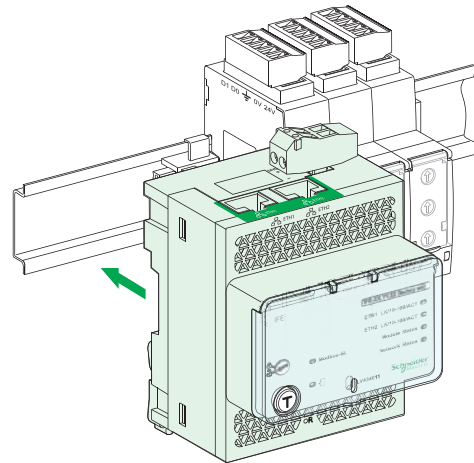
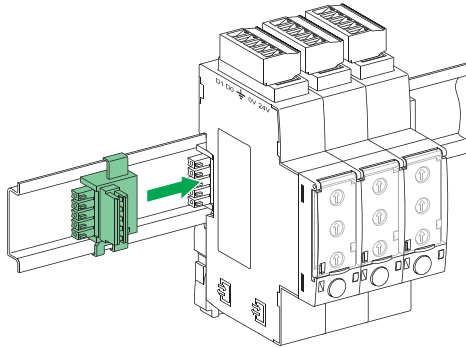

# Masterpact™ NT and NW Universal Power Circuit Breakers Micrologic™ Electronic Trip Systems

## I/O Application Module

### Description

The I/O (Input/Output) application module for an low-voltage circuit breaker is part of an ULP system with built-in functions and applications to enhance the application needs. The ULP system architecture can be built without any restrictions using the wide range of circuit breakers.

The I/O application module is compliant with the ULP system specifications.

Two I/O application modules can be connected in the same ULP network.

The ranges of low-voltage circuit breakers enhanced by the I/O application module are:

- Masterpact NW
- Masterpact NT
- PowerPact R-Frame
- PowerPact P-Frame



I/O Application Module

## I/O (Input/Output) Application Module for Low-Voltage Circuit Breaker Resources

The I/O application module resources are:

- Six digital inputs that are self powered for either NO and NC dry contact or pulse counter.
- Three digital outputs that are a bistable relay (5 A maximum).
- One analog input for PT100 temperature sensor.

### Pre-Defined Application

The pre-defined application adds new functions to the I/O application module by:

- Selection by the application rotary switch on the I/O application module, defining the application with pre-defined input/output assignment and wiring diagram.
- No additional setting with the customer engineering tool required.

The resources not assigned to the pre-defined application are free for additional user-defined applications:

- cradle management
- circuit breaker operation
- cradle management + ERMS (Energy Reduction Maintenance Setting)

**NOTE:** Use only Micrologic P or H trip units with the blue ERMS label for energy reduction maintenance setting systems. Review the I/O module user guide 0613IB1317 and ERMS installation instructions NHA67346 for details on installation, testing, and operation of the ERMS system.

- light and load control
- custom

# Masterpact™ NT and NW Universal Power Circuit Breakers Micrologic™ Electronic Trip Systems

## User-Defined Applications

User-defined applications are processed by the I/O application module in addition to the pre-defined application selected.

The user-defined applications are available depending on:

- the pre-defined application selected
- the I/O application module resources (inputs and outputs) not used by the application

The resources required by user-defined applications are assigned using the customer engineering tool:

- protection
- control
- energy management
- monitoring

## Mounting

The I/O application module is a DIN rail mounted device. Install on a steel DIN rail that is properly grounded near the device.

## Application Rotary Switch

The application rotary switch enables the selection of the pre-defined application. It has nine positions and each position is assigned to a pre-defined application. The factory set position of the switch is pre-defined application one.

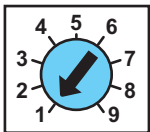

## Setting Locking Pad

The setting locking pad on the front panel of the I/O application module enables the setting of the I/O application module by the customer engineering tool.

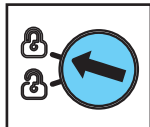
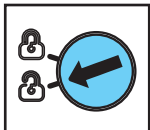

# Masterpact™ NT and NW Universal Power Circuit Breakers

## Micrologic™ Electronic Trip Systems

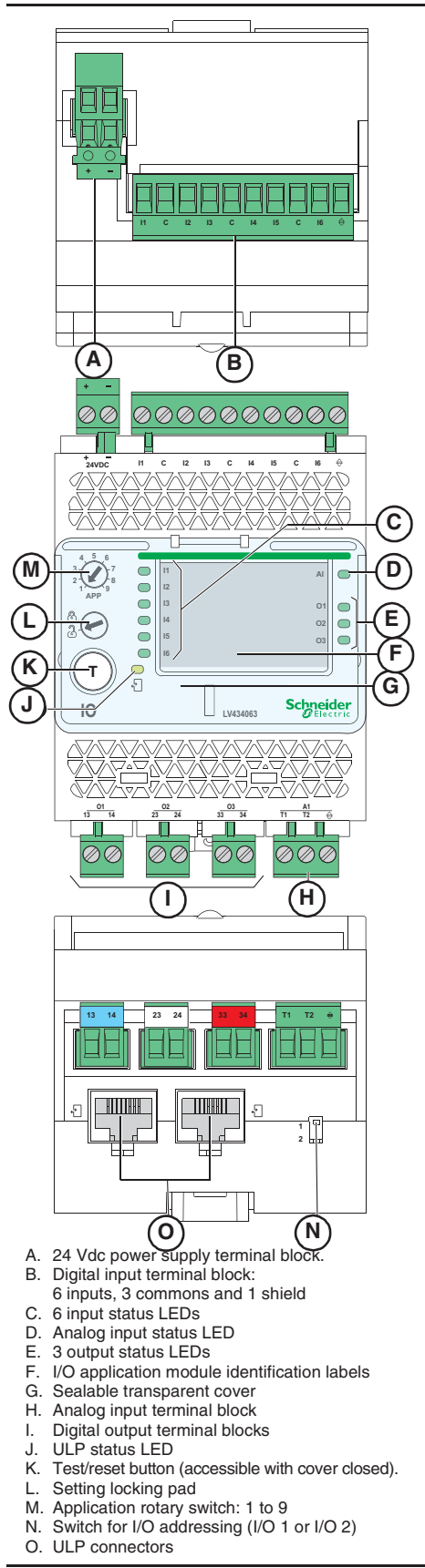

### General Characteristics

Environmental Characteristics	Conforming to standards	UL 508, UL 60950, IED 60950, 60947-6-2	
	Certification	cULus, EAC, FCC, CE	
	Ambient temperature	Storage: -40 to +185 °F (-40 to +85 °C) Operation: -13 to +158 °F (-25 to +70 °C)	
	Protective Treatment	ULVO, conforming to IEC 60068-2-30	
	Pollution	Level 3	
Mechanical Characteristics	Shock resistance	Conforming to IEC 60068-2-27 15g/11ms, 1/2 sinusoidal	
	Resistance to sinusoidal vibrations	Conforming to IEC 60068-2-6	
Electrical Characteristics	Power Supply	24 Vdc, -20%/+10% (19.2 to 26.4 Vdc)	
	Consumption	Typical: 24 Vdc, 165 mA at 20°C Maximum with gateway: 26.4 Vdc, 420 mA at 60°C	
Physical Characteristics	Dimensions	2.83 x 4.52 X 2.79 in. (72 x 115 x 71 mm)	
	Mounting	DIN rail	
	Weight	0.51 lb. (229.5 g)	
	Degree of protection of the installed I/O application module	<ul style="list-style-type: none"> <li>On the front panel (wall mounted enclosure): IP4x</li> <li>I/O parts: IP3x</li> <li>Connectors: IP2x</li> </ul>	
Technical Characteristics	Connections	Screw type terminal blocks	
	Power supply type	Regulated switch type	
	Rated power	72 W	
	Input voltage	<ul style="list-style-type: none"> <li>100–120 Vac for single phase</li> <li>200–500 Vac phase-to-phase maximum</li> </ul>	
	PFC filter	With IEC 61000-3-2	
	Output voltage	24 Vdc	
	Power supply out current	3 A	
	<b>NOTE:</b> It is recommended to use an UL listed/UL listed recognized limited voltage/limited current or a class 2 power supply with a 24 Vdc, 3 A maximum.		
	Digital Inputs	Digital input type	Self powered digital input with current limitations as per IEC 61131-2 type 2 standards (7 mA)
		Input limit values at state 1 (close)	19.8–25.2 Vdc, 6.1–8.8 mA
Input limit values at state 0 (open)		0–19.8 Vdc, 0 mA	
Maximum cable length		33 ft (10 m)	
<b>NOTE:</b> For a length greater than 10 m (33 ft) and up to 300 m (1,000 ft), it is mandatory to use a shielded twisted cable. The shield cable is connected to the I/O functional ground of the I/O application module.			
Digital Outputs	Digital output type	Bistable relay	
	Rated load	5 A at 250 Vac	
	Rated carry current	5 A	
	Maximum switching voltage	380 Vac, 125 Vdc	
	Maximum switch current	5 A	
	Maximum switching power	1250 VA, 150 W	
	Minimum permissible load	10 mA at 5 Vdc	
	Contact resistance	30 mΩ	
	Maximum operating frequency	<ul style="list-style-type: none"> <li>18000 operations/hr (Mechanical)</li> <li>1800 operations/hr (Electrical)</li> </ul>	
	Digital output relay protection by an external fuse	External fuse of 5 A or less	
Analog Inputs	Maximum cable length	10 m (33 ft)	
	The I/O application module analog input can be connected to a Pt100 temperature sensor		
	Range	-22 to 392 °F (-30 to 200 °C)	
	Accuracy	-22 to 68 °F (-30 to 20 °C): ±3.6 °F (2 °C) 68 to 284 °F (20 to 140 °C): ±1.8 °F (1 °C) 284 to 392 °F (140 to 200 °C): ±3.6 °F (2 °C)	
Refresh interval	5 s		

# Masterpact™ NT and NW Universal Power Circuit Breakers Micrologic™ Electronic Trip Systems

**Table 36: Connection of the IFE to Masterpact NT/NW**

Connect the IFE to a fixed electrically operated Masterpact NT/NW or circuit breaker using the circuit breaker ULP cord.

Connect the IFE to a drawout Masterpact NT/NW or circuit breaker using the circuit breaker ULP cord.

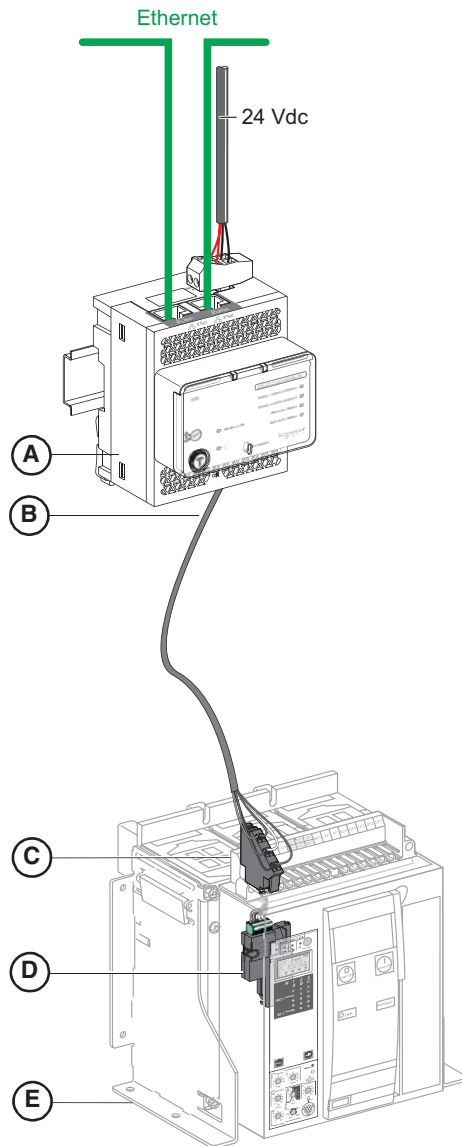

- A. IFE Ethernet interface for low-voltage circuit breaker
- B. Circuit breaker ULP cord
- C. Fixed terminal block
- D. BCM ULP communication module
- E. Fixed electrically operated circuit breaker

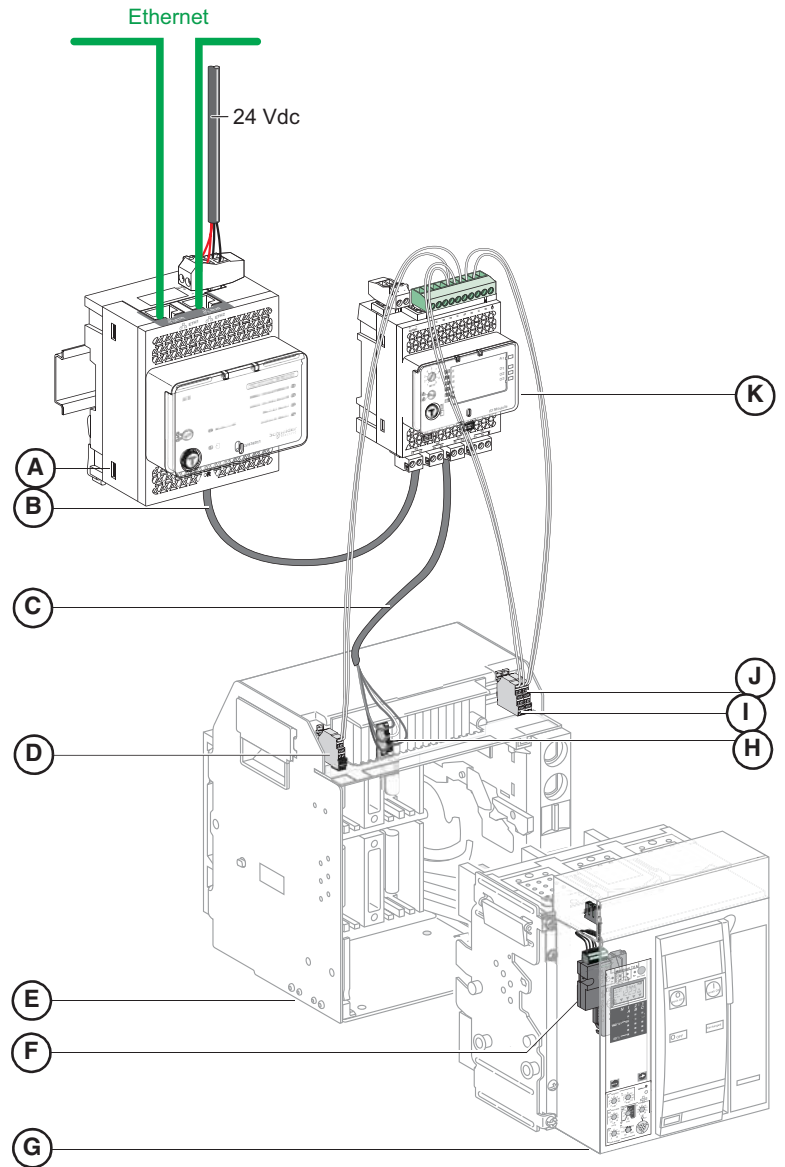

- A. IFE Ethernet interface for low-voltage circuit breaker
- B. ULP cable
- C. Circuit breaker ULP cord
- D. Circuit breaker disconnected position contact (CD)
- E. Circuit breaker cradle
- F. BCM ULP communication module
- G. Drawout circuit breaker
- H. Drawout terminal block
- I. Circuit breaker connected position contact (CE)
- J. Circuit breaker test position contact (CT)
- K. I/O (Input/Output) application module for low-voltage circuit breaker

# Masterpact™ NT and NW Universal Power Circuit Breakers Micrologic™ Electronic Trip Systems

**Table 37: Connection of the IFM to Masterpact NT/NW**

Connect the IFM to a fixed electrically-operated Masterpact NT/NW circuit breaker using the circuit breaker ULP cord.

Connect the IFM to a drawout Masterpact NT/NW circuit breaker using the circuit breaker ULP cord.

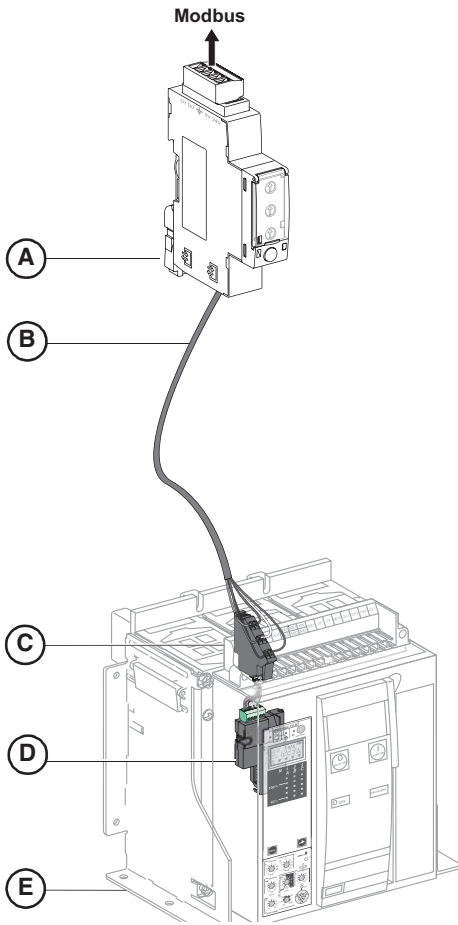

- A. IFM Ethernet interface for low voltage circuit breaker
- B. Circuit breaker ULP cord
- C. Fixed terminal block
- D. BCM ULP communication module
- E. Fixed electrically-operated circuit breaker

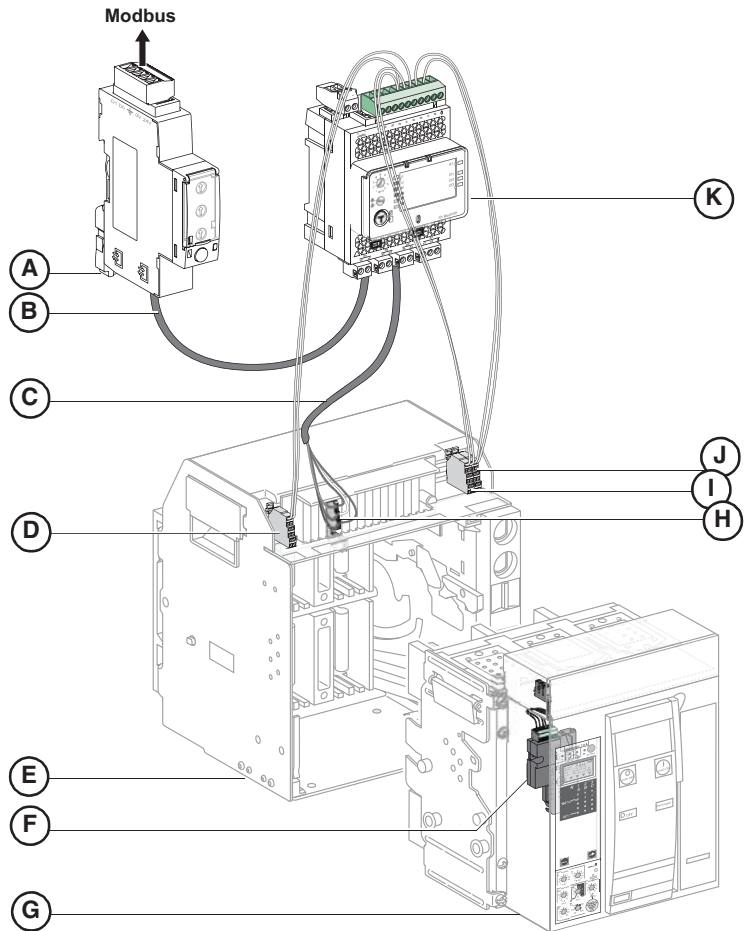

- A. IFM Ethernet interface for low voltage circuit breaker
- B. ULP cable
- C. Circuit breaker ULP cord
- D. Circuit breaker disconnected position contact (CD)
- E. Circuit breaker cradle
- F. BCM ULP communication module
- G. Drawout circuit breaker
- H. Drawout terminal block
- I. Circuit breaker connected position contact (CE)
- J. Circuit breaker test position contact (CT)
- K. I/O (Input/Output) application module for low voltage circuit breaker

# Masterpact™ NT and NW Universal Power Circuit Breakers Micrologic™ Electronic Trip Systems

## Electrical Asset Manager Configuration Engineering Tool (Ecoreach™)

### Introduction

The Ecoreach engineering tool is a software application that helps the user to manage a project as part of designing, testing, site commissioning, and maintenance of the project life cycle. It enables the user to prepare the settings of the devices offline (without connecting to the device) and configure them when connected with the devices. It also provides other value-added features for the user to manage the project such as: safe repository in cloud, attach artifacts to each device or at the project level, organize devices in switchboard, manage a hierarchical structure of the installation, etc.

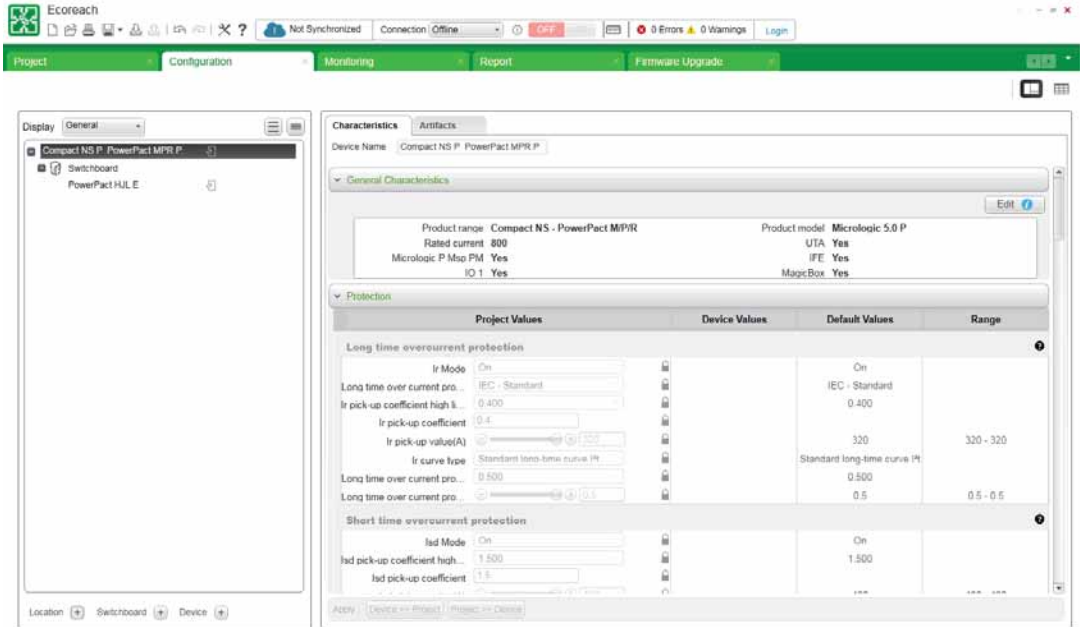

### Compatible Devices (Configuration and Device Management)

The Ecoreach engineering tool is compatible with the following devices:

- Compact NSX100-630 (IEC) circuit breakers
- PowerPact (UL) circuit breakers
- Compact NS630b-3200 (IEC) circuit breakers
- Masterpact NT/NW (IEC and UL) circuit breakers
- Compatible devices (Device Management in the project)
- Switches (Compact NSX, Masterpact & PowerPact Family)
- Third party devices

References:

The Ecoreach software package can be downloaded from our website:

[www.schneider-electric.com](http://www.schneider-electric.com)

# Masterpact™ NT and NW Universal Power Circuit Breakers

## Micrologic™ Electronic Trip Systems

### Features

The Ecoreach engineering tool includes the Schneider Electric customer engineering tools such as the Remote Setting Utility (RSU) and Remote Control Utility (RCU) with additional features.

The Ecoreach engineering tool supports the connection of Schneider Electric communicable devices to:

- create projects by device discovery, selection of devices, and importing a Bill of Material (BOM)
- monitor the status of protection and I/O status
- read information (alarms, measurements, parameters)
- check protection discrimination between two devices
- upload and download of configuration or settings in batch mode to multiple devices.
- carry out commands and tests
- generate and print a device settings report and communication test report
- manage multiple devices with a electrical and communication hierarchy model
- manage artifacts (project documents)
- check consistency in settings between devices on a communication network
- compare configuration settings between PC and device (online)
- download latest firmware

The Ecoreach engineering tool enables the user to access the advanced features of the software once the project is saved in the Schneider Electric cloud.



## Section 4—Accessories

Options for Remote Operation .....	70
Remote operation Accessories .....	70
Terminals .....	71
Spring-Charging Motor (MCH) .....	71
Shunt Trip (MX1) and Shunt Close (XF) .....	72
Additional Shunt Trip (MX2) or Undervoltage Trip (MN) .....	73
Time-Delay Module for Undervoltage Trip .....	74
Ready-to-Close Switch (PF) .....	74
Electrical Closing Push Button (BPFE) .....	75
Remote Reset (RES) and Automatic Reset After Fault Trip .....	75
Switches and Switch Accessories .....	75
Auxiliary Switch (OF) .....	75
Overcurrent Trip Switch (SDE) .....	76
Connected/Closed Switch (EF) .....	76
Cradle Position Switch .....	77
Micrologic Trip Unit Accessories .....	78
External Neutral Current Transformer (CT) .....	78
External Sensor for (SGR) and (MDGF) .....	78
Metering Current Transformers (CTs) .....	78
Voltage Measurement Inputs .....	78
Sensor Plugs .....	78
Adjustable Rating Plugs .....	78
External Power Supply Module .....	79
External Battery Backup Module .....	79
M2C/M6C Programmable Contact Modules .....	80
Zone-Selective Interlocking (ZSI) .....	80
Restraint Interface Module (RIM) .....	81
Cradle Connections .....	82
Test Equipment .....	89
Hand-Held Test Kit .....	89
Full-Function Test Kit .....	89
Circuit Breaker Locking and Interlocking .....	90
Lockable Push Button Cover .....	90
Open Position Padlock and Key Lock Provisions .....	90
Cradle Locking and Interlocking .....	91
Disconnected Position Locking .....	91
Door Interlock .....	91
Racking Interlock Between Racking Handle and Off Position .....	91
Cable Door Interlock Kit .....	91
Source Changeover Interlocks .....	92
Open Door Racking Interlock .....	92
Automatic Spring Discharge Mechanism .....	92
Cradle Rejection Kits .....	92
Rail Padlocking .....	92
Miscellaneous Accessories .....	93
Mechanical Operation Counter (CDM) .....	93
Shutter and Shutter Lock .....	93
Door Escutcheon (CDP) .....	93
Transparent Cover (CCP) for Door Escutcheon .....	93

# Masterpact™ NT and NW Universal Power Circuit Breakers Accessories

## Options for Remote Operation

Two options are available for remote operation of Masterpact circuit breakers: direct connection or a communication network.

**NOTE:** When remote operation features are used, a minimum of four seconds is required for the spring charging motor (MCH) to completely charge the circuit breaker closing springs prior to actuating the shunt close (XF) device.

The wiring diagrams for these two options are shown below.

**Figure 12: Wiring Diagram for Remote ON/OFF Function by Direct Connection**

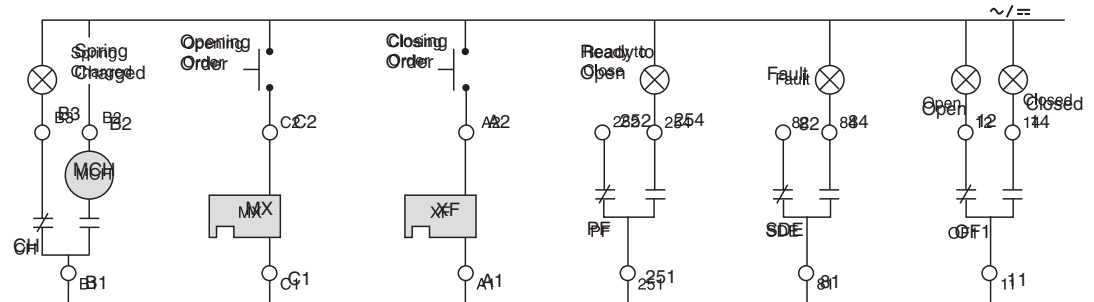

## Remote Operation Accessories

The remote ON/OFF function is used to remotely open and close the circuit breaker. It is made up of the following components:

- A spring-charging motor (MCH) equipped with a spring-charged limit switch; see page 71 for more information.
- A shunt close (XF); see page 72 for more information.
- A shunt trip (MX1); see page 72 for more information.

Optionally, the function may be completed with:

- A ready-to-close contact (PF).
- An electrical closing push button (BPFE).
- A remote reset following a fault (RES).

The remote operation function may be completed with:

- Auxiliary contacts (OF).
- Overcurrent trip switch (SDE).

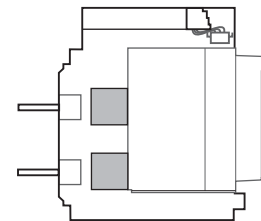

**Masterpact Circuit Breaker Equipped for Remote ON/OFF Function**  
Cluster shield is not shown

**Figure 13: Wiring Diagram for Remote ON/OFF Function by Communication Network**

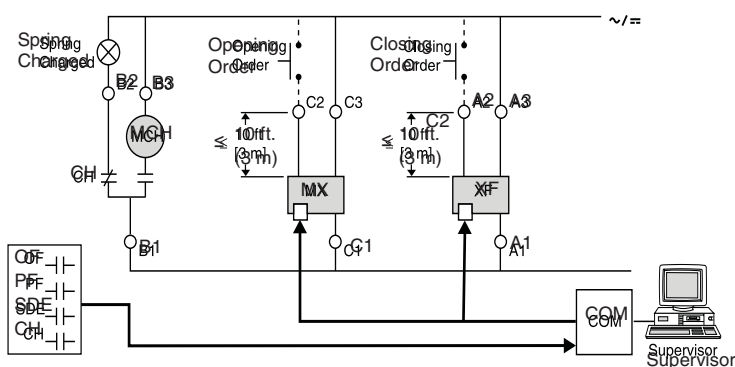

**NOTE:** Induced voltages in the circuit at terminal C2 and/or A2 can cause the shunt close to not work properly. The best way to prevent induced voltages is to keep the circuit to terminal C2 and A2 as short as possible. If it is impossible to keep the circuit less than 10 feet (3 m), use an interposing relay near terminal C2 or A2.

**NOTE:** When communicating MX1 or XF coils are used, terminal (C3 or A3) must be connected to line even if the communication module is not installed. The bypass circuit through terminal C2/A2 is only momentary duty for 0.5 sec. For continuous duty, use the communications command.

# Masterpact™ NT and NW Universal Power Circuit Breakers Accessories

## Terminals

**Table 38: Terminal Characteristics**

Standards	UL 486E	
Termination Capacity	22–14 AWG solid or stranded wire with max. O.D. of insulation 3.5 mm	
Current	Nominal	10 A
	Minimum	100mA at 24 V
Pull-Out Forces	22 AWG = 4.5 lbs. (20 N)	
	20 AWG = 6.75 lbs. (30 N)	
	18 AWG = 6.75 lbs. (30 N)	
	16 AWG = 9 lbs. (40 N)	
	14 AWG = 11.5 lbs. (50 N)	



## Spring-Charging Motor (MCH)

The spring-charging motor automatically charges the spring mechanism for closing the circuit breaker and also recharges the spring mechanism when the circuit breaker is in the ON position. Instantaneous reclosing of the circuit breaker is thus possible following circuit breaker opening. The spring-mechanism charging handle is used only as a backup if auxiliary power is absent.

The spring-charging motor is equipped as standard with a limit switch contact (CH) that signals the charged position of the mechanism (springs charged).



**Table 39: Spring-Charging Motor Characteristics**

Characteristics	MCH	
Voltage Ratings ( $V_n$ )	Vac 50/60 Hz	48/60, 100/130, 200/250, 240/277, 380/415, 400/440, 480
	Vdc	24/30, 48/60, 100/125, 200/250
Operating Threshold	0.85 to 1.1 $V_n$	
Power Consumption	180 VA	
Motor Overcurrent	2–3 x $I_n$ for 0.1 s	
Charging Time	4 s maximum on NW, 3 s maximum on NT	
Duty Cycle	3 cycles per minute maximum	
Endurance	10,000 cycles for NW < 4000 A	
	5000 cycles for NW $\geq$ 4000 A	
CH Contact	10 A at 240 V	

# Masterpact™ NT and NW Universal Power Circuit Breakers Accessories

## Shunt Trip (MX1) and Shunt Close (XF)

Maximum Wire Length—The inrush currents for these devices are approximately 200 VA. When low supply voltages (12, 24 or 48 V) are used, the maximum allowable wire length is dependent on the voltage and the wire size.

**Table 40: Maximum Wire Length<sup>1</sup>**

Device	Percent of Source Voltage	Source Voltage					
		12 Vdc		24 Vdc		48 Vdc	
Wire Size		14 AWG (2.08 mm <sup>2</sup> )	16 AWG (1.31 mm <sup>2</sup> )	14 AWG (2.08 mm <sup>2</sup> )	16 AWG (1.31 mm <sup>2</sup> )	14 AWG (2.08 mm <sup>2</sup> )	16 AWG (1.31 mm <sup>2</sup> )
UVR (MN)	100%	—	—	159 ft. (48.5 m)	100 ft. (30.5 m)	765 ft. (233.2 m)	472 ft. (143.9 m)
	85%	—	—	44 ft. (13.4 m)	29 ft. (8.8 m)	205 ft. (62.5 m)	129 ft. (39.3 m)
Shunt Trip (MX) and Shunt Close (XF)	100%	57 ft. (17.4 m)	34 ft. (10.4 m)	314 ft. (95.7 m)	200 ft. (61.0 m)	1503 ft. (457.8 m)	944 ft. (287.7 m)
	85%	27 ft. (8.2 m)	17 ft. (5.2 m)	205 ft. (62.5 m)	126 ft. (38.4 m)	957 ft. (291.7 m)	601 ft. (183.2 m)

<sup>1</sup> The length shown in the table is for each of the two supply wires.

**Shunt Trip (MX1):** When energized, the shunt trip instantaneously opens the circuit breaker. The shunt trip may be energized continuously or intermittently.

**Shunt Close (XF):** Remotely closes the circuit breaker if the spring mechanism is charged.

**NOTE:** Do not use a standing close order on the shunt close coil (XF). Any opening order will open the circuit breaker so a standing close order is not necessary. See Anti-Pump Feature on page 5.

Communication versions of the MX1 and XF are available for direct connection via the circuit breaker communication module (BCM ULP).



**Shunt Trip (MX1) and Shunt Close (XF)**

**Table 41: Shunt Trip and Shunt Close Characteristics**

Characteristics	MX1 and MX2	XF	Min	Max
Voltage Ratings (V <sub>n</sub> )		24 Vac	17 Vac	26 Vac
		48 Vac	34 Vac	52 Vac
		120 Vac	60 Vac	132 Vac
		240 Vac	168 Vac	264 Vac
		277 Vac	194 Vac	304 Vac
		380 Vac	266 Vac	418 Vac
		480 Vac	336 Vac	528 Vac
		12 Vdc	8 Vdc	13 Vdc
		24 Vdc	17 Vdc	26 Vdc
		48 Vdc	34 Vdc	52 Vdc
		125 Vdc	88 Vdc	137 Vdc
		250 Vdc	175 Vdc	275 Vdc
Operating Threshold	0.7 to 1.1 V <sub>n</sub>	0.85 to 1.1 V <sub>n</sub>		
Power Consumption (VA or W)	Steady-State/Inrush	4.5/200		
Circuit Breaker Response Time at V <sub>n</sub> <sup>1</sup>	50 ms ±10 (NW and NT)	70 ms ±10 (NW ≤ 4000 A) 80 ms ±10 (NW > 4000 A) 55 ms (NT)		

<sup>1</sup> Shunt trip (MX1) and shunt close (XF) circuits must be energized for minimum of 200 ms.

# Masterpact™ NT and NW Universal Power Circuit Breakers Accessories

## Additional Shunt Trip (MX2) or Undervoltage Trip (MN)

This function opens the circuit breaker via an electrical order.

It is made up of:

- Shunt trip (MX2, second MX) or,
- Undervoltage trip (MN)
  - Instantaneous trip
  - Fixed undervoltage trip (time delayed) or,
  - Adjustable undervoltage trip (time delayed)



Second Shunt Trip (MX2)

As shown in the wiring diagram for the remote tripping function below, the delay unit (installed outside the circuit breaker) may be disabled by an emergency off button to obtain non-delayed opening of the circuit breaker.

When energized, the shunt trip (MX1 or MX2) instantaneously opens the circuit breaker.

The undervoltage trip (MN) instantaneously opens the circuit breaker when its supply voltage drops to a value between 35% and 70% of its rated voltage.

If the undervoltage trip is not energized, it is impossible to close the circuit breaker, either manually or electrically. An attempt to close the circuit breaker produces no movement of the main contacts. Closing is allowed when the supply voltage of the undervoltage trip reaches 85% of rated voltage.

**Table 42: Undervoltage Trip Characteristics**

Characteristics		MN	
Voltage Ratings ( $V_n$ )	50/60 Hz	24 Vac	
		48 Vac	
		120 Vac	
		240 Vac	
		277 Vac	
		380 Vac	
		480 Vac	
		12 Vdc	
		24 Vdc	
		48 Vdc	
Power Consumption (VA or W)	Constant/Inrush	4.5/200	
		Operating Threshold	0.35 to 0.70 $V_n$
		Closing	0.85 $V_n$
		Circuit Breaker Response Time at $V_n$	NW
NT	40 ms $\pm$ 10		

**Figure 14: Wire Diagram for the Remote Tripping Function**

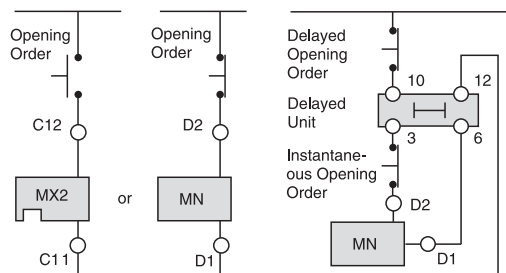

# Masterpact™ NT and NW Universal Power Circuit Breakers Accessories

## Time-Delay Module for Undervoltage Trip

To eliminate circuit breaker nuisance tripping during temporary voltage dips (micro-breaks), operation of the undervoltage trip (MN) can be delayed. This function is achieved by adding an external delay unit (either adjustable or non-adjustable) to the undervoltage trip (MN) circuit.



Time-Delay Module for Undervoltage Trip (MN)

**Table 43: Time-Delay Module Characteristics**

Voltage Ratings of Undervoltage Trip	Vac 50/60 Hz	24/30, 48/60, 100/130, 200/250, 380/480	
	Vdc	24/30, 48/60, 100/130, 200/250	
Voltage Ratings of Time-Delay Module	Adjustable	Vac 50/60 Hz	48/60, 100/130, 200/250, 380/480
		Vdc	48/60, 100/130, 200/250, 380/480
	Non-Adjustable	Vac 50/60 Hz	100/130, 200/250
		Vdc	100/130, 200/250
Operating Threshold	Opening	0.35 to 0.7 V <sub>N</sub>	
	Closing	0.85 V <sub>N</sub>	
Power Consumption		4.5 VA/W (Holding), 200 VA/W (Inrush)	
Time-Delay Settings	Adjustable	0.5, 0.9, 1.5, and 3.0 s	
	Non-Adjustable	0.25 s	

## Ready-to-Close Switch (PF)

The ready-to-close position switch indicates that the following conditions are met and the circuit breaker can be closed:

- The circuit breaker is open.
- The closing springs are charged.
- There is no standing closing or opening order.



Ready-to-Close Switch (PF)

**Table 44: Ready-to-Close Switch Characteristics**

Type of Contact	1a/1b Form C			
Maximum Number of Contacts	1			
Breaking Capacity at a Power Factor (p.f.) of 0.3	Standard: 100 mA/24V minimum load		Low-Level: 2 mA/15 V minimum load	
	240/380 Vac	5 A	24/48 Vac	3 A
	480 Vac	5 A	240 Vac	3 A
	600/690 Vac	3 A	380 Vac	3 A
	24/48 Vdc	3 A	24/48 Vdc	3 A
	240 Vdc	0.3 A	125 Vdc	0.3 A
	380 Vdc	0.15 A	250 Vdc	0.15 A

# Masterpact™ NT and NW Universal Power Circuit Breakers Accessories

## Electrical Closing Push Button (BPFE)

Located on the front panel of the circuit breaker, this push button carries out electrical closing of the circuit breaker, taking into account all of the safety functions that are part of the control/monitoring system of the installation. The push button is installed on the control circuit of the shunt close, and connects to the communicating shunt close module (XF-COM). Terminal A2 of XF-COM is used to remotely close the circuit breaker.

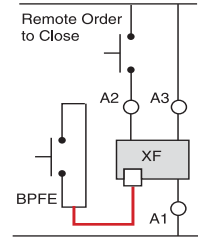

## Remote Reset (RES) and Automatic Reset After Fault Trip

- Remote reset (RES): following tripping, the remote reset (RES) resets the overcurrent trip switch (SDE) and the mechanical indicator. (Voltage rating: 110/130 Vac and 200/240 Vac.) RES is not compatible with an additional overcurrent trip switch (SDE2).
- Automatic reset after fault-trip: following tripping, a reset of the mechanical indicator (reset button) is no longer required to enable circuit breaker closing (factory adjustable only).

## Switches and Switch Accessories

### Auxiliary Switch (OF)

The rotary-type auxiliary switches are directly driven by the trip mechanism when the minimum isolation distance between the main circuit breaker contact is reached.



Auxiliary Switch (OF) with Four Contacts for Masterpact NW Circuit Breaker

Masterpact NT Aux Switch (OF) with One Contact



**Table 45: Auxiliary Switch Characteristics**

Circuit Breaker Type	NT	NW		
Supplied as Standard (Form C)	4	4		
Maximum Number of Contacts	4	12		
Standard (100 mA/24 V minimum load)				
Vac	240/380	6 A	10 A	
	480	6 A	10 A	
	600/690	6 A	6 A	
Vdc	24/48	2.5 A	10 A	
	240	0.5 A	10 A	
	380	0.3 A	3 A	
Breaking Capacity at a Power Factor (p.f.) of 0.3	Low-Level (1 mA/4 V minimum load with a maximum current and voltage of 100 mA/10 V. Note: If the maximum voltage and current is exceeded, the low-level function of the switch will be lost but the switch will continue to function as a standard switch with the following specifications.			
	Vac	24/48 Vac	5 A	6 A
		240 Vac	5 A	6 A
		380 Vac	5 A	3 A
	Vdc	24/48 Vdc	5/2.5 A	6 A
		125 Vdc	0.5 A	6 A
		250 Vdc	0.3 A	3 A

# Masterpact™ NT and NW Universal Power Circuit Breakers Accessories

## Overcurrent Trip Switch (SDE)

Circuit breaker tripping due to a fault is signalled by a red mechanical fault indicator (reset) and one overcurrent trip switch (SDE).

Following tripping, the mechanical indicator must be reset before the circuit breaker may be closed. An additional overcurrent trip switch (SDE2) is supplied as an option and is not compatible with the remote reset (RES).



**Overcurrent Trip Switch (SDE)**

**Table 46: Overcurrent Trip Switch Characteristics**

Supplied as Standard	1a/1b Form C			
Maximum Number of Contacts	2			
Breaking Capacity at a Power Factor (p.f.) of 0.3	Standard: 100 mA/24 V Minimum Load		Low-Level: 2 mA/15 V Minimum Load	
	240/380 Vac	5 A	24/48 Vac	3 A
	480 Vac	5 A	240 Vac	3 A
	600/690 Vac	3 A	380 Vac	3 A
	24/48 Vdc	3 A	24/48 Vdc	3 A
	240 Vdc	0.3 A	125 Vdc	0.3 A
	380 Vdc	0.15 A	250 Vdc	0.15 A

## Connected/Closed Switch (EF)

This switch combines the “device connected” and “device closed” information to produce “circuit closed” information. The connected/closed switch (EF) is supplied as an option and must be used with an additional auxiliary switch (OF) and fits into its connector (it is not available for ring terminals).

**Table 47: Connected/Closed Switch Characteristics**

Circuit Breaker Type	NW (not available for NT)			
Maximum Number of Contacts	8a/8b Form C			
Breaking Capacity at a Power Factor (p.f.) of 0.3	Standard: 100 mA/24 V Minimum Load		Low-Level: 2 mA/15 V Minimum Load	
	240/380 Vac	6 A	24/48 Vac	5 A
	480 Vac	6 A	240 Vac	5 A
	600/690 Vac	6 A	380 Vac	5 A
	24/48 Vdc	2.5 A	24/48 Vdc	2.5 A
	125 Vdc	0.8 A	125 Vdc	0.8 A
	250 Vdc	0.3 A	250 Vdc	0.3 A



**Connected/Closed Switch (EF) NW only**



# Masterpact™ NT and NW Universal Power Circuit Breakers Accessories

## Cradle Position Switch

Three series of optional auxiliary switches are available for the cradle:

- Cradle position switches to indicate the connected position (CE).
- Cradle position switches to indicate the disconnected position (CD). This position is indicated when the required clearance for isolation of the power and auxiliary circuits is reached.
- Cradle position switches to indicate the test position (CT). In this position, the power circuits are disconnected and the auxiliary circuits are connected.



**Cradle Position Switch (CE, CD, CT)**

**Table 48: Cradle Position Switch Characteristics**

Circuit Breaker Type	NT			NW		
	CE	CD	CT	CE	CD	CT
Maximum Push-In Switches with Standard Actuators	3	2	1	3 <sup>1</sup>	3 <sup>1</sup>	3 <sup>1</sup>
With Additional Actuators				9	0	0
				6	3	0
				3	6	0
				6	0	3
Standard (100 mA/24 V minimum load)						
Vac	240	8 A		8 A		
	380	8 A		8 A		
	480	8 A		8 A		
	600/690	6 A		6 A		
	24/48	2.5 A		2.5 A		
Vdc	125	0.8 A		0.8 A		
	250	0.3 A		0.3 A		
	Low-Level (2 mA/15 V minimum load)					
Vac	24/48	5 A		5 A		
	240	5 A		5 A		
	380	5 A		5 A		
	24/48	2.5 A		2.5 A		
Vdc	125	0.8 A		0.8 A		
	250	0.3 A		0.3 A		

<sup>1</sup> Possible Ring-Terminal Combinations		
CE	CD	CT
1b	1a	1b
1b	1a, 1b	1b
1a, 2b	1a, 2b	1a
1a, 2b	2a, 1b	1b
2a, 1b	1a, 2b	1b
1a	1a	1a
3a	3a	1a
3b	3b	1b

### Additional Actuators for Cradle Position Switches on Masterpact NW Circuit Breakers

A set of additional actuators may be installed on the cradle to change or add the functions of the cradle position switches. Each standard actuator can be replaced by any other actuator to change the function of the cradle position switch.

**Figure 15: Cradle Position Switch Actuators**



**Actuator for up to Three CE Switches (standard)**

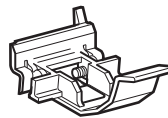

**Actuator for up to Three CD Switches (standard)**

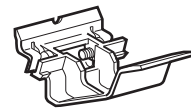

**Actuator for up to Three CT Switches (standard)**

## Micrologic Trip Unit Accessories

### External Neutral Current Transformer (CT)

The sensor is installed on the neutral conductor for neutral protection and metering and residual current ground-fault protection for equipment.

**NOTE:** The rating of the external neutral current transformer must be compatible with the rating of the circuit breaker.



### External Sensor for Source Ground-Return (SGR) and Modified Differential Ground-Fault (MDGF) Protection

**NOTE:** MDGF and SGR are for use on circuit breakers with 400 A and higher sensors.

For SGR System: The sensor is installed around the connection of the transformer neutral point to ground and connects to the Micrologic 6.0A, 6.0P or 6.0H trip units. SGR requires a modified differential ground-fault (MDGF) sensor and MDGF interface module to connect to the trip unit.

For MDGF System: An MDGF sensor is installed on each phase and neutral of each circuit breaker and connects to the Micrologic trip unit through an MDGF module. See MDGF Instruction Bulletin 48049-182.

### Metering Current Transformers (CTs)

Metering current transformers are optional and are mounted on the NW UL or ANSI cradle. They permit connection to the standard metering device. All metering transformers are accurate with the 0.3% accuracy class, 5 A output ratio at full load (for example, a 1600 A metering CT would send 5 A at the full load of 1600 A). A standard wiring harness is also included for factory-installed MCTs. Not available for neutral pole on a four-pole circuit breaker. Not available on cradles with ArcBlok technology.



### Voltage Measurement Inputs

Voltage measurement inputs are required for power measurements. As standard, the trip unit is supplied by internal voltage measurement inputs placed on the bottom terminals of the circuit breaker. On request, the internal voltage measurement inputs may be replaced by an external source.

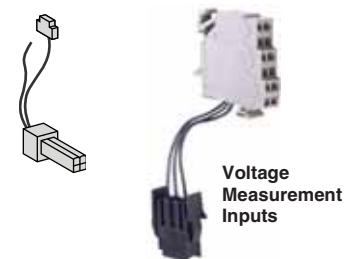

### Sensor Plugs

Sensor plugs (standard) are used to set the sensor rating ( $I_n$ ) of the circuit breaker, are field replaceable and are offered at 50–100% of frame rating. For a complete list of available sensor plugs see selection information in Section 9.



# Masterpact™ NT and NW Universal Power Circuit Breakers Accessories

## Adjustable Rating Plugs

Eight interchangeable rating plugs are available to limit the long-time threshold setting range for greater versatility.



Adjustable Rating Plug

**Table 49: Adjustable Rating Plug Settings**

Rating Plug	Switch Settings $I_r = I_n \times \dots$									
UL Listed/ANSI Certified	Type A <sup>1</sup>	0.4	0.45	0.5	0.6	0.63	0.7	0.8	0.9	1
	Type B	0.4	0.44	0.5	0.56	0.63	0.75	0.88	0.95	1
	Type C	0.42	0.50	0.53	0.58	0.67	0.75	0.83	0.95	1
	Type D	0.4	0.48	0.64	0.7	0.8	0.9	0.93	0.95	1
	Type E	0.6	0.7	0.75	0.8	0.85	0.9	0.93	0.95	1
	Type F	0.84	0.86	0.88	0.9	0.92	0.94	0.96	0.98	1
	Type G	0.66	0.68	0.7	0.72	0.74	0.76	0.78	0.8	0.82
	Type H	0.48	0.5	0.52	0.54	0.56	0.58	0.6	0.62	0.64
IEC Rated	Type R <sup>1</sup>	0.4	0.5	0.6	0.7	0.8	0.9	0.95	0.98	1
	Type S	0.4	0.45	0.5	0.55	0.6	0.65	0.7	0.75	0.8
	Type T	0.8	0.82	0.85	0.88	0.9	0.92	0.95	0.98	1
	Type P (off plug)	No long-time protection.								

<sup>1</sup> Standard

## External Power Supply Module

Power supply modules are available in six input voltages: 24/30 Vdc, 48/60 Vdc, 125 Vdc, 110/130 Vac, 200/240 Vac, and 380/415 Vac (all +10%, -15%). The output voltage for each is 24 Vdc; the output power is 5 VA/5 W (ripple < 5%). The modules are not UL Listed.



External Power Supply Module

When used with the Micrologic A, P, and H trip units, a power supply module makes it possible to:

- Display currents less than 20% of sensor ( $I_n$ ).
- Maintain display of tripping causes after opening of the circuit breaker (P and H trip units only).
- Store the value of the interrupted current (P and H trip units only).
- Power the M2C module (P and H trip units only).

## External Battery Backup Module

The external battery backup module provides up to 12 hours of backup power for the power supply module.



External Battery Backup Module

# Masterpact™ NT and NW Universal Power Circuit Breakers Accessories

## M2C/M6C Programmable Contact Modules

These contacts are used with the Micrologic P and H control units, and indicate the type of fault and instantaneous or delayed threshold overruns (i.e trip unit protection pick-up, current/voltage unbalance, under/over voltage, reverse power, phase rotation, under/over frequency, and load shedding). The M2C unit is powered from the control unit's 24 Vdc source (100 mA consumption); the M6C unit requires an external 24 Vdc power supply (100 mA consumption).

They are programmed via the control unit using a keypad or via a supervisory station with the COM communication option. They may be programmed:

- with instantaneous return to the initial state;
- without return to the initial state;
- with return to the initial state following a delay.



M6C Programmable Contact Module



M2C Programmable Contact Module

**Table 50: Characteristics for M2C/M6C Programmable Contacts**

Minimum Load	100 mA/24 V
240 Vac	5 A
380 Vac	3 A
Breaking Capacity at a Power Factor (p.f.) of 0.7	
24 Vdc	1.8 A
48 Vdc	1.5 A
125 Vdc	0.4 A
250 Vdc	0.15 A

## Zone-Selective Interlocking (ZSI)

Zone-selective interlocking (ZSI) is used to reduce the stress on electrical distribution equipment during fault conditions by reducing the time it takes to clear the fault, while maintaining system coordination between overcurrent protective devices.

During a short-circuit or ground-fault condition on a ZSI system, the device directly ahead of the fault sends a signal upstream via control wiring to restrain upstream circuit breakers from tripping and then trips with no intentional time delay to clear the fault. Upstream devices which receive a restraint signal obey their short-time and/or ground-fault delay settings to maintain coordination in other areas of the system. Upstream devices that do not receive a restraint signal trip with no intentional time delay.

For ZSI to work, trip settings must be coordinated so a downstream circuit breaker will trip before an upstream circuit breaker under overload, short-circuit or ground-fault conditions. (Effective coordination requires a system coordination study.)

### Example of Zone-Selective Interlocking

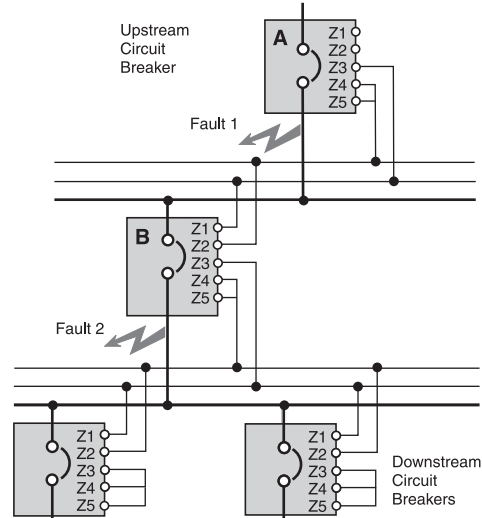

**Fault 1**—The upstream circuit breaker (A) will clear the fault with no intentional delay, regardless of its time-delay setting.

**Fault 2**—Circuit breaker (B) will inform upstream circuit breaker (A) that it is clearing the fault. This will prevent circuit breaker (A) from tripping instantaneously. Circuit breaker (A) will trip at the end of its time delay setting if the fault is not cleared during this time.

# Masterpact™ NT and NW Universal Power Circuit Breakers Accessories

## Restraint Interface Module (RIM)

The restraint interface module (RIM) is used to allow zone-selective interlocking communications between circuit breakers with old Square D Micrologic, Merlin Gerin™, or Federal Pioneer™ trip units and GC series ground-fault relays.

Downstream circuit breakers with Micrologic 2.0A, 5.0A, 5.0P, 5.0H, 6.0A, 6.0P, and 6.0H trip units can restrain up to 15 upstream circuit breakers with Micrologic 5.0A, 5.0P, 5.0H, 6.0A, 6.0P and 6.0H trip units without requiring a restraint interface module. If the number of upstream circuit breakers exceeds 15, then a RIM is required.



Restraint Interface Module (RIM)

**Table 51: RIM Requirements**

Downstream Device (sends output to RIM)	Upstream Device (receives output to RIM)	Micrologic Trip Unit <sup>1</sup>	Micrologic Series B Trip Unit	Square D GC-100 Relay	Square D GC-200 Relay	Merlin Gerin STR58 Trip Units	Federal Pioneer USRC and USRCM Trip Units
Micrologic Trip Unit <sup>1</sup>		15 <sup>2</sup>	R	R	15	15	R
Square D Micrologic Series B Trip Units		R	26	R	R	R	15
Square D GC-100 Relay		R	R	7	R	R	R
Square D GC-200 Relay		15	R	R	15	15	R
Merlin Gerin STR58 Trip Units		15	R	R	15	15	R
Merlin Gerin STR53 Trip Units		15	R	R	15	15	R
Federal Pioneer USRC and USRCM Trip Units		R	15	R	R	R	15
Square D Add-On Ground Fault Module for Equipment Protection		R	5	R	R	R	R

**R** Denotes that a Restraint Interface Module (RIM) is required.

<sup>1</sup> Includes 2.0A (as a downstream trip unit only), 5.0A, 5.0P, 5.0H, 6.0A, 6.0P, and 6.0H trip units.

<sup>2</sup> Number denotes maximum number of upstream circuit breakers that can be restrained without requiring a RIM.

# Masterpact™ NT and NW Universal Power Circuit Breakers Accessories

## Cradle Connections

**Table 52: Masterpact NW UL Listed/ANSI Certified 3P/4P Drawout Circuit Breakers (Rear Connections)**

Connector Type	Ampere Rating	3P Layout (Back/Side/Top)	4P Layout (Back/Side/Top)
Rear-Connected "T" Vertical (RCTV)	800 to 2000 A		
	2500 to 3000 A		
	3200 A (L1) 4000 to 5000 A		
	6000 A		
Rear-Connected "T" Horizontal (RCTH)	800 to 2000 A		
	2500 to 3000 A		
	3200 A (L1) 4000 to 5000 A		
Rear-Connected Offset Vertical (RCOV)	3200 A 2000 A (L1/L1F)		

# Masterpact™ NT and NW Universal Power Circuit Breakers Accessories

**Table 53: Masterpact NW UL Listed/ANSI Certified 3P/4P Drawout Circuit Breakers (Front Connections)**

Connector Type	Ampere Rating	3P Layout (Back/Side/Top)	4P Layout (Back/Side/Top)
Front-Connected Flat (FCF)	800 to 2000 A		
	3200 A (L1) 4000 A		
Front-Connected "T" (FCT)	800 to 3000 A		
	3200 A (L1) 4000 to 5000 A		

**Table 54: Masterpact NW UL Listed/ANSI Certified 3P/4P Fixed Circuit Breakers (Rear Connections)**

Connector Type	Ampere Rating	3P Layout (Back/Side/Top)	4P Layout (Back/Side/Top)
Rear-Connected "T" Vertical (RCTV)	800 to 2000 A		
	2500 to 3000 A		
	4000 to 5000 A		
	6000 A		

*Continued on next page*

# Masterpact™ NT and NW Universal Power Circuit Breakers Accessories

**Table 54: Masterpact NW UL Listed/ANSI Certified 3P/4P Fixed Circuit Breakers (Rear Connections) (continued)**

Rear-Connected "T" Horizontal (RCTH)	800 to 2000 A	
	2500 to 3000 A	
	4000 to 5000 A	
Rear-Connected Offset Vertical (RCOV)	3200 A	
Rear-Connected Offset Vertical (Special)	4000 A (B) (W-Frame)	

**Table 55: Masterpact NW UL Listed/ANSI Certified 3P/4P Fixed Circuit Breakers (Front Connections)**

Connector Type	Ampere Rating	3P Layout (Front/Side/Top)	4P Layout (Front/Side/Top)
Front-Connected Flat (FCF)	800 to 2000 A		
Front-Connected "T" (FCT)	800 to 3000 A		



# Masterpact™ NT and NW Universal Power Circuit Breakers Accessories

**Table 56: Masterpact NW IEC Rated 3P/4P Drawout Circuit Breakers**

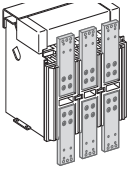
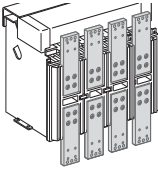
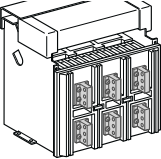
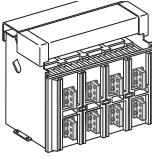
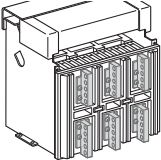
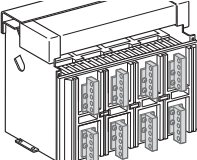
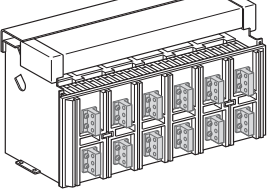
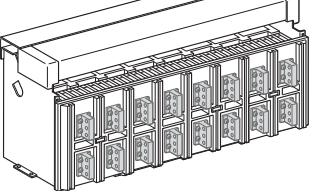
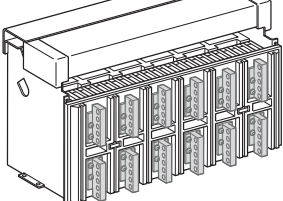
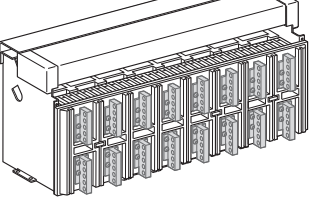
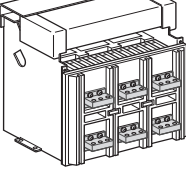
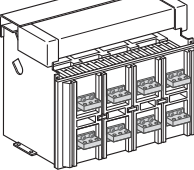
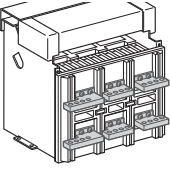
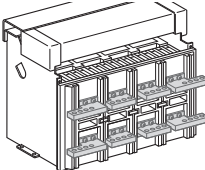
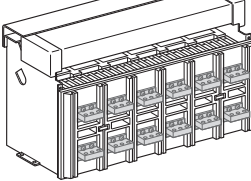
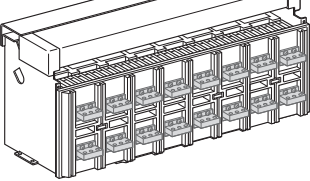
Connector Type	Ampere Rating	3P Layout	4P Layout
Front-Connected Flat (FCF)	800 to 3200 A		
	800 to 3200 A		
Rear-Connected "T" Vertical (RCTV)	4000 A		
	5000 A		
	6300 A		
	800 to 3200 A		
Rear-Connected "T" Horizontal (RCTH)	4000 A		
	4000b, 5000 A		

# Masterpact™ NT and NW Universal Power Circuit Breakers Accessories

**Table 57: Masterpact NW IEC Rated 3P/4P Fixed Circuit Breakers**

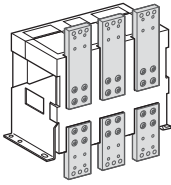
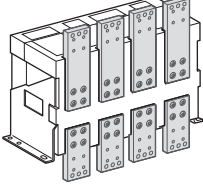
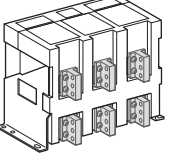
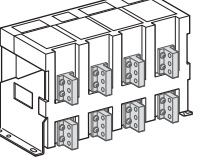
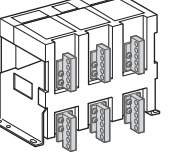
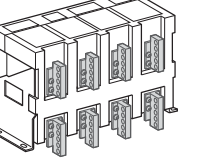
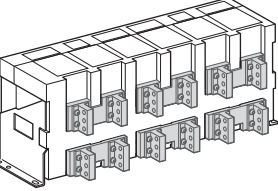
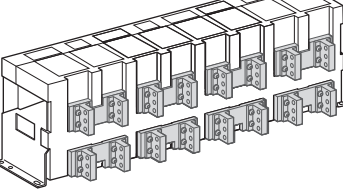
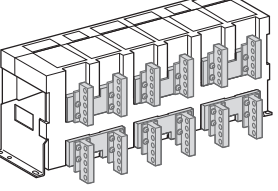
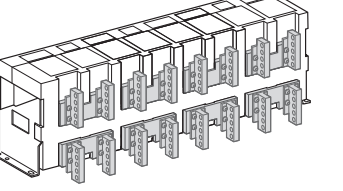
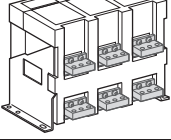
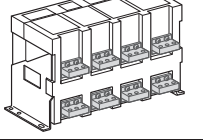
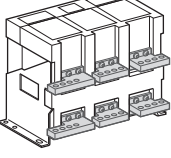
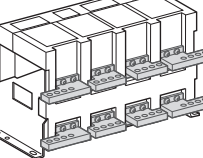
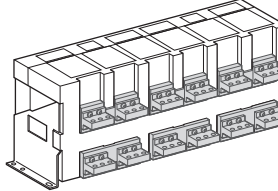
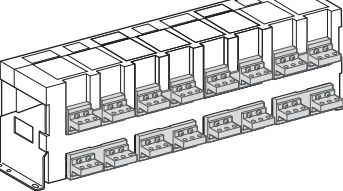
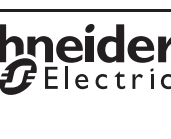
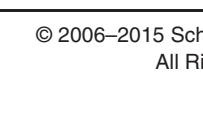
Connector Type	Ampere Rating	3P Layout	4P Layout
Front-Connected Flat (FCF)	800 to 3200 A		
	800 to 3200 A		
Rear-Connected "T" Vertical (RCTV)	4000 A		
	4000b, 5000 A		
	6300 A		
	800 to 3200 A		
Rear-Connected "T" Horizontal (RCTH)	4000		
	4000b, 5000 A		
	800 to 3200 A		

# Masterpact™ NT and NW Universal Power Circuit Breakers Accessories

**Table 58: Masterpact NT UL Listed/ANSI Certified 3P/4P Fixed and Drawout Circuit Breakers**

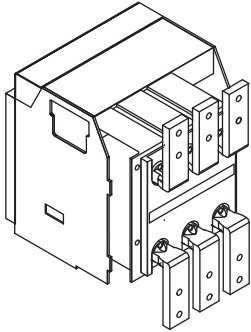
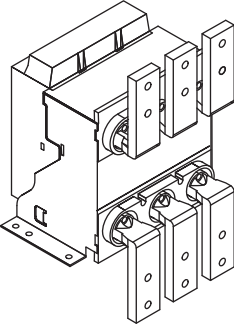
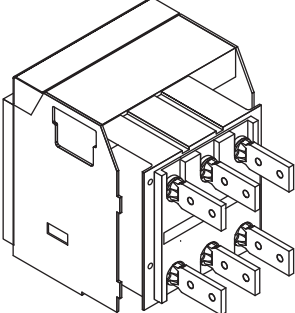
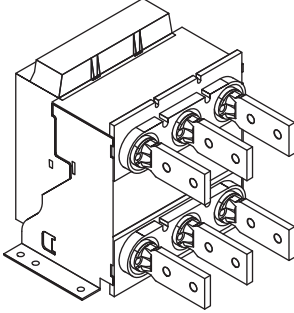
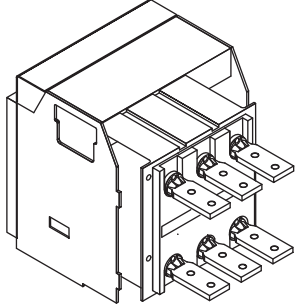
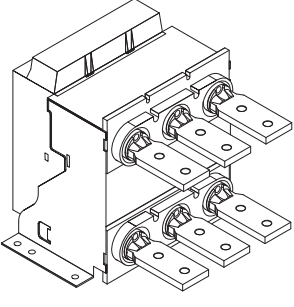
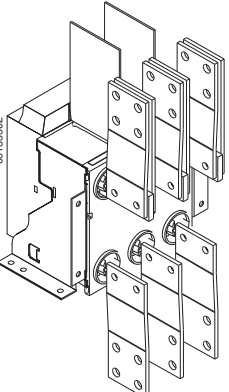
Connector Type	Drawout Circuit Breakers	Fixed Circuit Breakers
<p>Front-Connected Flat (FCF) 800 to 1200 A</p>		
<p>Rear-Connected "T" Vertical (RCTV) 800 to 1200 A</p>		
<p>Rear-Connected "T" Horizontal (RCTH) 800 to 1200 A</p>		
<p>Rear-Connected Vertical 1600 A</p>	<p>N/A</p>	

# Masterpact™ NT and NW Universal Power Circuit Breakers Accessories

**Table 59: Masterpact NT IEC Rated 3P/4P Fixed and Drawout Circuit Breakers**

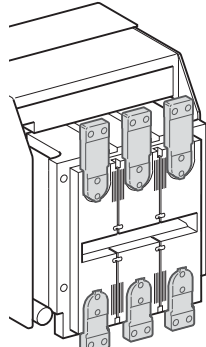
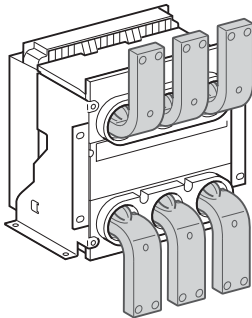
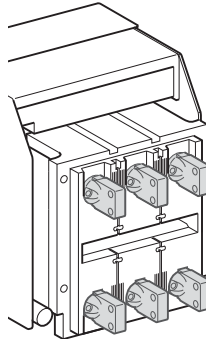
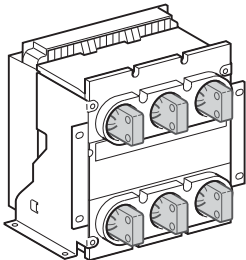
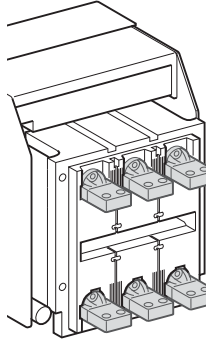
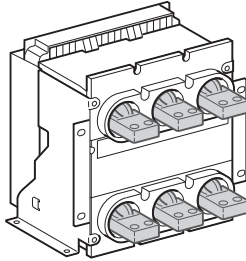
Connector Type	Drawout Circuit Breakers	Fixed Circuit Breakers
<p>Front-Connected Flat (FCF) 800 to 1600 A</p>		
<p>Rear-Connected "T" Vertical (RCTV) 800 to 1600 A</p>		
<p>Rear-Connected "T" Horizontal (RCTH) 800 to 1600 A</p>		

## Test Equipment

### Hand-Held Test Kit

The hand held test kit may be used to:

- Verify trip unit operation, the mechanical operation of the circuit breaker, and the electrical continuity of the connection between the trip solenoid and the trip unit.
- Supply control power to the trip unit for settings via the keypad when the circuit breaker is open (Micrologic type A, P or H trip units).
- Inhibit thermal imaging for primary injection test (Micrologic type A, P or H trip units).
- Inhibit ground fault for primary injection test (Micrologic type A, P or H trip units).
- Self-restrain zone-selective interlocking (ZSI).



Hand-Held Test Kit

### Full-Function Test Kit

The full-function test kit can be used to verify LSIG functionality.

- Optional
- Can be used to check trip unit operation, for example:
  - Display of settings.
  - Operating tests on the electronic component.
  - Automatic and manual tests on protection functions (trip curve verification).
  - Tests on the zone-selective interlocking (ZSI) functions.
  - Inhibit thermal imaging for primary injection testing.
  - Self-restrain zone-selective interlocking (ZSI).
- Can also be used to:
  - Check mechanical operation of the circuit breaker.
  - Check the electrical continuity of connection between the trip solenoid and the trip unit.
  - Print the trip unit and circuit breaker test report when used in conjunction with a PC FFTK report generator software (cat. no. FFTKRPT-V1-0) is required.



Full-Function  
Test Kit

## Circuit Breaker Locking and Interlocking

### Lockable Push Button Cover

A transparent cover blocks access to the push buttons used to open and close the device. It is possible to independently lock the opening button and/or the closing button. The push buttons may be locked using:

- One to three padlocks: 3/16 to 5/16 in. (4.8 to 7.9 mm) diameter, not supplied
- Wire seal
- Two screws

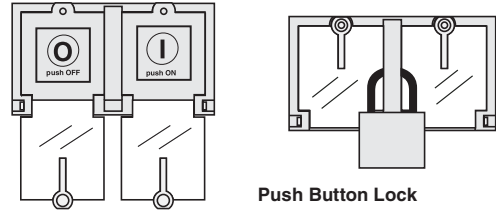

### Open Position Padlock and Key Lock Provisions

The circuit breaker is locked in the off position by physically keeping the opening push button pressed down using one of the following:

- One to three padlocks: 3/16 to 5/16 in. (4.8 to 7.9 mm) diameter, not supplied.
- Key locks: One or two Kirk® key locks (keyed alike or differently) are available for UL Listed/ANSI Certified circuit breakers; for IEC Rated circuit breakers, Ronis, Castell, or Profalux key locks are available. (Masterpact NT circuit breakers may have only one key lock on the circuit breaker.)



**Open Position Key Lock (NW)**



**Open Position Padlock Provision (NW)**

Keys may be removed only when locking is effective. The key locks are available in any of the following configurations:

- One key lock
- One key lock mounted on the device plus one identical key lock supplied separately for interlocking with another device
- Two different key locks mounted on the circuit breaker for double locking

A locking kit for installation of one or two key locks may be ordered separately.

**Table 60: Circuit Breaker and Switch Locking Options**

Type of Locking		Maximum Number of Locks
Pushbutton Locking	Using padlocks	Three padlocks
	Using key locks	Two key locks (optional)
Open Position Locking	Using padlocks and key locks	Up to three padlocks and two key locks (optional)

## Cradle Locking and Interlocking

### Disconnected Position Locking

The circuit breaker can be locked in the disconnected position by key interlock (optional) or padlock (standard). The key interlock is on the cradle and accessible with the door locked.

- Kirk key interlocks are available for UL/ANSI circuit breakers; for IEC circuit breakers, Ronis, Castell, or Profalux key locks are available. Key is captive when key interlock is unlocked.
- Locking on disconnected, test, and connected positions is optional for IEC circuit breakers and standard for UL/ANSI circuit breakers.

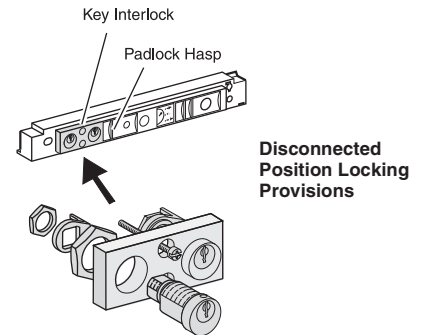

### Door Interlock (VPEC)

The door interlock prevents the compartment door from being opened when the circuit breaker is in the connected or test position. If the circuit breaker is put into the connected position with the door open, the door can be closed without disconnecting the circuit breaker. For greater protection, this interlock can be used in conjunction with the open door racking interlock.

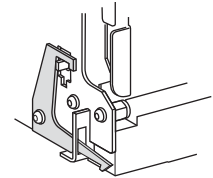

### Racking Interlock Between Racking Handle and Off Position (IBPO)

The racking interlock is standard for UL and ANSI circuit breakers, and optional for IEC circuit breakers. It prevents insertion of the racking handle unless the OFF push button is pressed. Not available for IEC Rated Masterpact NT circuit breakers.

### Cable Door Interlock Kit

The optional cable door interlock prevents the compartment door from being opened when the circuit breaker is in the closed position. This kit includes:

**Figure 16: Cable Door Interlock Kit Contents**

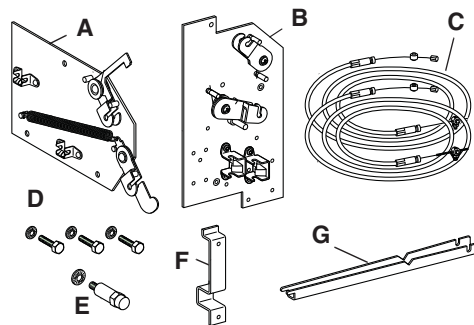

**Kit Contents**

- (A) Panel Interlocking Plate
- (B) Circuit Breaker Interlocking Plate
- (C) Interlocking Cables
- (D) Bolts with Washers
- (E) Guide-Bolt with Washer
- (F) Interlocking Bracket
- (G) Calibration Tray



# Masterpact™ NT and NW Universal Power Circuit Breakers Accessories

## Source Changeover Interlocks

Source changeover interlocks allow mechanical interlocking between two or three circuit breakers (fixed and drawout).

**NOTE:** Source changeover interlocks for Masterpact NT circuit breakers are IEC only.

**Figure 17: Source Changeover Interlocks**

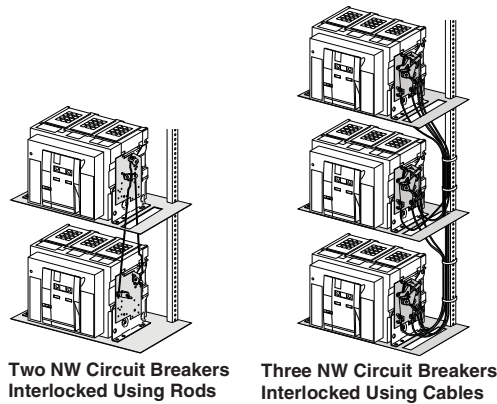

### Interlocking Two Circuit Breakers

- Interlocking Two Mains Using Rods
- Interlocking Two Mains Using Cables

### Interlocking Three Circuit Breakers Using Cables

- Interlocking Two Mains and One Generator
- Interlocking Two Mains and One Tie
- Interlocking Three Mains

## Open Door Racking Interlock (VPOC)

The racking interlock prevents racking in the circuit breaker when the door is open. (Insertion of the circuit breaker racking handle is not possible when the compartment door is open.)



Open Door Racking Interlock (NW)

## Automatic Spring Discharge Mechanism (DAE)

The automatic spring discharge mechanism is standard for UL and ANSI circuit breakers, and optional for IEC circuit breakers. It releases the closing spring energy when the circuit breaker is moved from the disconnected position to the fully withdrawn position. Not available for IEC Rated Masterpact NT circuit breakers.

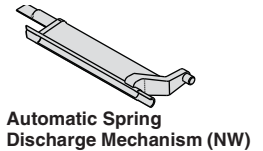

Automatic Spring Discharge Mechanism (NW)

## Cradle Rejection Kits

The cradle rejection feature (standard) ensures that only the properly designated circuit breaker or switch is matched with the selected cradle assembly.

**Figure 18: Cradle Rejection Kits**

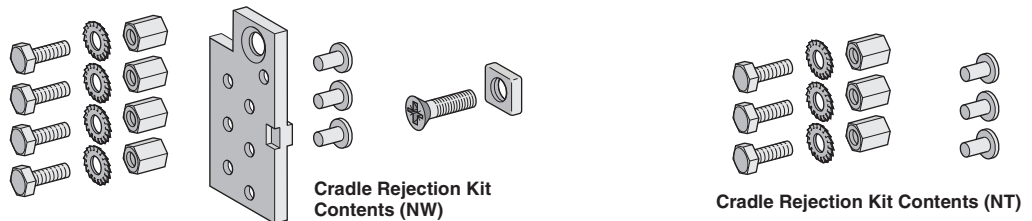

## Rail Padlocking

Rail padlocking is standard for UL, ANSI, and IEC cradles. When used in combination with the disconnected position locking device, rail padlocking prevents the movement of the circuit breaker from the disconnected position to the fully withdrawn position when the padlock hasp is pulled out and locked.



## Miscellaneous Accessories

### Mechanical Operation Counter (CDM)

The mechanical operation counter (CDM) registers the total number of operating cycles. One CDM is installed per circuit breaker.



### Shutter and Shutter Lock

The shutters automatically block access to the main disconnects when the circuit breaker is in the disconnected, test, or fully withdrawn position.

The shutter lock is used to prevent connection of the circuit breaker or to lock the shutters in the closed position.

Not available on cradles with ArcBlok technology.

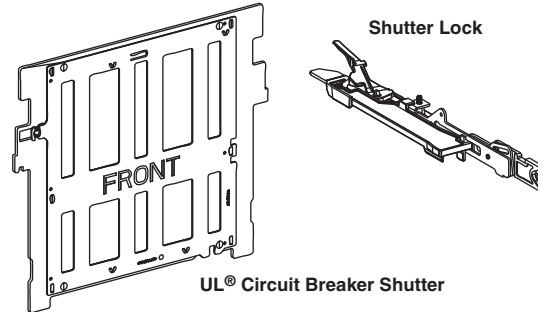

### Door Escutcheon (CDP)

These door escutcheons provide a frame and seal for the circuit breaker.

Figure 19: Door Escutcheons

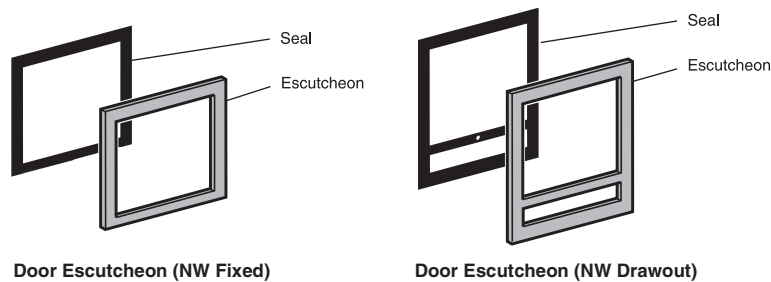

### Transparent Cover (CCP) for Door Escutcheon

The cover is hinged-mounted and locked with a milled head, and is designed to be installed on the door escutcheon.

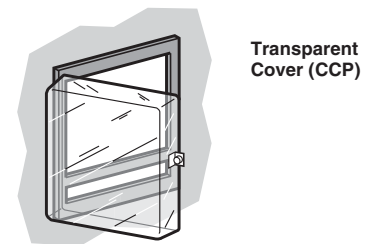

# Masterpact™ NT and NW Universal Power Circuit Breakers Accessories

## Masterpact NW Remote Racking Device

The remote racking device allows the operator to perform circuit breaker racking operations from a distance of up to 30 feet (9.1 m) away from the circuit breaker using the controller. This distance exceeds the arc flash boundary described in the arc flash safety guidelines outlined in NFPA-70E.

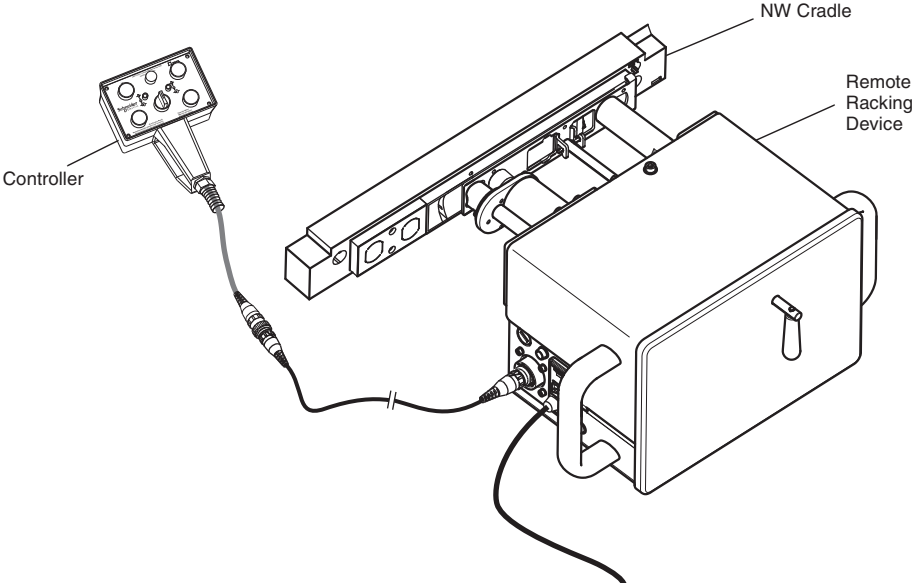

## Section 5—Wiring Diagrams

Wiring Diagrams for Masterpact NW Circuit Breakers .....	96
Wiring Diagrams for Masterpact NT Circuit Breakers .....	98
Additional Wiring Information for Masterpact NW/NT Circuit Breakers .....	100

# Masterpact™ NT and NW Universal Power Circuit Breakers Wiring Diagrams

## Wiring Diagrams for Masterpact NW Circuit Breakers

Figure 20: Wiring Diagrams for Masterpact NW Circuit Breakers

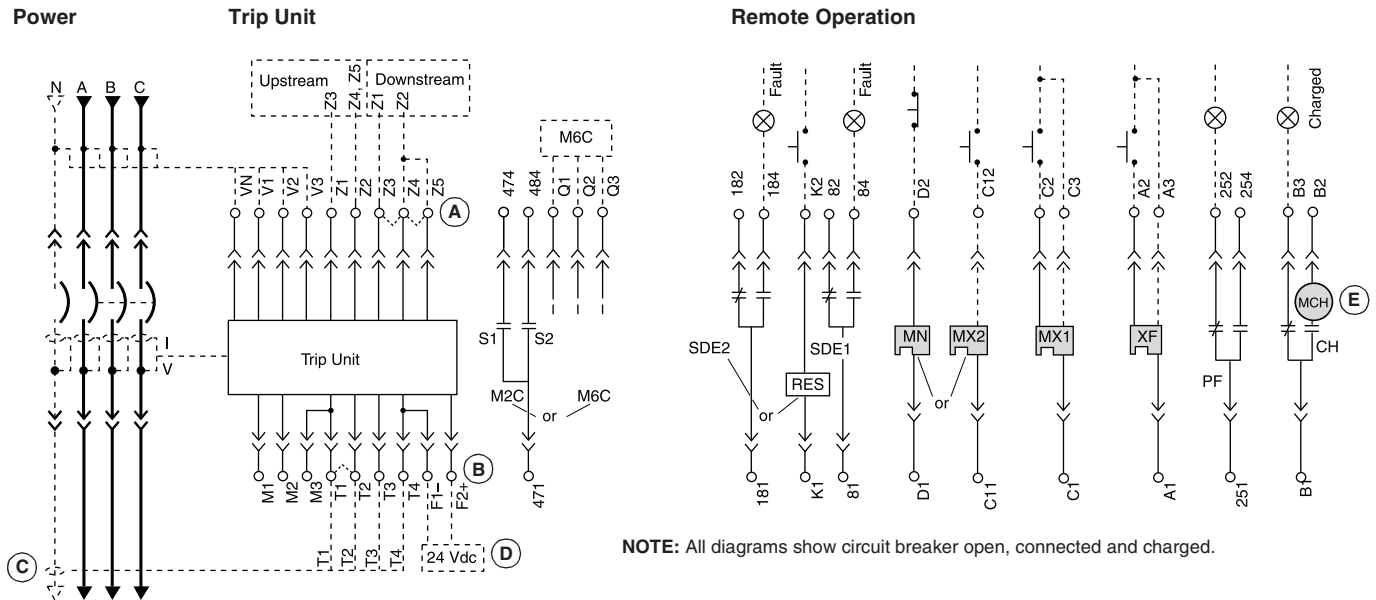

- A—Do not remove factory-installed jumpers between Z3, Z4 and Z5 unless ZSI is connected.
- B—Do not remove factory-installed jumper between T1 and T2 unless neutral CT is connected. Do not install jumper between T3 and T4.
- C—For proper wiring of neutral CT, refer to Instruction Bulletin 48041-082-01 shipped with it.
- D—24 Vdc power supply for trip unit must be separate and isolated from 24 Vdc power supply for communication modules.
- E—When remote operation features are used, make sure there is a minimum of four seconds for the spring charging motor (MCH) to completely charge the circuit breaker closing springs prior to actuating the shunt close (XF) device.

Table 61: Markings for Push-In Type Terminals

Cell Switches			Trip Unit							Cell Switches			Remote Operation								
CD3	CD2	CD1	COM	UC1	UC2	UC3	UC4	M2C/M6C	SDE2/RES	SDE1	CE3	CE2	CE1	MN/MX2	MX1	XF	PF	MCH			
834	824	814	E5	E6	Z5	M1	M2	M3	F2+	V3	484/Q3	184/K2	84	334	324	314	D2/C12	C2	A2	254	B2
832	822	812	E3	E4	Z3	Z4	T3	T4	VN	V2	474/Q2	182	82	332	322	312	C13	C3	A3	252	B3
831	821	811	E1	E2	Z1	Z2	T1	T2	F1-	V1	471/Q1	181/K1	81	331	321	311	D1/C11	C1	A1	251	B1

or

CE6	CE5	CE4
364	354	344
362	352	342
361	351	341

Table 62: Markings for Ring Terminals

Cell Switches			Trip Unit										Remote Operation							
CD3	CD2	CD1	COM	UC1	UC2	UC3	UC3a	M2C/M6C	SDE2/RES	SDE2a	SDE1	SDE1a	MN/MX2	MX1	MX1a	XF	XFa			
834/832	824/822	814/812	E5	E6	Z5	M1	M2	M3	F2+	VN	484/Q3	184/K2	182	84	82	D2/C12	C2	C3	A2	A3
831	821	811	E3	E4	Z3	Z4	T3	T4	F1-		471/Q1	181/K1		81		D1/C11	C1		A1	

# Masterpact™ NT and NW Universal Power Circuit Breakers Wiring Diagrams

## Auxiliary Contacts

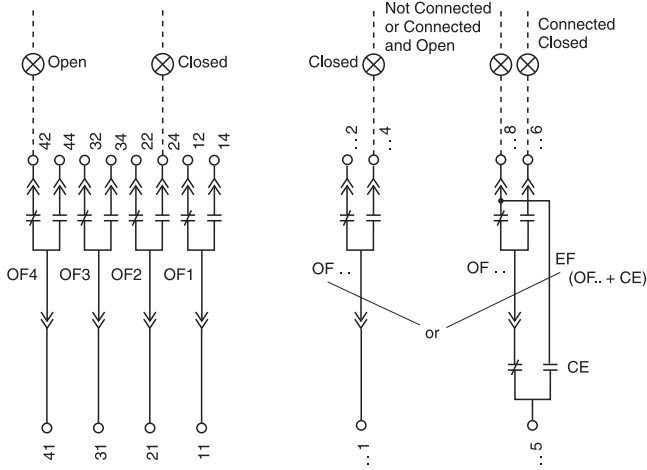

## Cell Switches

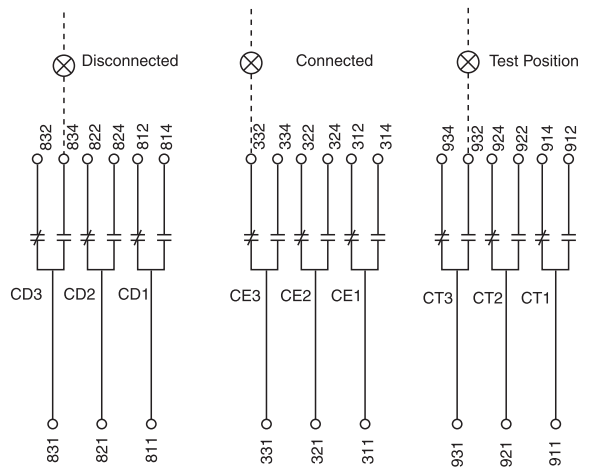

**Table 63: Markings for Push-In Type Terminals**

Auxiliary Contacts												Cell Switches <sup>1</sup>								
OF24	OF23	OF22	OF21	OF14	OF13	OF12	OF11	OF4	OF3	OF2	OF1	CT3	CT2	CT1	CD6	CD5	CD4	CE9	CE8	C7
244	234	224	214	144	134	124	114	44	34	24	14	934	924	914	864	854	844	394	384	374
242	232	222	212	142	132	122	112	42	32	22	12	932	922	912	862	852	842	392	382	372
241	231	221	211	141	131	121	111	41	31	21	11	931	921	911	861	851	841	391	381	371
or				or				or			or			or						
EF24	EF23	EF22	EF21	EF14	EF13	EF12	EF11	CD6	CD5	CD4	CE9	CE8	C7							
248	238	228	218	148	138	128	118	864	854	844	394	384	374							
246	236	226	216	146	136	126	116	862	852	842	392	382	372							
245	235	225	215	145	135	125	115	861	851	841	391	381	371							

<sup>1</sup> Fixed-mounted circuit breaker does not have cell switches (CE, CD, CT).

**Table 64: Markings for Ring Terminals**

Alarm Switches				Auxiliary Contacts								Cell Switches <sup>1</sup>		
PF	CT1	MCH	MCHa	OF14	OF13	OF12	OF11	OF4	OF3	OF2	OF1	CE3	CE2	CE1
252	914/912	B2	B3	144	134	122	112	44	34	22	12	334/332	324/322	314/312
251	911	B1		141	131	121	111	41	31	21	11	331	321	311

<sup>1</sup> Fixed-mounted circuit breaker does not have cell switches (CE, CD, CT).

# Masterpact™ NT and NW Universal Power Circuit Breakers Wiring Diagrams

## Wiring Diagrams for Masterpact NT Circuit Breakers

Figure 21: Markings for Push-In Type Terminals

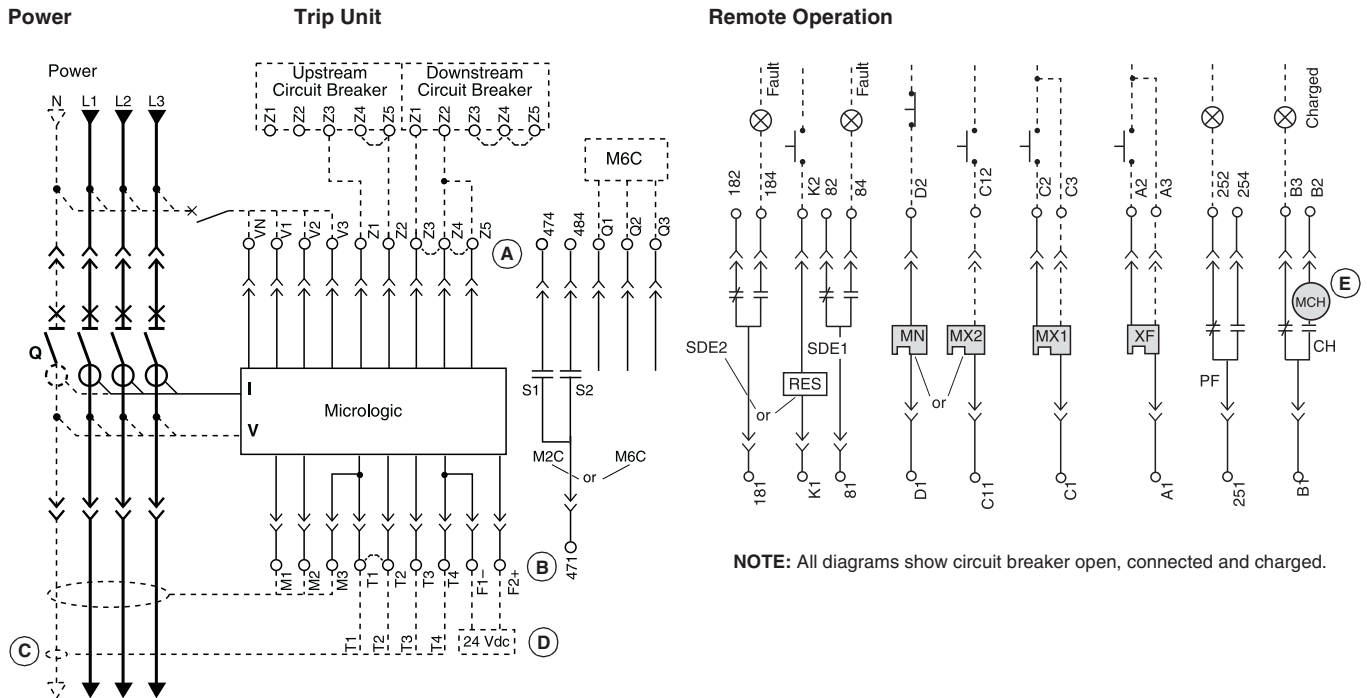

- A—Do not remove factory-installed jumpers between Z3, Z4 and Z5 unless ZS1 is connected.
- B—Do not remove factory-installed jumper between T1 and T2 unless neutral CT is connected. Do not install jumper between T3 and T4.
- C—For proper wiring of neutral CT, refer to Instrucion Bulletin 48041-082-01 shipped with it.
- D—24 Vdc power supply for trip unit must be separate and isolated from 24 Vdc power supply for communication modules.
- E—When remote operation features are used, make sure there is a minimum of four seconds for the spring charging motor (MCH) to completely charge the circuit breaker closing springs prior to actuating the shunt close (XF) device.

Table 65: Markings for Push-In Type Terminals

Cell Switches		Trip Unit						
CD2	CD1	COM	UC1	UC2	UC3	UC4 / M2C / M6C	SDE2 / RES	SDE1
Remote Operation								
MN / MX2	MX1	XF	PF	MCH				

# Masterpact™ NT and NW Universal Power Circuit Breakers Wiring Diagrams

## Auxiliary Switches

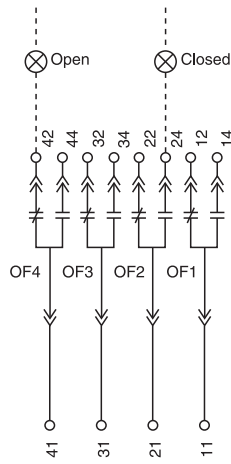

## Cell Switches

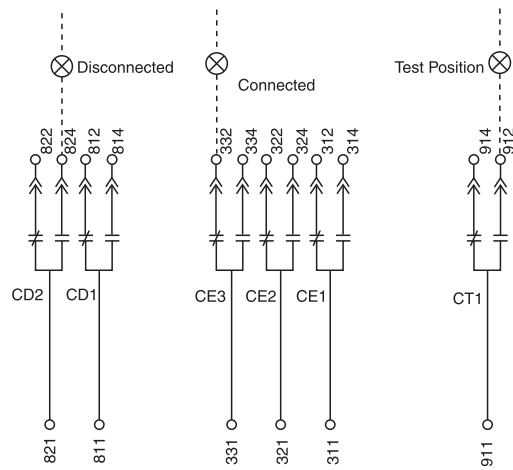

**Table 66: Markings for Push-In Type Terminals**

Auxiliary Switches				Cell Switches			
OF4	OF3	OF2	OF1	CE3	CE2	CE1	CT1

**Figure 22: Spring-Charging Motor**

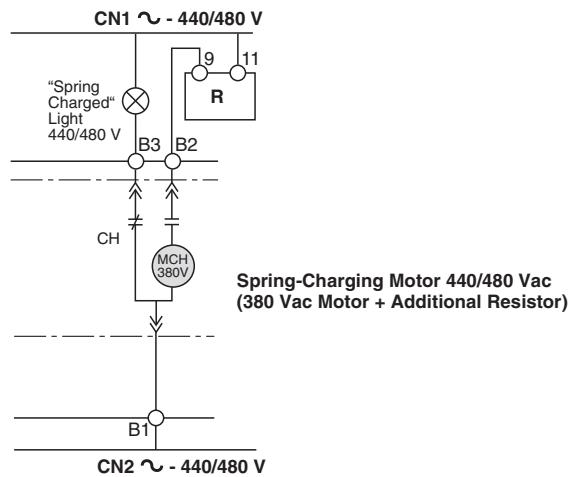

# Masterpact™ NT and NW Universal Power Circuit Breakers

## Wiring Diagrams

### Additional Wiring Information for Masterpact NW/NT Circuit Breakers

Alarm Contacts (OF1, OF2, OF3 and OF4 are standard equipment)		Cradle Contacts	
OF4	Open/Closed Circuit Breaker or Switch Position Contacts	OF24:	Open/Closed Circuit Breaker or Switch Position Contact
OF3	Open/Closed Circuit Breaker or Switch Position Contacts	or	
OF2		EF24:	Combined Connected and Closed Contact
OF1			
		OF23 or EF23	
		OF22 or EF22	
		OF21 or EF21	
		OF14 or EF14	
		OF13 or EF13	
		OF12 or EF12	
		OF22 or EF22	
		OF11 or EF11	
		CE6	Connected
		CE5	Position Contacts
		CE4	
		CE9	Connected
		CE8	Position
		CE7	Contacts
			or
			CD6
			Disconnected
			CD5
			Position
			CD4
			Contacts

Trip Unit			
Basic	A	P	H
	X	X	X
Com: E1–E6 Communication			
	X	X	X
Z1–Z5 Logical Selectivity			
	X	X	X
Z1 = ZSI OUT			
	X	X	X
UC1: Z2 = ZSI OUT Source; Z3 = ZSI IN Source			
	X	X	X
Z4 = ZSI IN Short-Time Delay			
	X	X	X
Z5 = ZSI IN Ground Fault			
	X	X	X
UC3: F2+, F1– 24 Vdc External Power Supply			
	X	X	X
External Neutral VN Plug			
	X	X	X
UC4: External Phase Voltage Sensing			
	X	X	X
M2C Two Programmable Contacts (internal relay)			
	X	X	X
or			
M6C Six Programmable Contacts (for connection to external M6C module)			

Remote Operation	
SDE2 or RES	Electrical Fault Alarm Contact Remote Reset
SDE1	Electrical Fault Alarm Contact (standard)
MN or MX2	Undervoltage Trip Device Additional Shunt Trip
MX1	Shunt Trip (standard or networked)
XF	Shunt Close (standard or networked)
PF	Ready-to-Close Contact
MCH	Spring-Charging Motor

**NOTE:** When communication version of the MX1 or XF coils are used, terminals (C3, A3) must be connected to line even if the communications module is not installed. The bypass circuit through terminal C2/A2 is only momentary duty for 0.5 sec. For continuous duty, use the communications command.

Figure 23: Connection of the Communications Option

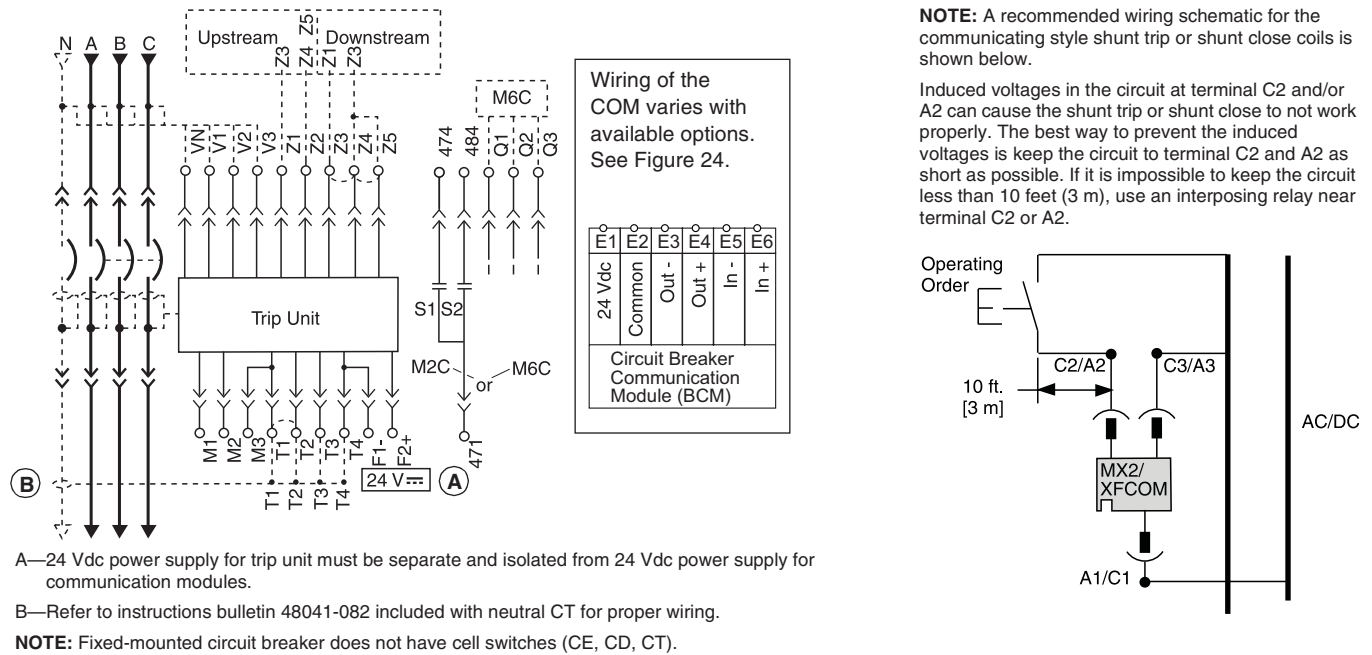

A—24 Vdc power supply for trip unit must be separate and isolated from 24 Vdc power supply for communication modules.

B—Refer to instructions bulletin 48041-082 included with neutral CT for proper wiring.

**NOTE:** Fixed-mounted circuit breaker does not have cell switches (CE, CD, CT).



# Masterpact™ NT and NW Universal Power Circuit Breakers Wiring Diagrams

Figure 24: Wiring Diagrams for the COM Option

Wiring of the I/O Modules

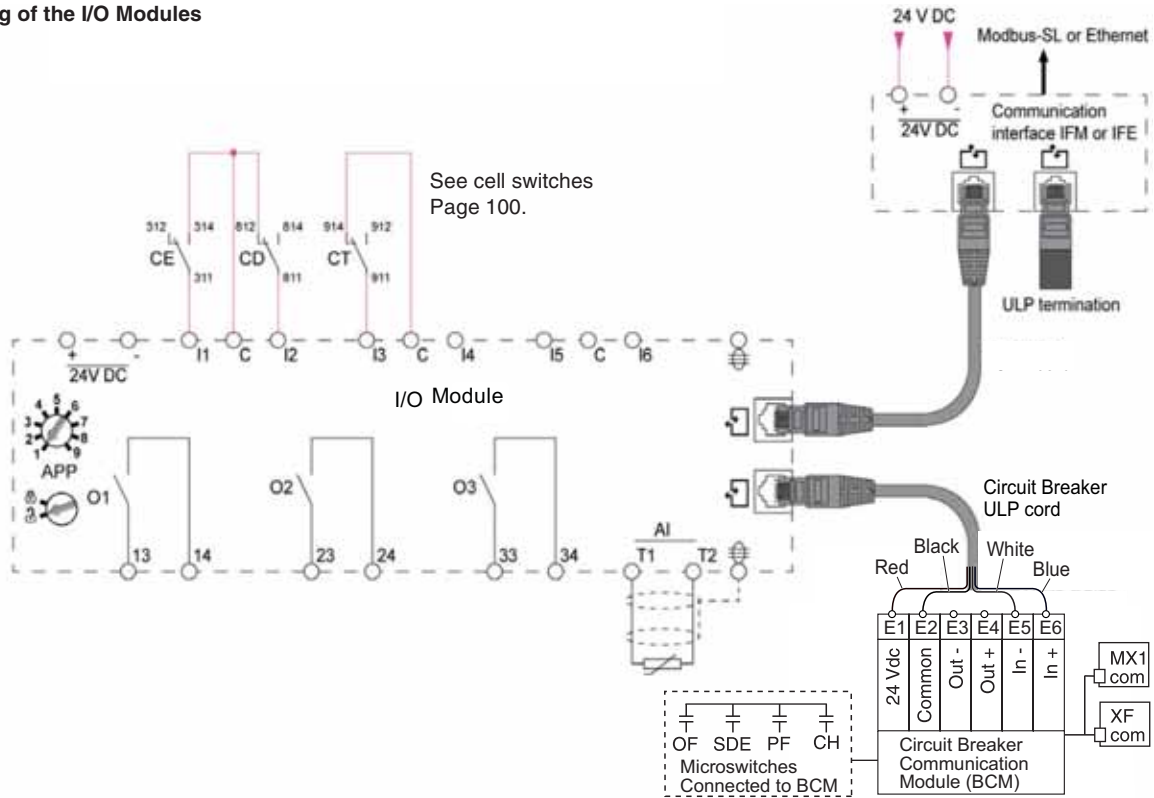

Wiring of the COM Option (Modbus BCM ULP and CCM Modules)

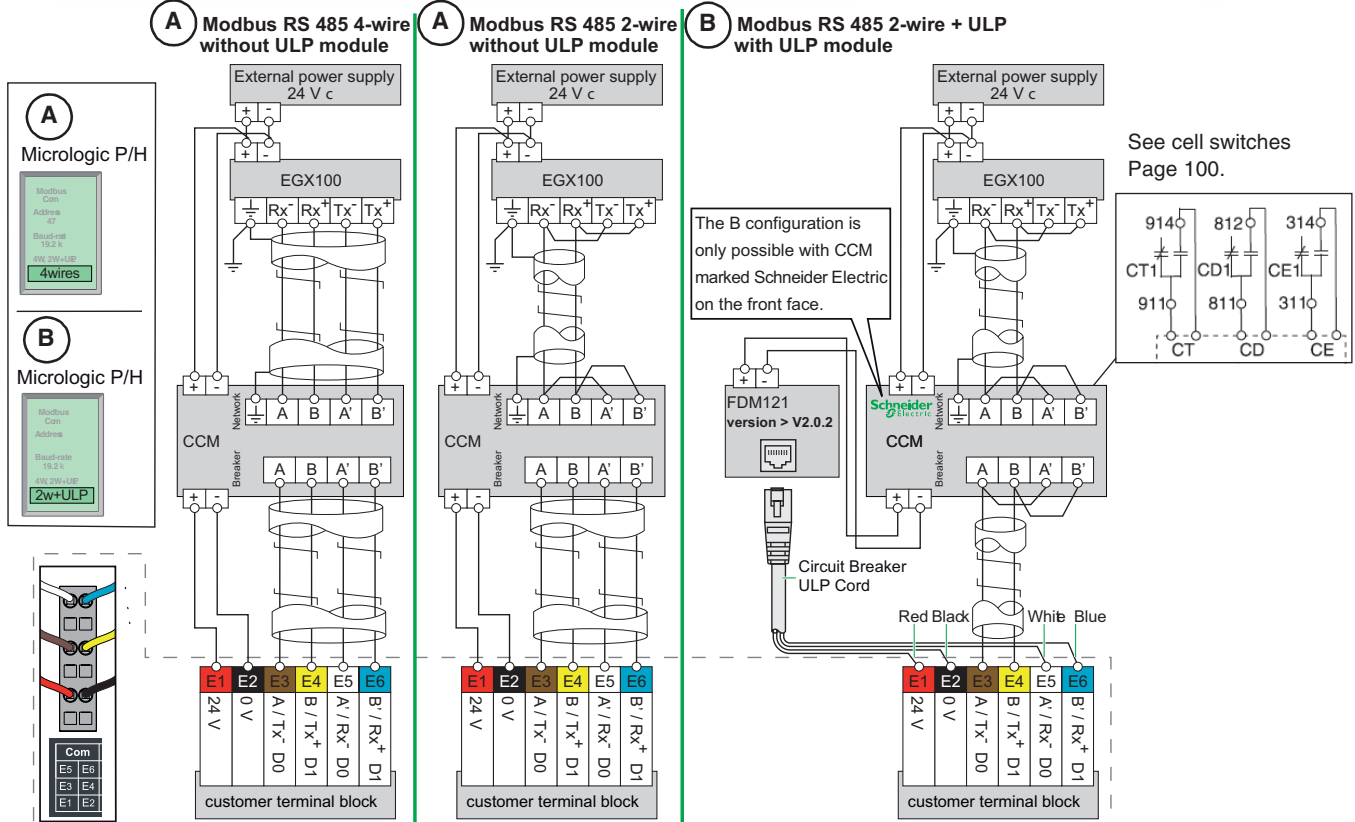

Section 6—Masterpact NT Dimensional Drawings

Masterpact NT Enclosure Information ..... 104

UL Listed and ANSI Certified Three-Pole Drawout Circuit Breakers ..... 104

    800–1200 A Masterpact NT Three-Pole Drawout—Master Drawing ..... 105

    800–1200 A Masterpact NT UL/ANSI Three-Pole Drawout—RCTH Rear Connected “T” Horizontal 106

    800–1200 A Masterpact NT UL/ANSI Three-Pole Drawout—RCTV Rear Connected “T” Vertical .... 107

    800–1200 A Masterpact NT UL/ANSI Three-Pole Drawout—FCF Front Connected Flat ..... 108

    800–1200 A Masterpact NT UL/ANSI Three-Pole Drawout—Door Cutout Dimensions ..... 108

    800–1200 A Masterpact NT UL/ANSI Three-Pole Drawout—Pan Dimensions ..... 108

UL Listed and ANSI Certified Three-Pole Fixed Circuit Breakers ..... 109

    800–1200 A and 1600 A Masterpact NT UL/ANSI Three-Pole Fixed—Master Drawing ..... 109

    800–1200 A Masterpact NT UL/ANSI Three-Pole Fixed—RCTH Rear Connected “T” Horizontal ..... 110

    800–1200 A Masterpact NT UL/ANSI Three-Pole Fixed—RCTV Rear Connected “T” Vertical .. 111

    800–1200 A Masterpact NT UL/ANSI Three-Pole Fixed—FCF Front Connected Flat ..... 112

    1600 A Masterpact NT UL/ANSI Three-Pole Fixed—RCV Rear Connected Fixed Vertical..... 113

    800–1200 A Masterpact NT UL/ANSI Three-Pole Fixed—Door Cutout Dimensions ..... 113

    800–1200 A Masterpact NT UL/ANSI Three-Pole Fixed—Pan Dimensions ..... 114

UL Listed and ANSI Certified Four-Pole Drawout Circuit Breakers ..... 115

    800–1200 A Masterpact NT UL/ANSI Four-Pole Drawout—Master Drawing ..... 115

    800–1200 A Masterpact NT UL/ANSI Four-Pole Drawout—RCTH Rear Connected “T” Horizontal .. 116

    800–1200 A Masterpact NT UL/ANSI Four-Pole Drawout—RCTV Rear Connected “T” Vertical 117

    800–1200 A Masterpact NT UL/ANSI Four-Pole Drawout—FCF Front Connected Flat ..... 118

    800–1200 A Masterpact NT UL/ANSI Four-Pole Drawout—Door Cutout Dimensions ..... 118

    800–1200 A Masterpact NT UL/ANSI Four-Pole Drawout—Pan Dimensions ..... 119

UL Listed and ANSI Certified Four-Pole Fixed Circuit Breakers ..... 120

    800–1200 A Masterpact NT UL/ANSI Four-Pole Fixed—Master Drawing ..... 120

    800–1200 A Masterpact NT UL/ANSI Four-Pole Fixed—RCTH Rear Connected “T” Horizontal 121

    800–1200 A Masterpact NT UL/ANSI Four-Pole Fixed—RCTV Rear Connected “T” Vertical .... 122

    800–1200 A Masterpact NT UL/ANSI Four-Pole Fixed—FCF Front Connected Flat ..... 123

    800–1200 A Masterpact NT UL/ANSI Four-Pole Fixed—Door Cutout Dimensions ..... 124

    800–1200 A Masterpact NT UL/ANSI Four-Pole Fixed—Pan Dimensions ..... 124

IEC Rated Three-Pole Drawout Circuit Breakers..... 125

    800–1600 A Masterpact NT Three-Pole Drawout—Master Drawing ..... 125

    800–1600 A Masterpact NT IEC Three-Pole Drawout—RCTV Rear Connected “T” Vertical .... 126

    800–1600 A Masterpact NT IEC Three-Pole Drawout—RCTH Rear Connected “T” Horizontal . 127

    800–1600 A Masterpact NT IEC Three-Pole Drawout—FCF Front Connected Flat ..... 128

    800–1200 A Masterpact NT IEC Three-Pole Drawout—Rear Cutout Dimensions ..... 128

IEC Rated Three-Pole Fixed Circuit Breakers ..... 129

    800–1600 A Masterpact NT Three-Pole Fixed—Master Drawing ..... 129

    800–1600 A Masterpact NT IEC Three-Pole Fixed—RCTV Rear Connected “T” Vertical ..... 130

    800–1600 A Masterpact NT IEC Three-Pole Fixed—RCTH Rear Connected “T” Horizontal .... 131

    800–1600 A Masterpact NT IEC Three-Pole Fixed—FCF Front Connected Flat ..... 132

    800–1200 A Masterpact NT IEC Three-Pole Fixed—Rear Cutout Dimensions ..... 133

IEC Rated Four-Pole Drawout Circuit Breakers ..... 134

    800–1600 A Masterpact NT Four-Pole Drawout—Master Drawing ..... 134

    800–1600 A Masterpact NT IEC Four-Pole Drawout—RCTV Rear Connected “T” Vertical ..... 135

    800–1600 A Masterpact NT IEC Four-Pole Drawout—RCTH Rear Connected “T” Horizontal ... 136

    800–1600 A Masterpact NT IEC Four-Pole Drawout—FCF Front Connected Flat ..... 137

    800–1200 A Masterpact NT IEC Four-Pole Drawout—Rear Cutout Dimensions ..... 137

IEC Rated Four-Pole Fixed Circuit Breakers ..... 138

    800–1600 A Masterpact NT Four-Pole Fixed—Master Drawing ..... 138

    800–1600 A Masterpact NT IEC Four-Pole Fixed—RCTV Rear Connected “T” Vertical ..... 139

    800–1600 A Masterpact NT IEC Four-Pole Fixed—RCTH Rear Connected “T” Horizontal ..... 140

    800–1600 A Masterpact NT IEC Four-Pole Fixed—FCF Front Connected Flat ..... 141

    800–1200 A Masterpact NT IEC Four-Pole Fixed—Rear Cutout Dimensions ..... 141

# Masterpact™ NT and NW Universal Power Circuit Breakers

## Masterpact NT Dimensional Drawings

Neutral Current Transformers for Masterpact NT Circuit Breakers .....	142
800–1200 A External Neutral Current Transformer .....	142
800–1200 A External Neutral Current Transformer (Switchboards and Switchgear .....	143
800–1200 A External Neutral Current Transformer (Panelboards) .....	143

# Masterpact™ NT and NW Universal Power Circuit Breakers

## Masterpact NT Dimensional Drawings

### Masterpact NT Enclosure Information

Table 67: Minimum Enclosure Information

Number of Poles	Circuit Breaker Rating	Circuit Breaker Enclosure Dimensions		Ventilation Area			
		(H x W x D)		Top		Bottom	
		in.	mm	in. <sup>2</sup>	mm <sup>2</sup>	in. <sup>2</sup>	mm <sup>2</sup>
3	800 to 1600 A (N, H, L1)	18.25 x 13 x 9.5	463.5 x 330.2 x 241.3	9	5806	9	5806
	800 to 1600 A (L)	62.25 x 23 x 14.75	1581.2 x 584.2 x 374.7	16.5	10645	16.5	10645
4	800 to 1600 A (N, H, L1)	18.25 x 15.8 x 9.5	463.5 x 401.3 x 241.3	9	5806	9	5806
	800 to 1600 A (L)	62.25 x 25.76 x 14.75	1581.2 x 654.2 x 374.7	16.5	10645	16.5	10645

### UL®/ANSI Three-Pole Drawout Circuit Breakers

Figure 25: 800–1200 A Masterpact NT Three-Pole Drawout—Master Drawing

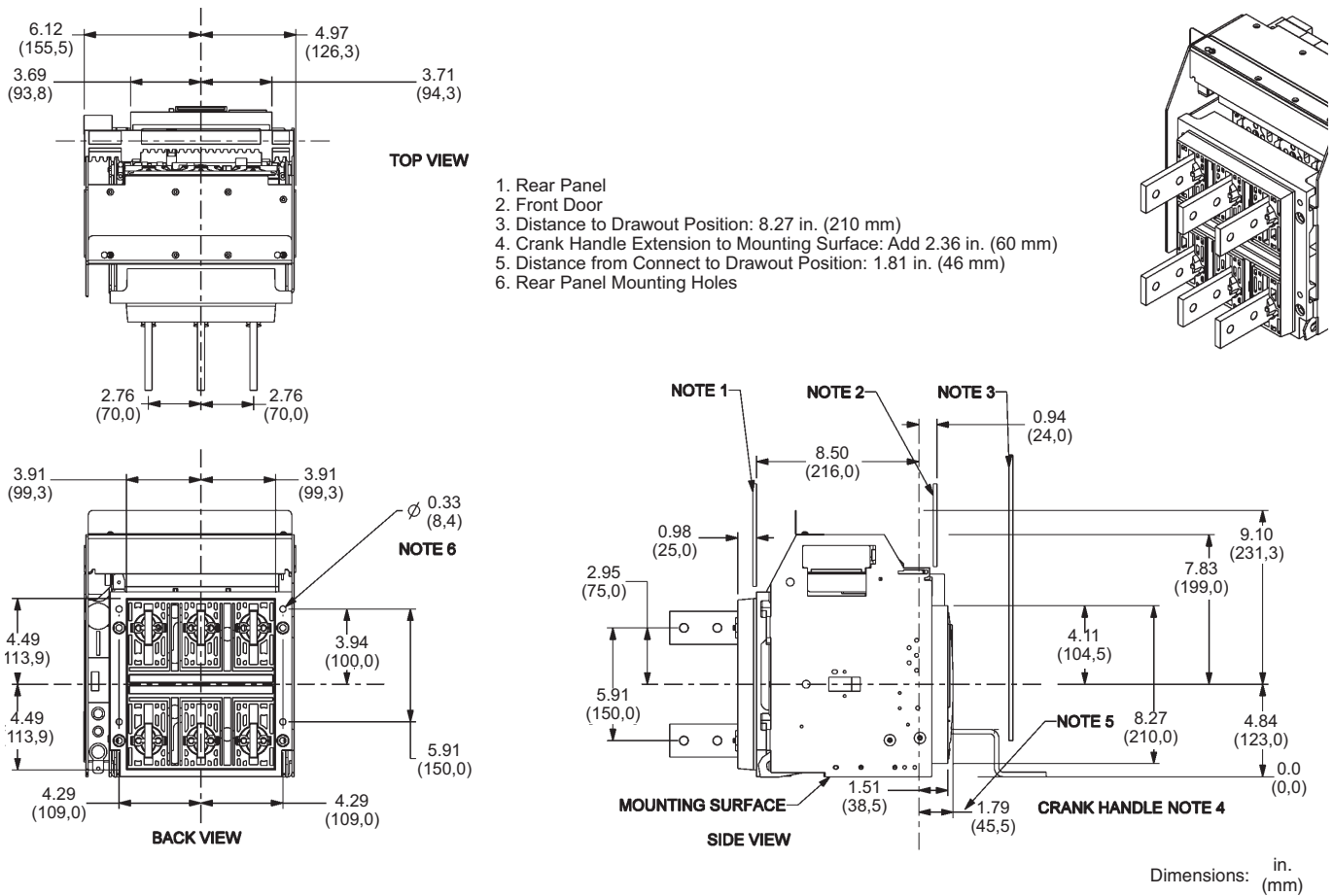

1. Rear Panel
2. Front Door
3. Distance to Drawout Position: 8.27 in. (210 mm)
4. Crank Handle Extension to Mounting Surface: Add 2.36 in. (60 mm)
5. Distance from Connect to Drawout Position: 1.81 in. (46 mm)
6. Rear Panel Mounting Holes

# Masterpact™ NT and NW Universal Power Circuit Breakers

## Masterpact NT Dimensional Drawings

**Figure 26: 800–1200 A Masterpact NT UL/ANSI Three-Pole Drawout—RCTH Rear-Connected “T” Horizontal**

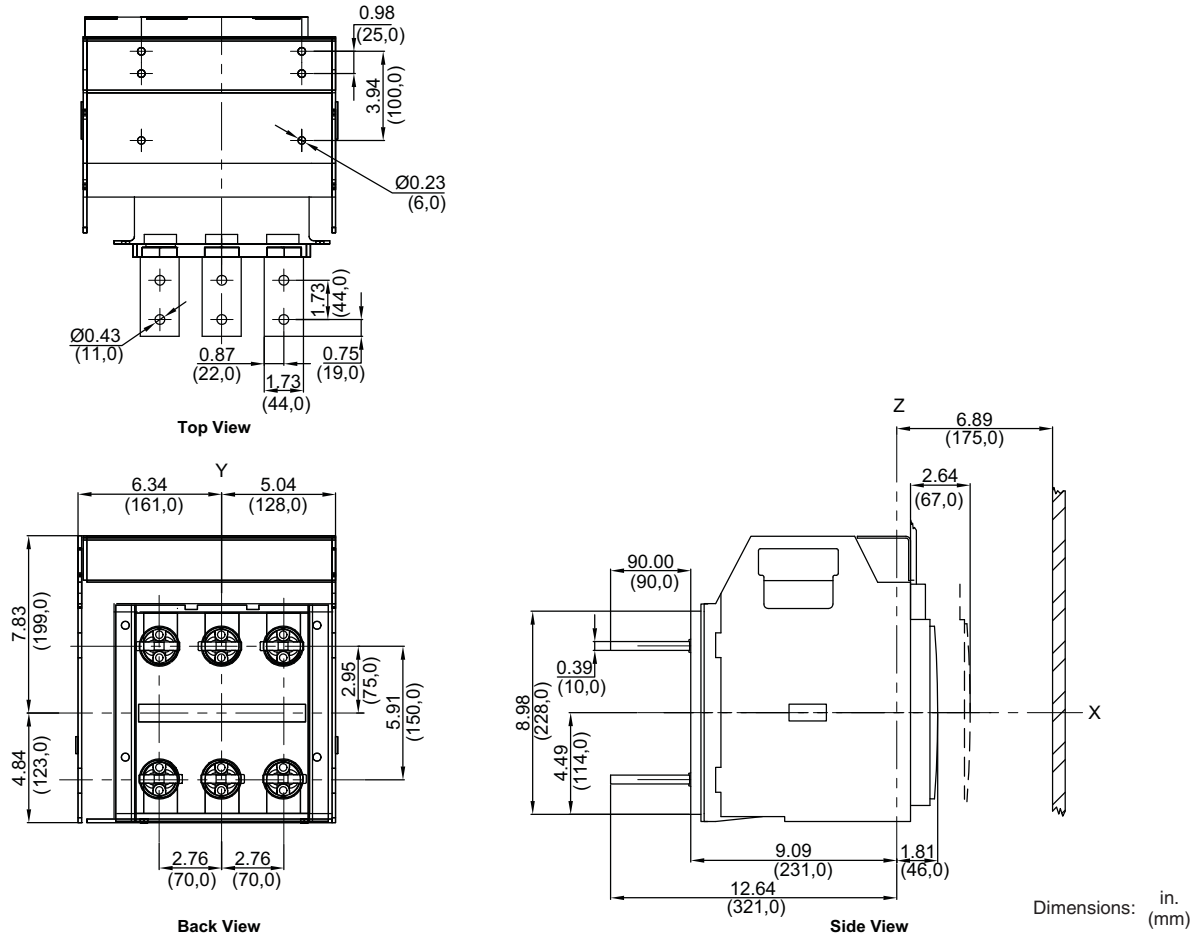

# Masterpact™ NT and NW Universal Power Circuit Breakers

## Masterpact NT Dimensional Drawings

Figure 27: 800–1200 A Masterpact NT UL/ANSI Three-Pole Drawout—RCTV Rear-Connected “T” Vertical

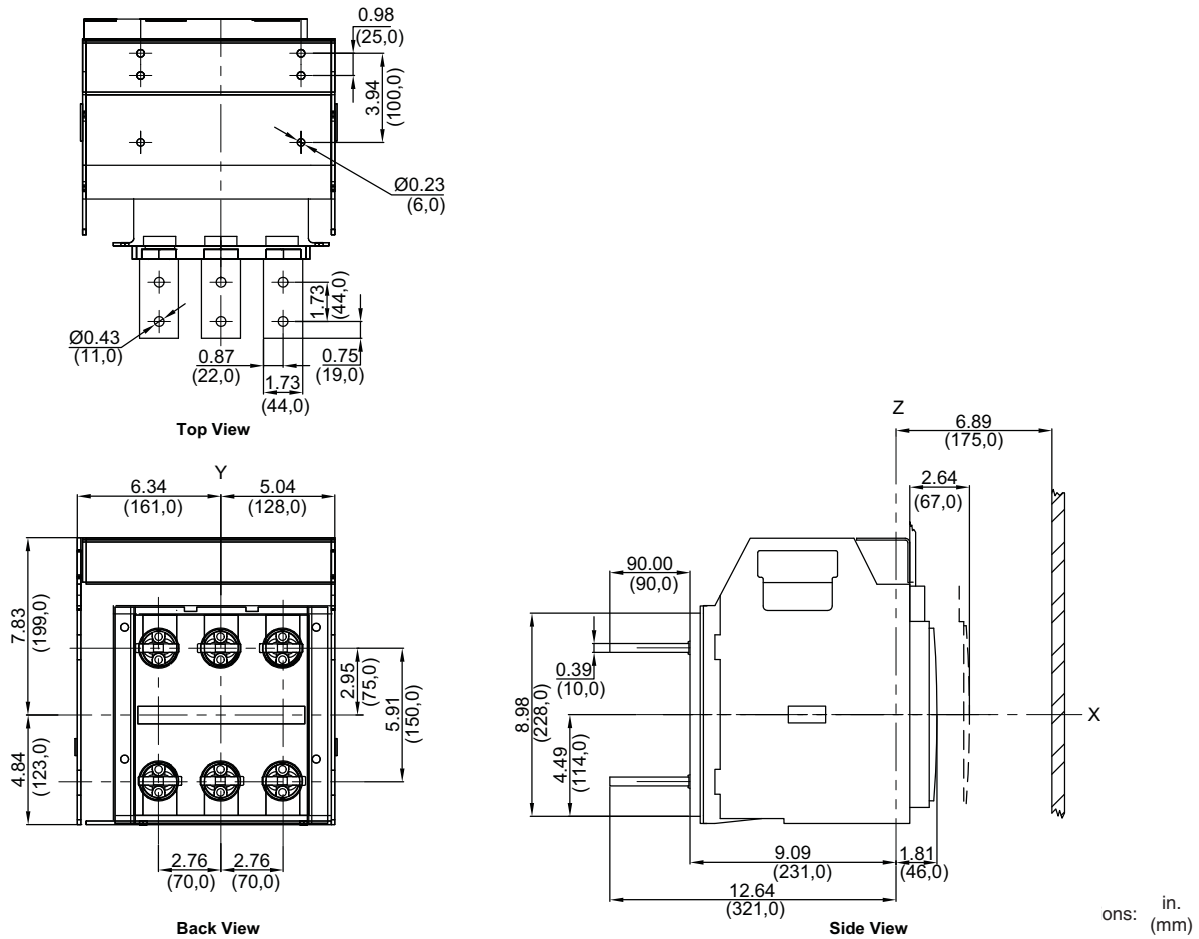

# Masterpact™ NT and NW Universal Power Circuit Breakers

## Masterpact NT Dimensional Drawings

**Figure 28: 800–1200 A Masterpact NT UL/ANSI Three-Pole Drawout—FCF Front-Connected Flat**

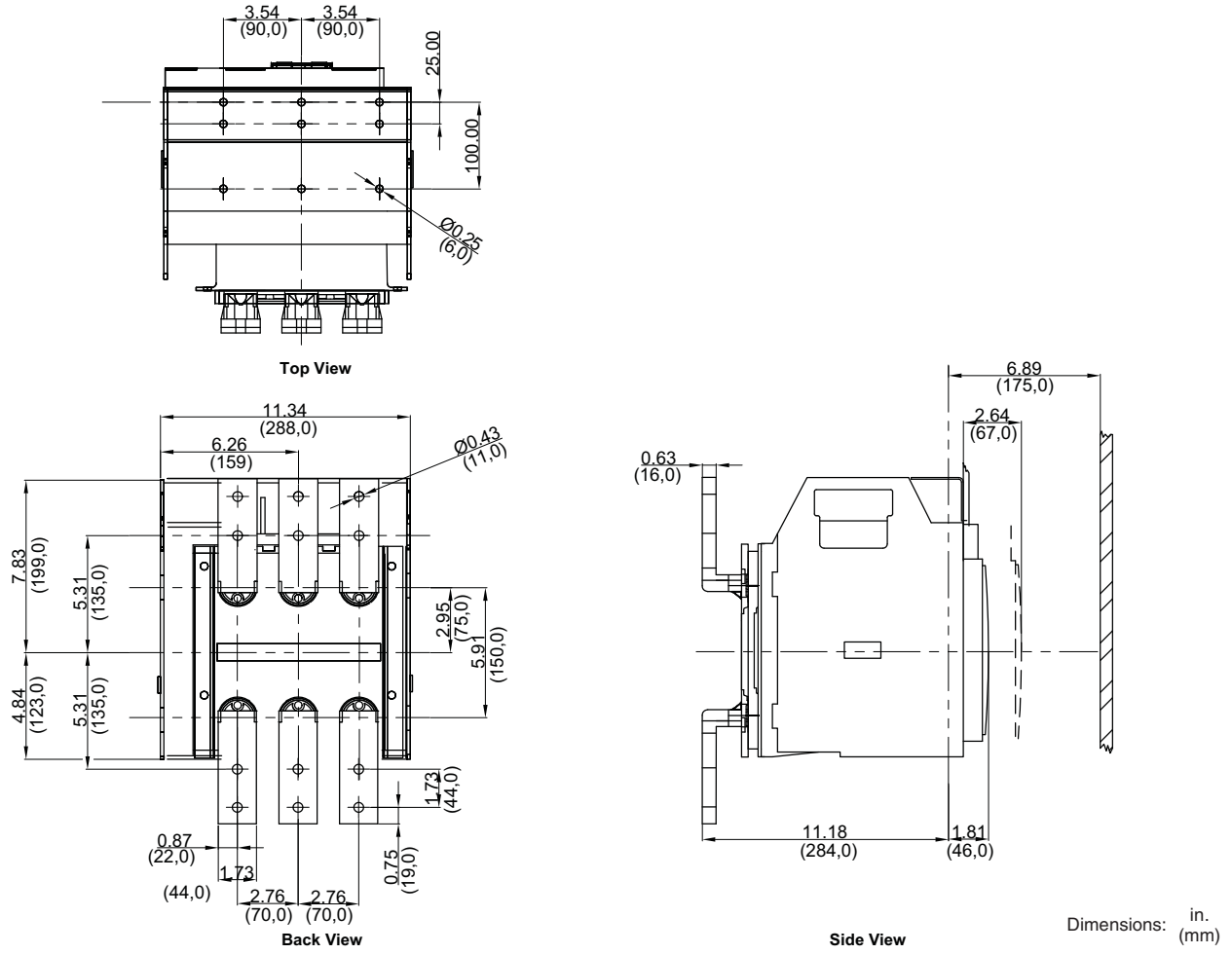

# Masterpact™ NT and NW Universal Power Circuit Breakers

## Masterpact NT Dimensional Drawings

Figure 29: 800–1200 A Masterpact NT UL/ANSI Three-Pole Drawout—Door Cutout Dimensions

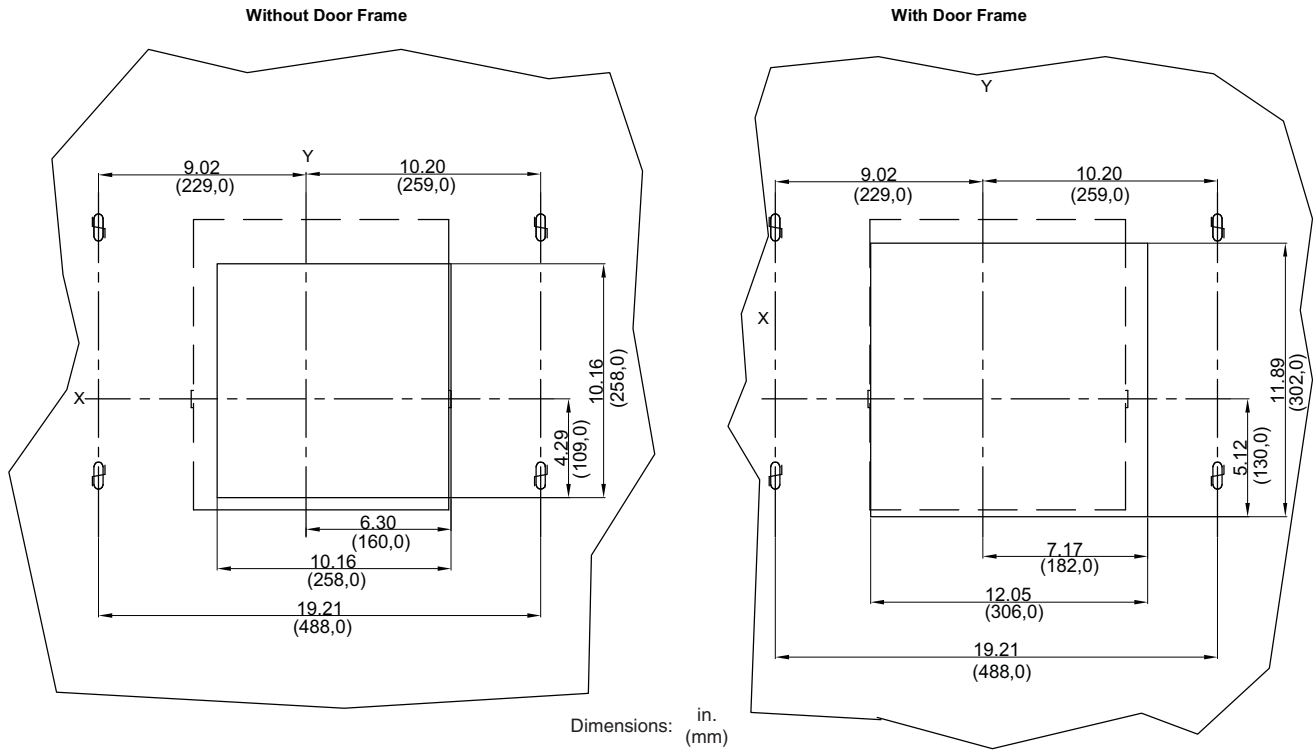
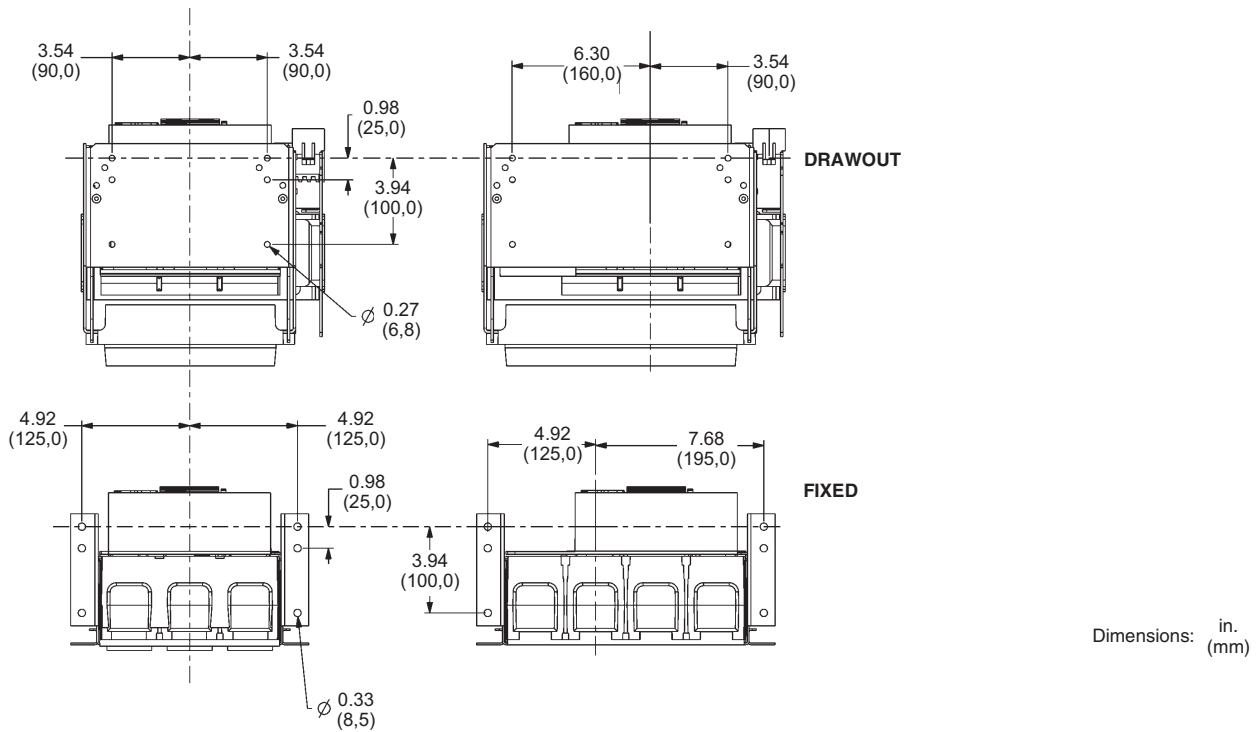

Figure 30: 800–1200 A Masterpact NT UL/ANSI Drawout and Fixed—Pan Dimensions





# Masterpact™ NT and NW Universal Power Circuit Breakers

## Masterpact NT Dimensional Drawings

### UL/ANSI Three Pole Fixed Circuit Breakers

**Figure 31: 800–1200 A and 1600 A Masterpact NT UL/ANSI Three-Pole Fixed—Master Drawing**

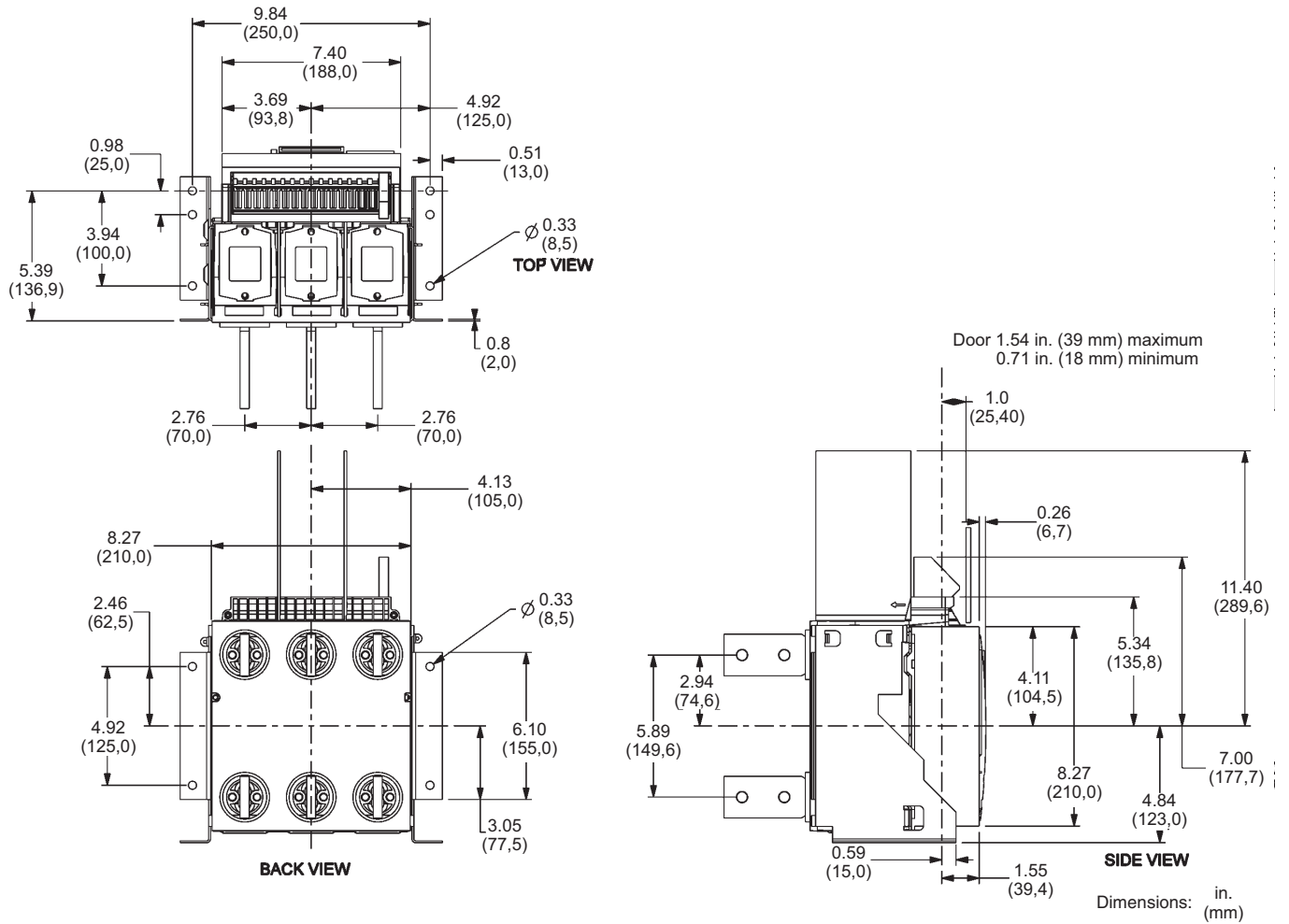

# Masterpact™ NT and NW Universal Power Circuit Breakers

## Masterpact NT Dimensional Drawings

Figure 32: 800–1200 A Masterpact NT UL/ANSI Three-Pole Fixed—RCTH Rear-Connected “T” Horizontal

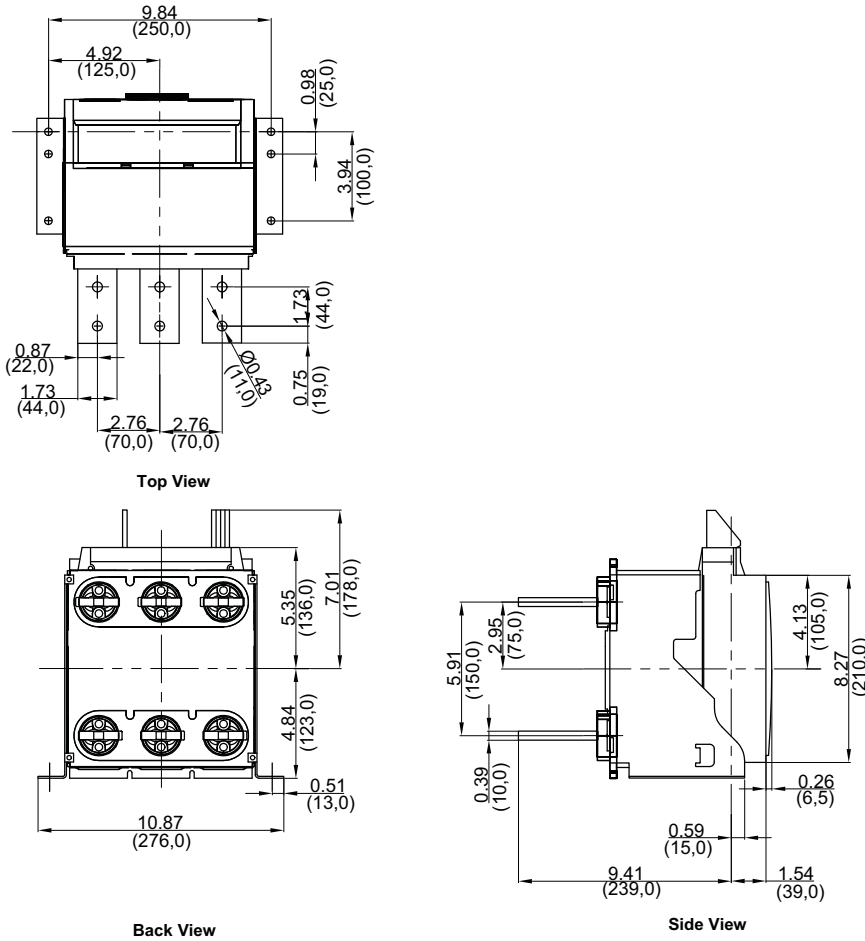

Dimensions: in.  
(mm)

# Masterpact™ NT and NW Universal Power Circuit Breakers

## Masterpact NT Dimensional Drawings

**Figure 33: 800–1200 A Masterpact NT UL/ANSI Three-Pole Fixed—RCTV Rear-Connected “T” Vertical**

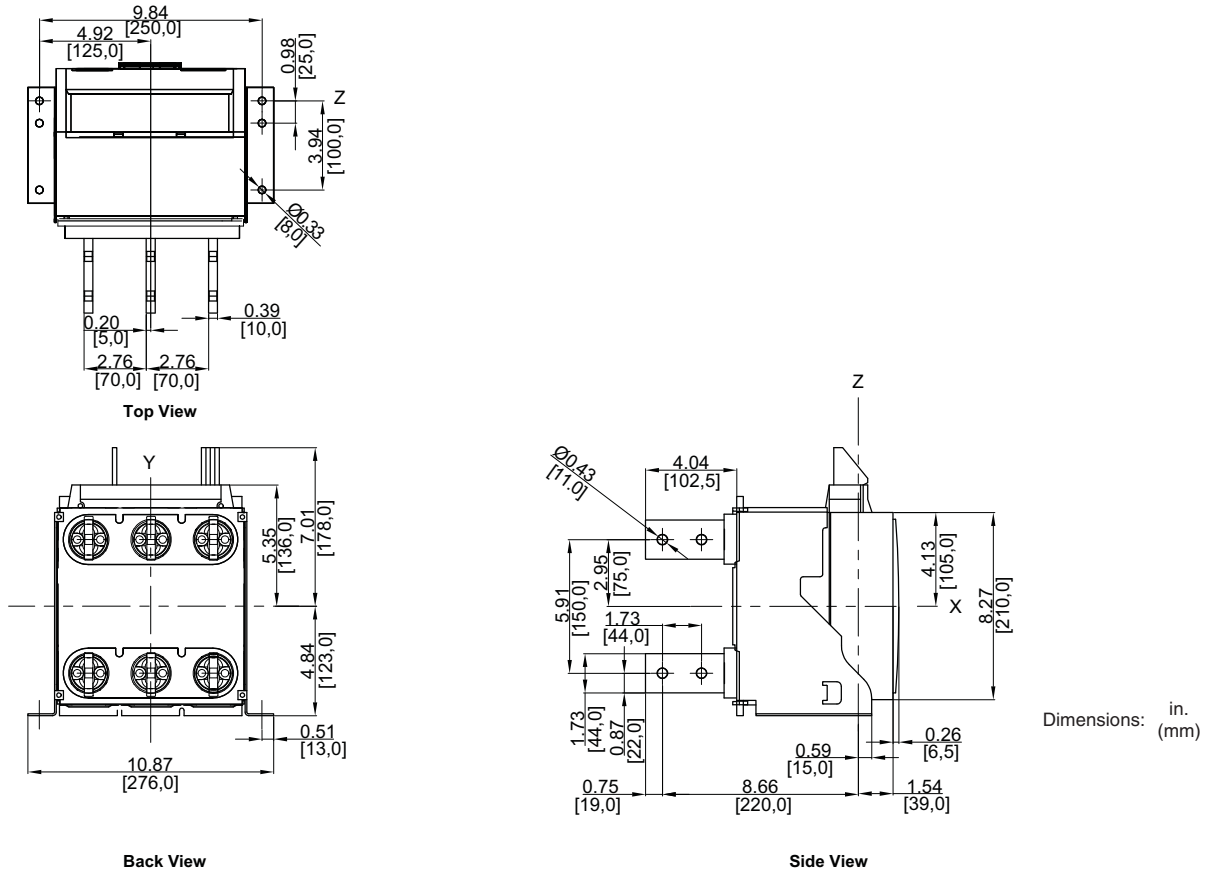

# Masterpact™ NT and NW Universal Power Circuit Breakers

## Masterpact NT Dimensional Drawings

Figure 34: 800–1200 A Masterpact NT UL/ANSI Three-Pole Fixed—FCF Front-Connected Flat

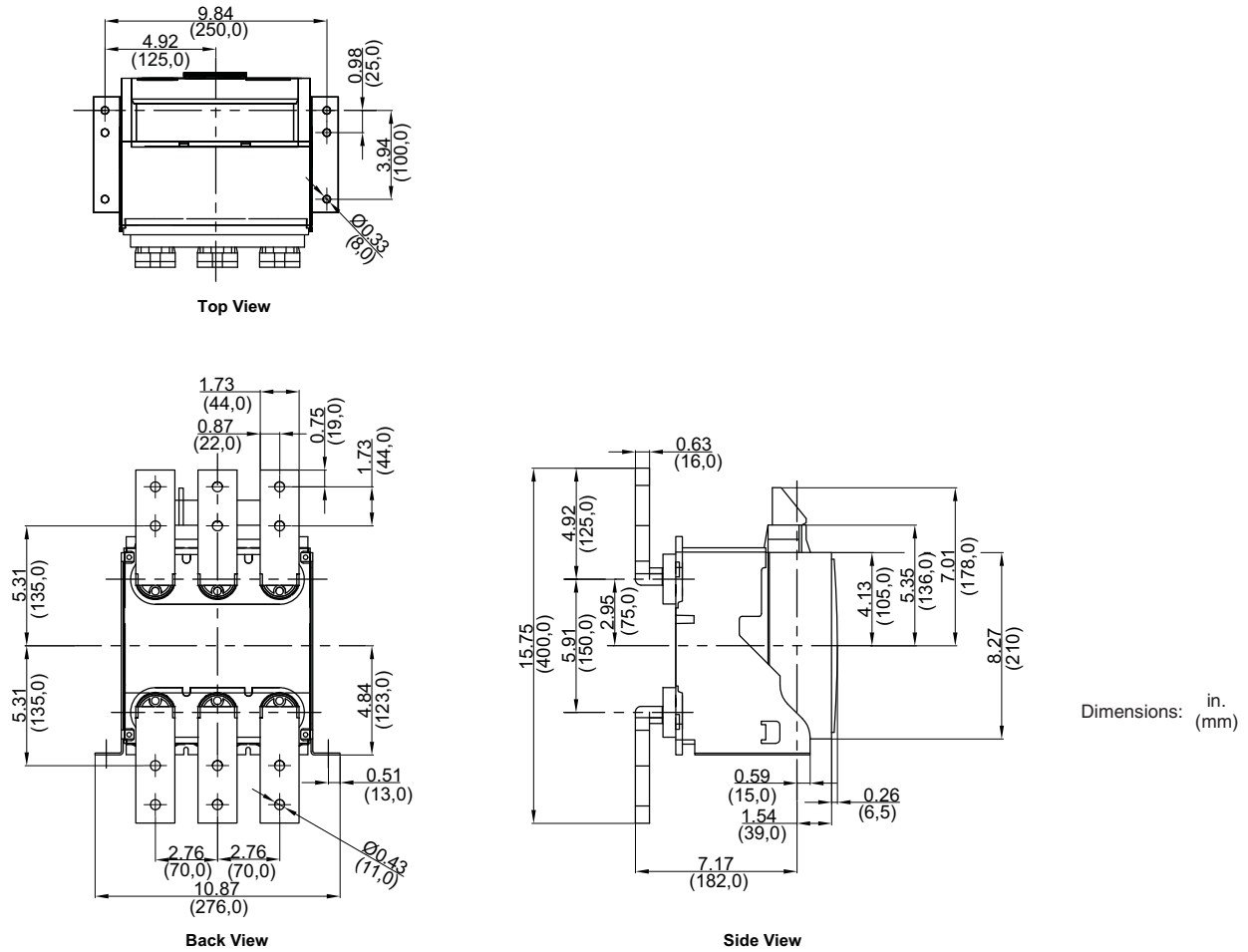

# Masterpact™ NT and NW Universal Power Circuit Breakers

## Masterpact NT Dimensional Drawings

**Figure 35: 1600 A Masterpact NT UL Three-Pole Fixed—RCV Rear-Connected Vertical**

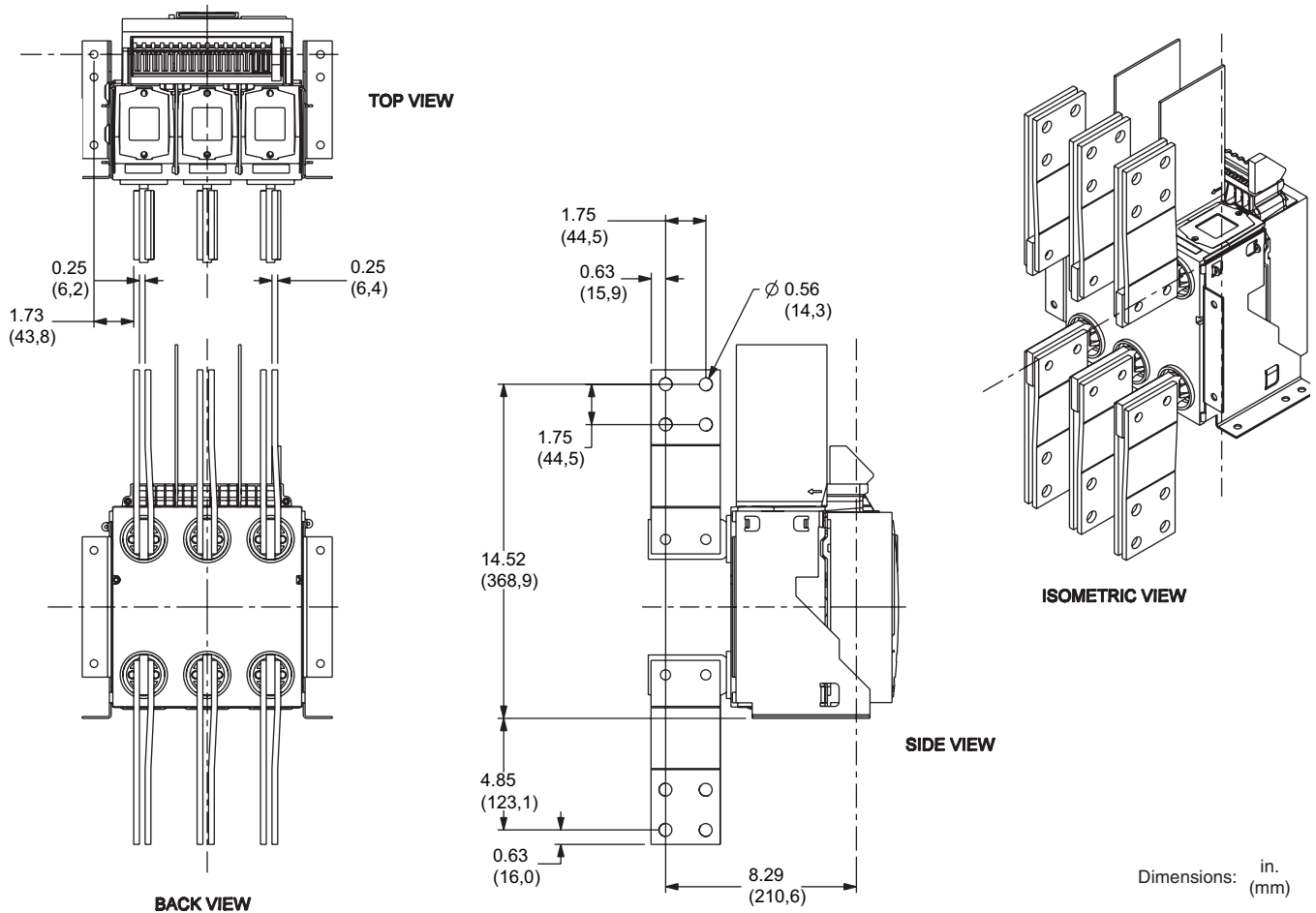

**Figure 36: 800–1200 A Masterpact NT UL/ANSI Three-Pole Fixed—Door Cutout Dimensions**

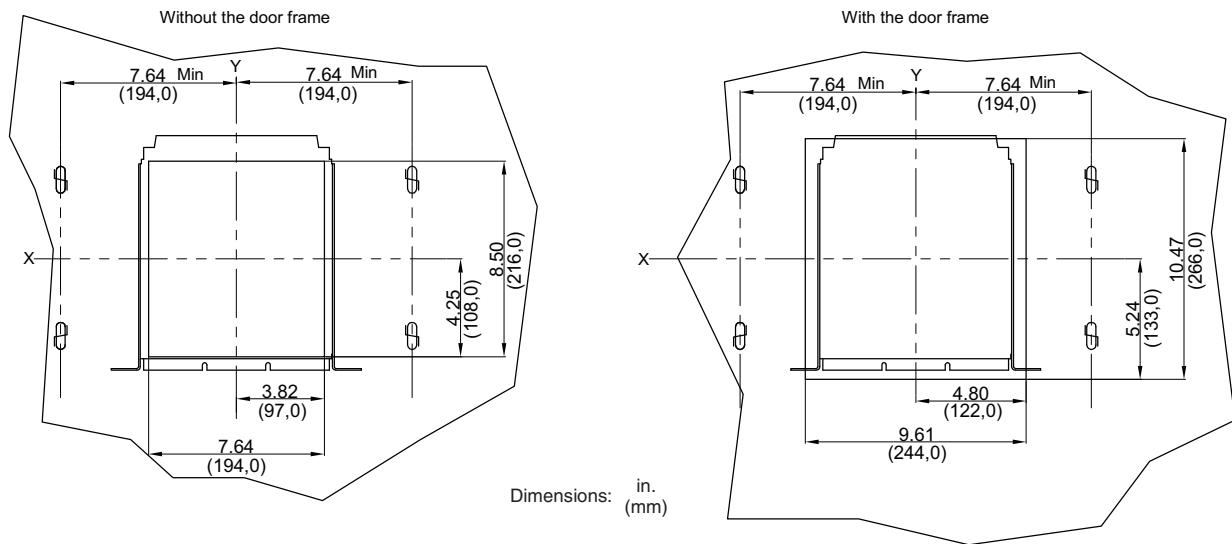

# Masterpact™ NT and NW Universal Power Circuit Breakers

## Masterpact NT Dimensional Drawings

Figure 37: 800–1200 A Masterpact NT UL/ANSI Fixed and Drawout—Pan Dimensions

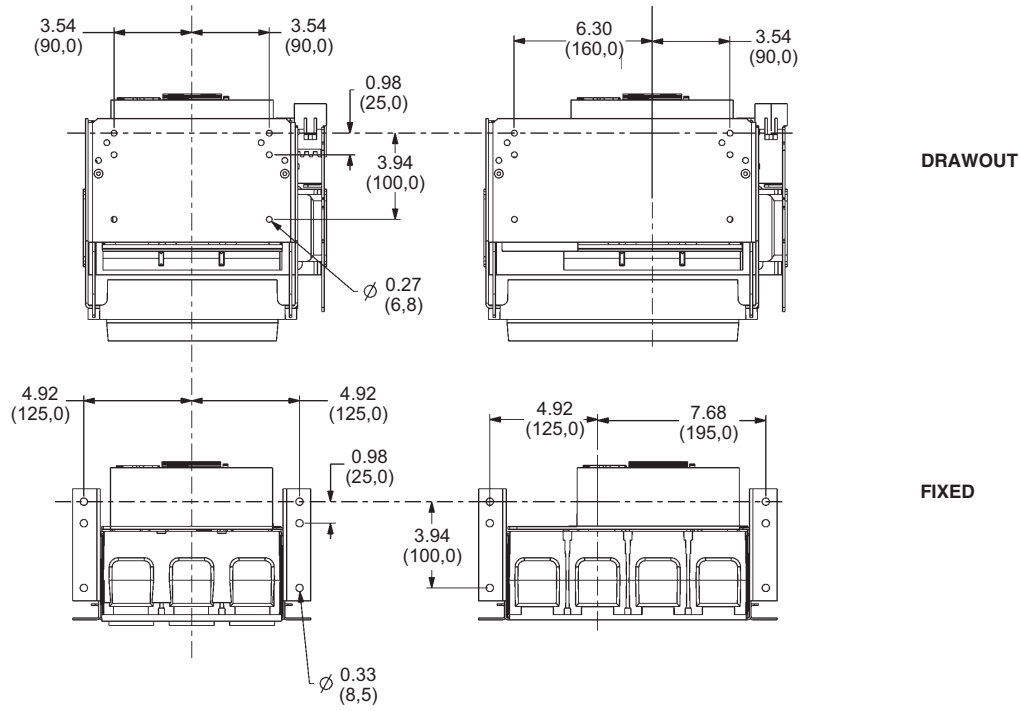

# Masterpact™ NT and NW Universal Power Circuit Breakers

## Masterpact NT Dimensional Drawings

### UL/ANSI Four-Pole Drawout Circuit Breakers

**Figure 38: 800–1200 A and 1600 A Masterpact NT UL/ANSI Four-Pole Drawout—Master Drawing**

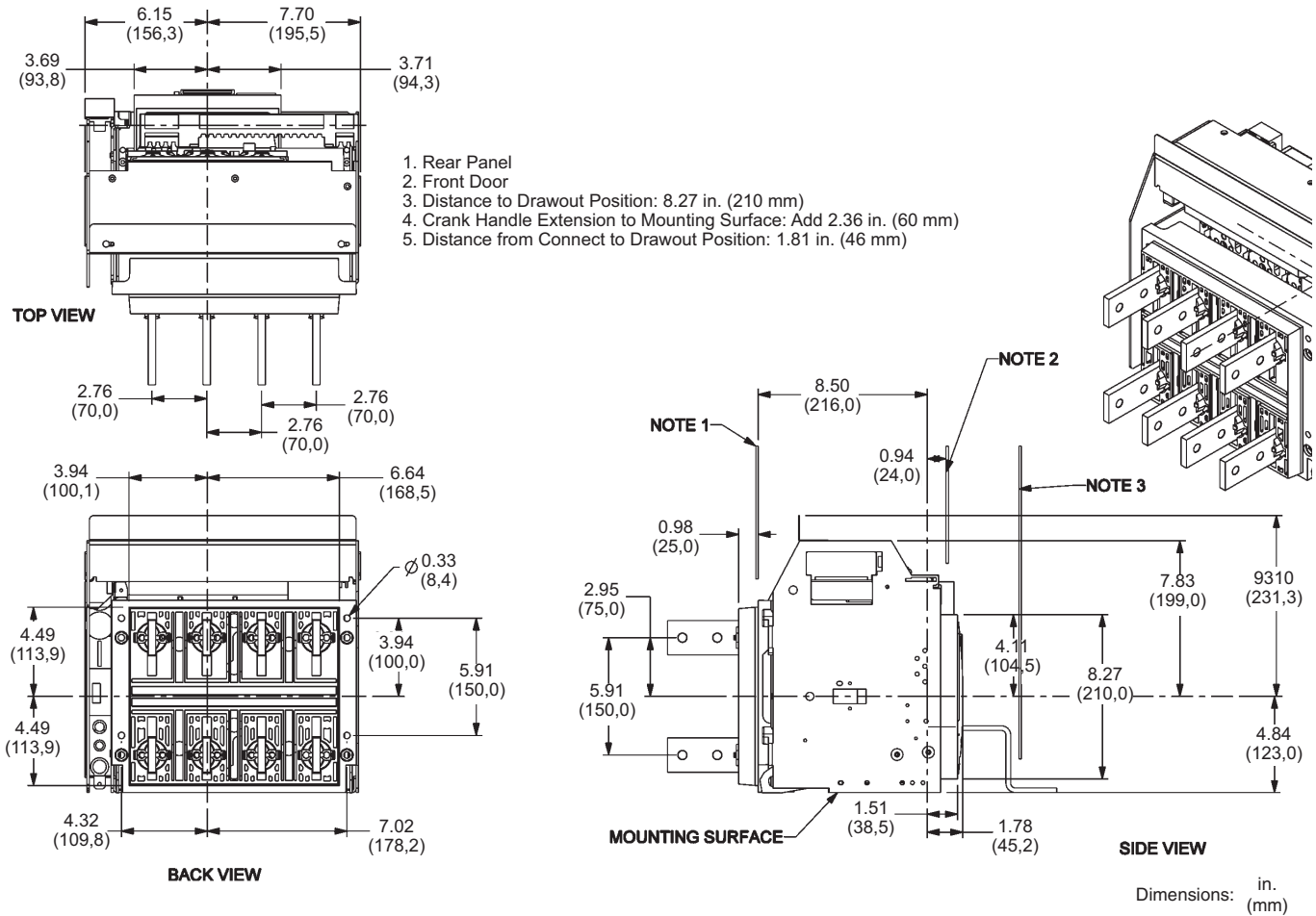

# Masterpact™ NT and NW Universal Power Circuit Breakers

## Masterpact NT Dimensional Drawings

Figure 39: 800–1200 A Masterpact NT UL/ANSI Four-Pole Drawout—RCTH Rear-Connected “T” Horizontal

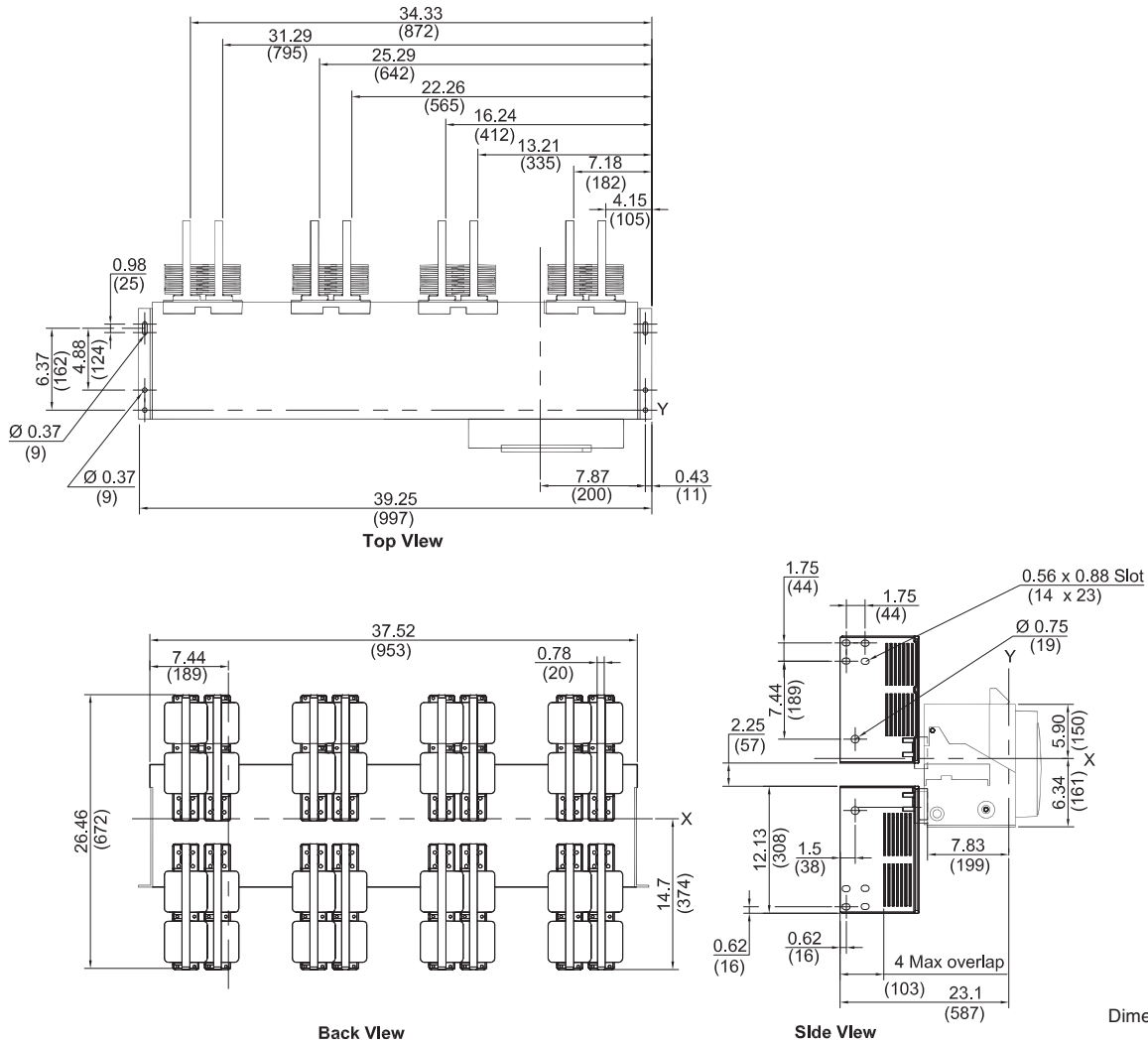

Dimensions: in. (mm)



# Masterpact™ NT and NW Universal Power Circuit Breakers

## Masterpact NT Dimensional Drawings

**Figure 40: 800–1200 A Masterpact NT UL/ANSI Four-Pole Drawout—RCTV Rear-Connected “T” Vertical**

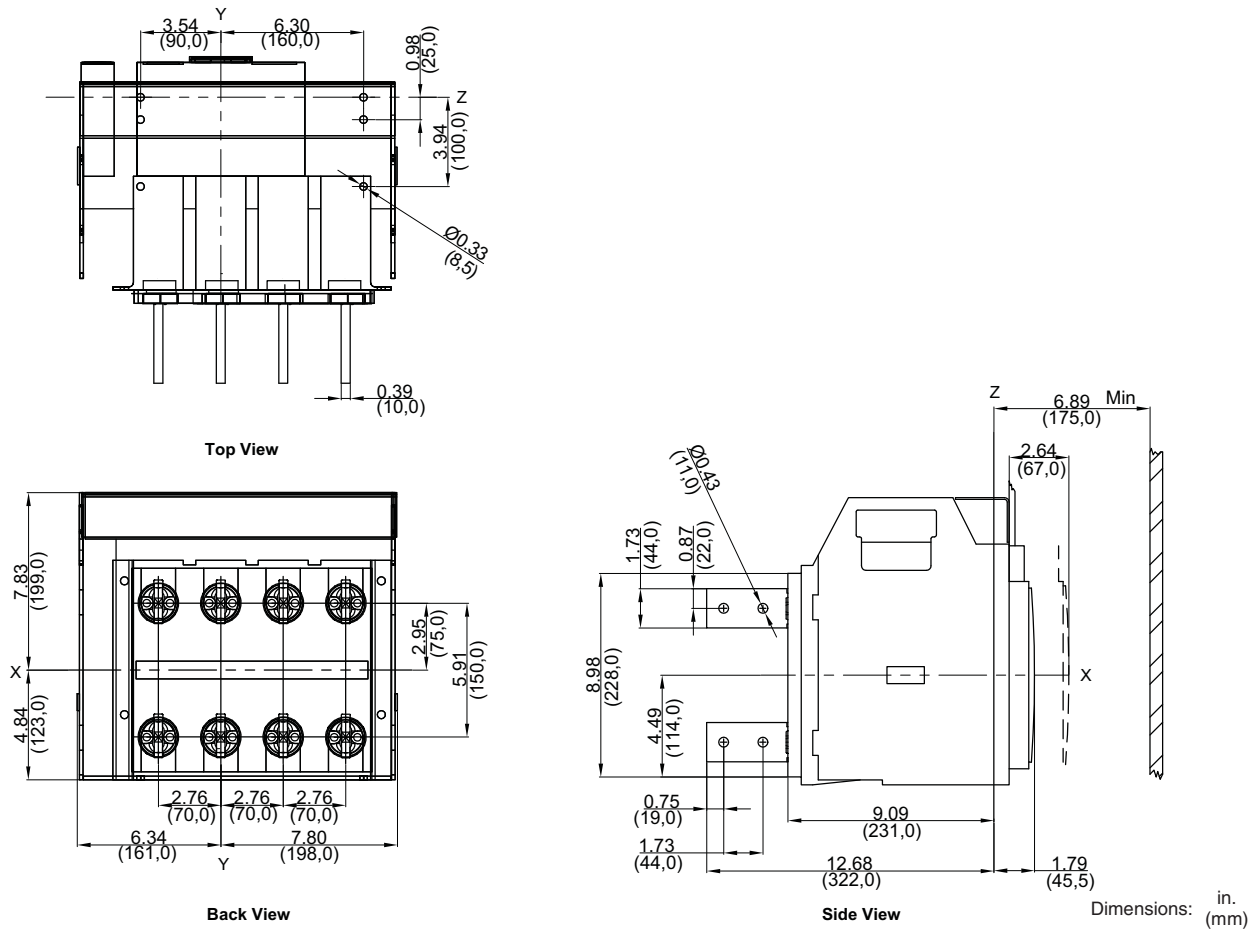

# Masterpact™ NT and NW Universal Power Circuit Breakers

## Masterpact NT Dimensional Drawings

Figure 41: 800–1200 A Masterpact NT UL/ANSI Four-Pole Drawout—FCF Front-Connected Flat

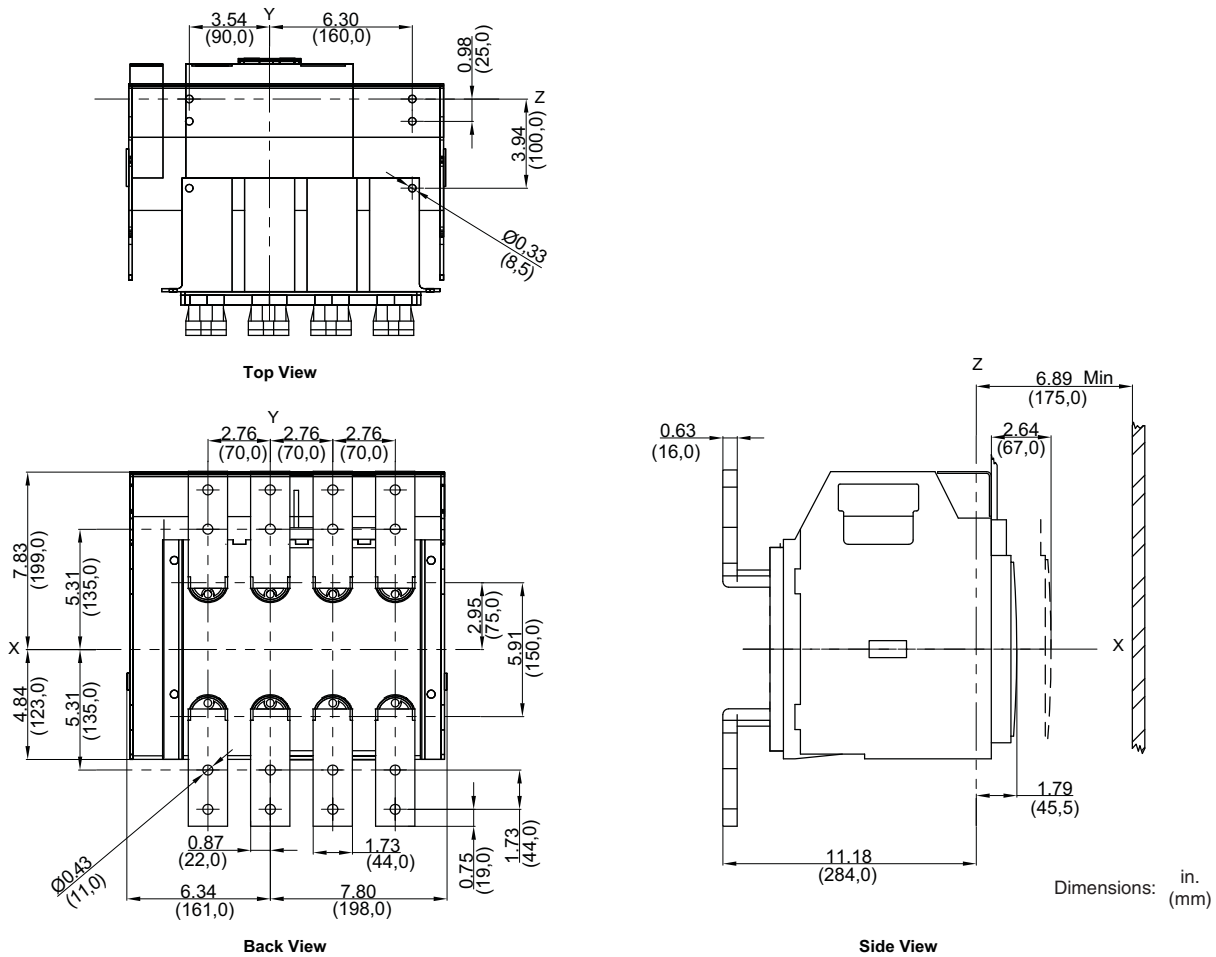
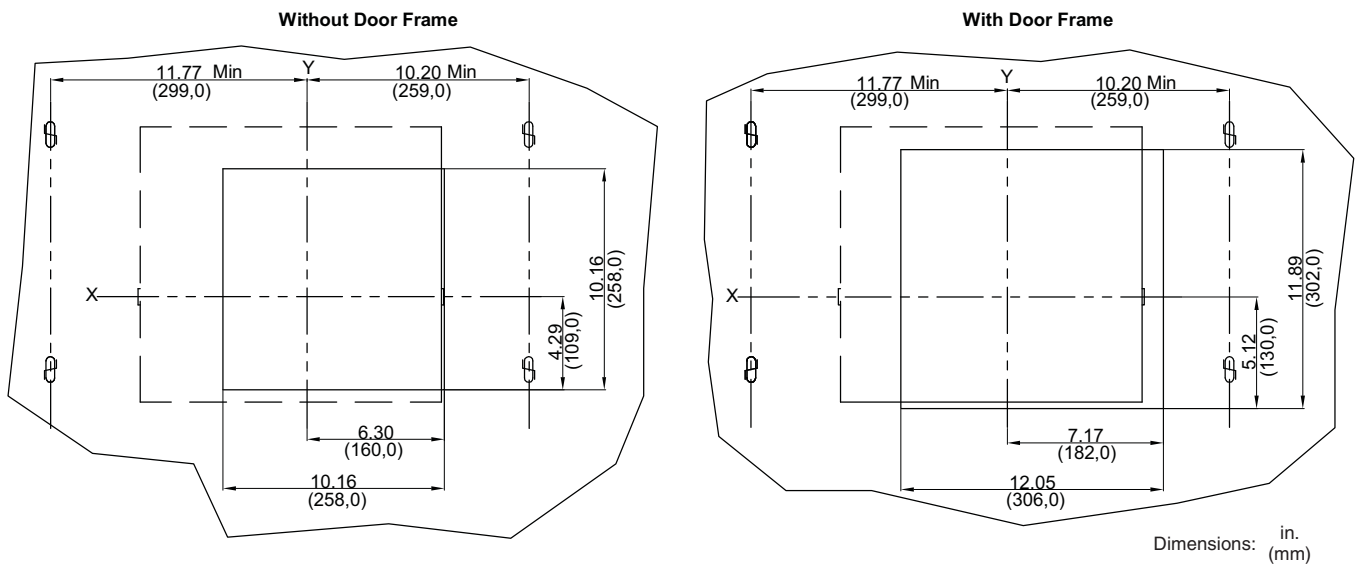

Figure 42: 800–1200 A Masterpact NT UL/ANSI Four-Pole Drawout—Door Cutout Dimensions



# Masterpact™ NT and NW Universal Power Circuit Breakers

## Masterpact NT Dimensional Drawings

**Figure 43: 800–1200 A Masterpact NT UL/ANSI Drawout—Pan Dimensions**

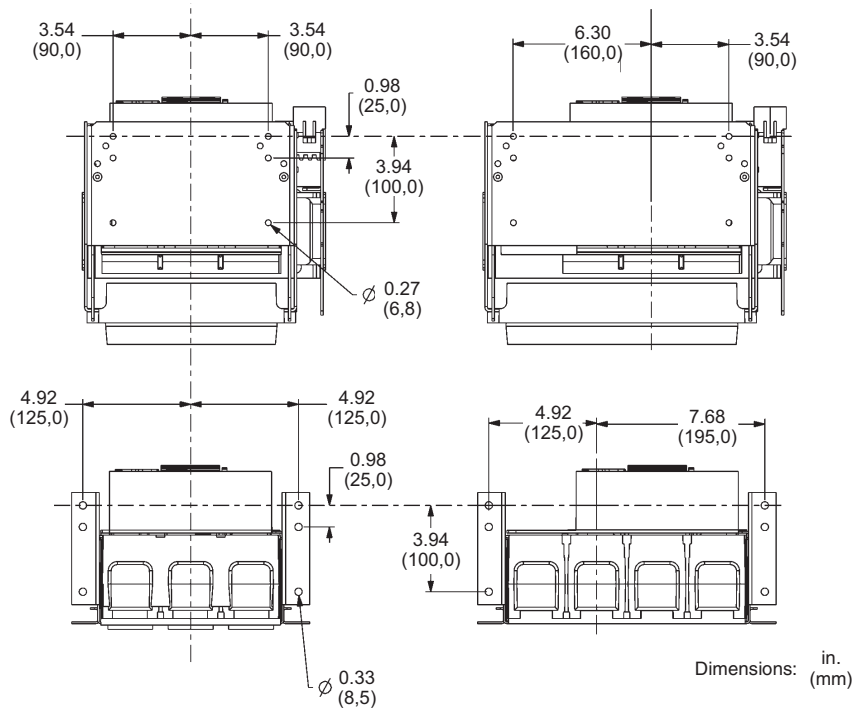

**Masterpact™ NT and NW Universal Power Circuit Breakers**  
**Masterpact NT Dimensional Drawings**

**UL/ANSI Four-Pole Fixed Circuit Breakers**

**Figure 44: 800–1200 A Masterpact NT UL/ANSI Four-Pole Fixed—Master Drawing**

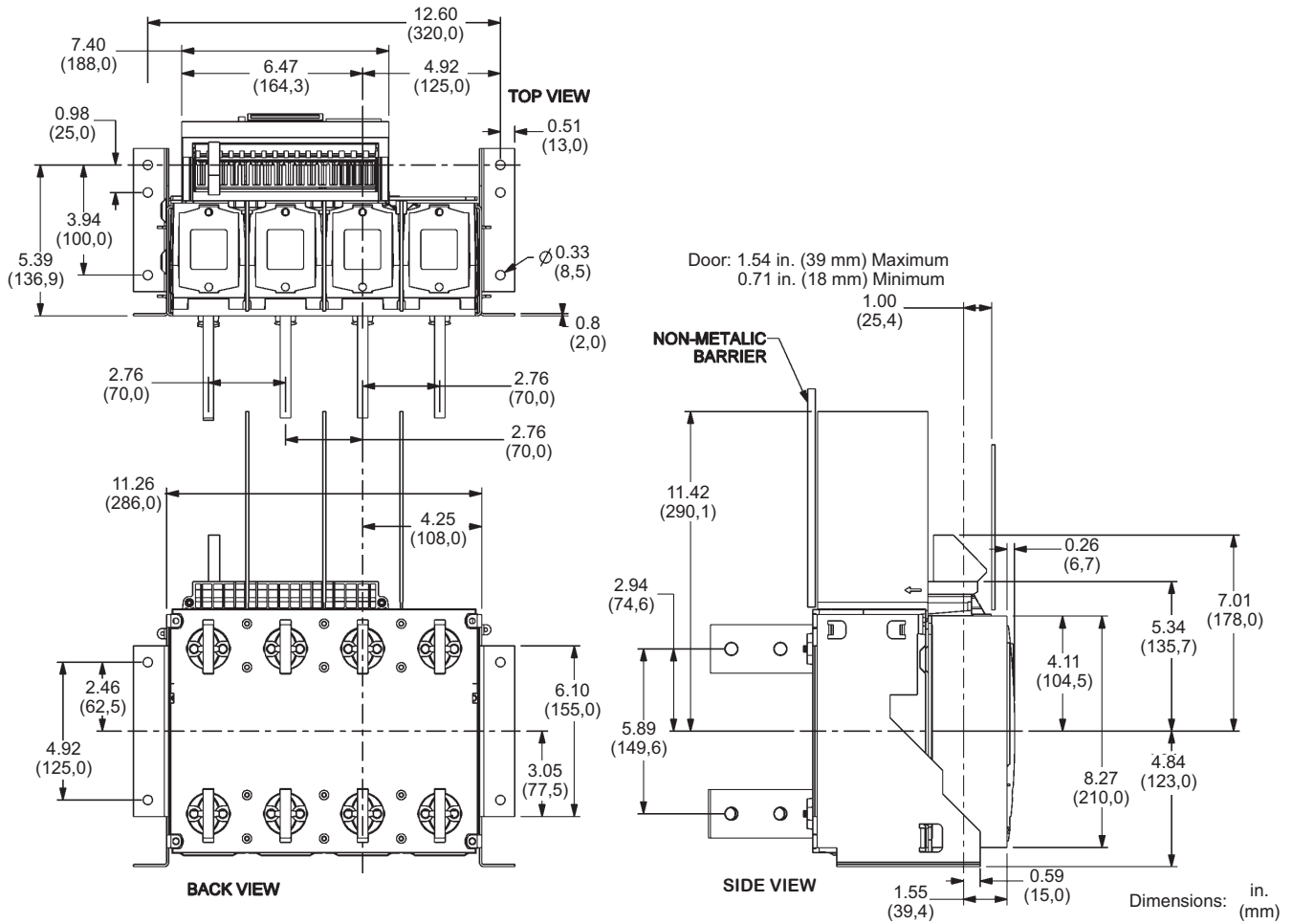

# Masterpact™ NT and NW Universal Power Circuit Breakers

## Masterpact NT Dimensional Drawings

**Figure 45: 800–1200 A Masterpact NT UL/ANSI Four-Pole Fixed—RCTH Rear-Connected “T” Horizontal**

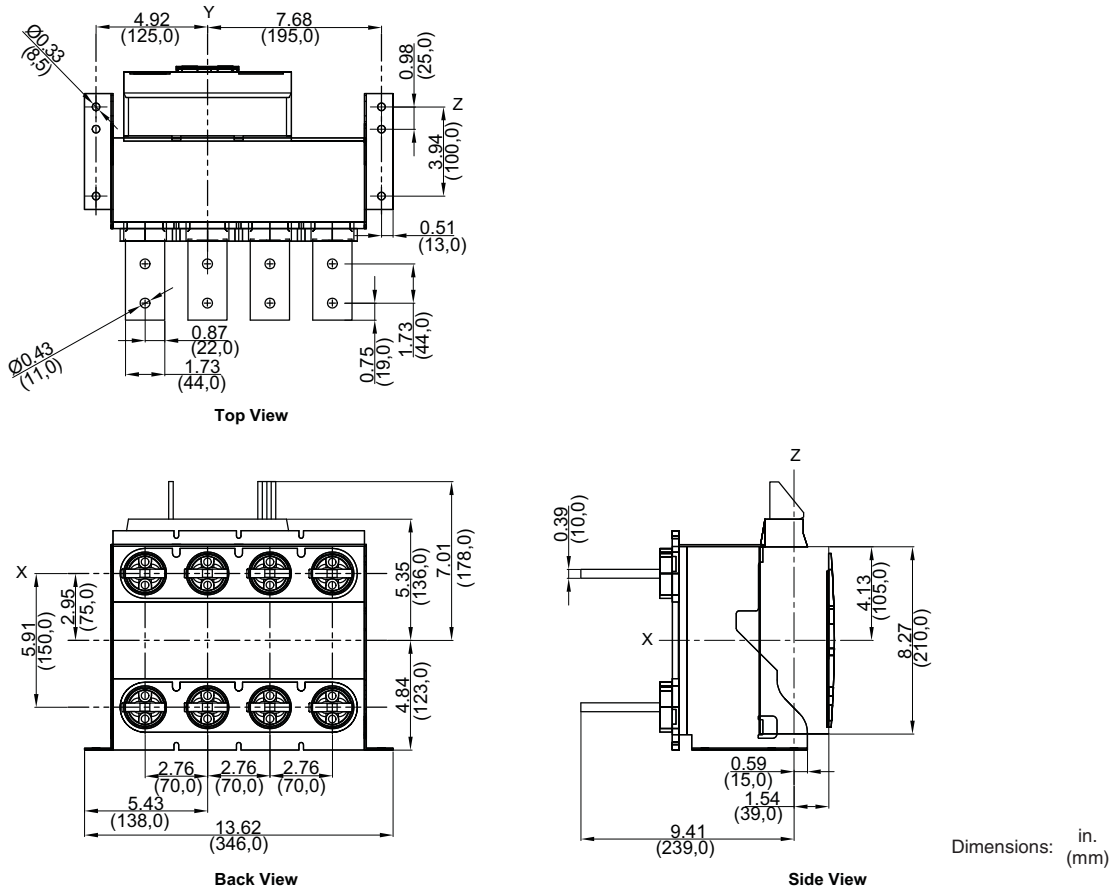

# Masterpact™ NT and NW Universal Power Circuit Breakers

## Masterpact NT Dimensional Drawings

Figure 46: 800–1200 A Masterpact NT UL/ANSI Four-Pole Fixed—RCTV Rear-Connected “T” Vertical

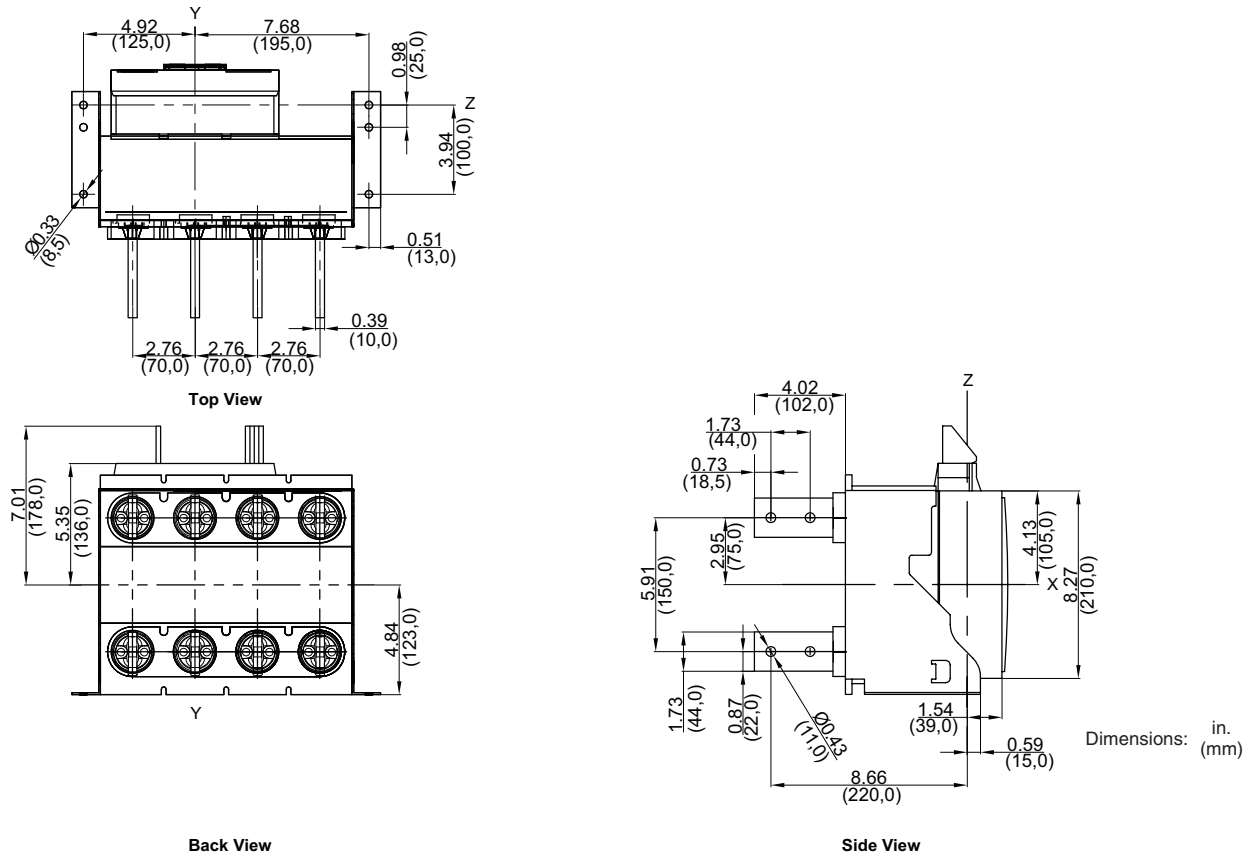

# Masterpact™ NT and NW Universal Power Circuit Breakers

## Masterpact NT Dimensional Drawings

Figure 47: 800–1200 A Masterpact NT UL/ANSI Four-Pole Fixed—FCF Front-Connected Flat

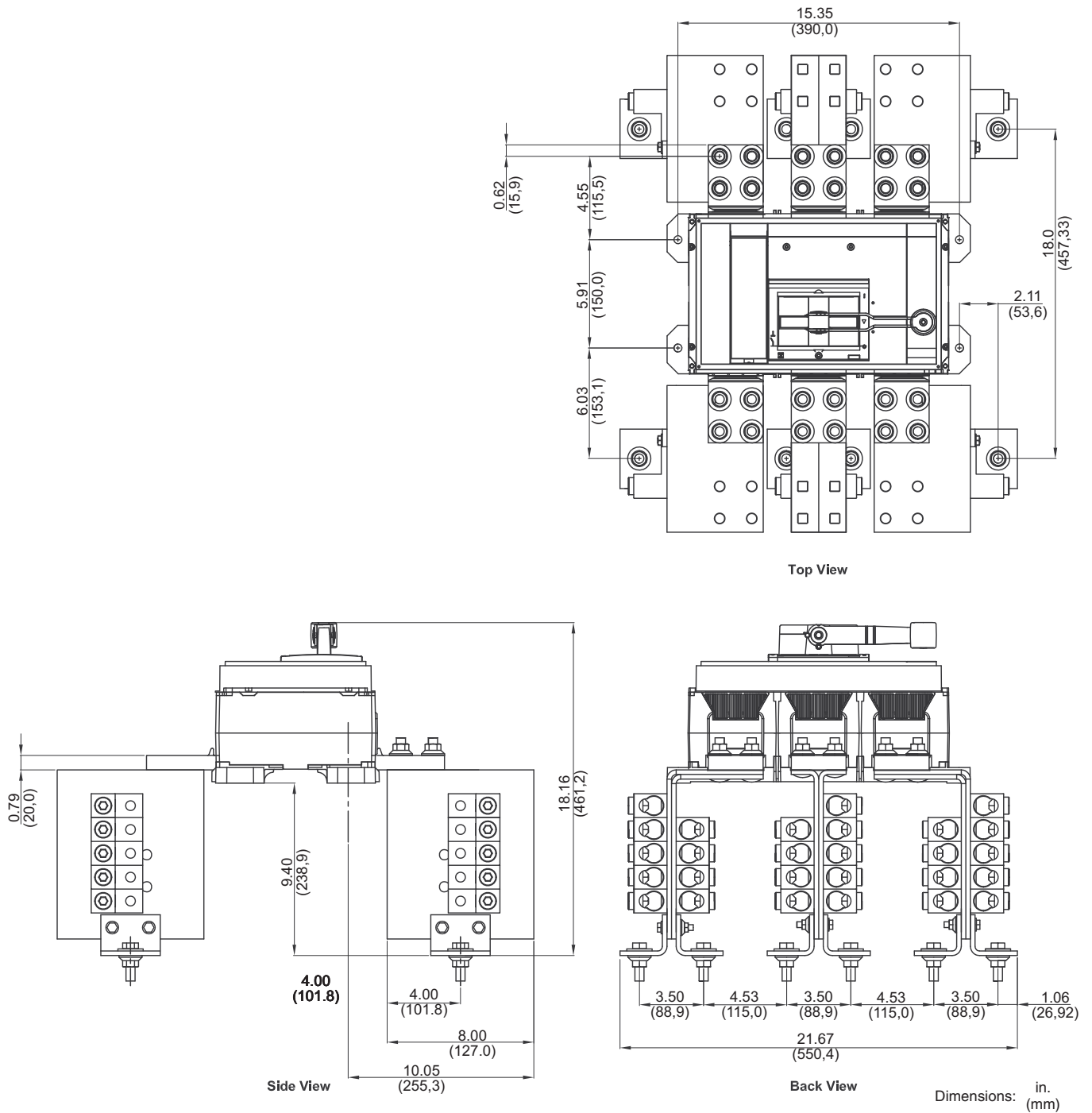

# Masterpact™ NT and NW Universal Power Circuit Breakers

## Masterpact NT Dimensional Drawings

Figure 48: 800–1200 A Masterpact NT UL/ANSI Four-Pole Fixed—Door Cutout Dimensions

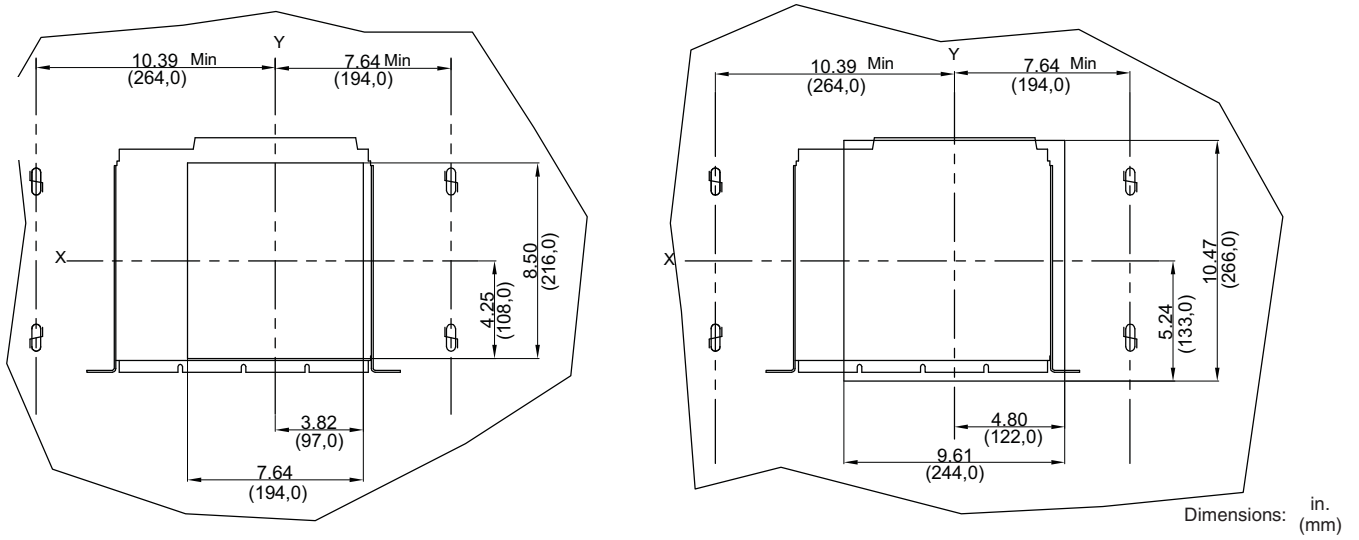
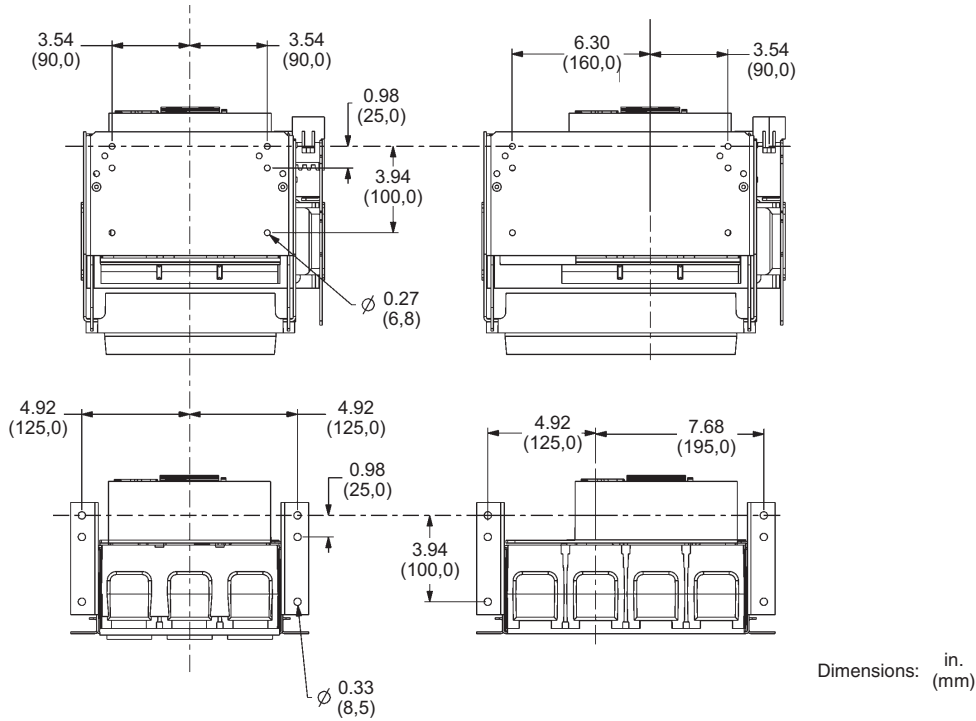

Figure 49: 800–1200 A Masterpact NT UL/ANSI Fixed—Pan Dimensions





# Masterpact™ NT and NW Universal Power Circuit Breakers

## Masterpact NT Dimensional Drawings

### IEC Three-Pole Drawout Circuit Breakers

**Figure 50: 800–1600 A Masterpact NT Three-Pole Drawout—Master Drawing**

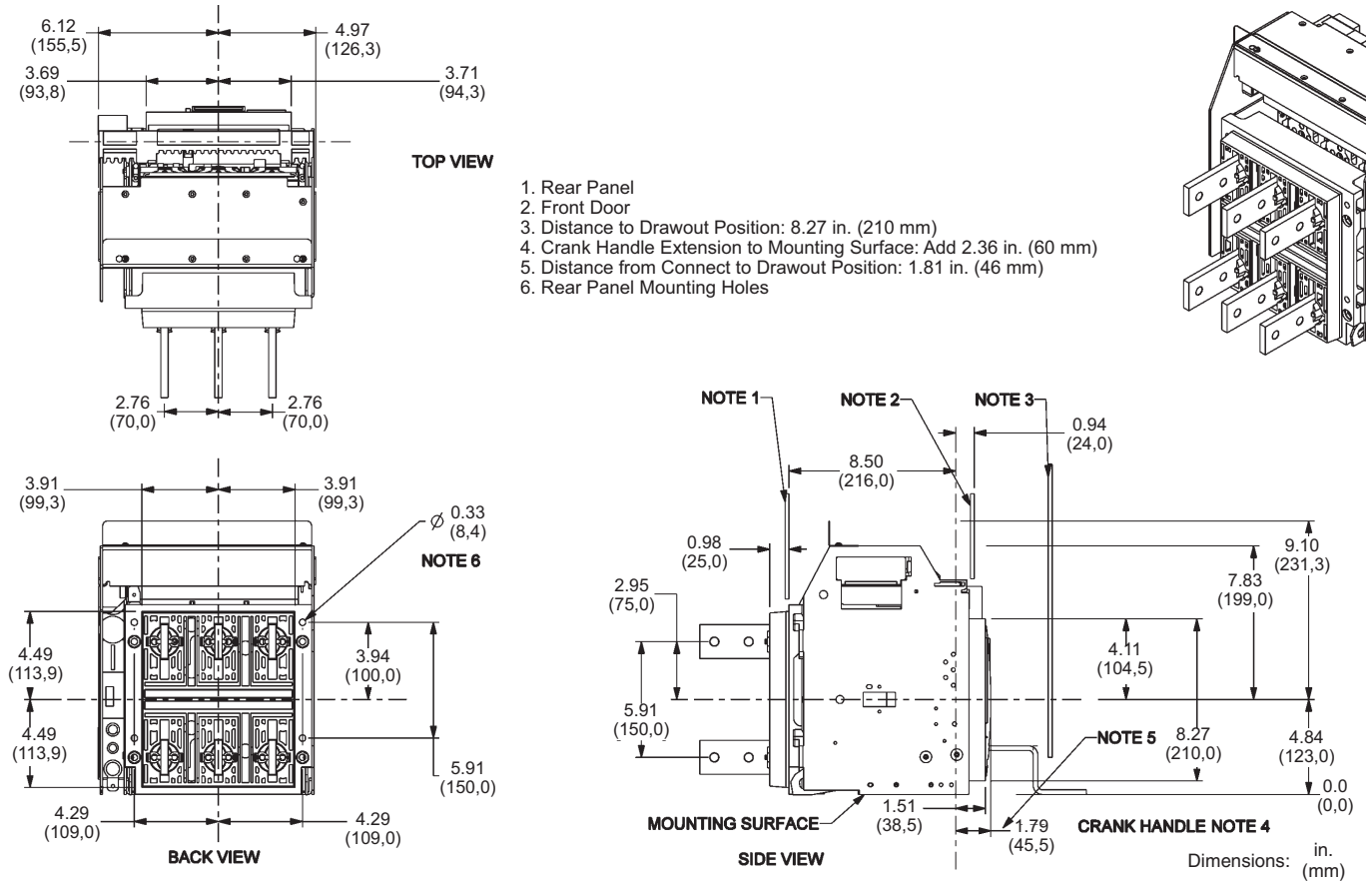

1. Rear Panel
2. Front Door
3. Distance to Drawout Position: 8.27 in. (210 mm)
4. Crank Handle Extension to Mounting Surface: Add 2.36 in. (60 mm)
5. Distance from Connect to Drawout Position: 1.81 in. (46 mm)
6. Rear Panel Mounting Holes

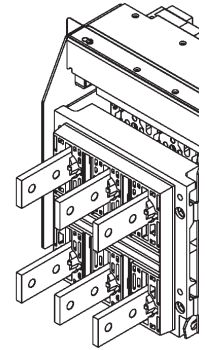

# Masterpact™ NT and NW Universal Power Circuit Breakers

## Masterpact NT Dimensional Drawings

Figure 51: 800–1600 A Masterpact NT IEC Three-Pole Drawout—RCTV Rear-Connected “T” Vertical

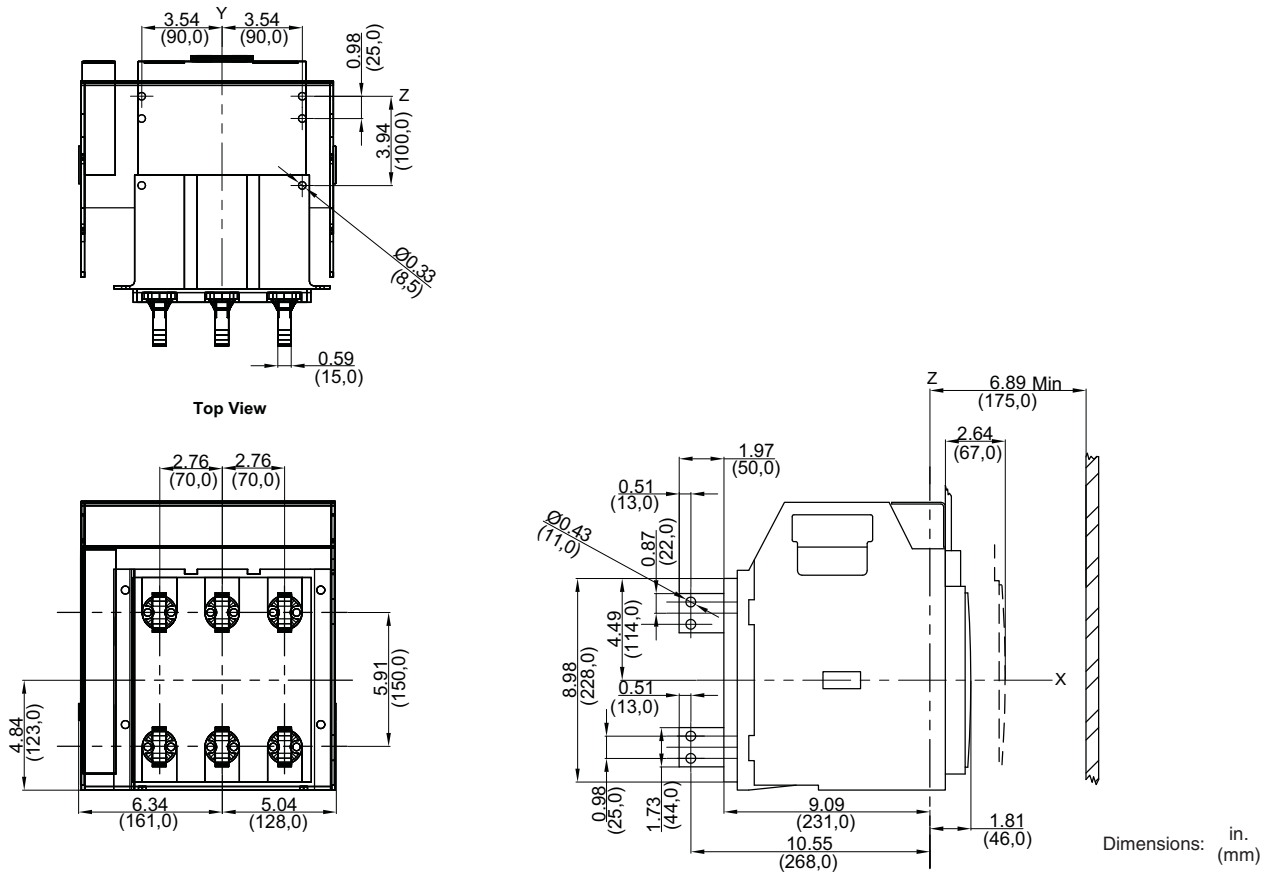

# Masterpact™ NT and NW Universal Power Circuit Breakers

## Masterpact NT Dimensional Drawings

**Figure 52: 800–1600 A Masterpact NT IEC Three-Pole Drawout—RCTH Rear-Connected “T” Horizontal**

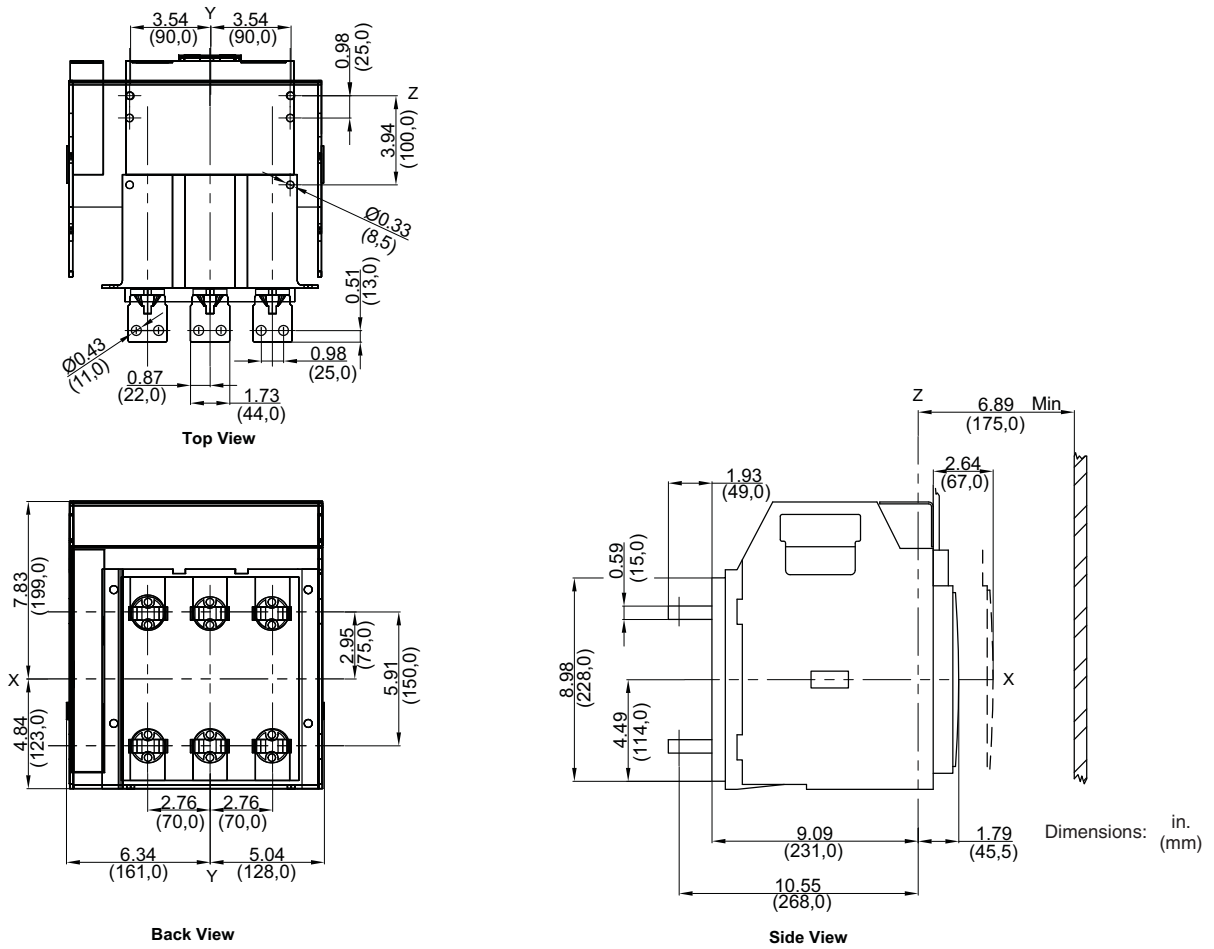

# Masterpact™ NT and NW Universal Power Circuit Breakers

## Masterpact NT Dimensional Drawings

Figure 53: 800–1600 A Masterpact NT IEC Three-Pole Drawout—FCF Front-Connected Flat

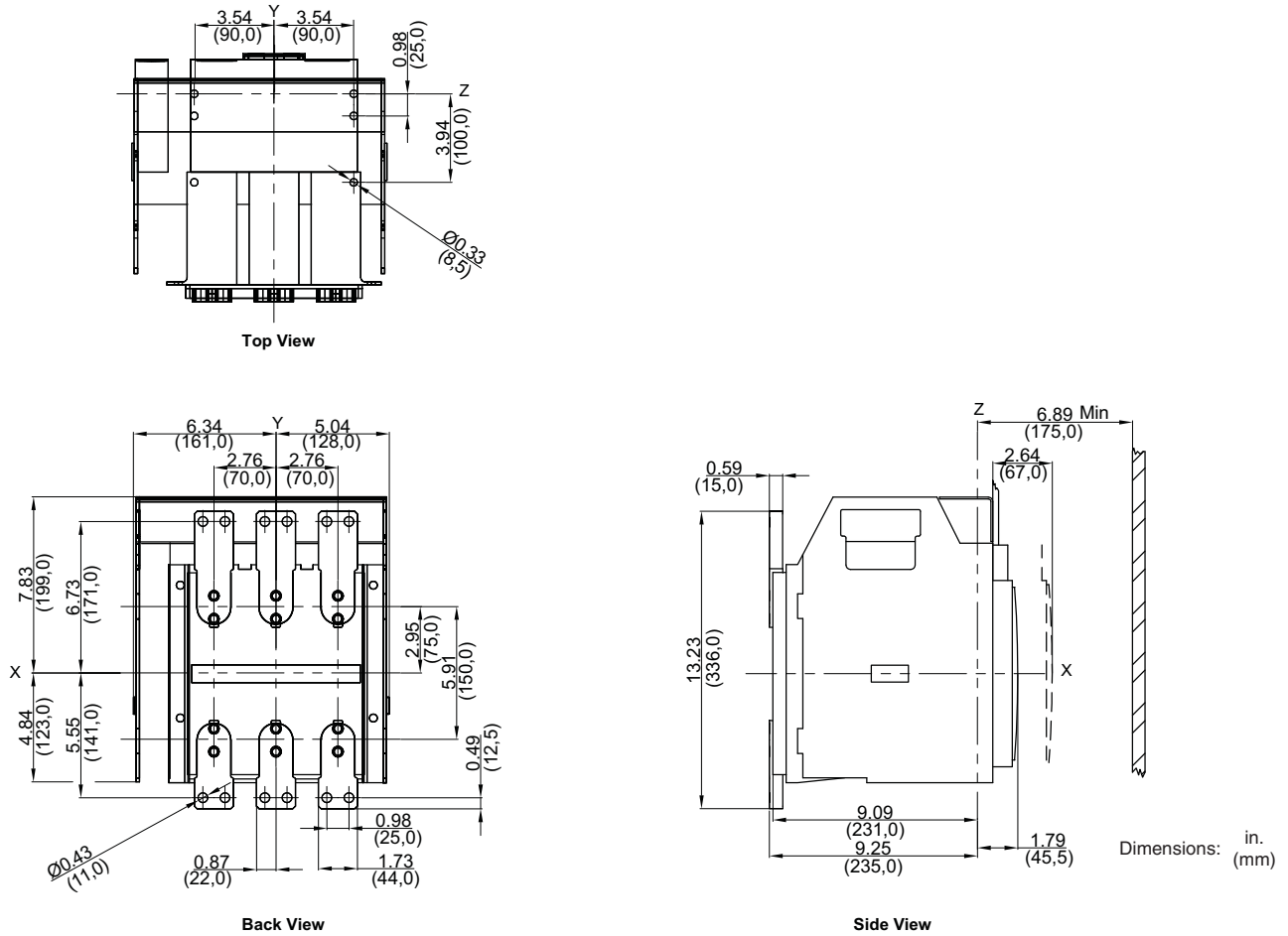
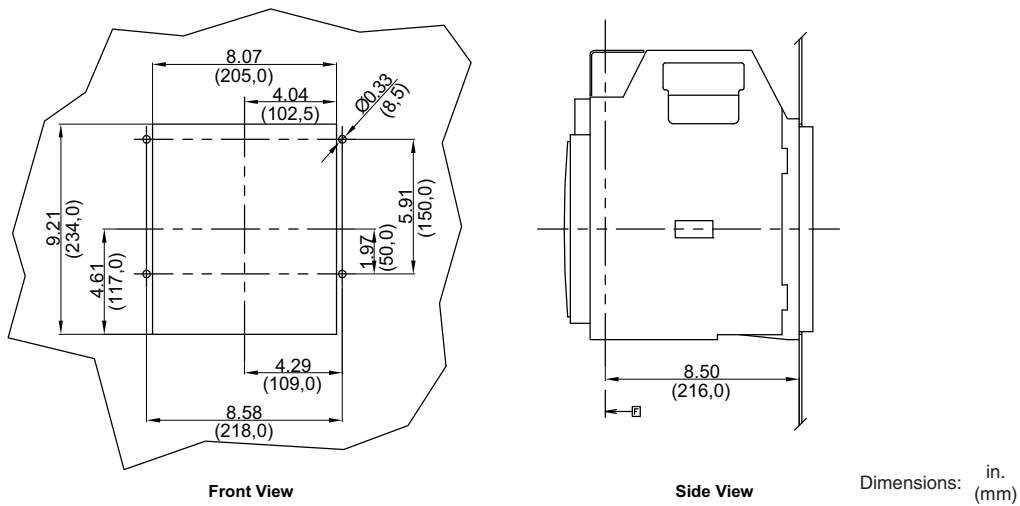

Figure 54: 800–1200 A Masterpact NT IEC Three-Pole Drawout—Rear Cutout Dimensions



# Masterpact™ NT and NW Universal Power Circuit Breakers

## Masterpact NT Dimensional Drawings

### IEC Three-Pole Fixed Circuit Breakers

**Figure 55: 800–1600 A Masterpact NT Three-Pole Fixed—Master Drawing**

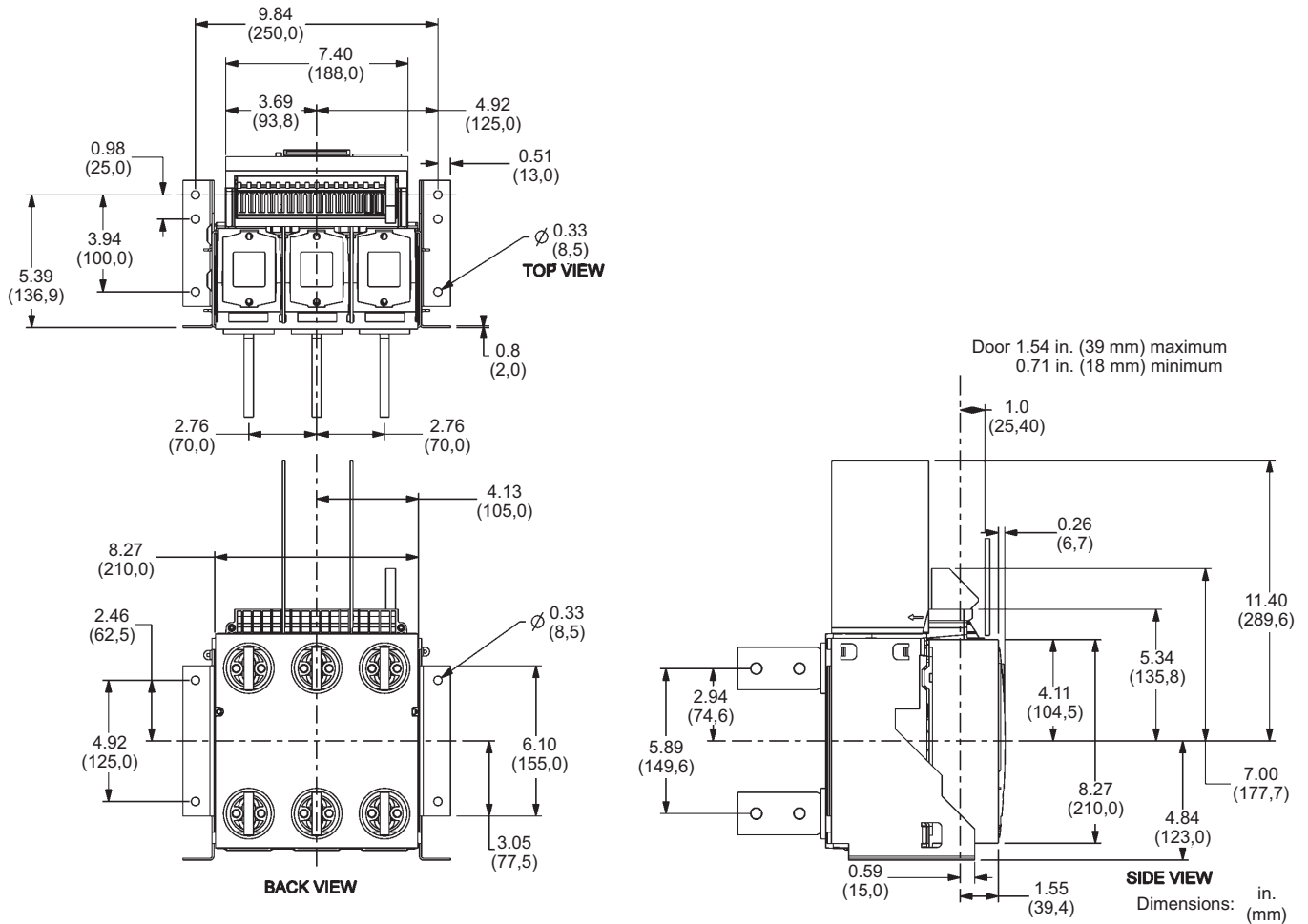

# Masterpact™ NT and NW Universal Power Circuit Breakers

## Masterpact NT Dimensional Drawings

Figure 56: 800–1600 A Masterpact NT IEC Three-Pole Fixed—RCTV Rear-Connected “T” Vertical

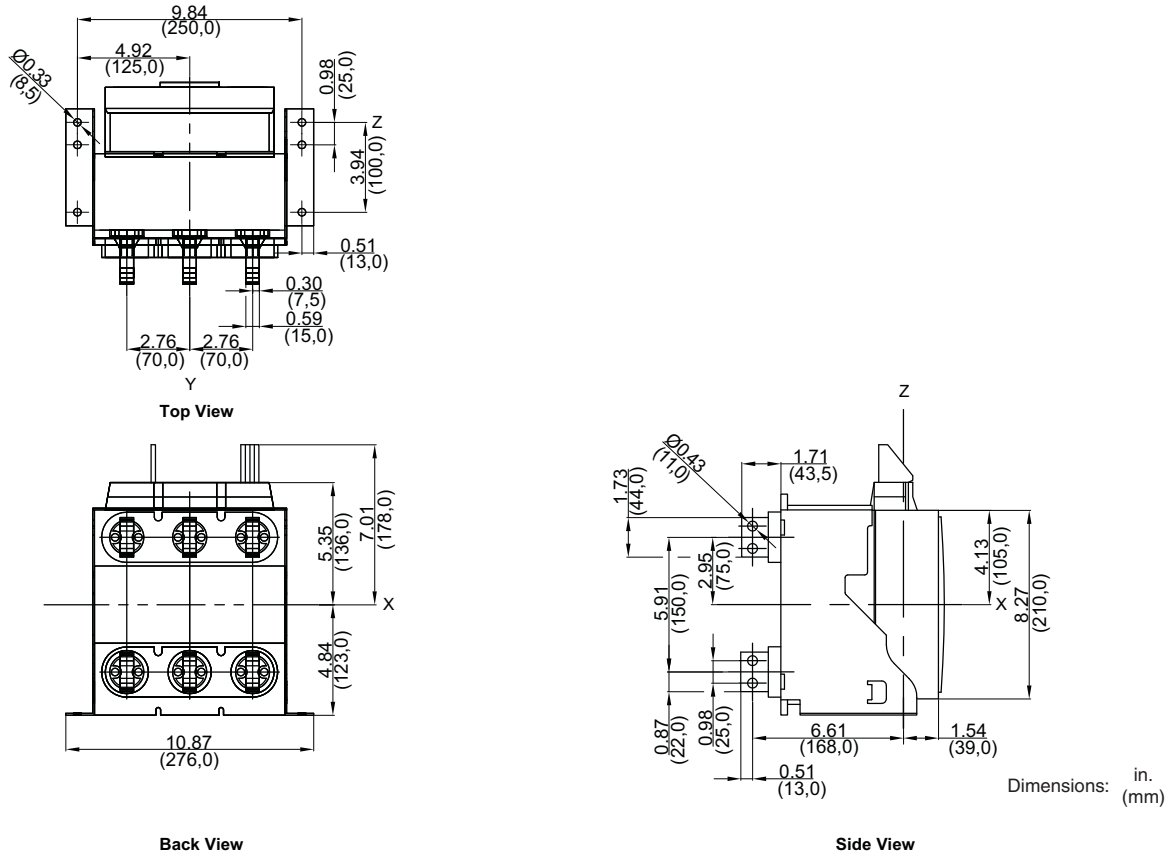

# Masterpact™ NT and NW Universal Power Circuit Breakers

## Masterpact NT Dimensional Drawings

**Figure 57: 800–1600 A Masterpact NT IEC Three-Pole Fixed—RCTH Rear-Connected “T” Horizontal**

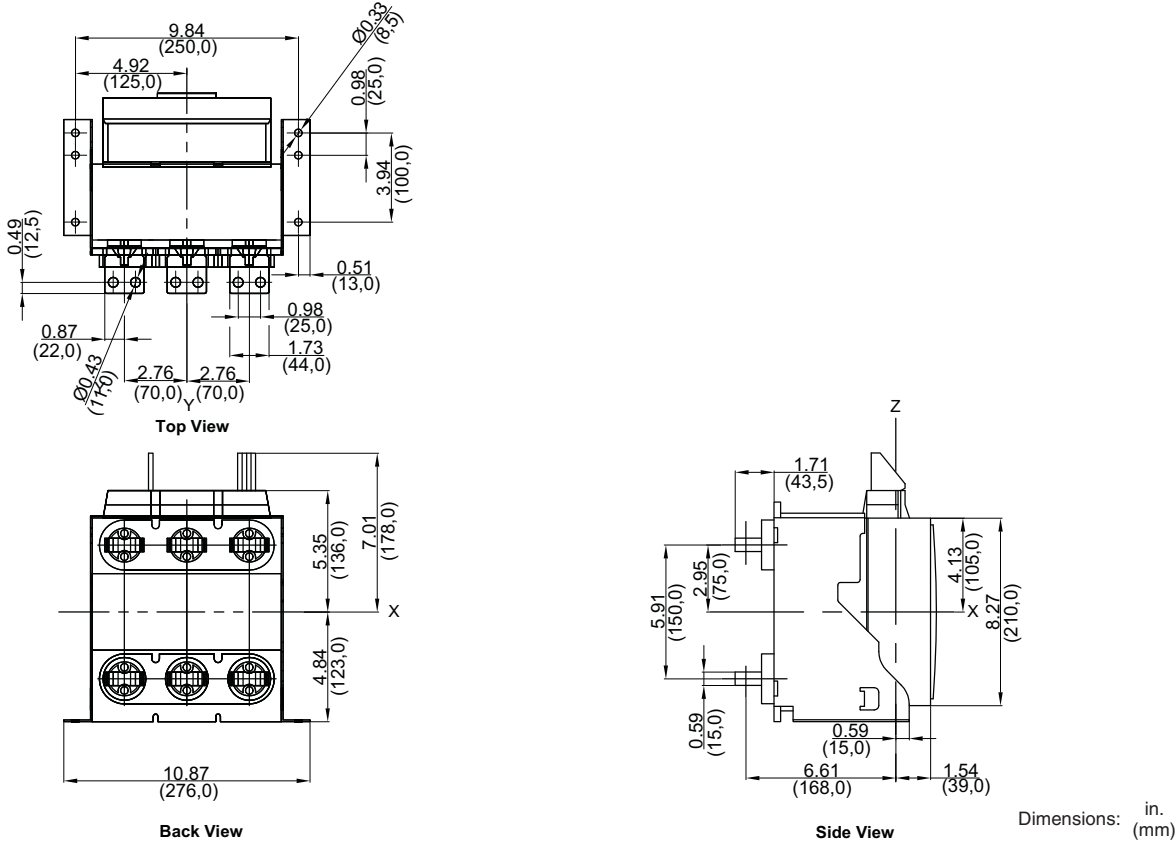

# Masterpact™ NT and NW Universal Power Circuit Breakers

## Masterpact NT Dimensional Drawings

Figure 58: 800–1600 A Masterpact NT IEC Three-Pole Fixed—FCF Front-Connected Flat

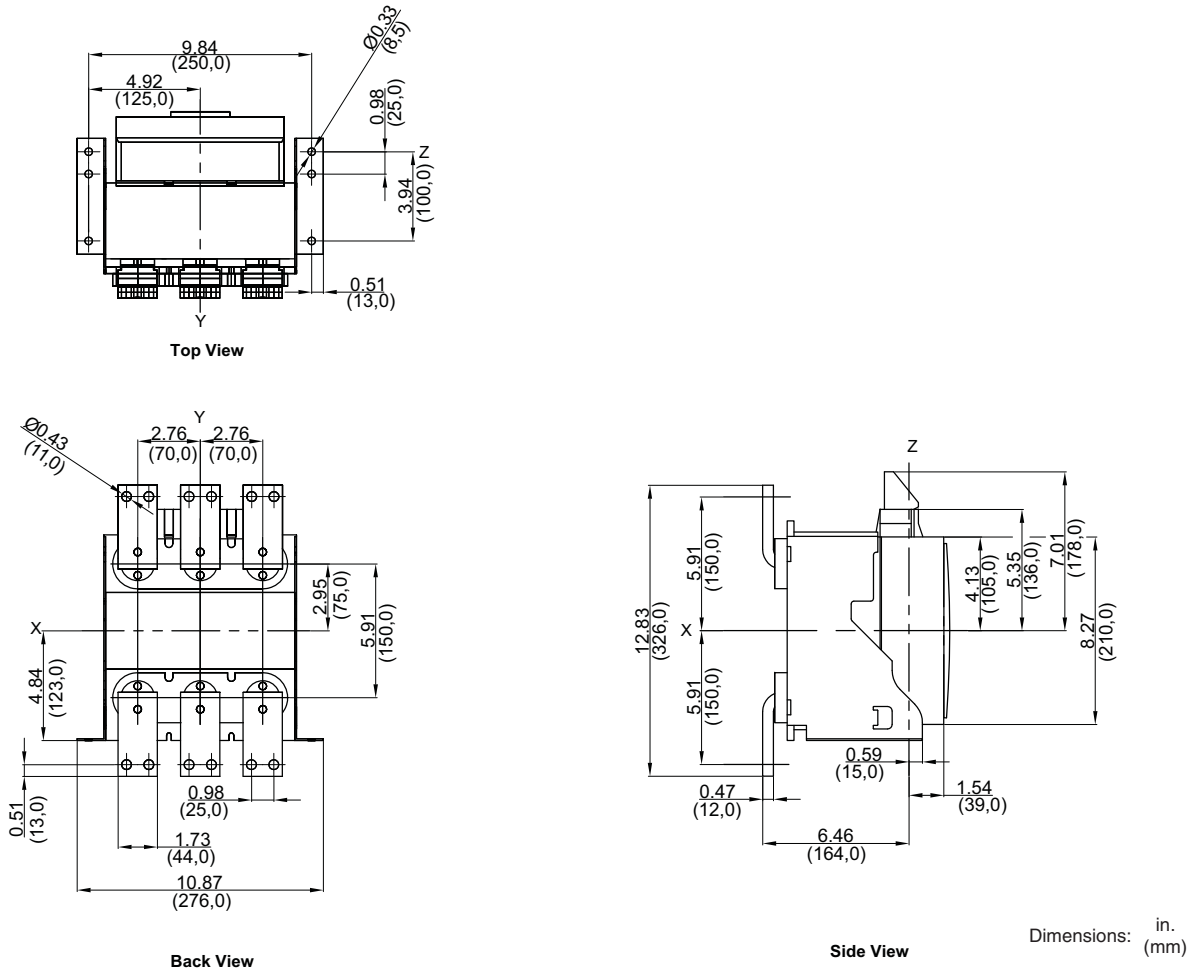



# Masterpact™ NT and NW Universal Power Circuit Breakers

## Masterpact NT Dimensional Drawings

**Figure 59: 800–1200 A Masterpact NT IEC Three-Pole Fixed—Rear Cutout Dimensions**

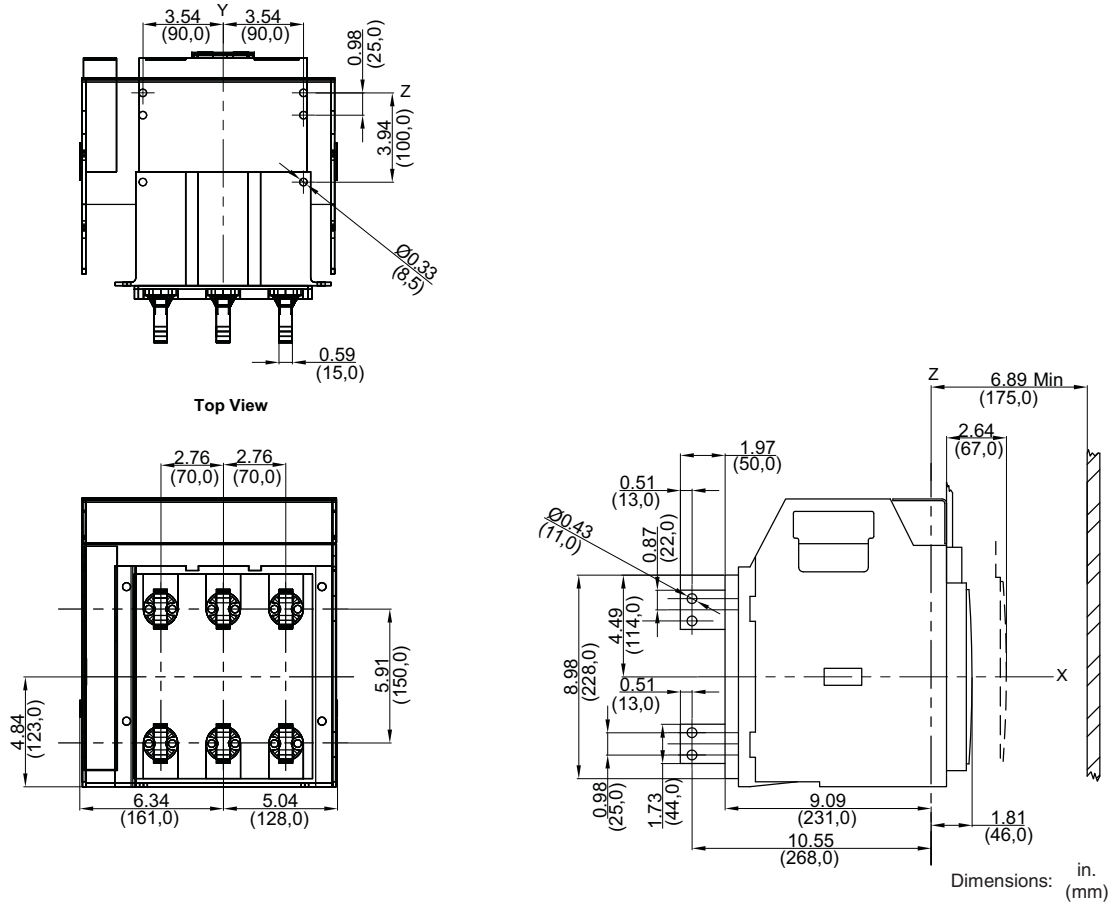

# Masterpact™ NT and NW Universal Power Circuit Breakers

## Masterpact NT Dimensional Drawings

### IEC Four-Pole Drawout Circuit Breakers

Figure 60: 800–1600 A Masterpact NT Four-Pole Drawout—Master Drawing

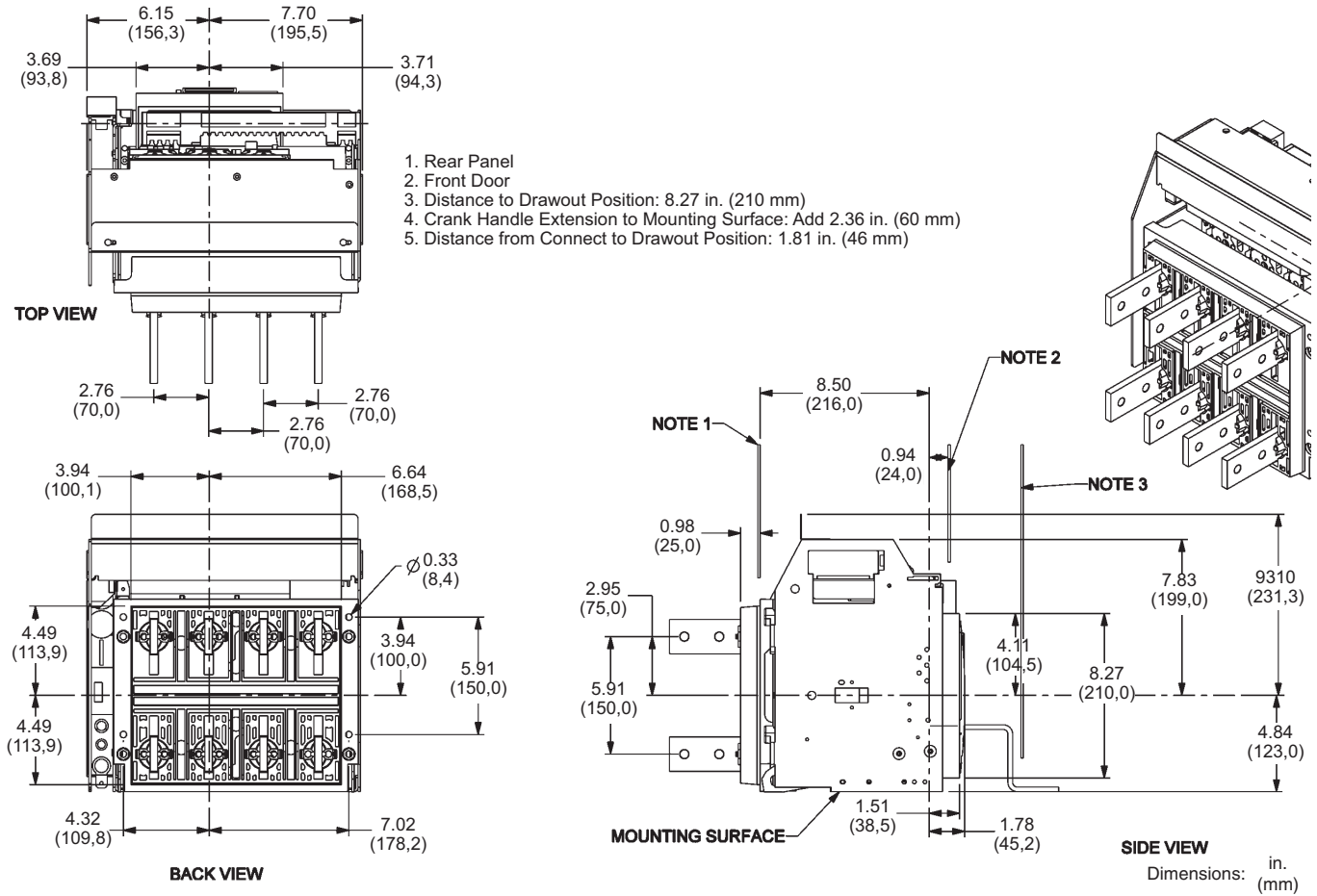

# Masterpact™ NT and NW Universal Power Circuit Breakers

## Masterpact NT Dimensional Drawings

**Figure 61: 800–1600 A Masterpact NT IEC Four-Pole Drawout—RCTV Rear-Connected “T” Vertical**

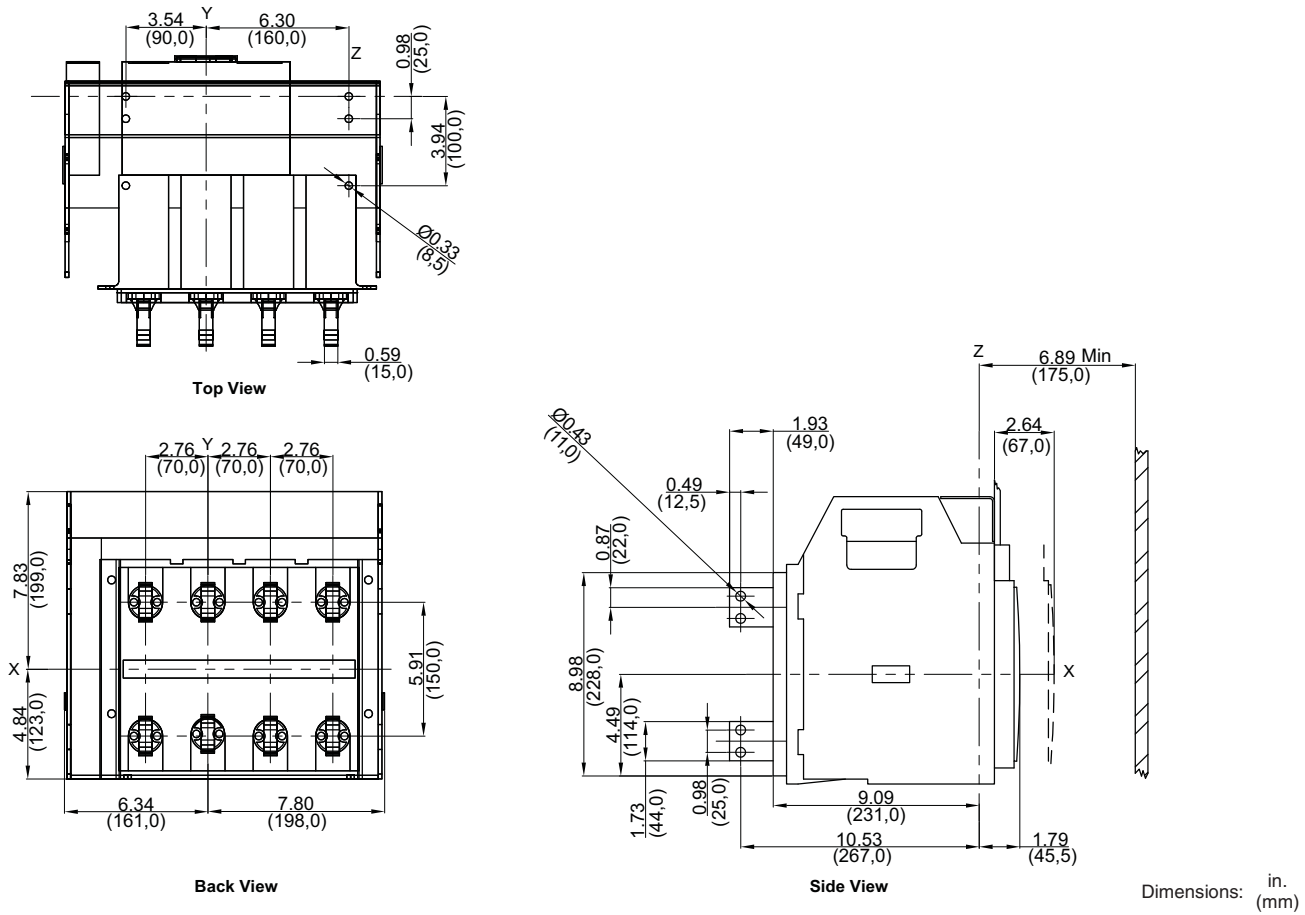

# Masterpact™ NT and NW Universal Power Circuit Breakers

## Masterpact NT Dimensional Drawings

Figure 62: 800–1600 A Masterpact NT IEC Four-Pole Drawout—RCTH Rear-Connected “T” Horizontal

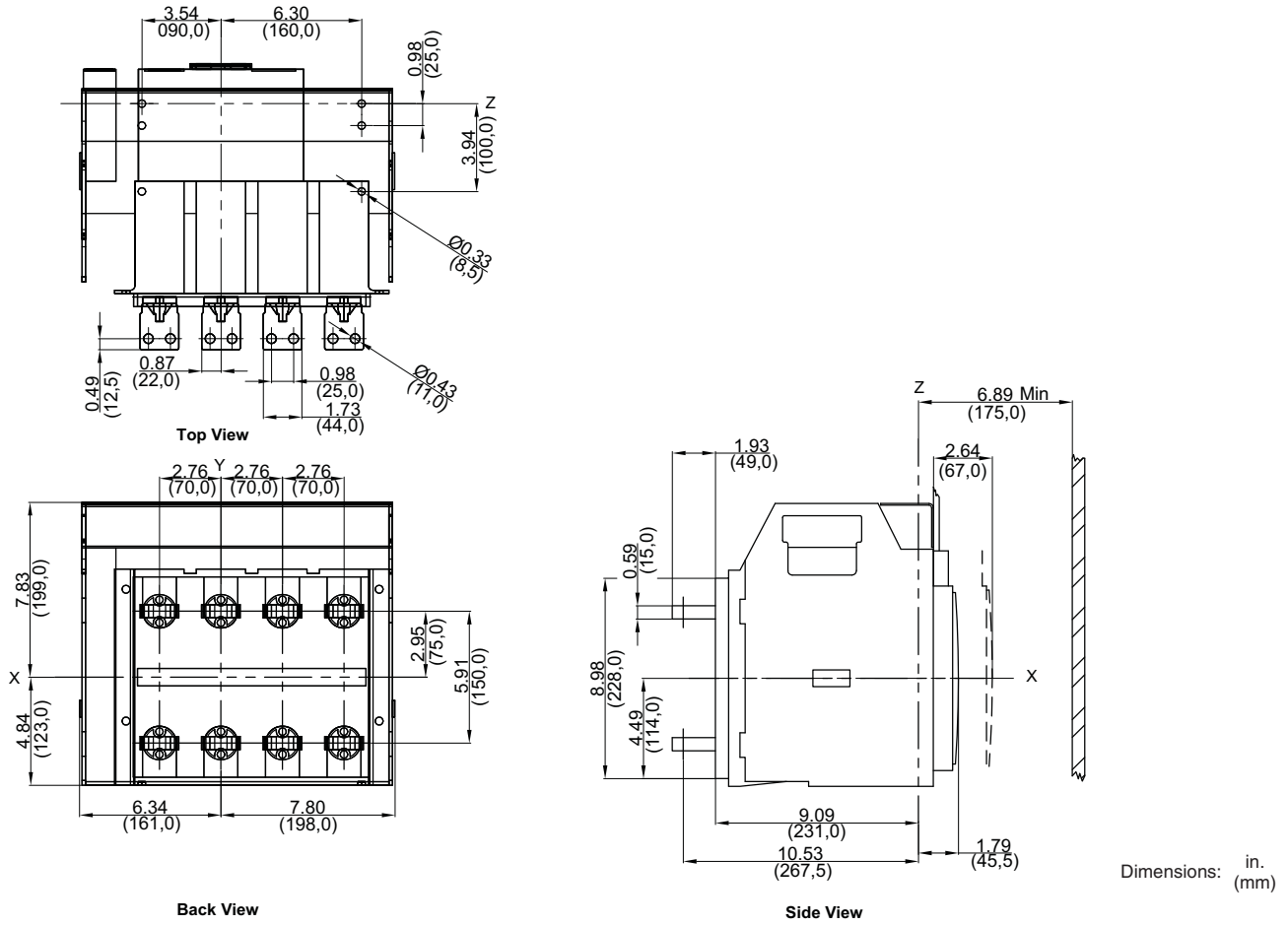

# Masterpact™ NT and NW Universal Power Circuit Breakers

## Masterpact NT Dimensional Drawings

**Figure 63: 800–1600 A Masterpact NT IEC Four-Pole Drawout—FCF Front-Connected Flat**

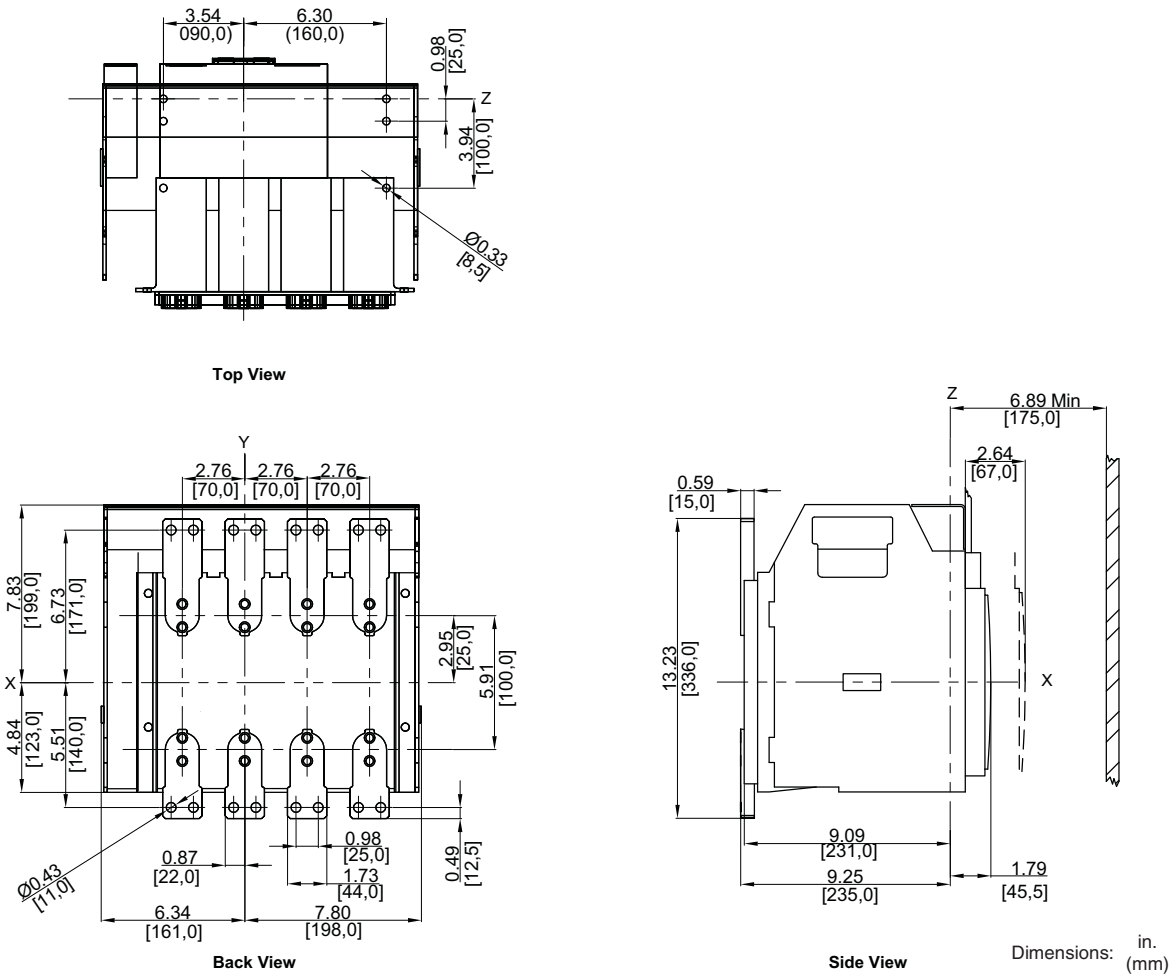

**Figure 64: 800–1200 A Masterpact NT IEC Four-Pole Drawout—Rear Cutout Dimensions**

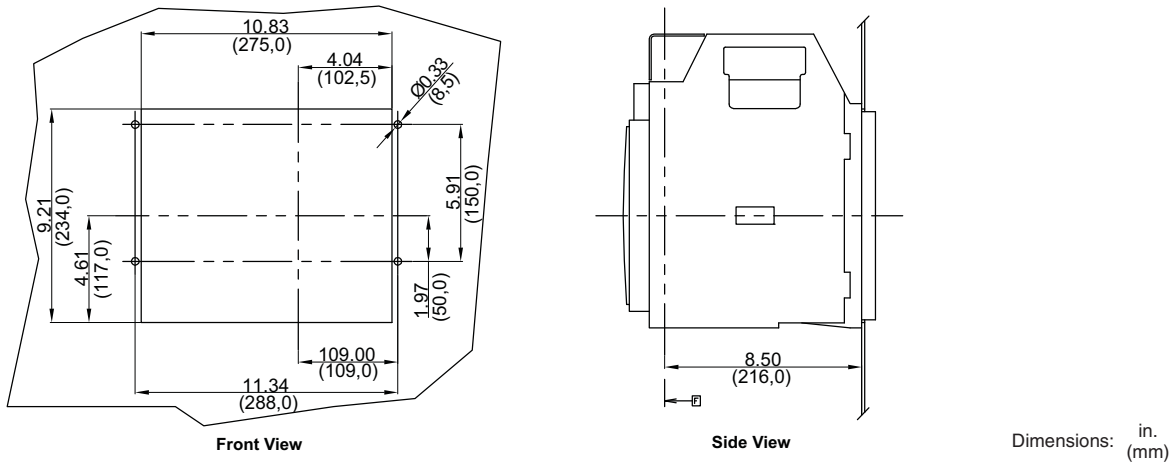

**Masterpact™ NT and NW Universal Power Circuit Breakers**  
**Masterpact NT Dimensional Drawings**

**IEC Four-Pole Fixed Circuit Breakers**

**Figure 65: 800–1600 A Masterpact NT Four-Pole Fixed—Master Drawing**

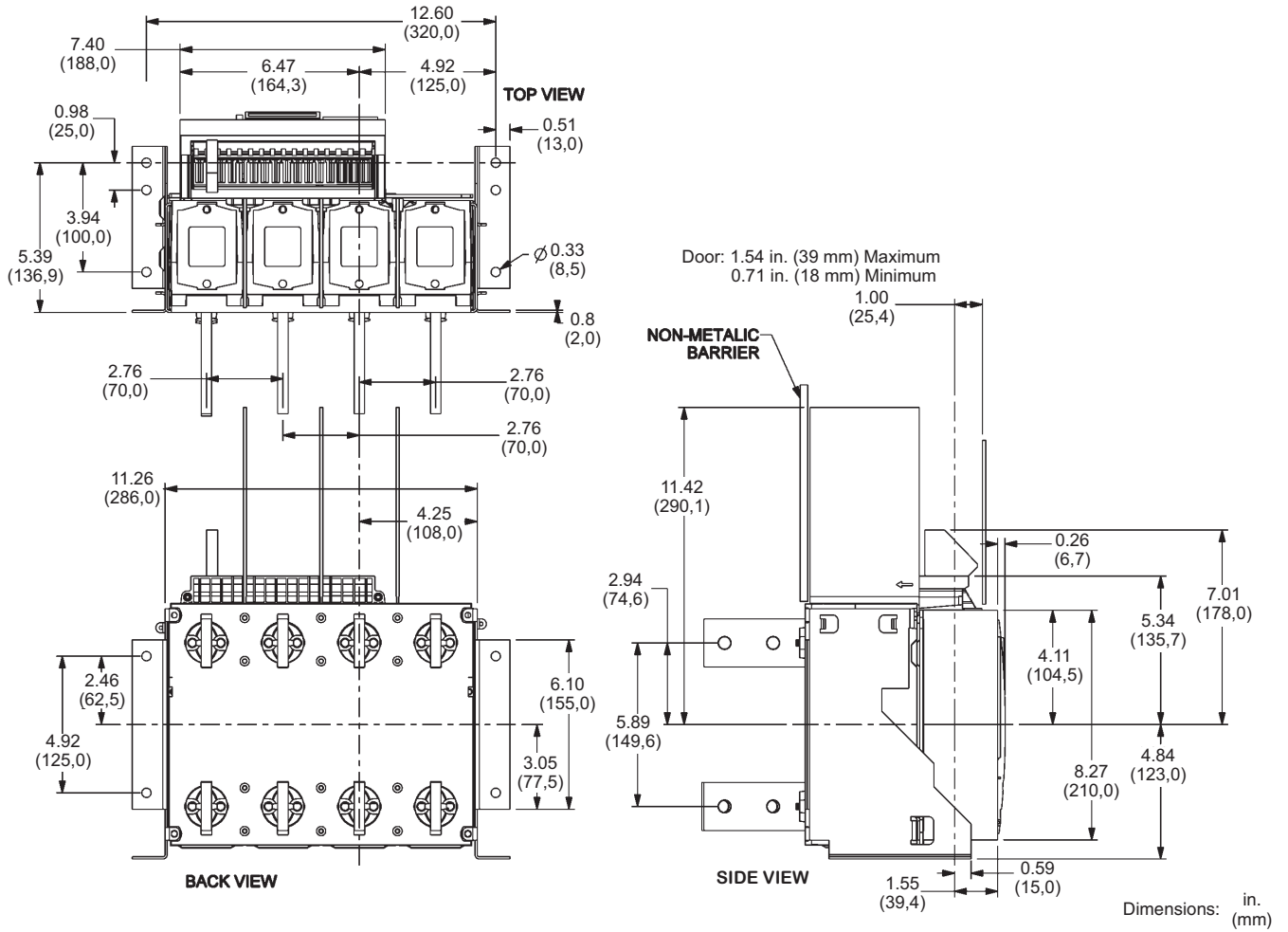

# Masterpact™ NT and NW Universal Power Circuit Breakers

## Masterpact NT Dimensional Drawings

**Figure 66: 800–1600 A Masterpact NT IEC Four-Pole Fixed—RCTV Rear-Connected “T” Vertical**

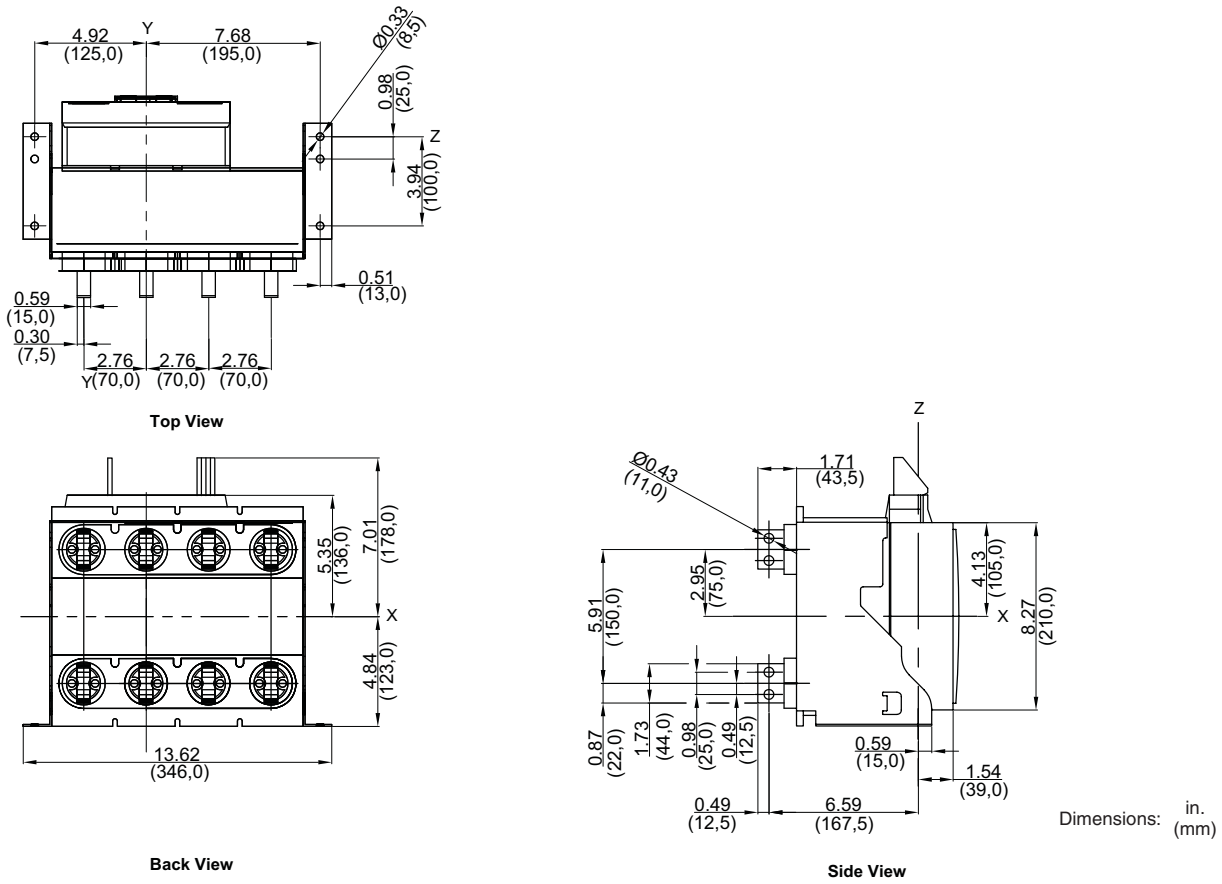

# Masterpact™ NT and NW Universal Power Circuit Breakers

## Masterpact NT Dimensional Drawings

Figure 67: 800–1600 A Masterpact NT IEC Four-Pole Fixed—RCTH Rear-Connected “T” Horizontal

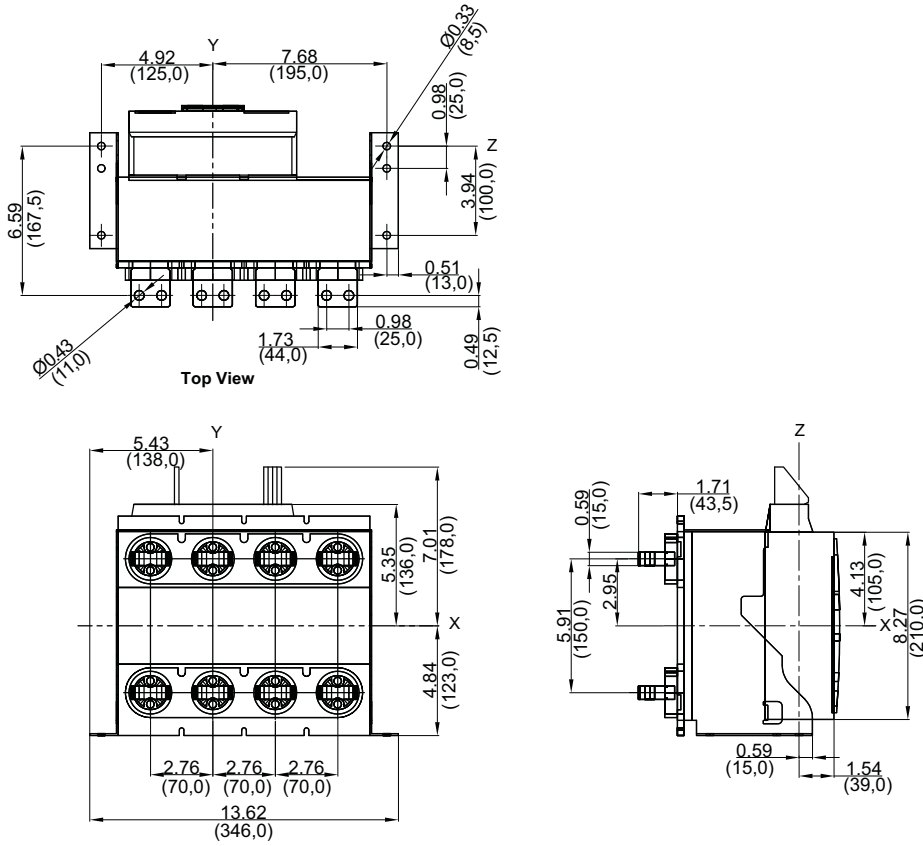

Dimensions: in.  
(mm)



# Masterpact™ NT and NW Universal Power Circuit Breakers

## Masterpact NT Dimensional Drawings

**Figure 68: 800–1600 A Masterpact NT IEC Four-Pole Fixed—FCF Front-Connected Flat**

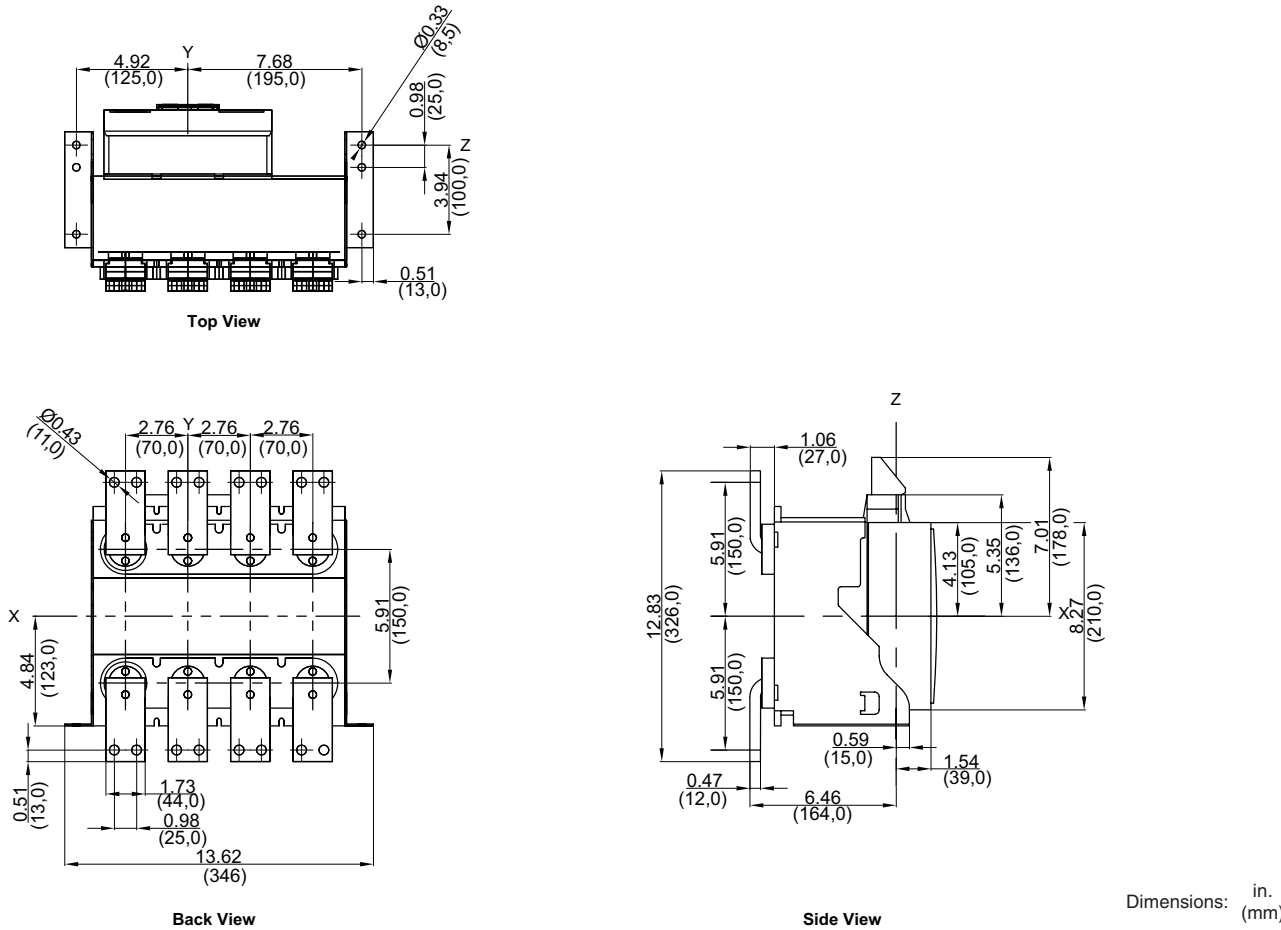

**Figure 69: 800–1200 A Masterpact NT IEC Four-Pole Fixed—Rear Cutout Dimensions**

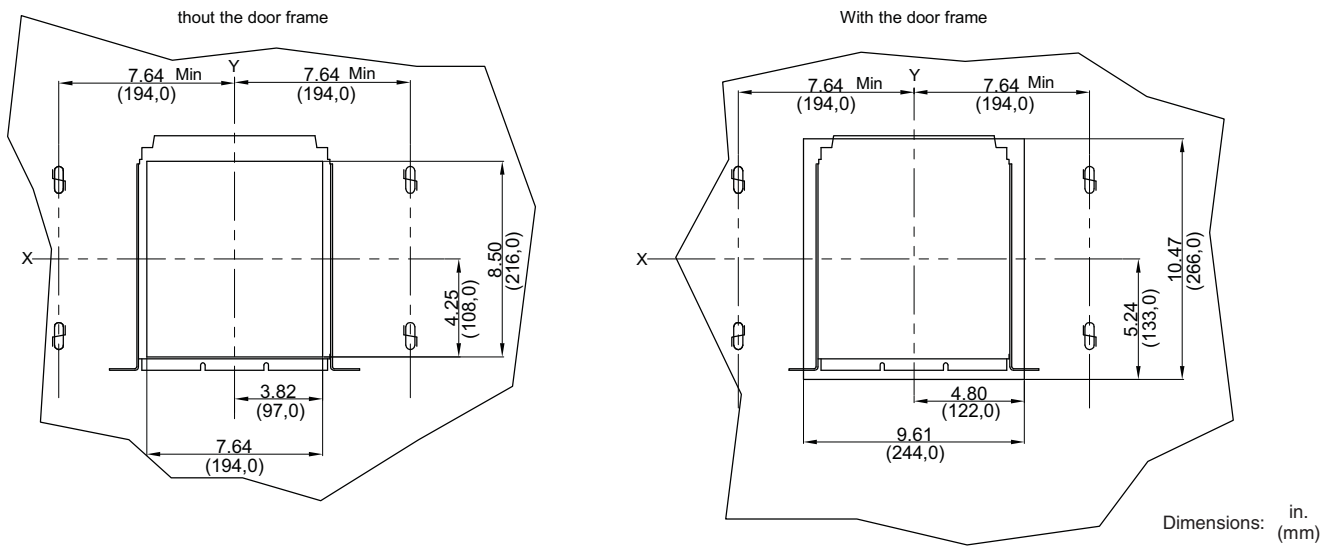

**Masterpact™ NT and NW Universal Power Circuit Breakers**  
**Masterpact NT Dimensional Drawings**

**Neutral Current Transformers**

**Figure 70: 800–1600 A External Neutral Current Transformer**

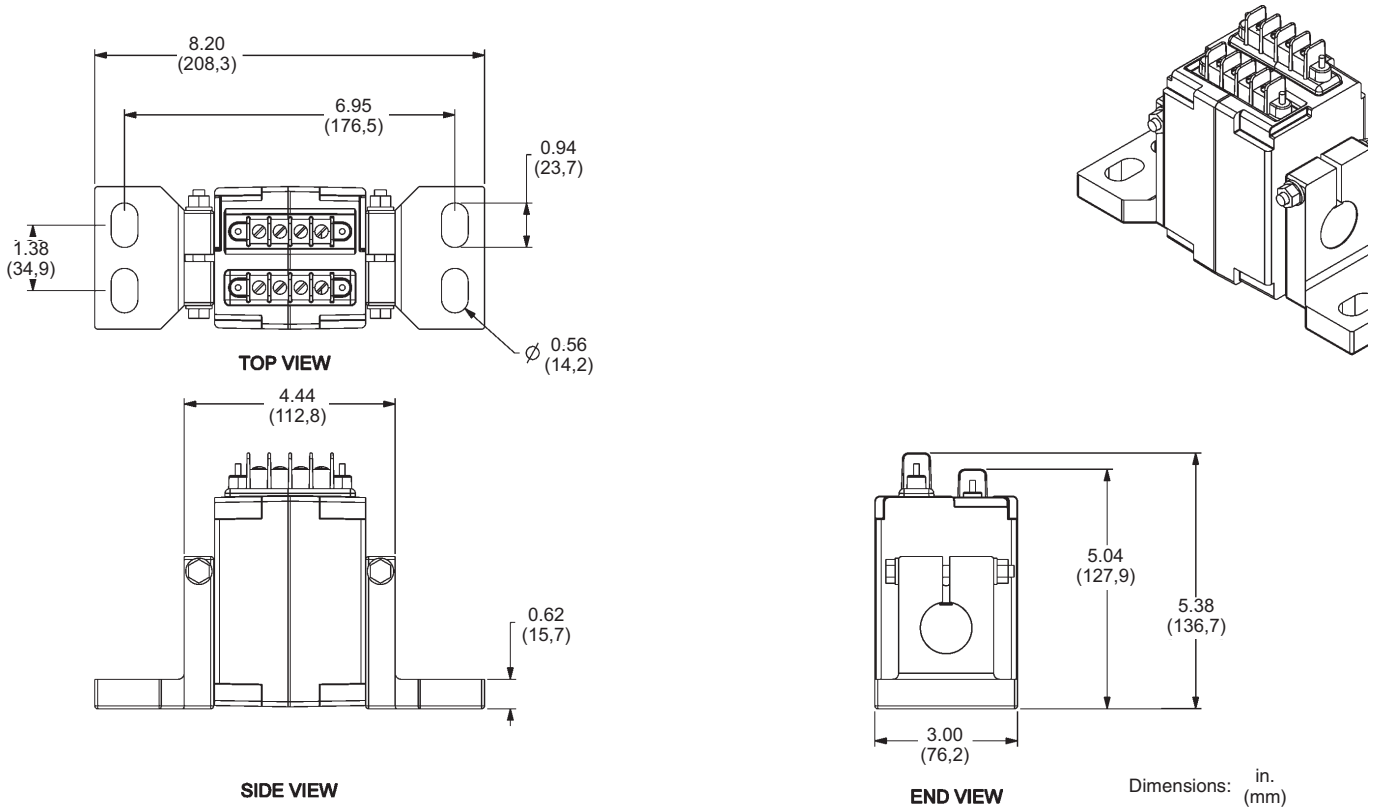

# Masterpact™ NT and NW Universal Power Circuit Breakers

## Masterpact NT Dimensional Drawings

**Figure 71: 800–1600 A External Neutral Current Transformer (Switchboards and Switchgear)**

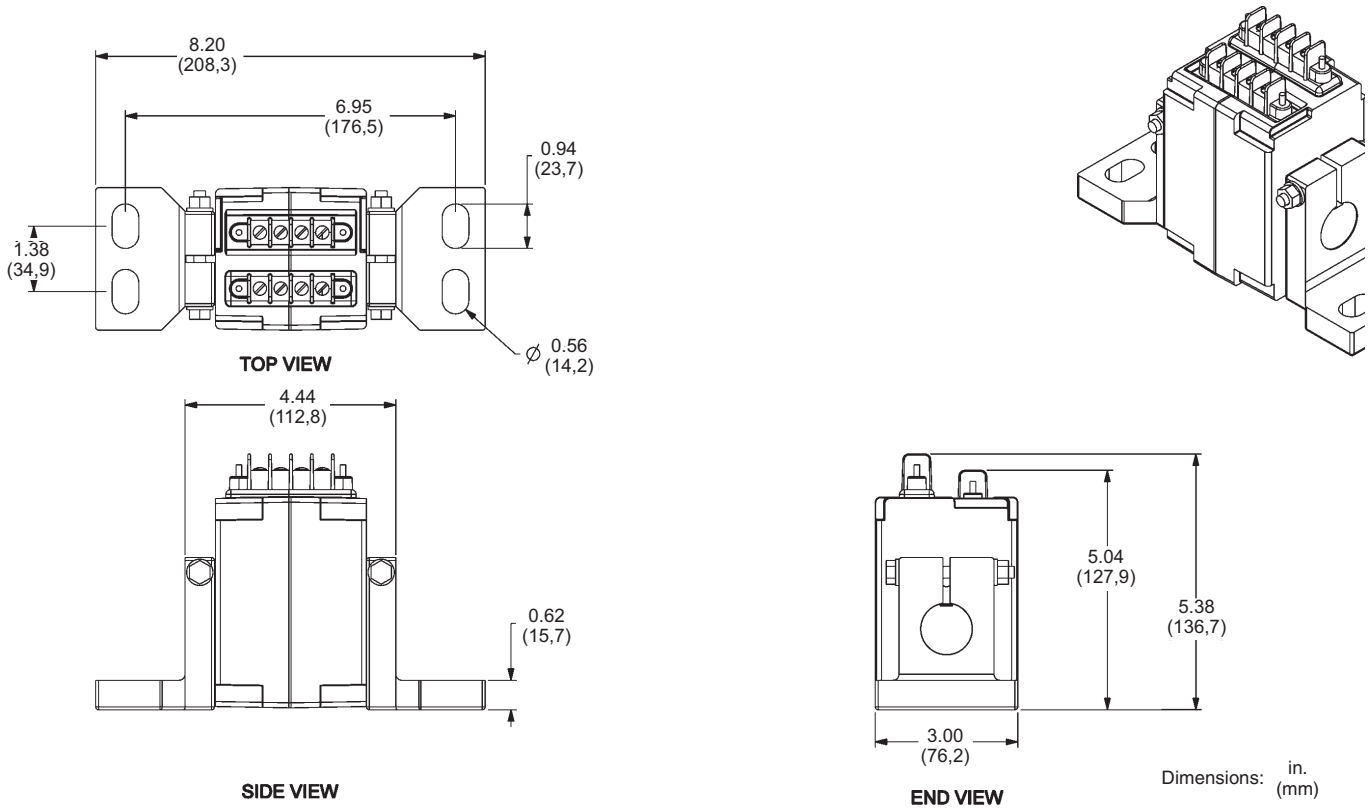

**Figure 72: 800–1600 A External Neutral Current Transformer (Panelboards)**

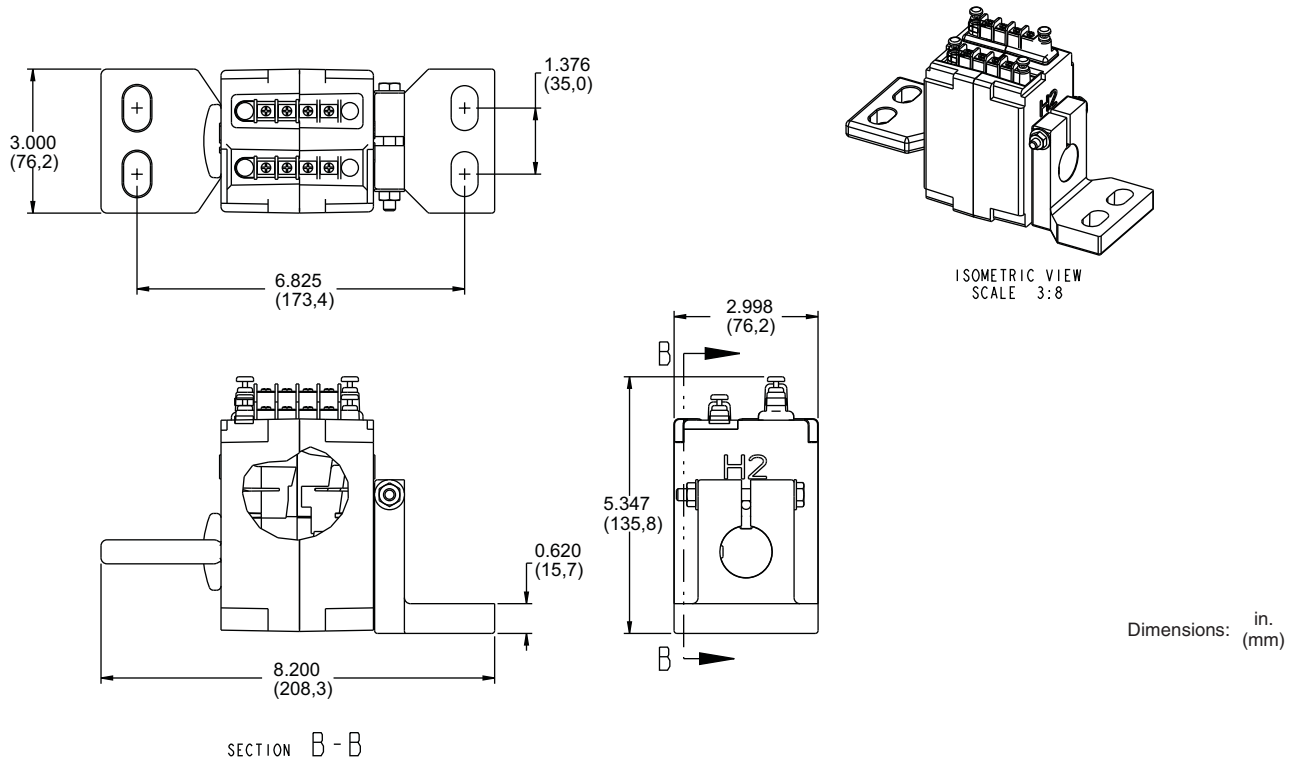

## Section 7—Masterpact NW Dimensional Drawings

Masterpact NW Enclosure Information .....	146
Masterpact NW UL/ANSI Three-Pole Drawout Circuit Breakers .....	146
800–3000 A and 3200 A (H1, H2, H3) Master Drawing .....	146
800–2000 A Rear Connected "T" Vertical (RCTV) .....	147
800–2000 A Rear Connected "T" Horizontal (RCTH) .....	147
800–2000 A Front Connected Flat (FCF) .....	147
800–3000 A Front Connected "T" (FCT) .....	148
2500–3000 A Rear Connected "T" Horizontal (RCTH) .....	148
2000 A L1 & 3200 A Rear Connected Offset Vertical (RCOV) .....	148
2500–3000 A Rear Connected "T" Vertical (RCTV) .....	149
3200 A L1 and 4000–6000 A Master Drawing .....	149
3200 A L1 and 4000–5000 A Rear Connected "T" Vertical (RCTV) .....	150
3200 A L1 and 4000–5000 A Rear Connected "T" Horizontal (RCTH) .....	151
3200 A L1 and 4000 A Front Connected Flat (FCF) .....	152
3200 A L1 and 4000–5000 A Front Connected "T" (FCT) .....	152
6000 A Rear Connected "T" Vertical (RCTV) .....	153
Masterpact NW Drawout Cradle Mounting .....	153
800–3000 A and 3200 A (H1, H2, H3) Door Cutout .....	154
3200 A L1 and 4000–6000 A Door Cutout .....	154
Door Escutcheon Hole Pattern .....	155
Masterpact NW UL/ANSI Three-Pole Fixed Circuit Breakers .....	156
800–3000 A and 3200 A Master Drawing .....	156
800–2000 A Rear Connected "T" Vertical (RCTV) .....	156
800–2000 A Rear Connected "T" Horizontal (RCTH) .....	157
800–2000 A Front Connected Flat (FCF) .....	157
800–3000 A Front Connected "T" (FCT) .....	158
2500–3000 A Rear Vertical "T" Horizontal (RCTV) .....	158
2500–3000 A Rear Connected "T" Horizontal (RCTH) .....	159
2000 L1 and 3200 A Rear Connected Offset Vertical (RCOV) .....	159
4000 A (W-Frame) Rear Connected Offset Vertical (RCOV) .....	160
4000–6000 A Master Drawing .....	160
4000–5000 A Rear Connected "T" Vertical (RCTV) .....	161
4000–5000 A Rear Connected "T" Horizontal (RCTH) .....	161
6000 A Rear Connected "T" Vertical (RCTV) .....	162
800–3200 A Door Cutout .....	162
4000–6000 A Door Cutout .....	163
Masterpact NW UL and ANSI Four-Pole Drawout Circuit Breakers .....	163
800–3000 A and 3200 A Master Drawing .....	163
800–2000 A Rear Connected "T" Vertical (RCTV) .....	164
800–2000 A Rear Connected "T" Horizontal (RCTH) .....	164
800–2000 A Front Connected Flat (FCF) .....	165
800–3000 A Front Connected "T" (FCT) .....	165
2500–3000 A Rear Connected "T" Vertical (RCTV) .....	166
2500–3000 A Rear Connected "T" Horizontal (RCTH) .....	166
2000 A L1 and 3200 A Rear Connected Offset Vertical (RCOV) .....	167
3200 A L1 and 4000–6000 A Master Drawing .....	168
3200 A L1 and 4000–5000 A Rear Connected "T" Vertical (RCTV) .....	169
3200 A L1 and 4000–5000 A Rear Connected "T" Horizontal (RCTH) .....	170
3200 A L1 and 4000 A Front Connected Flat (FCF) .....	171
3200 A L1 and 4000–5000 A Front Connected "T" (FCT) .....	172
6000 A Rear Connected "T" Vertical (RCTV) .....	173

# Masterpact™ NT and NW Universal Power Circuit Breakers

## Masterpact NW Dimensional Drawings

Masterpact NW UL and ANSI Four-Pole Fixed Circuit Breakers .....	174
800–3000 A and 3200 A Master Drawing .....	174
800–2000 A Rear Connected "T" Vertical (RCTV) .....	174
800–2000 A Rear Connected "T" Horizontal (RCTH) .....	175
800–2000 A Front Connected Flat (FCF) .....	175
800–3000 A Front Connected "T" (FCT) .....	176
2000 A L1 and 3200 A Rear Connected Offset Vertical (RCOV) .....	177
2500–3000 A Rear Vertical "T" Horizontal (RCTV) .....	178
2500–3000 A Rear Connected "T" Horizontal (RCTH) .....	178
4000–6000 A Master Drawing .....	179
4000–5000 A Rear Connected "T" Vertical (RCTV) .....	180
4000–5000 A Rear Connected "T" Horizontal (RCTH) .....	181
6000 A Rear Connected "T" Vertical (RCTV) .....	182
Pan Drawings for Three-Pole and Four-Pole Circuit Breakers.....	183
Masterpact NW Neutral Current Transformers .....	183
Neutral Current Transformer 100–250 A, 400–2000 A .....	183
Neutral Current Transformer 2000–4000 A .....	184
Double Neutral Current Transformer 2000–6300 A .....	184
MDGF/SGR Current Transformer .....	185
Masterpact NW IEC Three-Pole Drawout Circuit Breakers .....	186
800–3200 A Rear Connected "T" Vertical (RCTV) .....	186
800–3200 A Rear Connected "T" Horizontal (RCTH) .....	186
800–3200 A Front Connected Flat (FCF) .....	186
4000 A Rear Connected "T" Vertical (RCTV) .....	187
4000 A Rear Connected "T" Horizontal (RCTH) .....	187
5000 A Rear Connected "T" Vertical (RCTV) .....	188
5000 A Rear Connected "T" Horizontal (RCTH) .....	189
6300 A Rear Connected "T" Vertical (RCTV) .....	190
Masterpact NW IEC Three-Pole Fixed Circuit Breakers .....	191
800–3200 A Rear Connected "T" Vertical (RCTV) .....	191
800–3200 A Rear Connected "T" Horizontal (RCTH) .....	191
800–3200 A Front Connected Flat (FCF) .....	191
4000 A Rear Connected "T" Vertical (RCTV) .....	192
4000 A Rear Connected "T" Horizontal (RCTH) .....	192
5000 A Rear Connected "T" Vertical (RCTV) .....	193
5000 A Rear Connected "T" Horizontal (RCTH) .....	194
6300 A Rear Connected "T" Vertical (RCTV) .....	195
Masterpact NW IEC Four-Pole Drawout Circuit Breakers .....	195
800–3200 A Rear Connected "T" Vertical (RCTV) .....	195
800–3200 A Rear Connected "T" Horizontal (RCTH) .....	196
800–3200 A Front Connected Flat (FCF) .....	196
4000 A Rear Connected "T" Vertical (RCTV) .....	196
4000 A Rear Connected "T" Horizontal (RCTH) .....	197
5000 A Rear Connected "T" Vertical (RCTV) .....	198
5000 A Rear Connected "T" Horizontal (RCTH) .....	199
6300 A Rear Connected "T" Vertical (RCTV) .....	200
Masterpact NW IEC Four-Pole Fixed Circuit Breakers .....	200
800–3200 A Rear Connected "T" Vertical (RCTV) .....	200
800–3200 A Rear Connected "T" Horizontal (RCTH) .....	201
800–3200 A Front Connected Flat (FCF) .....	201
4000 A Rear Connected "T" Vertical (RCTV) .....	201
4000 A Rear Connected "T" Horizontal (RCTH) .....	202
5000 A Rear Connected "T" Vertical (RCTV) .....	202
5000 A Rear Connected "T" Horizontal (RCTH) .....	203
6300 Rear Connected "T" Vertical (RCTV) .....	204

# Masterpact™ NT and NW Universal Power Circuit Breakers

## Masterpact NW Dimensional Drawings

### Enclosure Information

Table 68: Minimum Enclosure Information

Number of Poles	Circuit Breaker Rating	Circuit Breaker Enclosure Dimensions		Ventilation Area					
		(H x W x D)		Top		Bottom		Front Face	
		in.	mm	in. <sup>2</sup>	mm <sup>2</sup>	in. <sup>2</sup>	mm <sup>2</sup>	in. <sup>2</sup>	mm <sup>2</sup>
3P	2000 A and below, UL 1066 (ANSI C37.50)	21.25 x 21.75 x 15.75	539.8 x 552.5 x 400	59.62	38 460	35.62	22 980	—	—
	3000 A and below, UL 489	18.37 x 24.00 x 15.75	466.6 x 609.6 x 400	16.62	10 720	16.62	10 720	—	—
	3200 A, and 4000 A (W-Frame) UL 1066 (ANSI C37.50)	31.00 x 21.75 x 15.75	787.4 x 552.5 x 400	59.62	38 460	—	—	93.6	60 390
	4000–5000 A, UL 1066 (ANSI C37.50)	33.00 x 32.62 x 15.75	838.2 x 828.5 x 400	198.75	128 230	—	—	130.5	84 190
	4000–6000 A, UL 489	21.75 x 36.00 x 15.75	552.5 x 914.4 x 400	16.62	10 720	16.62	10 720	—	—
4P	2000 A and below, UL 1066 (ANSI C37.50)	21.25 x 26.28 x 15.75	539.8 x 667.5 x 400	59.62	38 460	35.62	22 980	—	—
	3000 A and below, UL 489	18.37 x 30.00 x 15.75	466.6 x 762.0 x 400	16.62	10 720	16.62	10 720	—	—
	3200 A, and 4000 A (W-Frame) UL 1066 (ANSI C37.50)	31.00 x 26.28 x 15.75	787.4 x 667.5 x 400	59.62	38 460	—	—	93.6	60 390
	4000–5000 A, UL 1066 (ANSI C37.50)	33.00 x 41.68 x 15.75	838.2 x 1058.7 x 400	198.75	128 230	—	—	130.5	84 190
	4000–6000 A, UL 489	21.75 x 45.00 x 15.75	552.5 x 1168.4 x 400	16.62	10 720	16.62	10 720	—	—

### UL®/ANSI Three-Pole Drawout Circuit Breakers

Figure 73: 800–3000 A and 4000 A (H1, H2, H3) Master Drawing

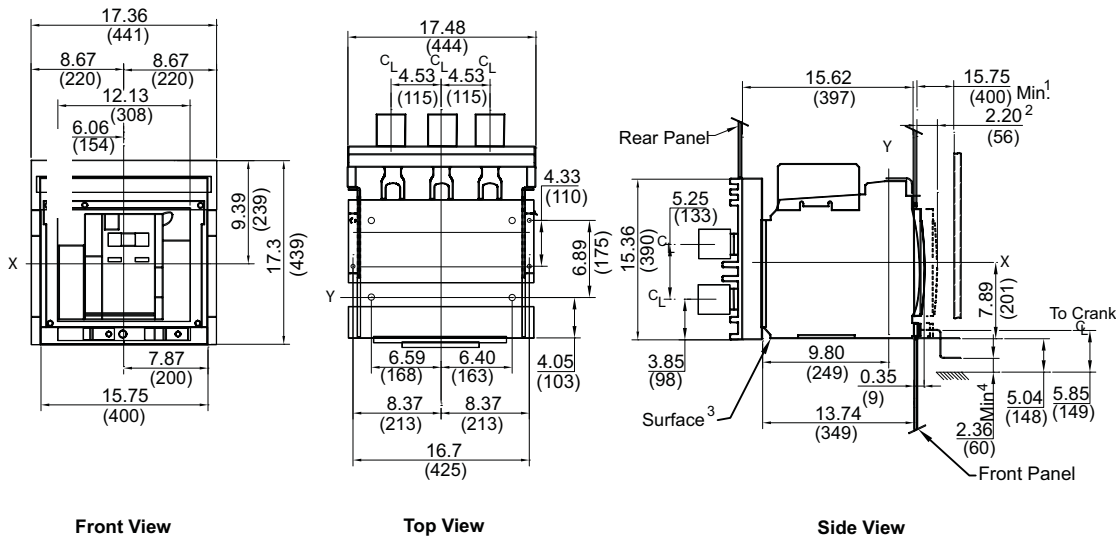

1. Minimum to withdraw circuit breaker.
2. Distance to drawout position.
3. Circuit breaker mounting surface.
4. Minimum for circuit breaker racking handle.

Dimensions: in.  
(mm)

# Masterpact™ NT and NW Universal Power Circuit Breakers

## Masterpact NW Dimensional Drawings

**Figure 74: 800–2000 A Rear-Connected "T" Vertical (RCTV)**

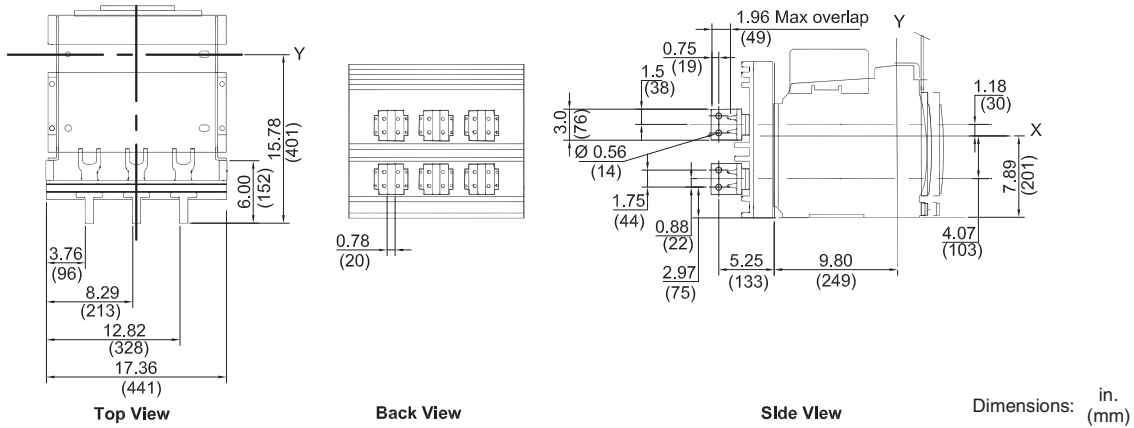

**Figure 75: 800–2000 A Rear-Connected "T" Horizontal (RCTH)**

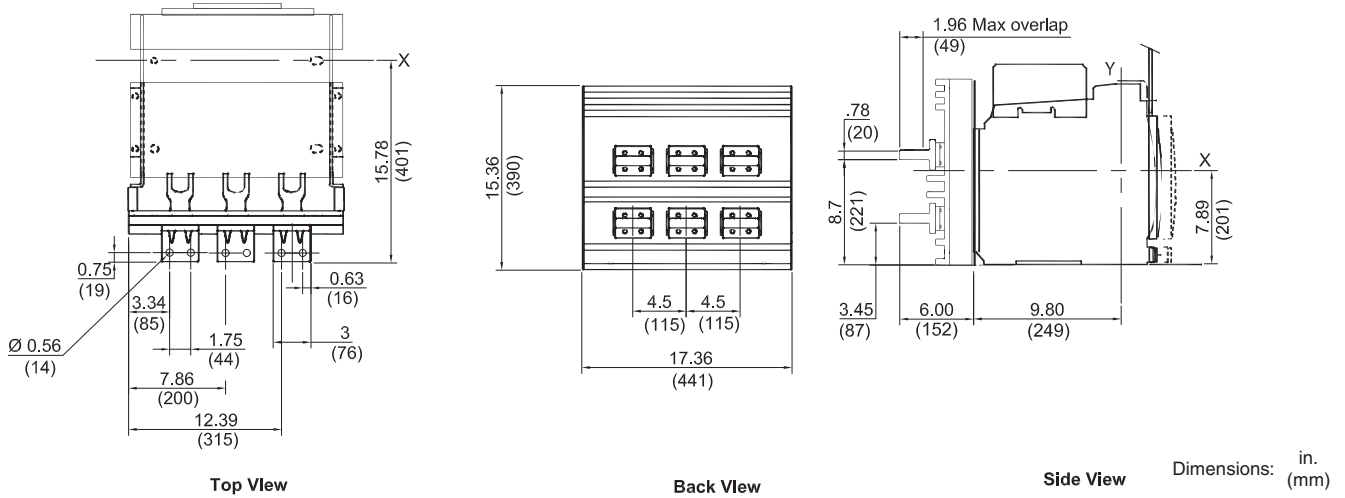

**Figure 76: 800–2000 A Front-Connected Flat (FCF)**

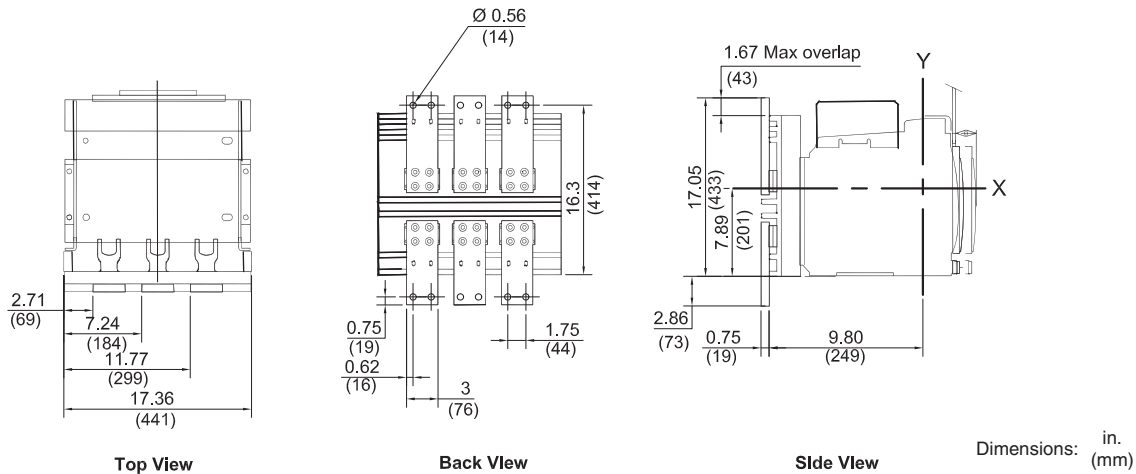

# Masterpact™ NT and NW Universal Power Circuit Breakers

## Masterpact NW Dimensional Drawings

Figure 77: 800–3000 A Front-Connected "T" (FCT)

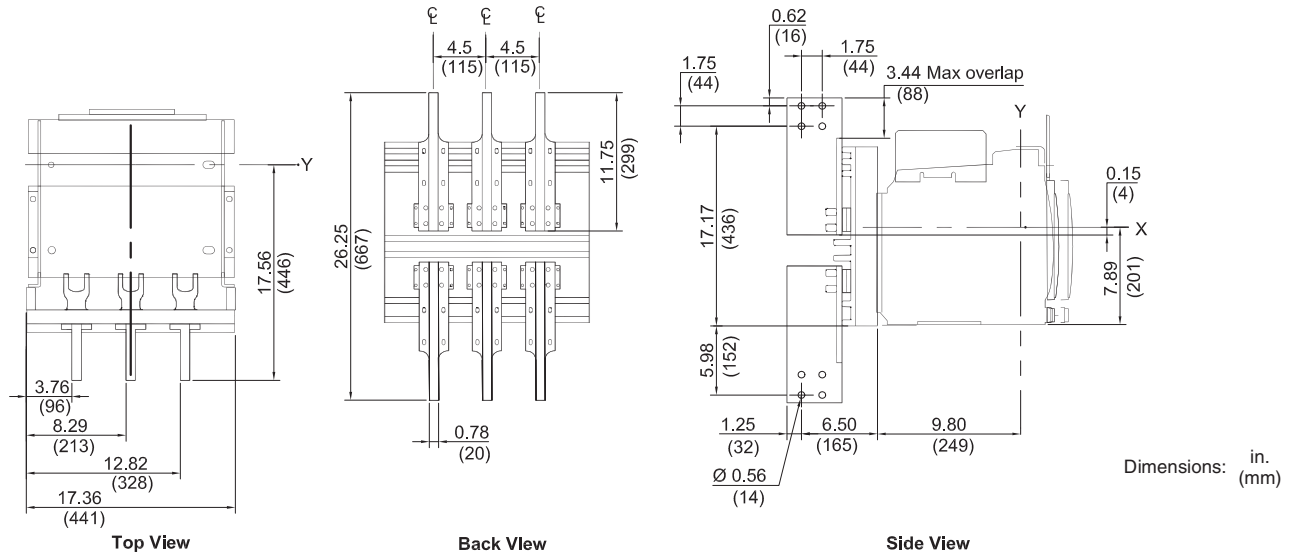

Figure 78: 2500–3000 A Rear-Connected "T" Horizontal (RCH)

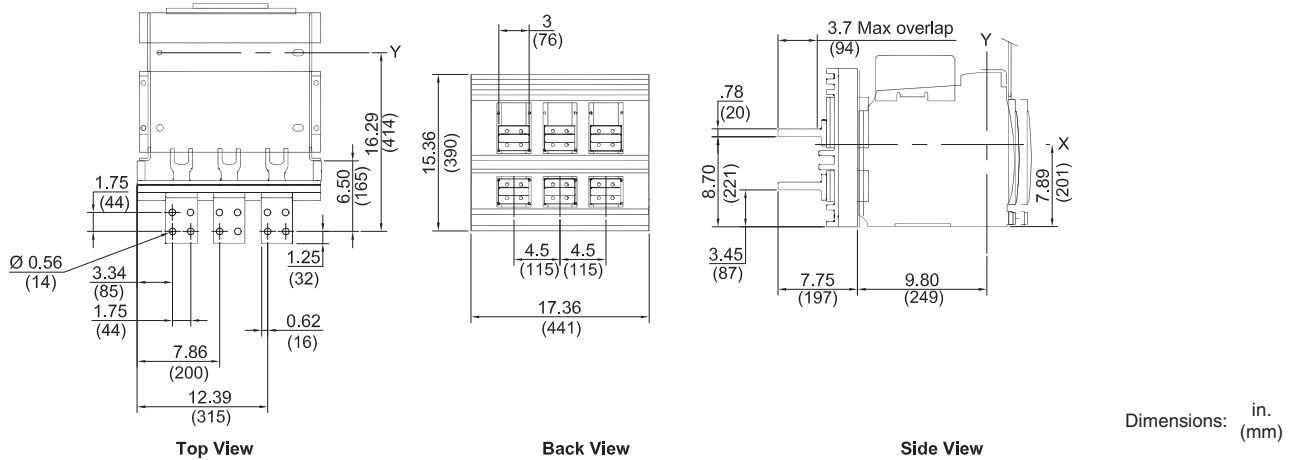
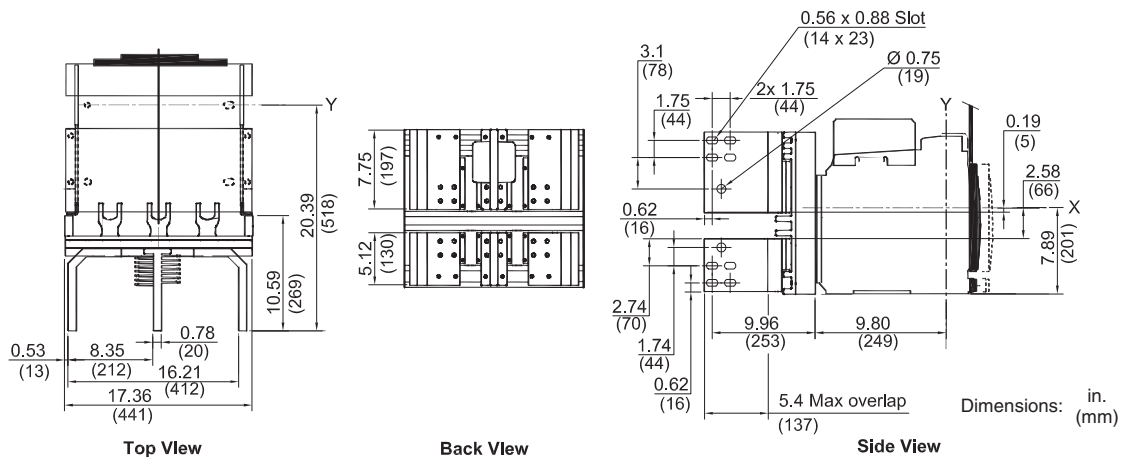

Figure 79: 2000 A L1 and 3200 A Rear-Connected Offset Vertical (RCOV)





# Masterpact™ NT and NW Universal Power Circuit Breakers

## Masterpact NW Dimensional Drawings

**Figure 80: 2500–3000 A Rear-Connected "T" Vertical (RCTV)**

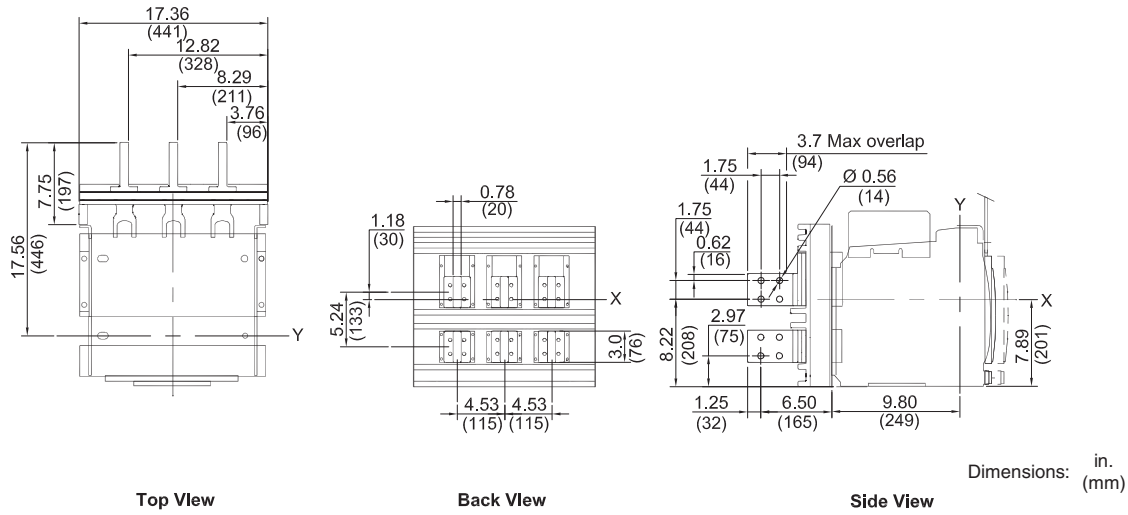

**Figure 81: 3200 A L1 and 4000–6000 A Master Drawing**

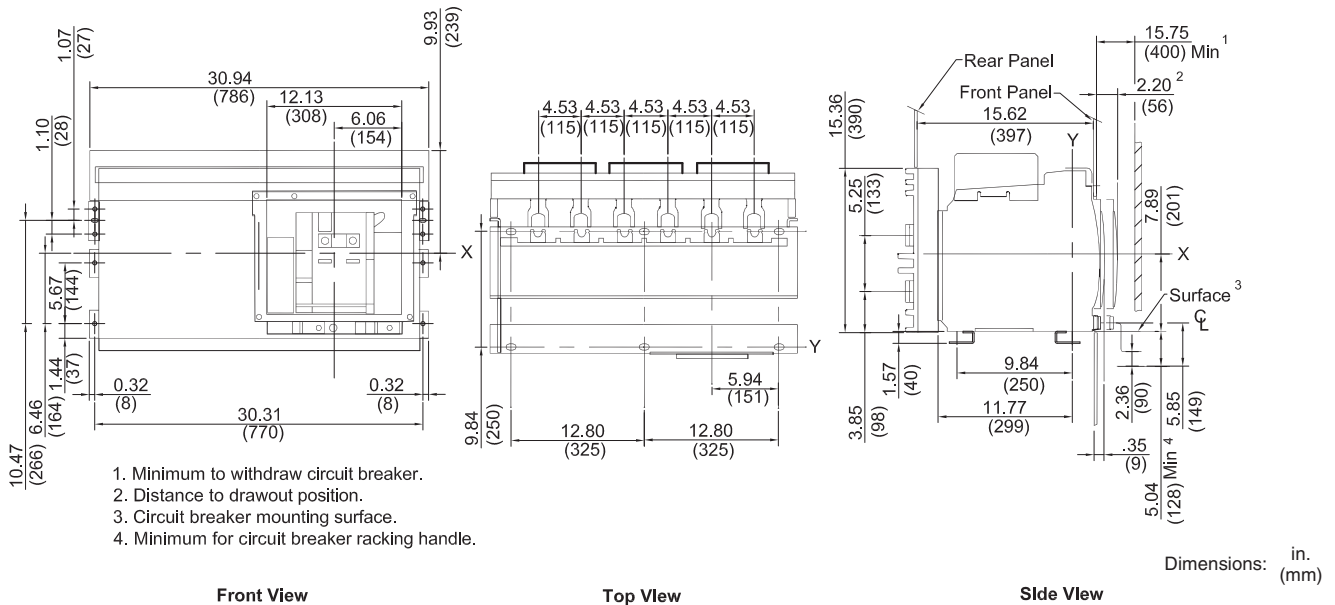

# Masterpact™ NT and NW Universal Power Circuit Breakers

## Masterpact NW Dimensional Drawings

Figure 82: 3200 A L1 and 4000–5000 A Rear-Connected "T" Vertical (RCTV)

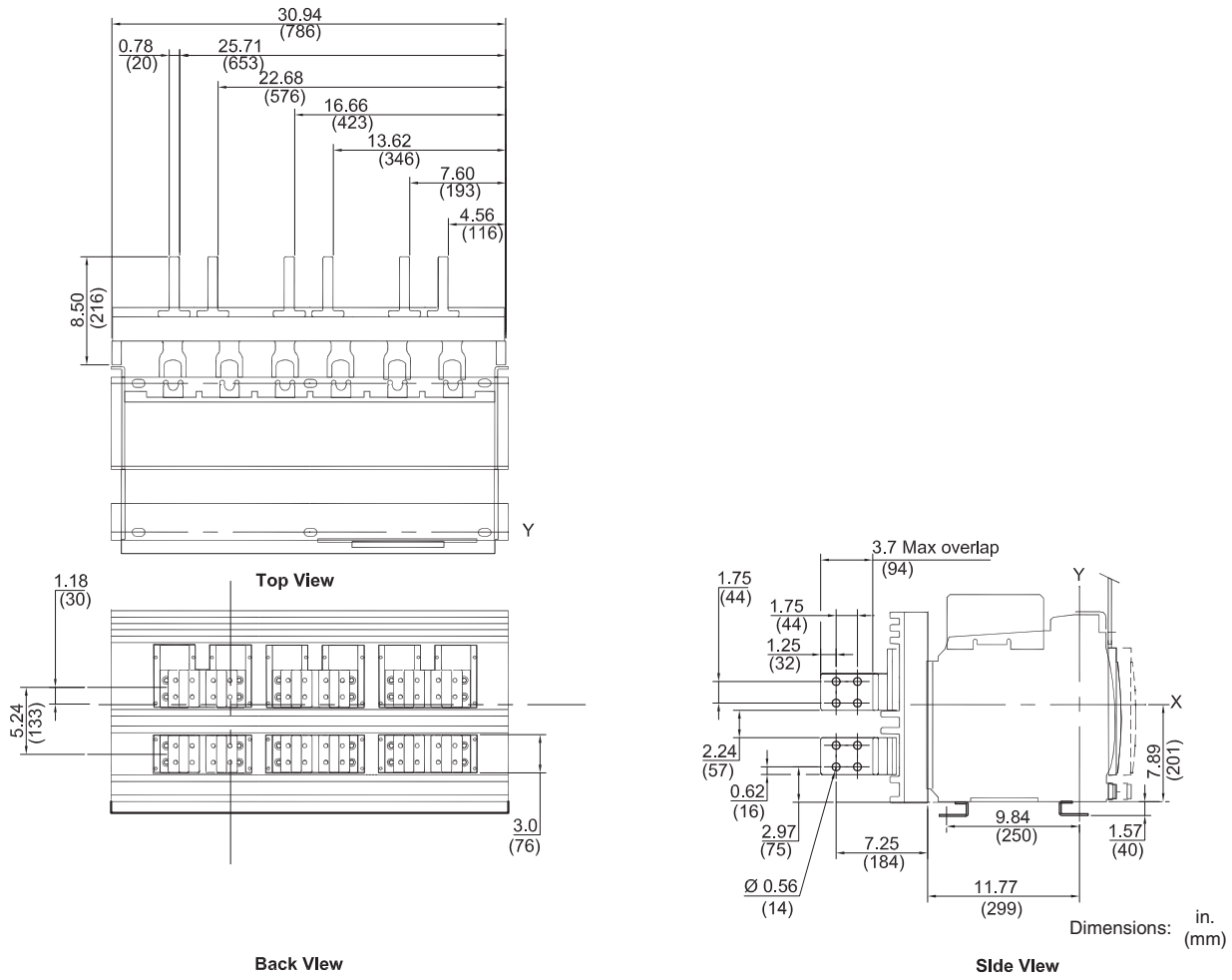

# Masterpact™ NT and NW Universal Power Circuit Breakers

## Masterpact NW Dimensional Drawings

**Figure 83: 3200 A L1 and 4000–5000 A Rear-Connected "T" Horizontal (RCH)**

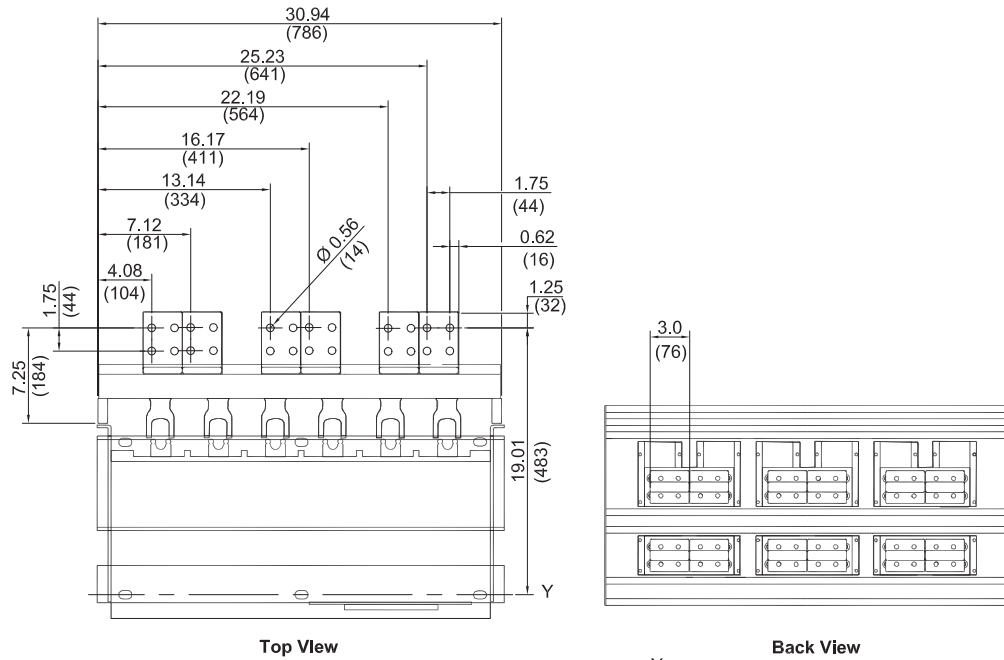

**Top View**

**Back View**

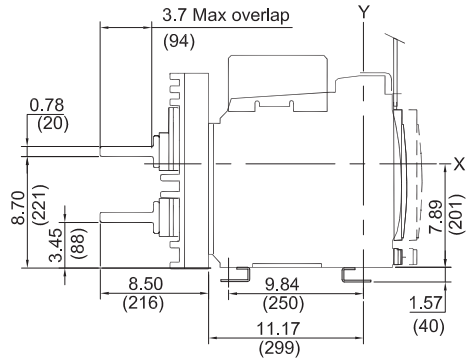

Dimensions: in.  
(mm)

# Masterpact™ NT and NW Universal Power Circuit Breakers

## Masterpact NW Dimensional Drawings

Figure 84: 3200 A L1 and 4000 A Front-Connected Flat (FCF)

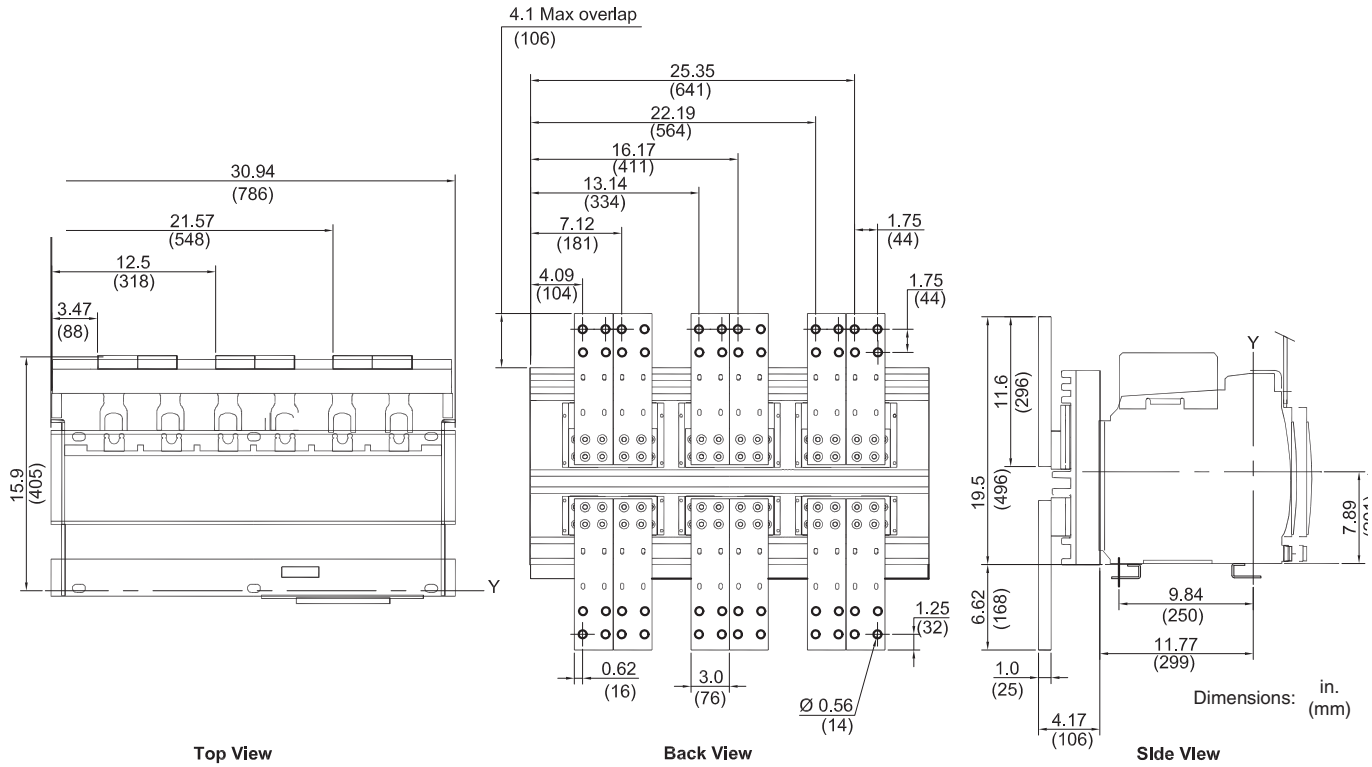
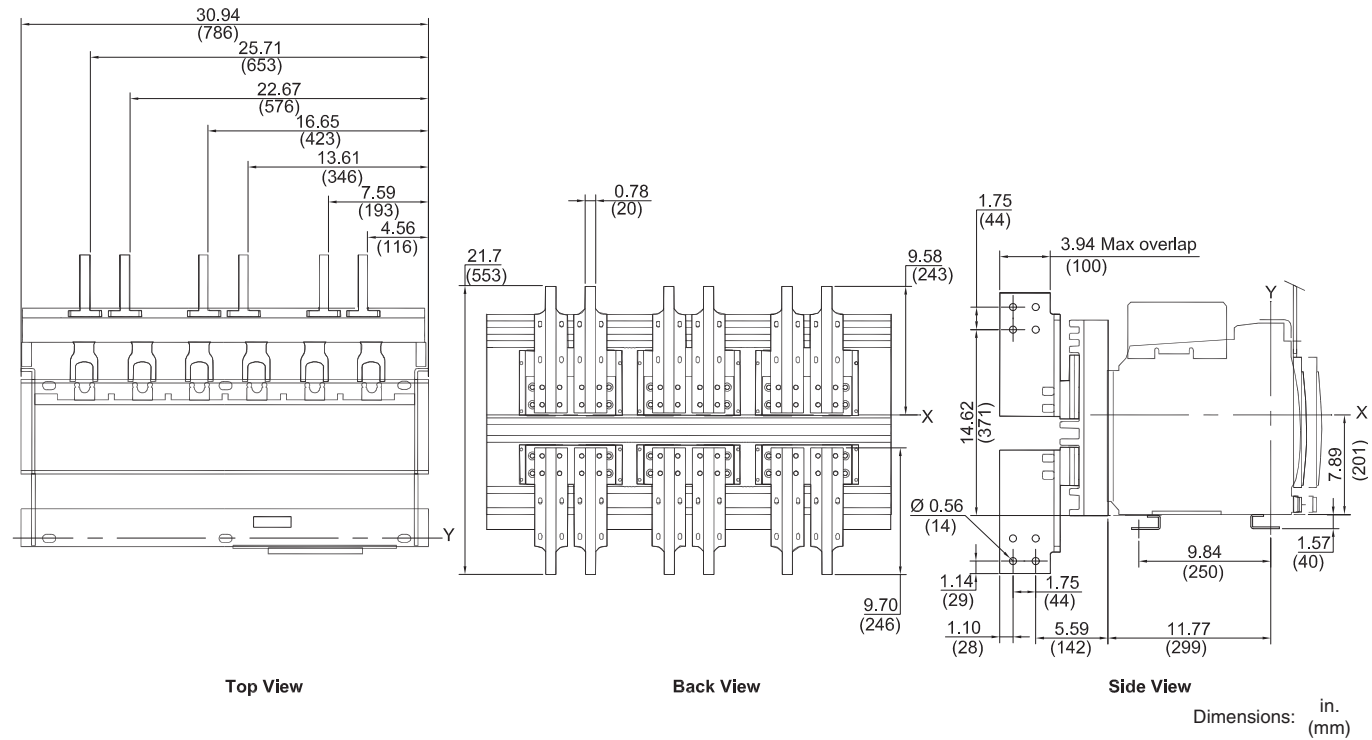

Figure 85: 3200 A L1 and 4000-5000 A Front-Connected "T" (FCT)



# Masterpact™ NT and NW Universal Power Circuit Breakers

## Masterpact NW Dimensional Drawings

**Figure 86: 6000 A Rear-Connected "T" Vertical (RCTV)**

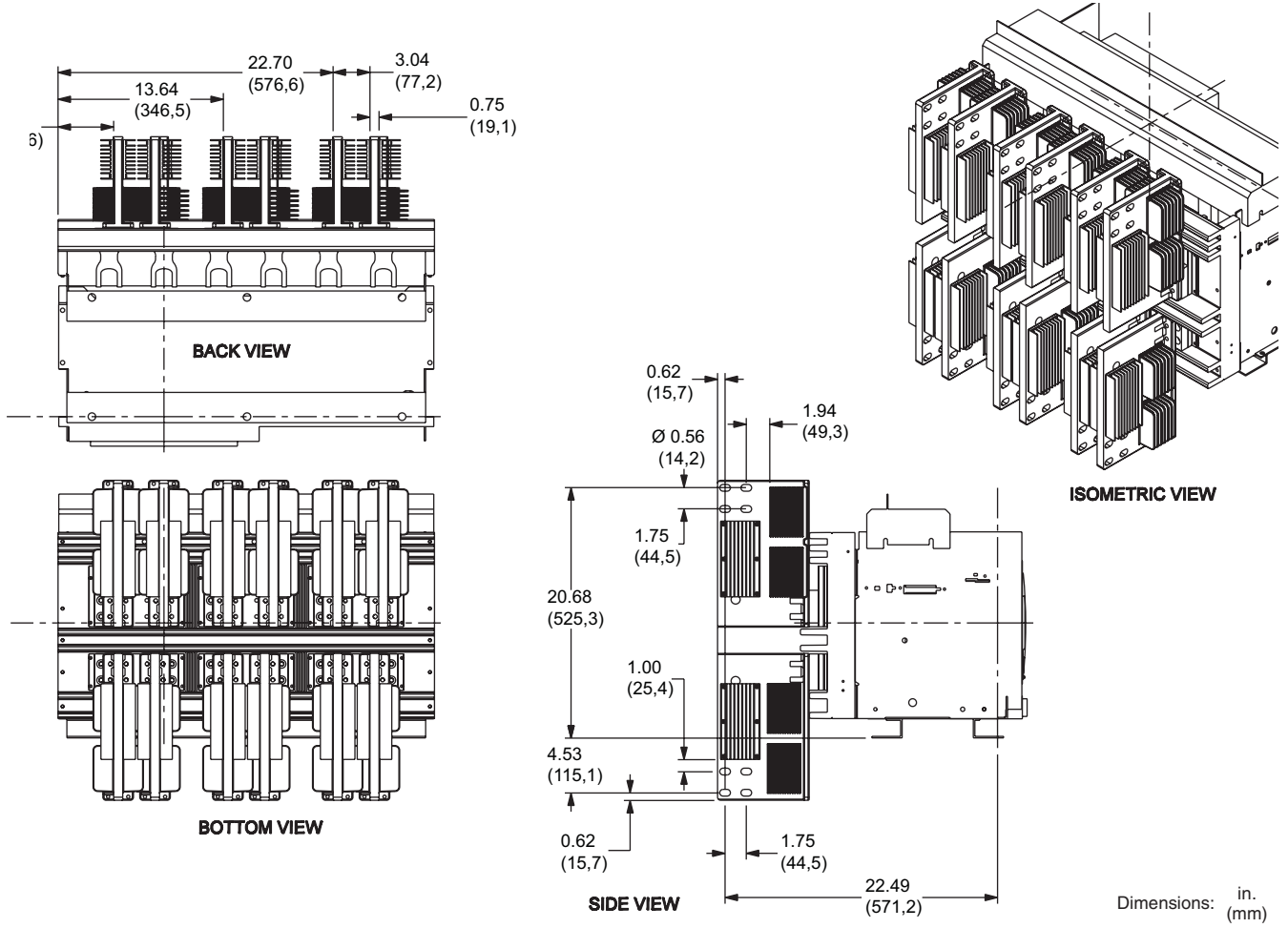

**Figure 87: Drawout Cradle Mounting**

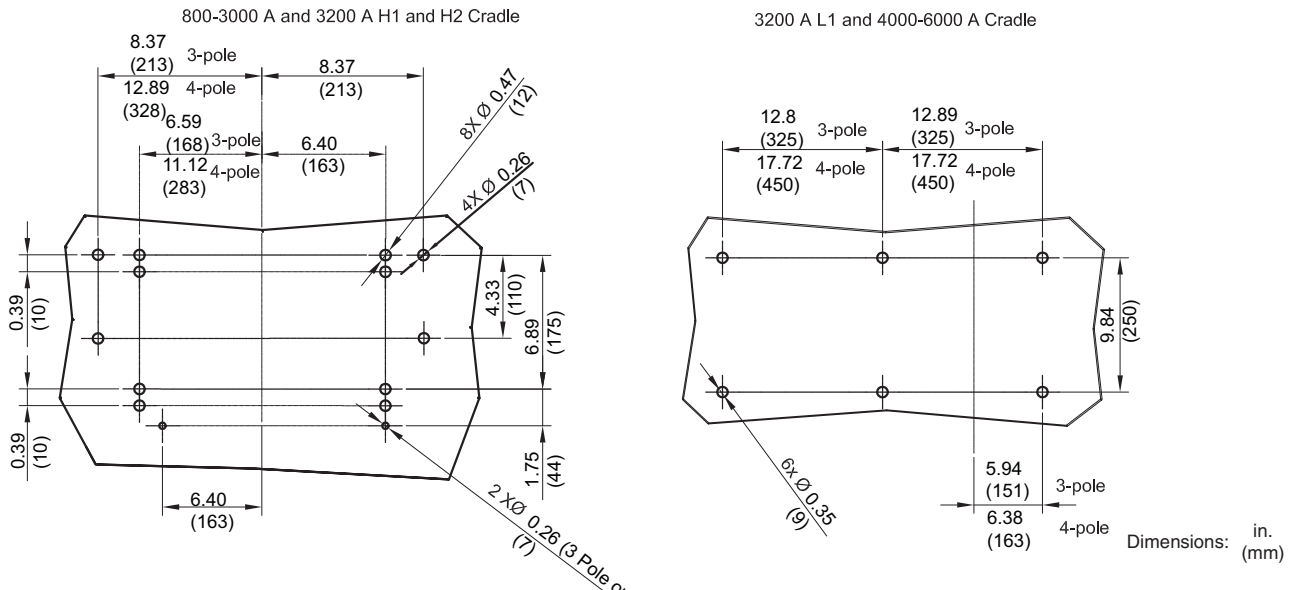

# Masterpact™ NT and NW Universal Power Circuit Breakers

## Masterpact NW Dimensional Drawings

Figure 88: 800–3000 A and 3200 A (H1, H2, H3) Door Cutout

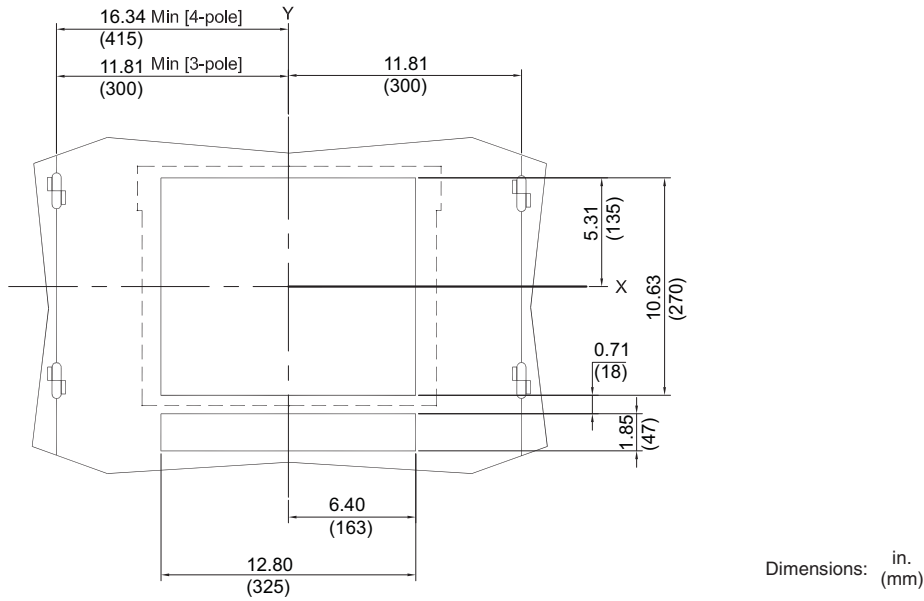
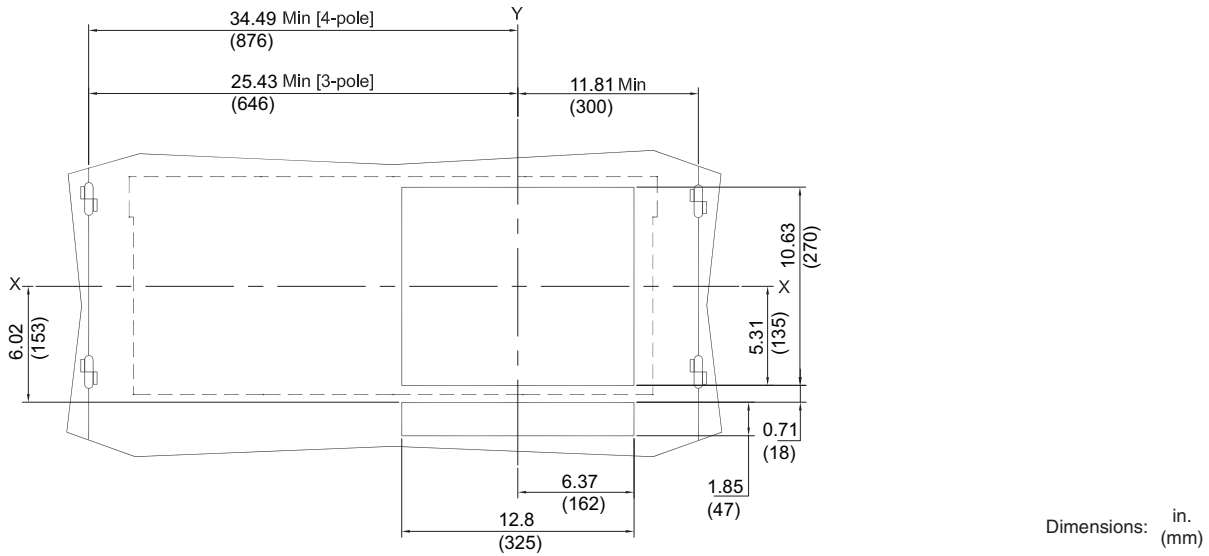

Figure 89: 3200 A L1 and 4000–6000 A Door Cutout



# Masterpact™ NT and NW Universal Power Circuit Breakers

## Masterpact NW Dimensional Drawings

**Figure 90: Door Escutcheon Hole Pattern**

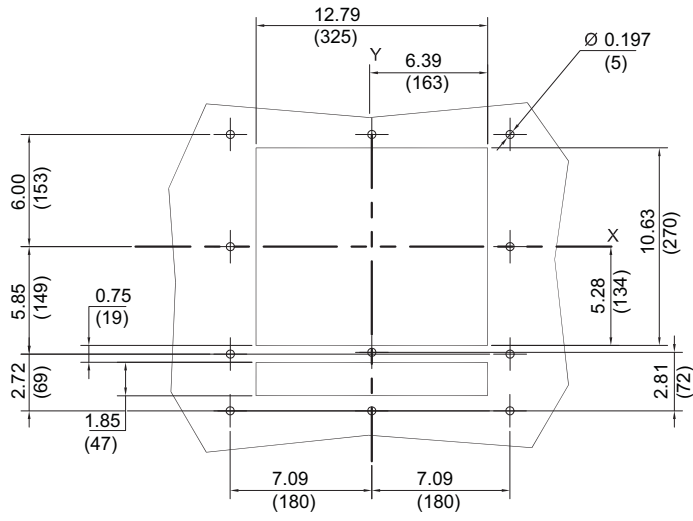

Dimensions: in.  
(mm)

**Masterpact™ NT and NW Universal Power Circuit Breakers**  
**Masterpact NW Dimensional Drawings**

**UL/ANSI Three-Pole Fixed Circuit Breakers**

**Figure 91: 800–3000 A, 3200 A and 4000 A (W-Frame) Master Drawing**

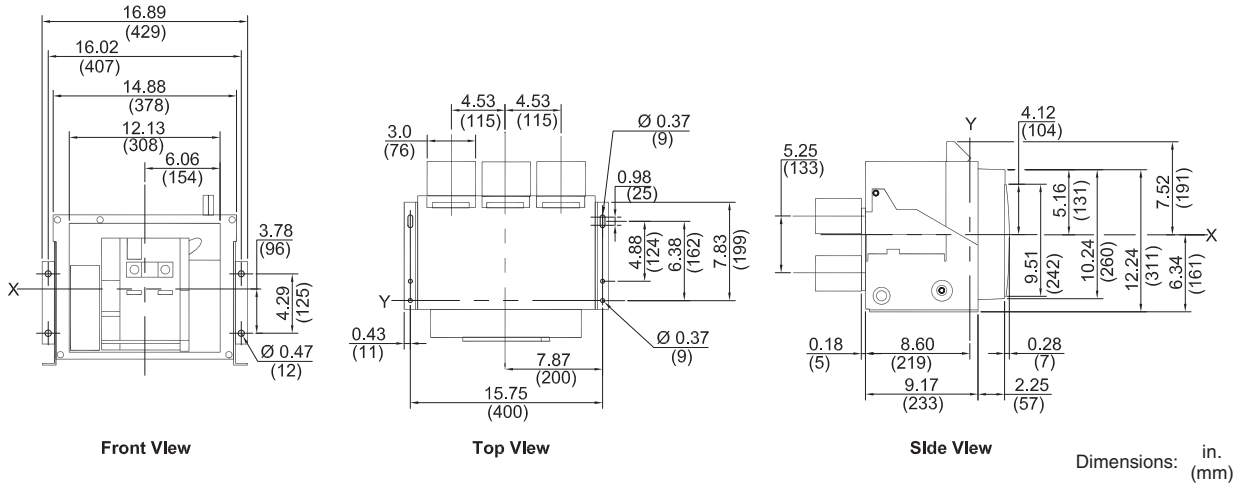

**Figure 92: 800–2000 A Rear-Connected "T" Vertical (RCTV)**

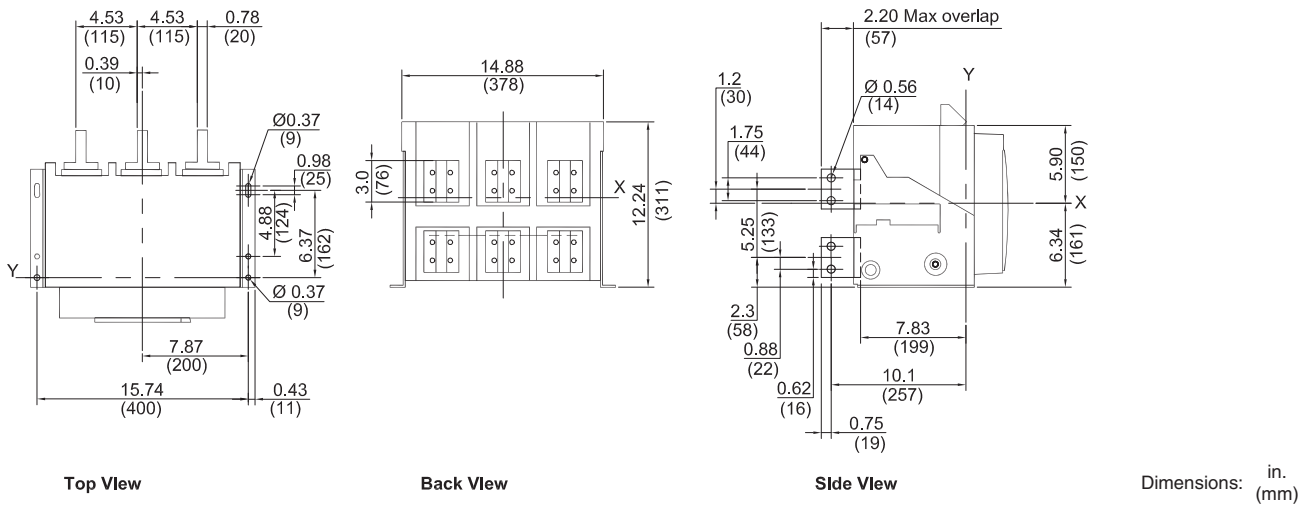



# Masterpact™ NT and NW Universal Power Circuit Breakers

## Masterpact NW Dimensional Drawings

**Figure 93: 800–2000 A Rear-Connected "T" Horizontal (RCTH)**

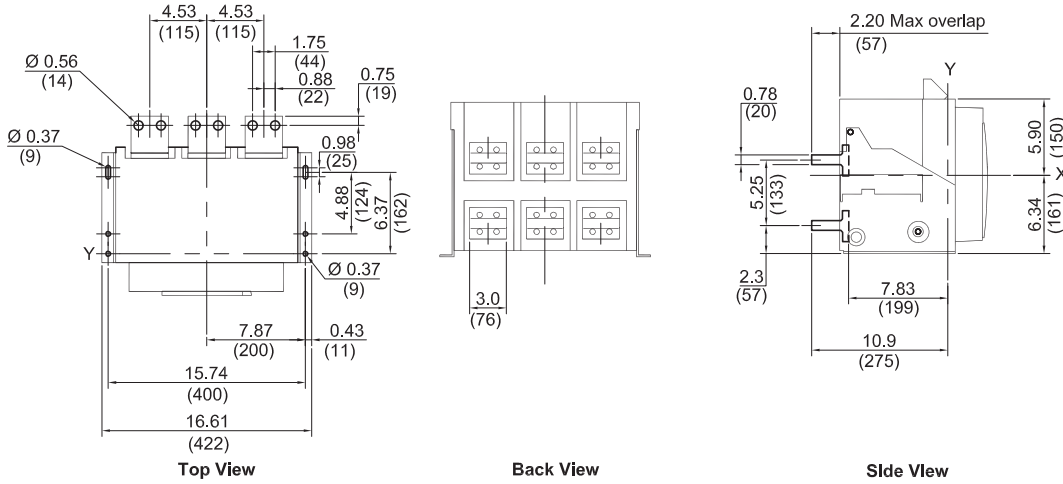

Dimensions: in.  
(mm)

**Figure 94: 800–2000 A Front-Connected Flat (FCF)**

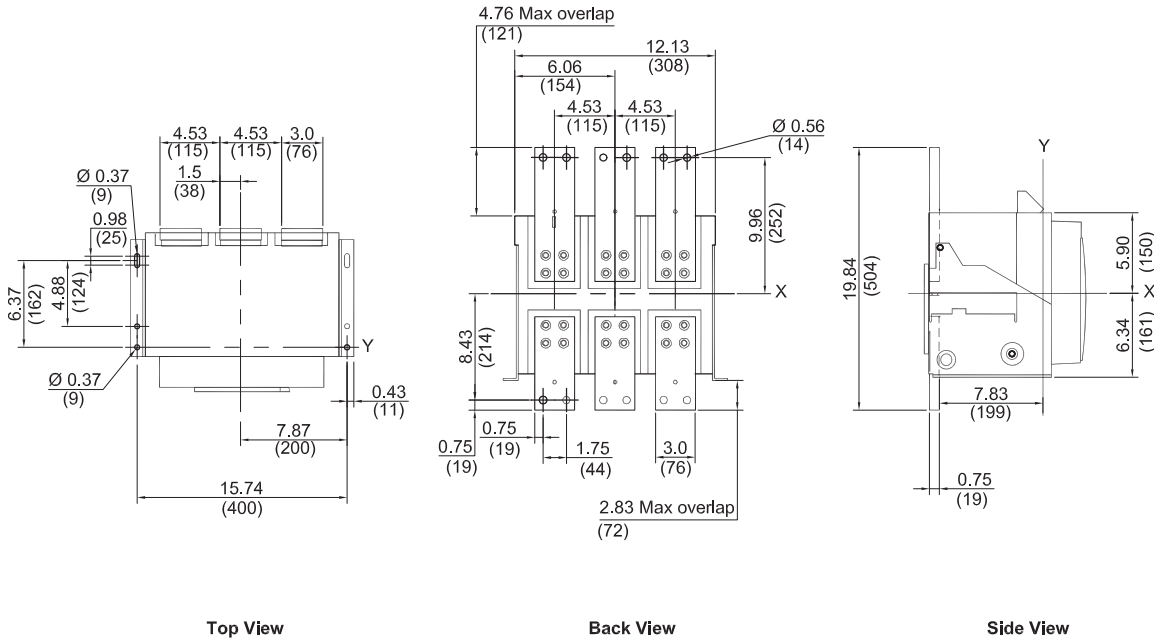

Dimensions: in.  
(mm)

# Masterpact™ NT and NW Universal Power Circuit Breakers

## Masterpact NW Dimensional Drawings

Figure 95: 800–3000 A Front-Connected "T" (FCT)

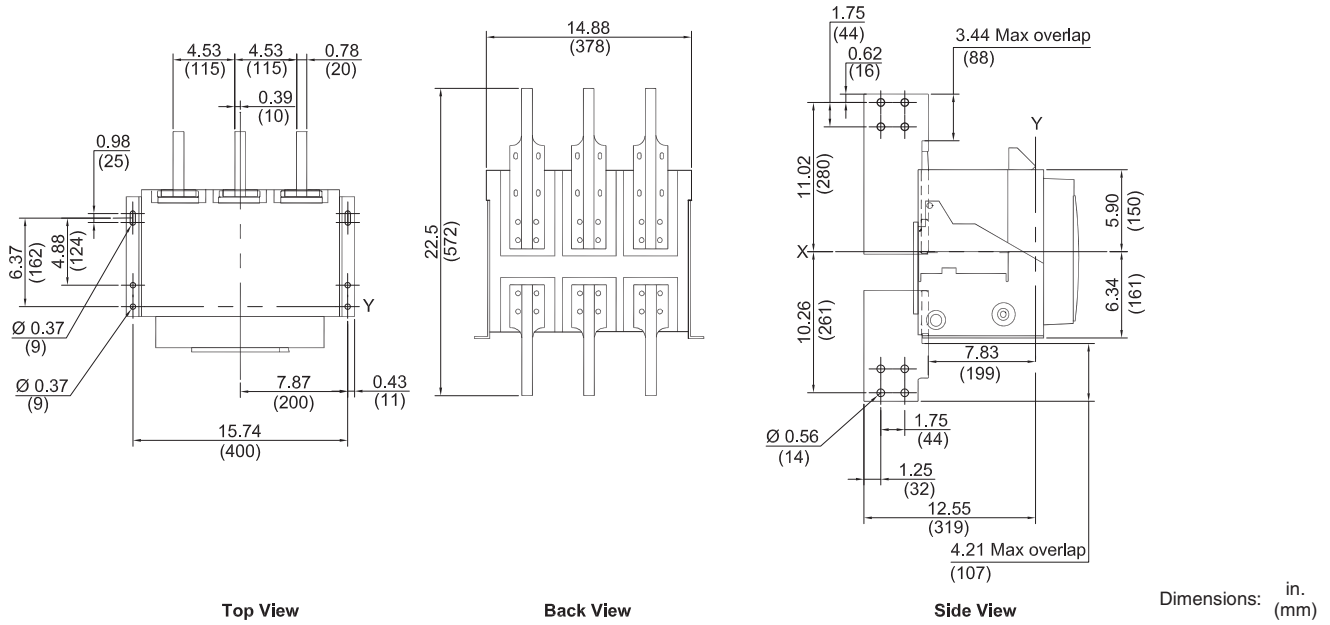
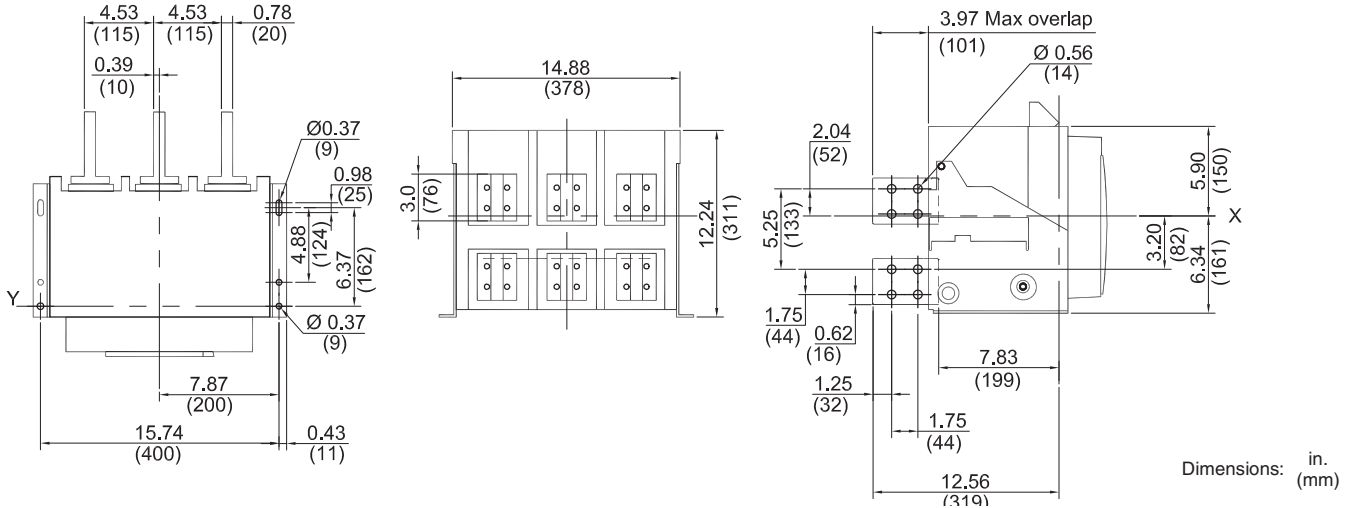

Figure 96: 2500–3000 A Rear-Connected Vertical "T" Horizontal (RCTV)



# Masterpact™ NT and NW Universal Power Circuit Breakers

## Masterpact NW Dimensional Drawings

**Figure 97: 2500–3000 A Rear-Connected "T" Horizontal (RCH)**

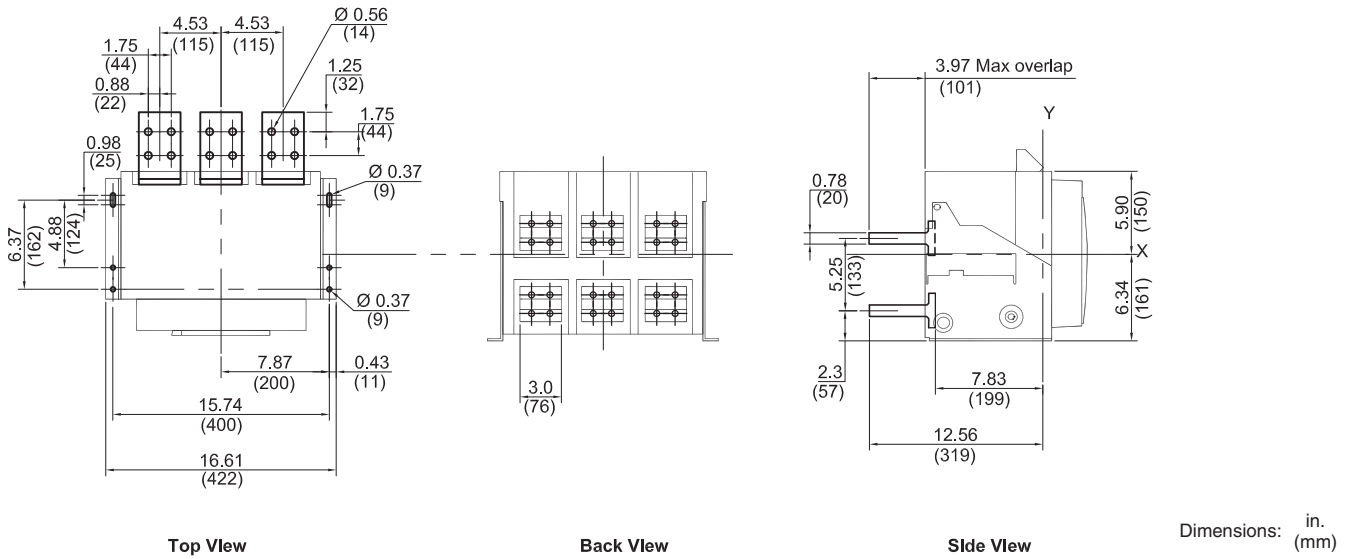

**Figure 98: 2000 A L1 and 3200 A Rear-Connected Offset Vertical (RCOV)**

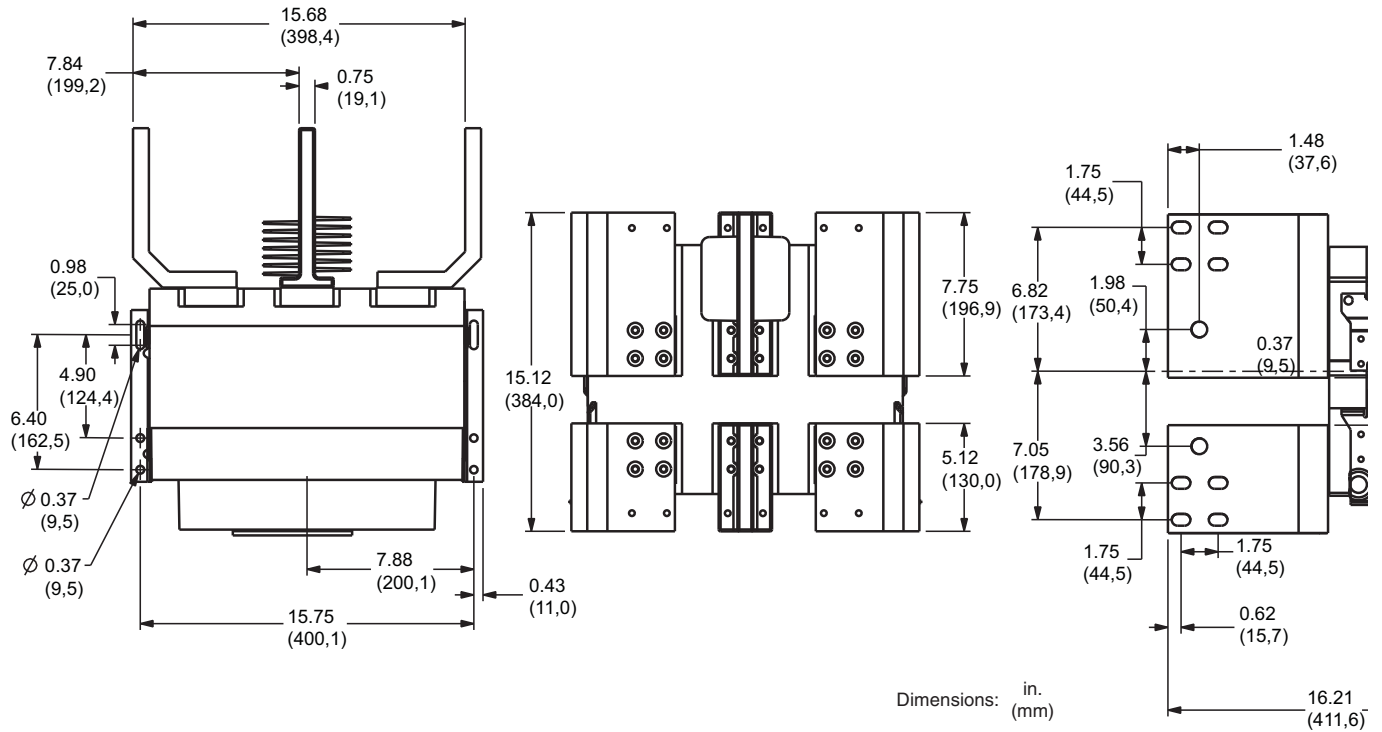

# Masterpact™ NT and NW Universal Power Circuit Breakers

## Masterpact NW Dimensional Drawings

Figure 99: 4000 A (W-Frame) Rear-Connected Offset Vertical (RCOV)

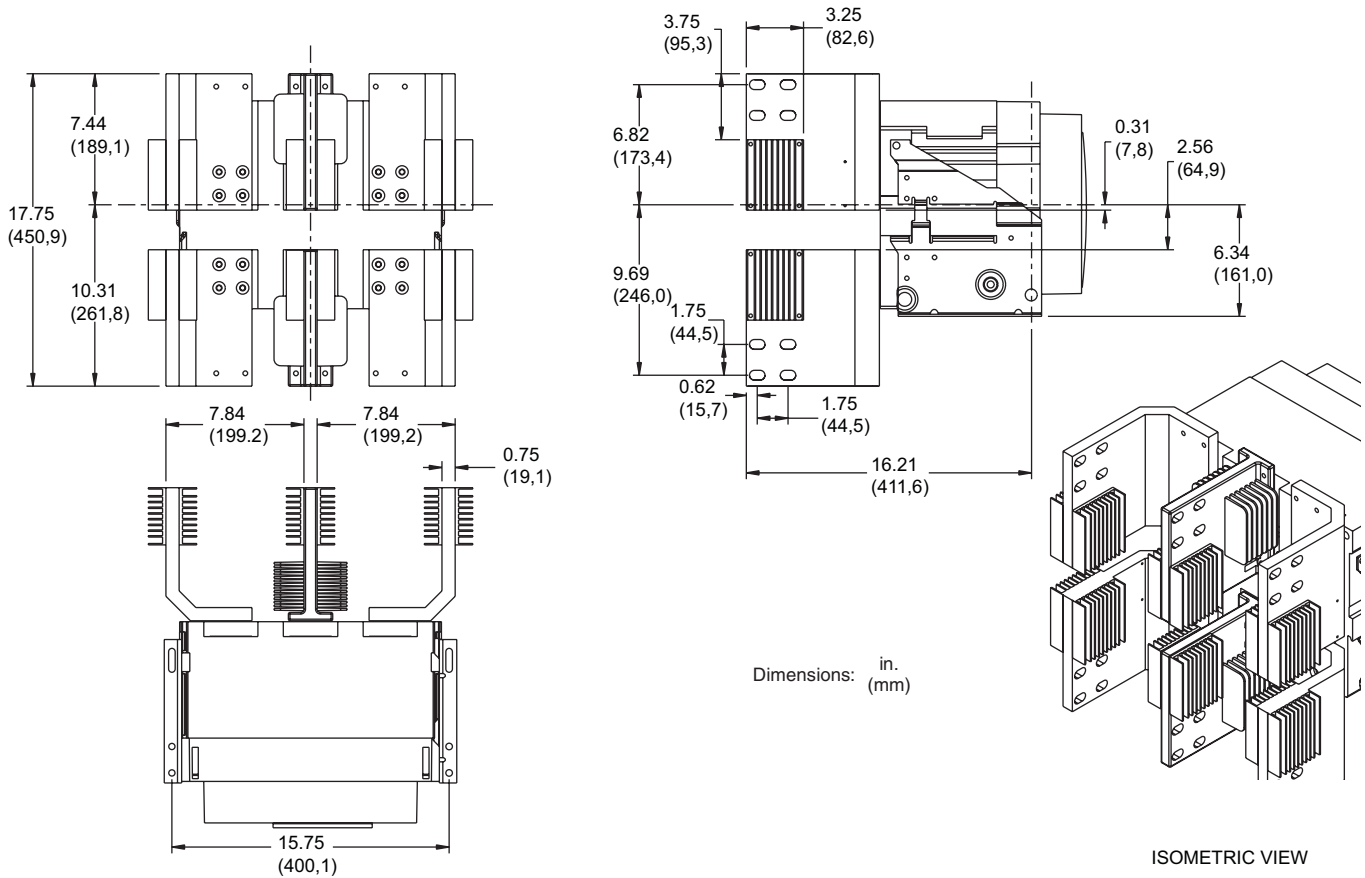
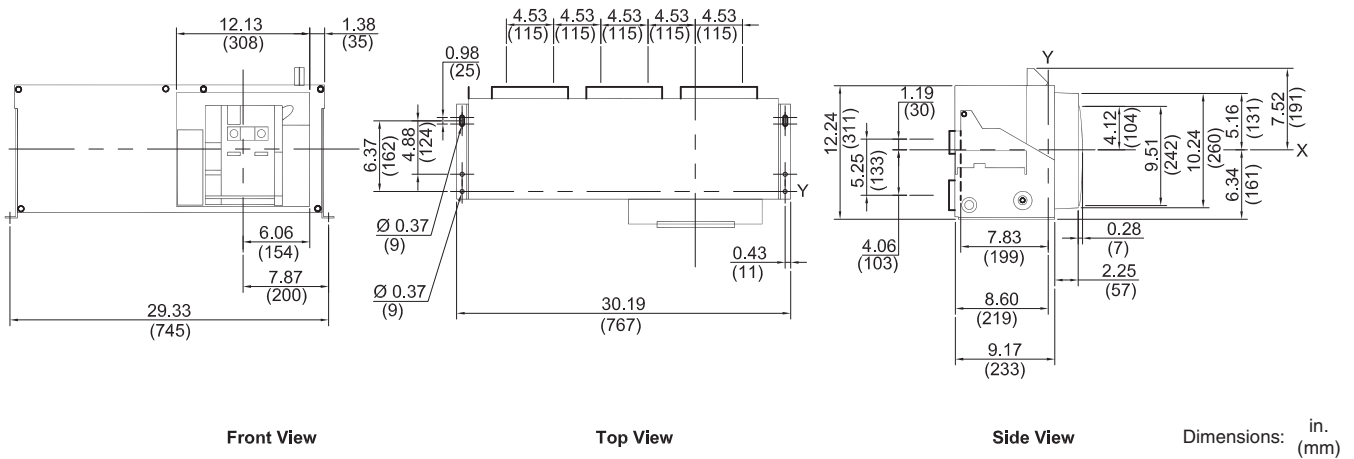

Figure 100: 4000–6000 A Master Drawing



# Masterpact™ NT and NW Universal Power Circuit Breakers

## Masterpact NW Dimensional Drawings

**Figure 101: 4000–5000 A Rear-Connected "T" Vertical (RCTV)**

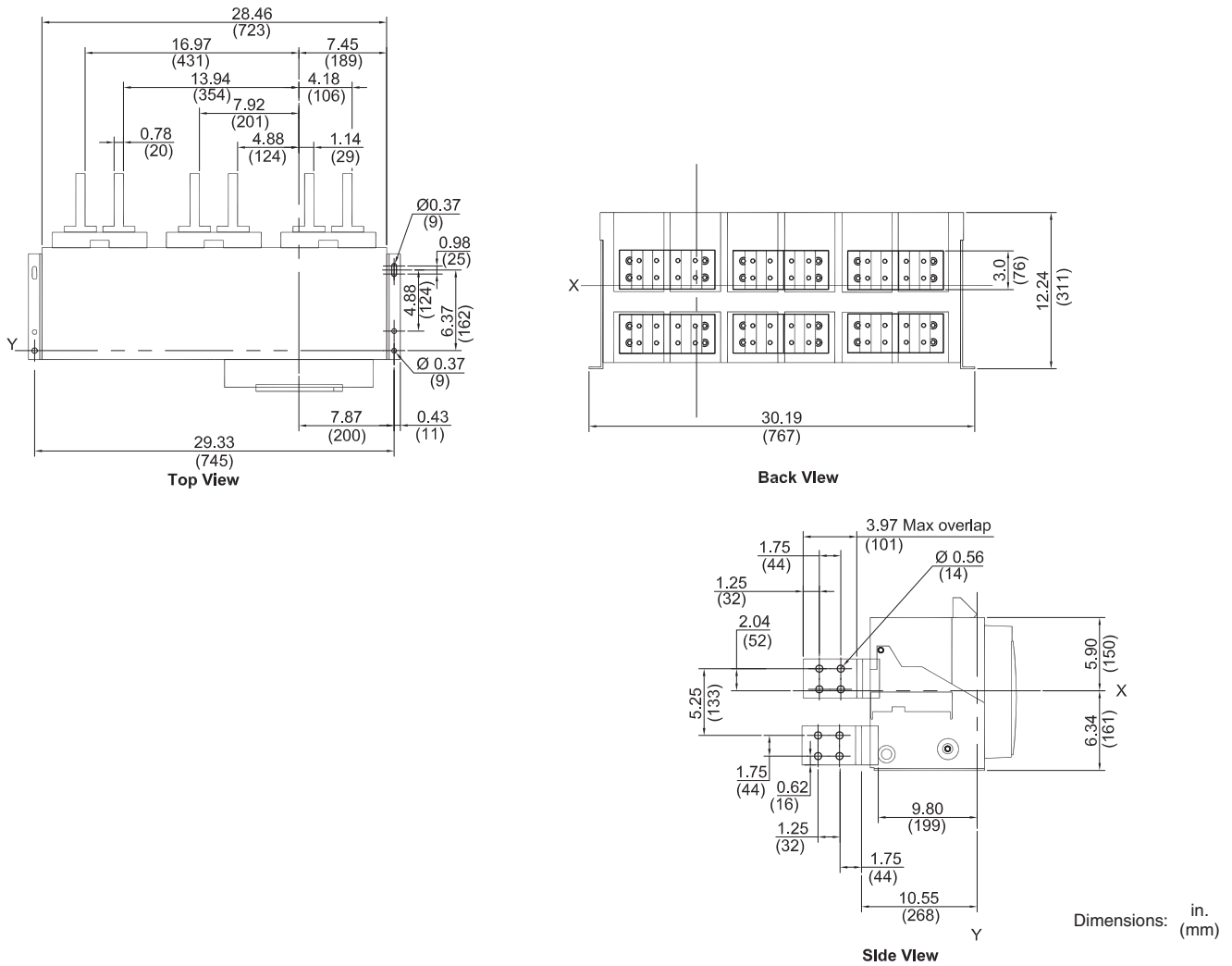

**Figure 102: 4000–5000 A Rear-Connected "T" Horizontal (RCTH)**

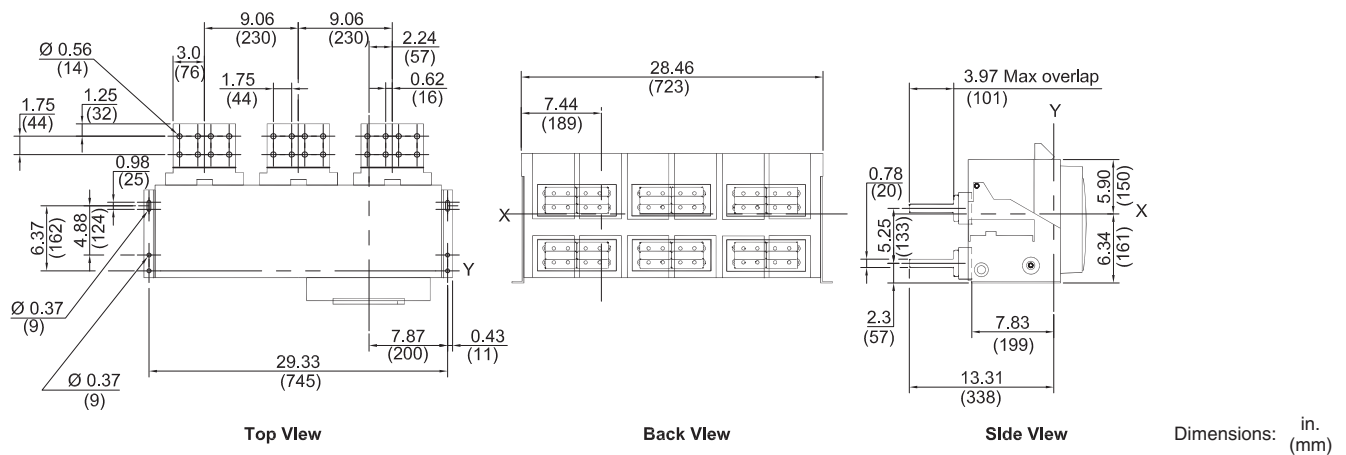

# Masterpact™ NT and NW Universal Power Circuit Breakers

## Masterpact NW Dimensional Drawings

Figure 103: 6000 A Rear-Connected "T" Vertical (RCTV)

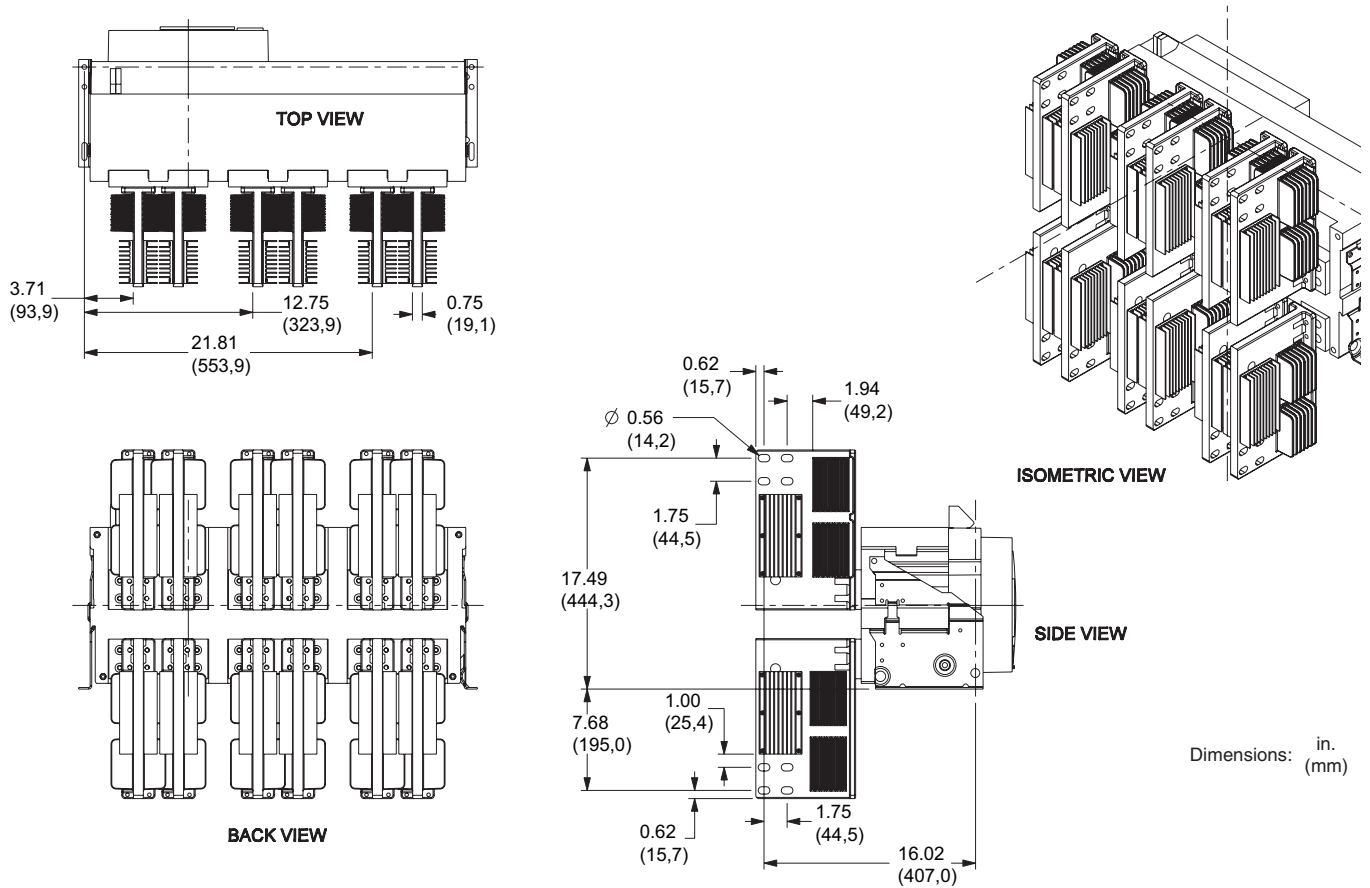
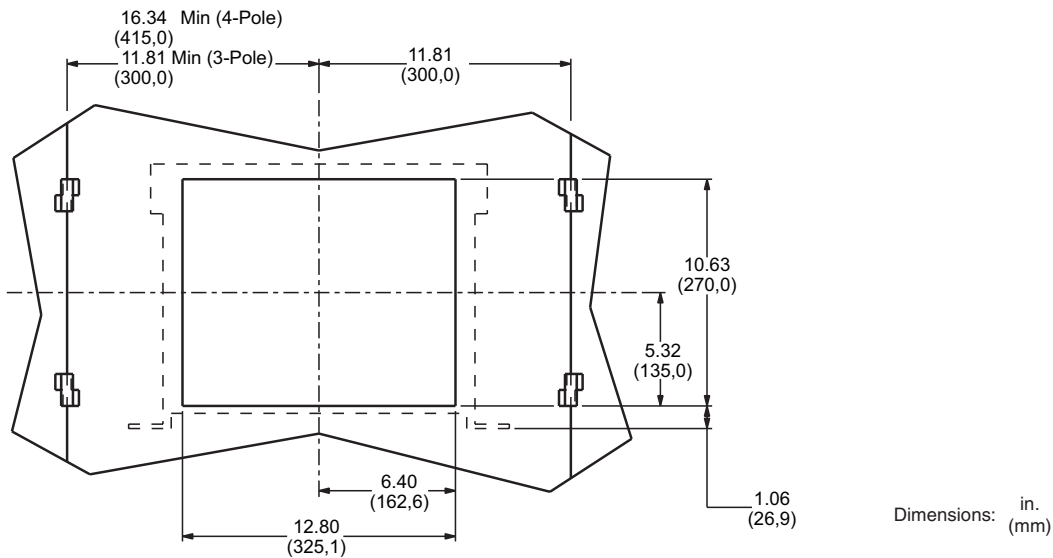

Figure 104: 800–3200 A and 4000 A (W-Frame) Circuit Breaker Door Cutout



# Masterpact™ NT and NW Universal Power Circuit Breakers

## Masterpact NW Dimensional Drawings

**Figure 105: 4000–6000 A Door Cutout**

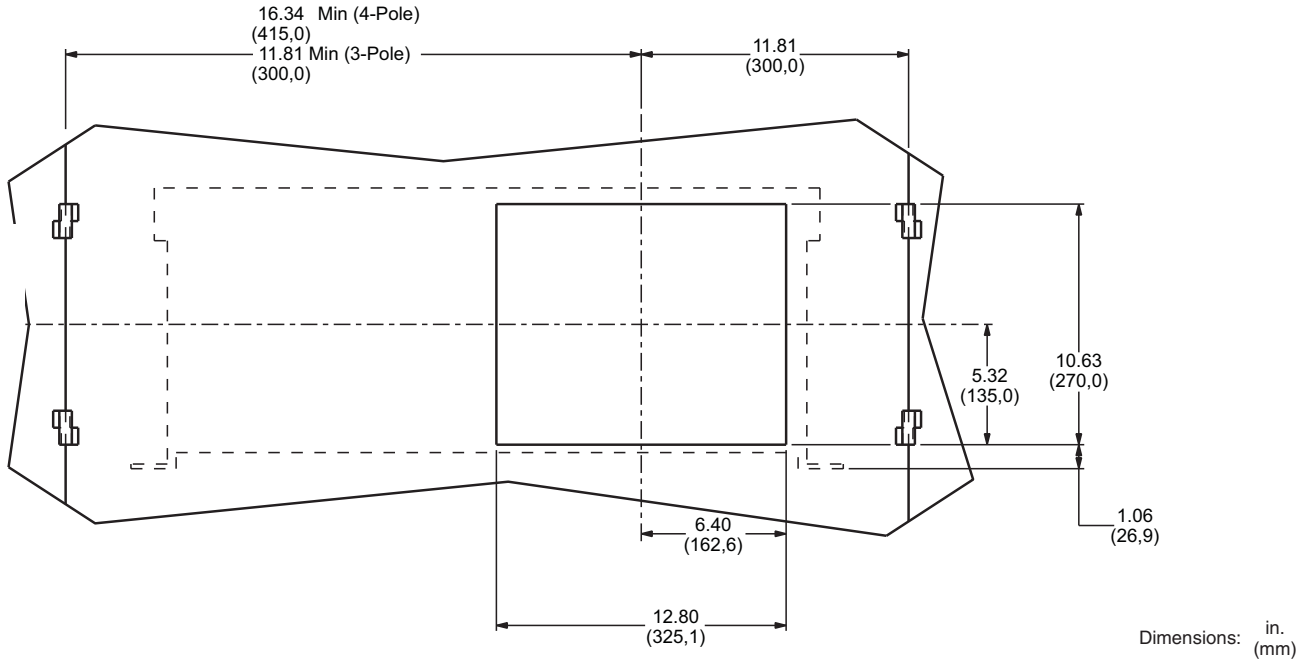

## UL/ANSI Four-Pole Drawout Circuit Breakers

**Figure 106: 800–3000 A and 3200 A Master Drawing**

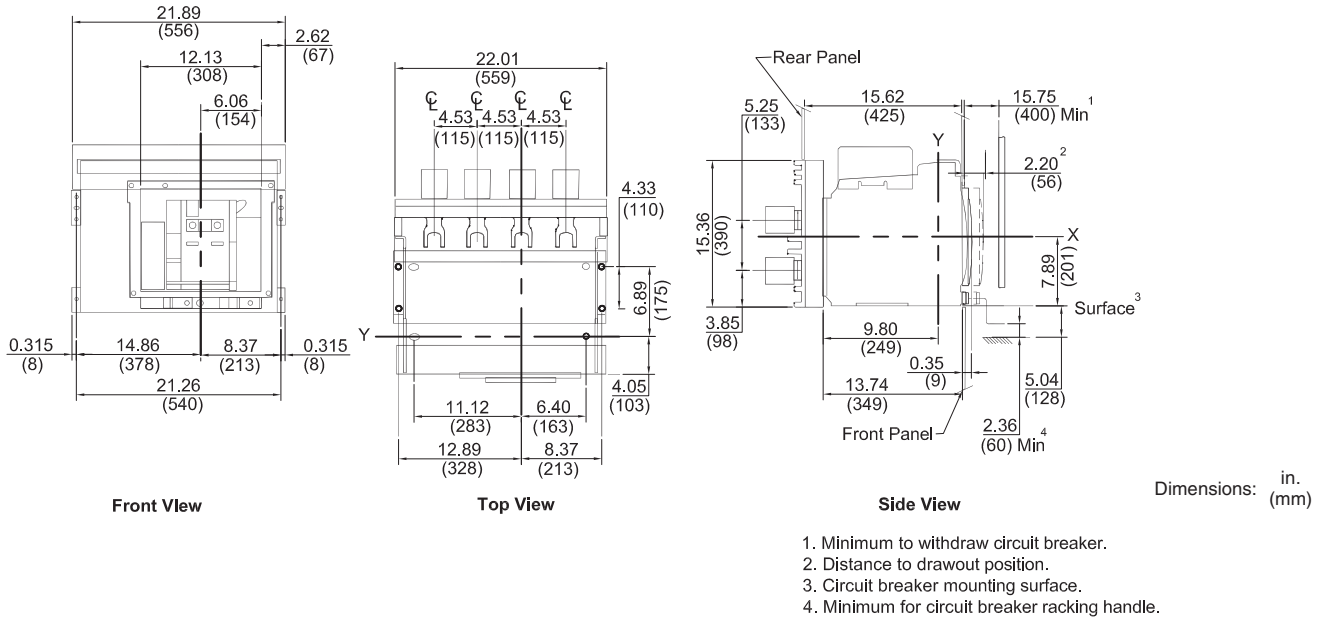

# Masterpact™ NT and NW Universal Power Circuit Breakers

## Masterpact NW Dimensional Drawings

Figure 107: 800–2000 A Rear-Connected "T" Vertical (RCTV)

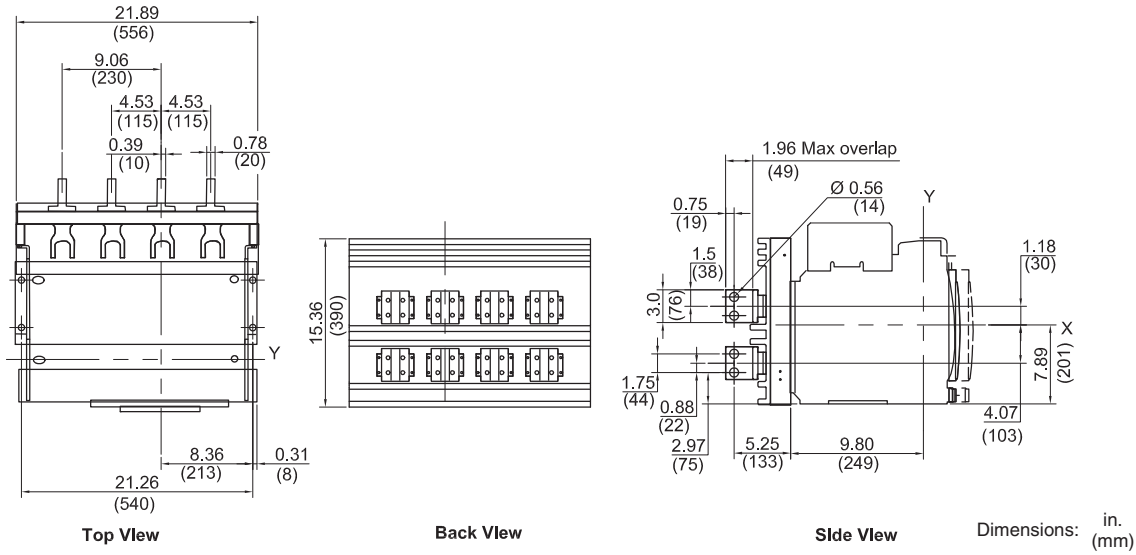
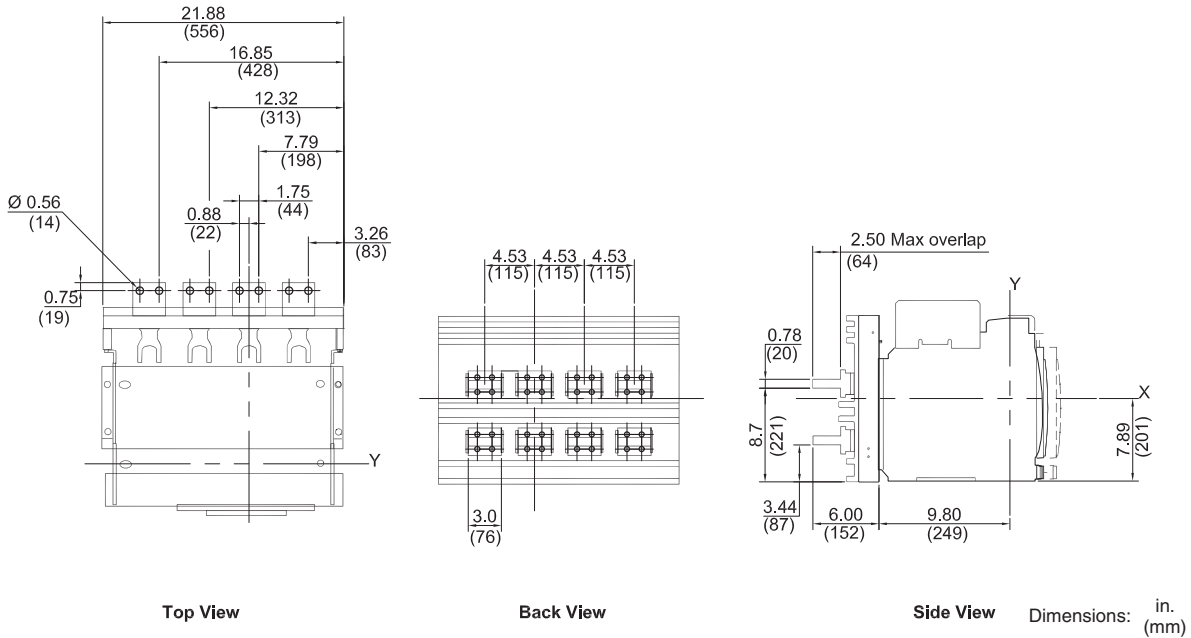

Figure 108: 800–2000 A Rear-Connected "T" Horizontal (RCH)





# Masterpact™ NT and NW Universal Power Circuit Breakers

## Masterpact NW Dimensional Drawings

**Figure 109: 800–2000 A Front-Connected Flat (FCF)**

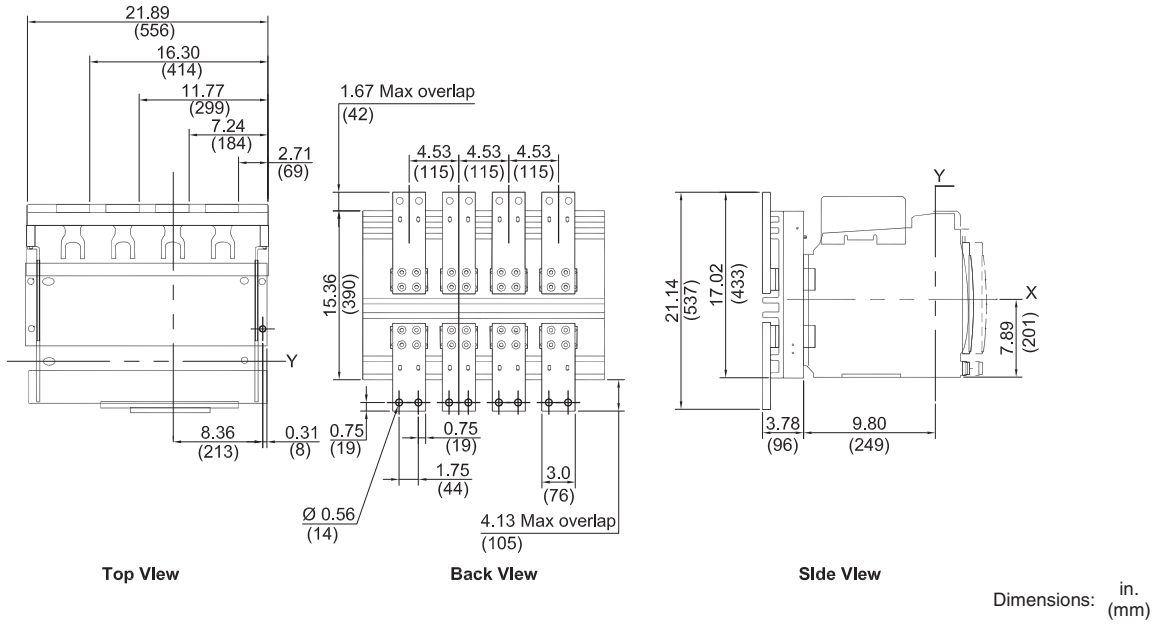

**Figure 110: 800–3000 A Front-Connected "T" (FCT)**

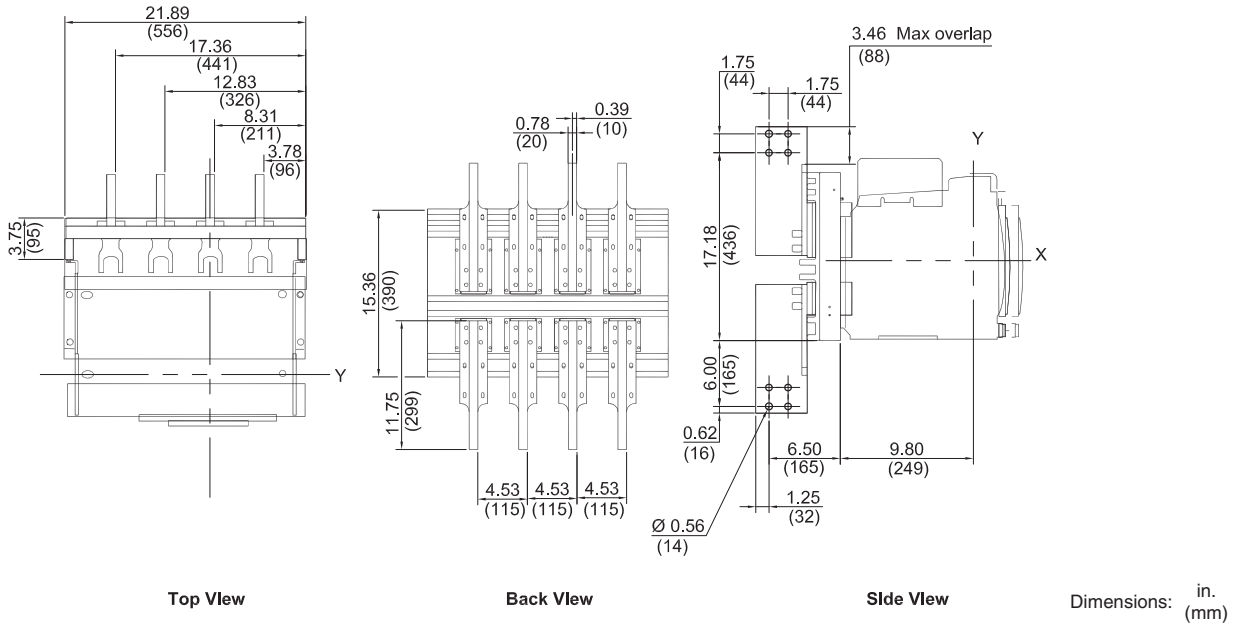



# Masterpact™ NT and NW Universal Power Circuit Breakers

## Masterpact NW Dimensional Drawings

**Figure 113: 2000 A L1 and 3200 A Rear-Connected Offset Vertical (RCOV)**

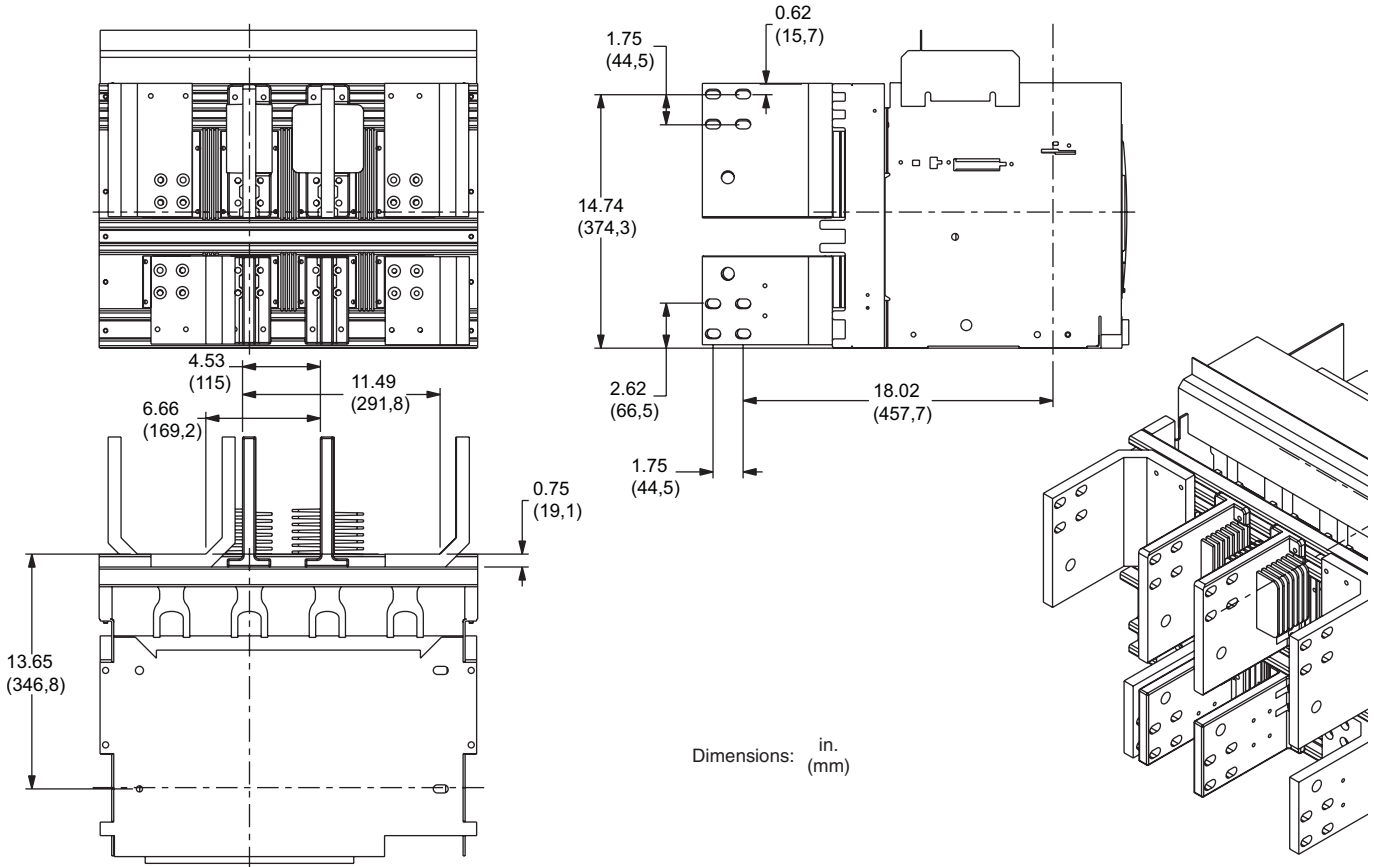



# Masterpact™ NT and NW Universal Power Circuit Breakers Masterpact NW Dimensional Drawings

**Figure 115: 3200 A L1 and 4000–5000 A Rear-Connected "T" Vertical (RCTV)**

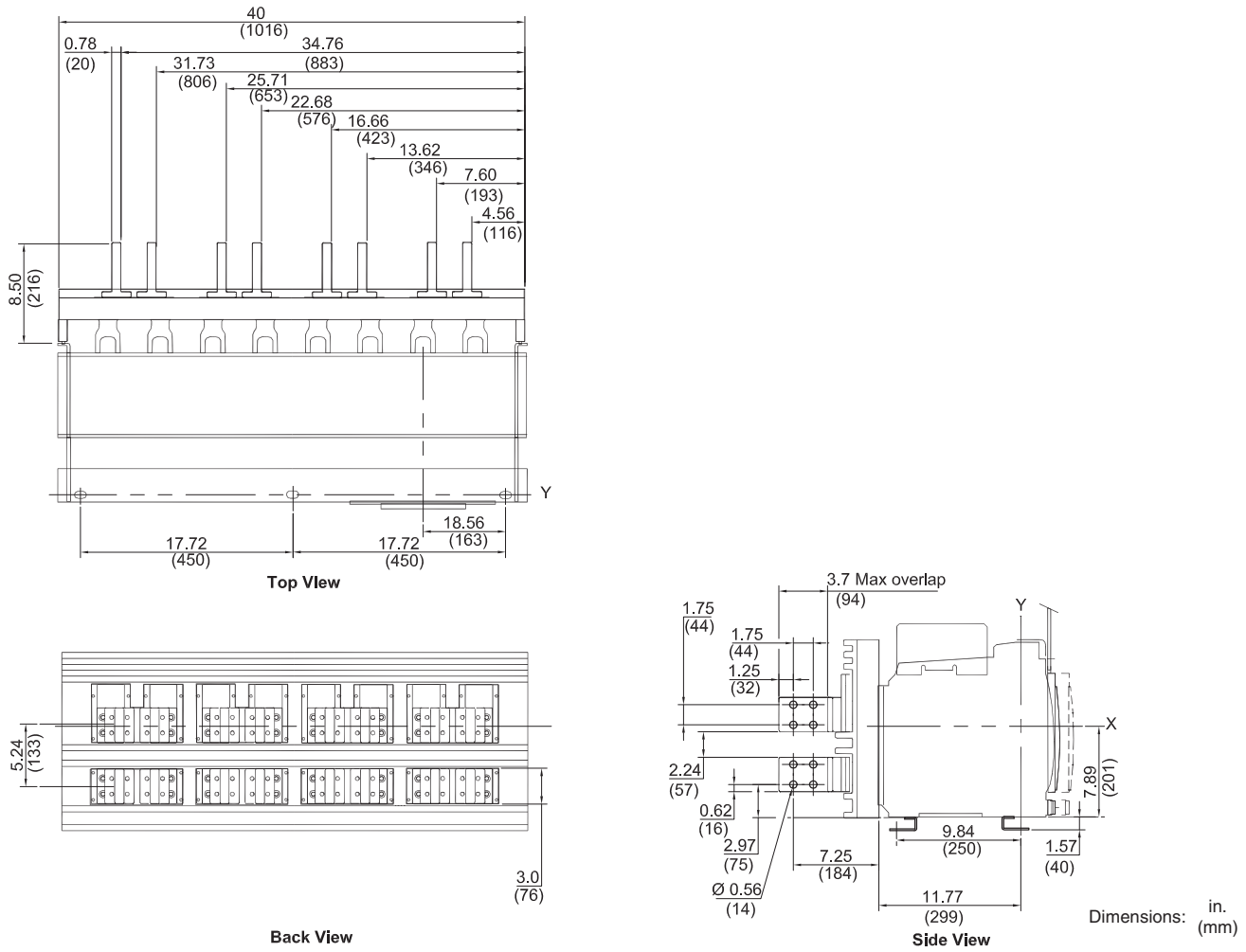

# Masterpact™ NT and NW Universal Power Circuit Breakers

## Masterpact NW Dimensional Drawings

Figure 116: 3200 A L1 and 4000–5000 A Rear-Connected "T" Horizontal (RCTH)

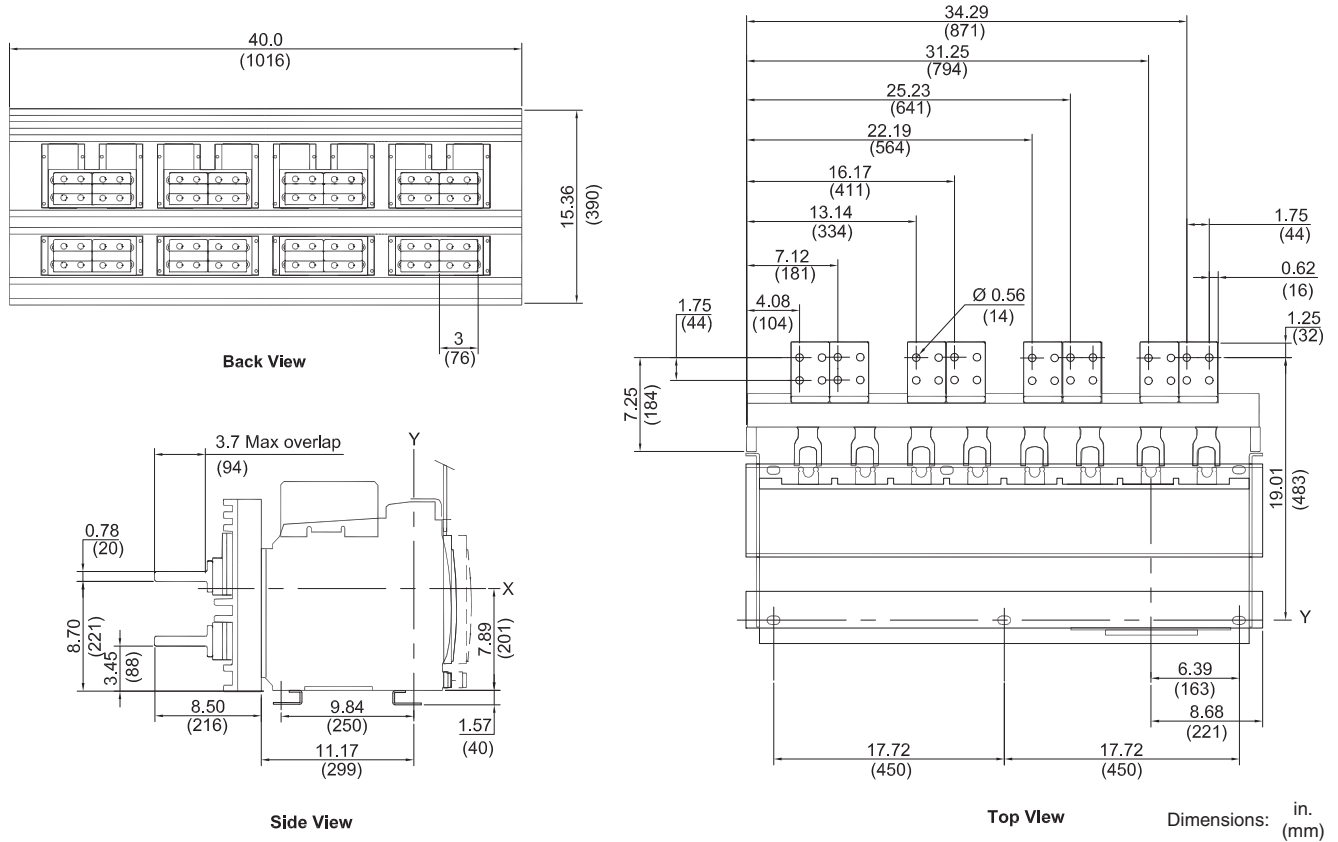

# Masterpact™ NT and NW Universal Power Circuit Breakers

## Masterpact NW Dimensional Drawings

**Figure 117: 3200 A L1 and 4000 A Front-Connected Flat (FCF)**

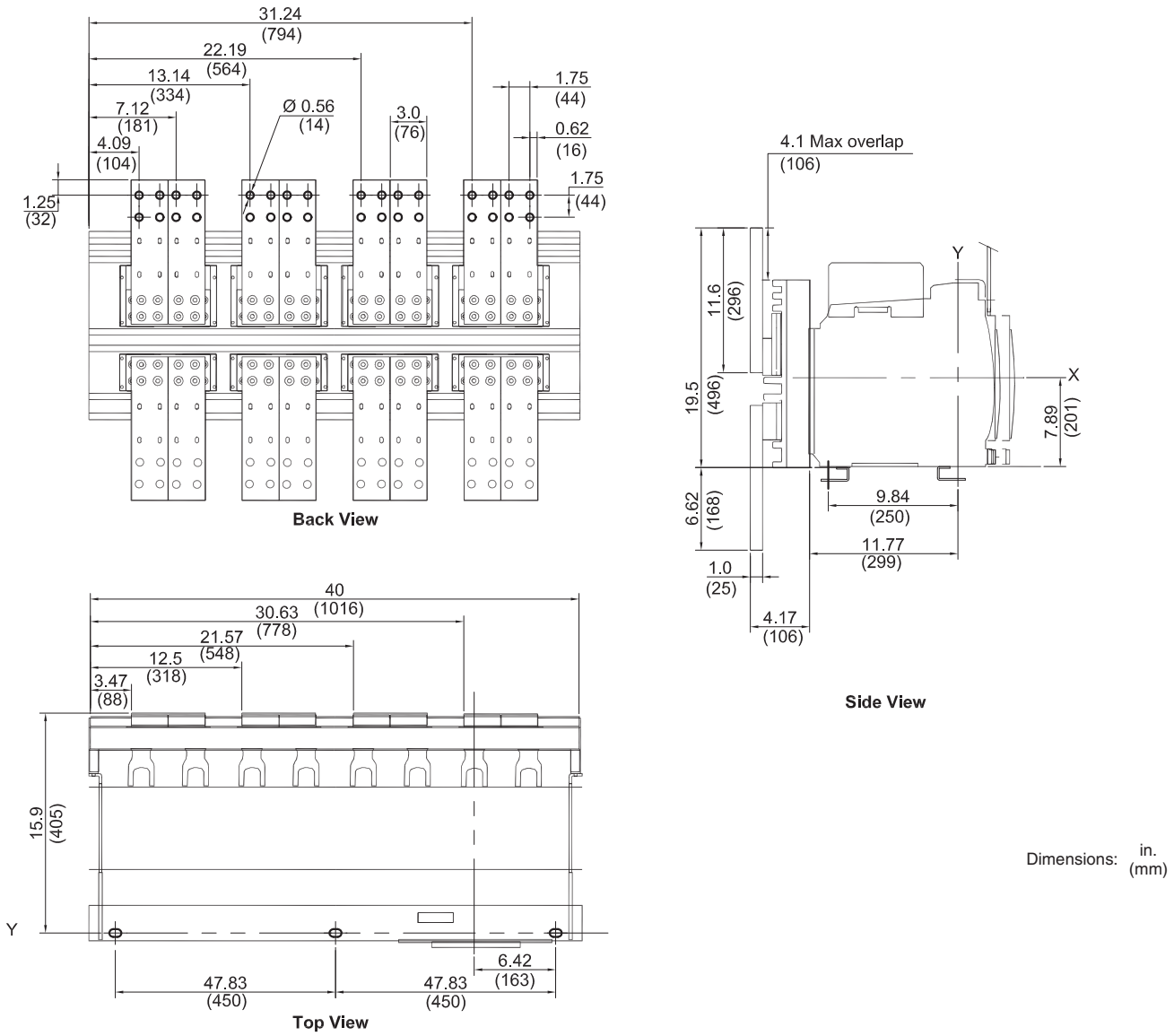

# Masterpact™ NT and NW Universal Power Circuit Breakers

## Masterpact NW Dimensional Drawings

Figure 118: 3200 A L1 and 4000–5000 A Front-Connected "T" (FCT)

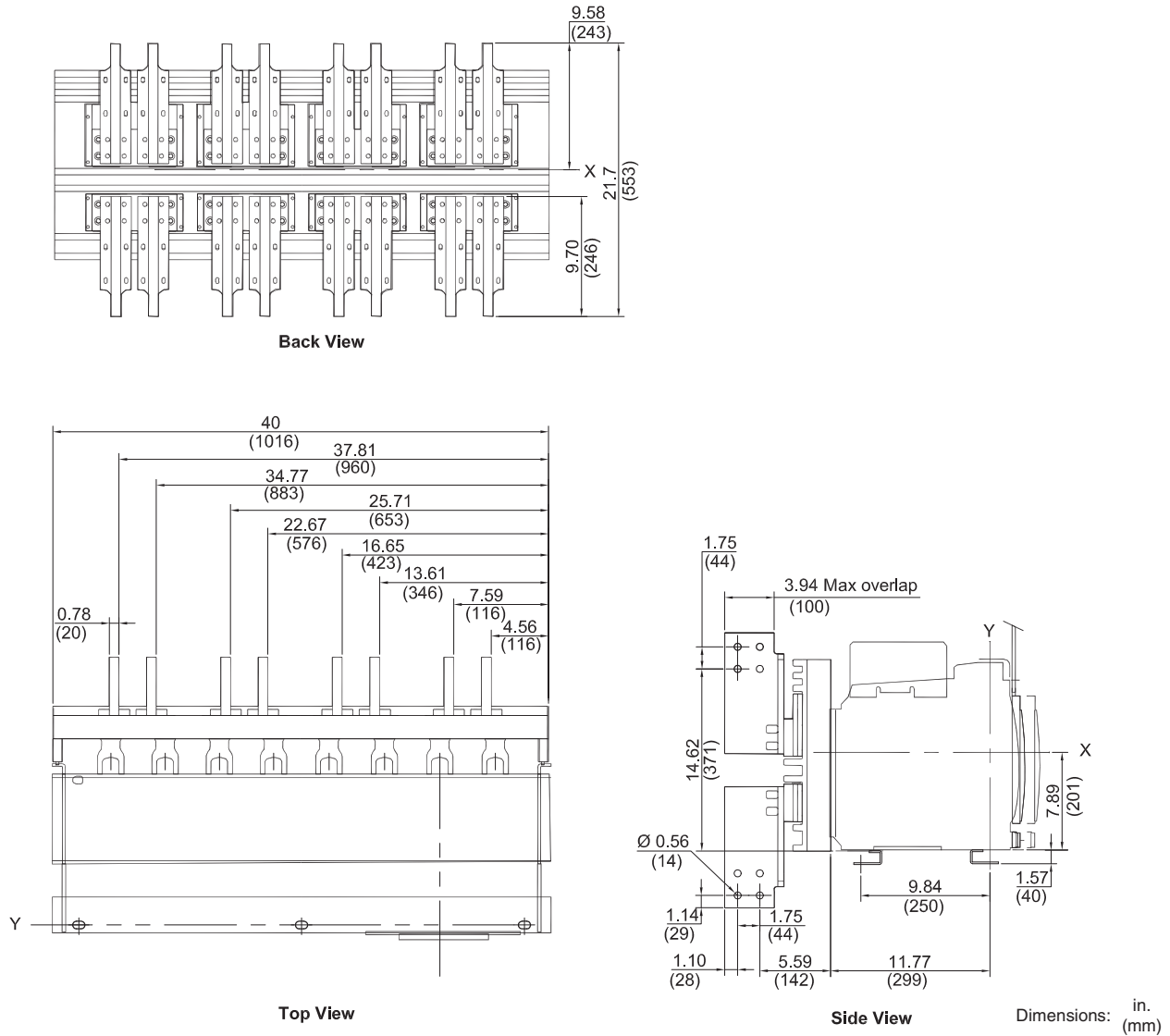



# Masterpact™ NT and NW Universal Power Circuit Breakers

## Masterpact NW Dimensional Drawings

**Figure 119: 6000 A Rear-Connected "T" Vertical (RCTV)**

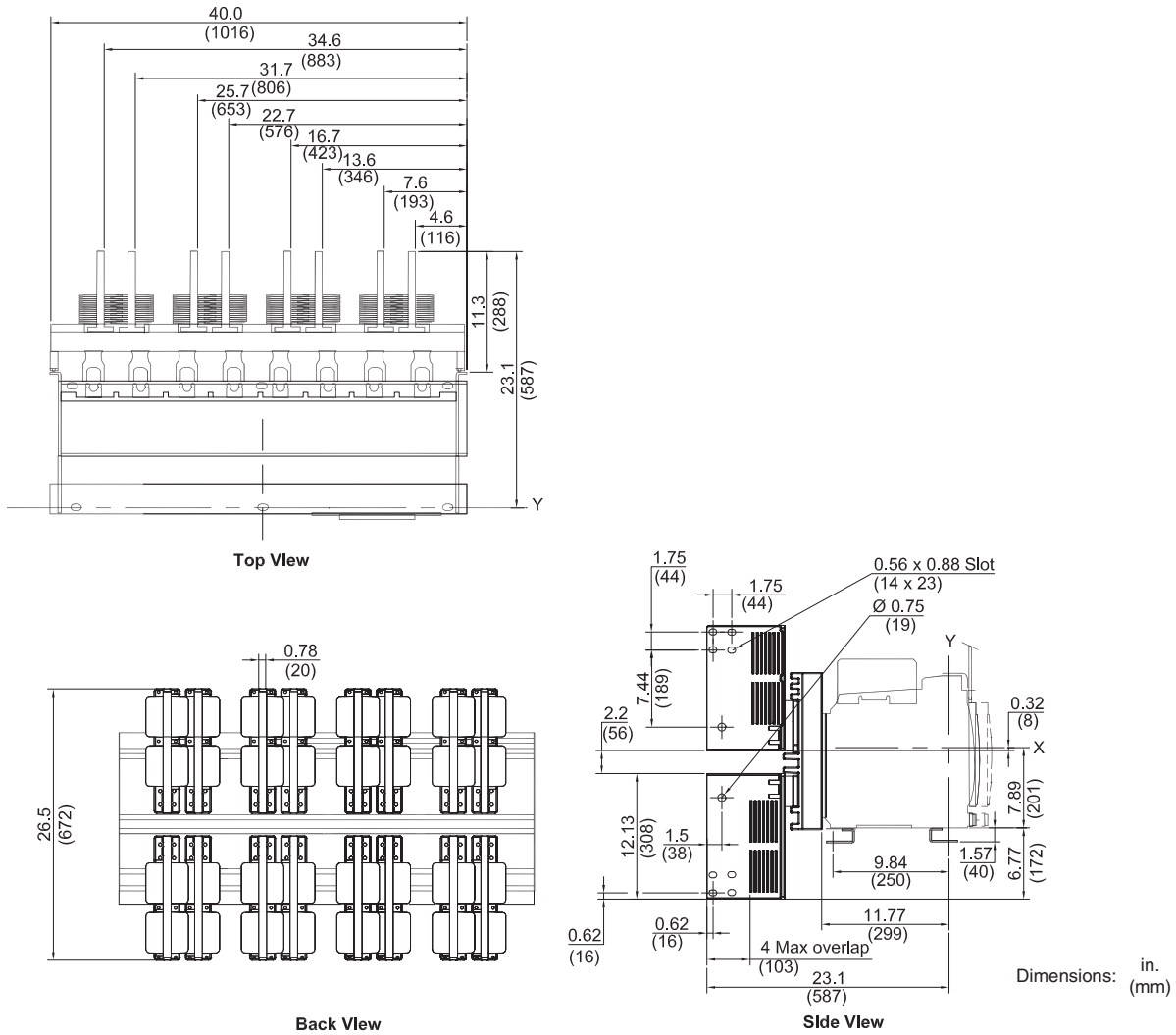

**Masterpact™ NT and NW Universal Power Circuit Breakers**  
**Masterpact NW Dimensional Drawings**

**UL/ANSI Four-Pole Fixed Circuit Breakers**

**Figure 120: 800–3000 A, 3200 A and 4000 A (W-Frame) Master Drawing**

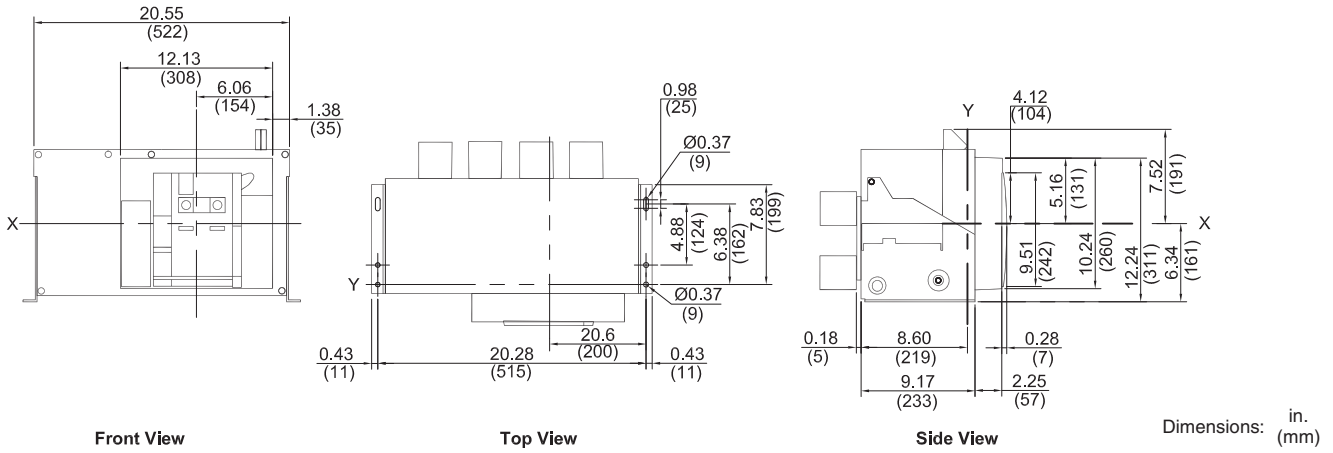

**Figure 121: 800–2000 A Rear-Connected "T" Vertical (RCTV)**

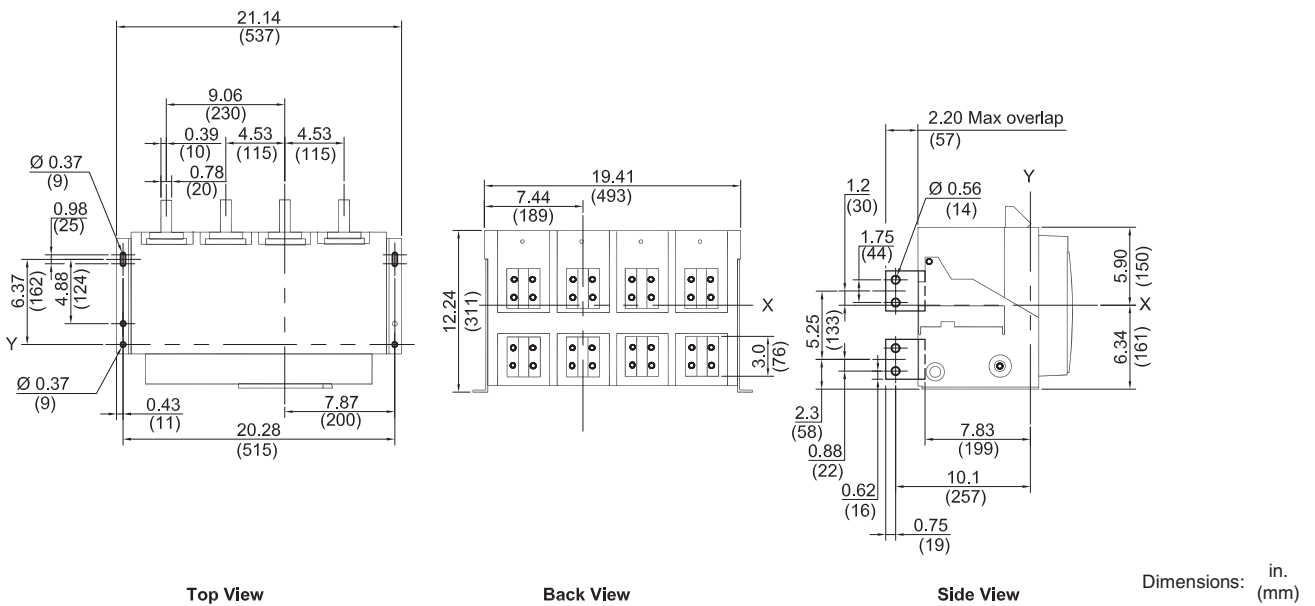

# Masterpact™ NT and NW Universal Power Circuit Breakers

## Masterpact NW Dimensional Drawings

**Figure 122: 800–2000 A Rear-Connected "T" Horizontal (RCTH)**

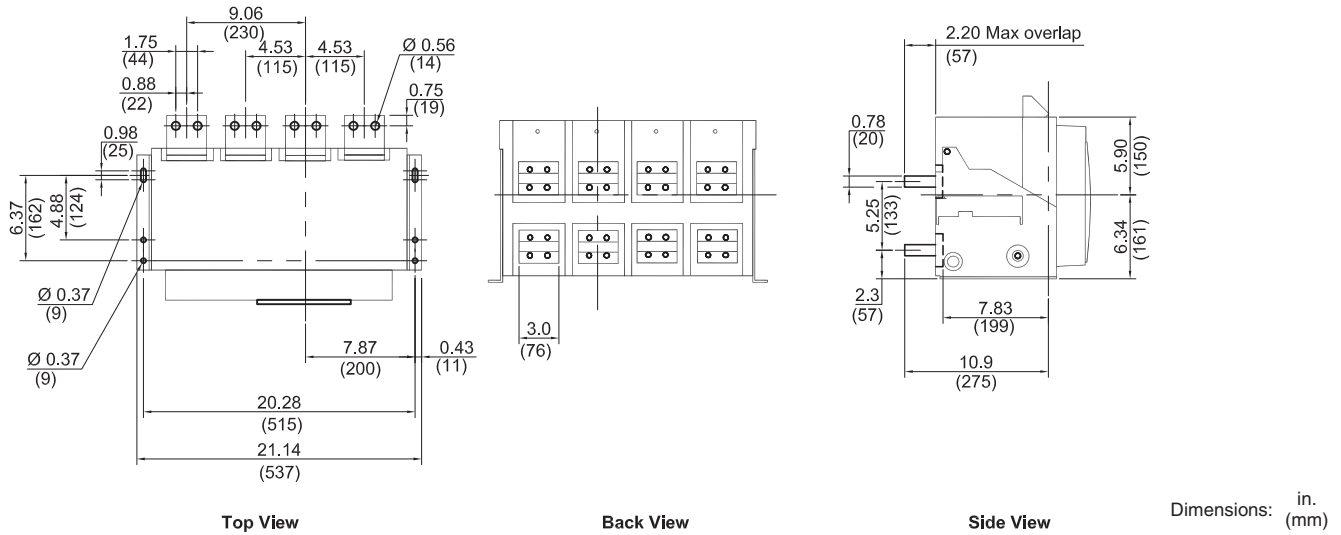

**Figure 123: 800–2000 A Front-Connected Flat (FCF)**

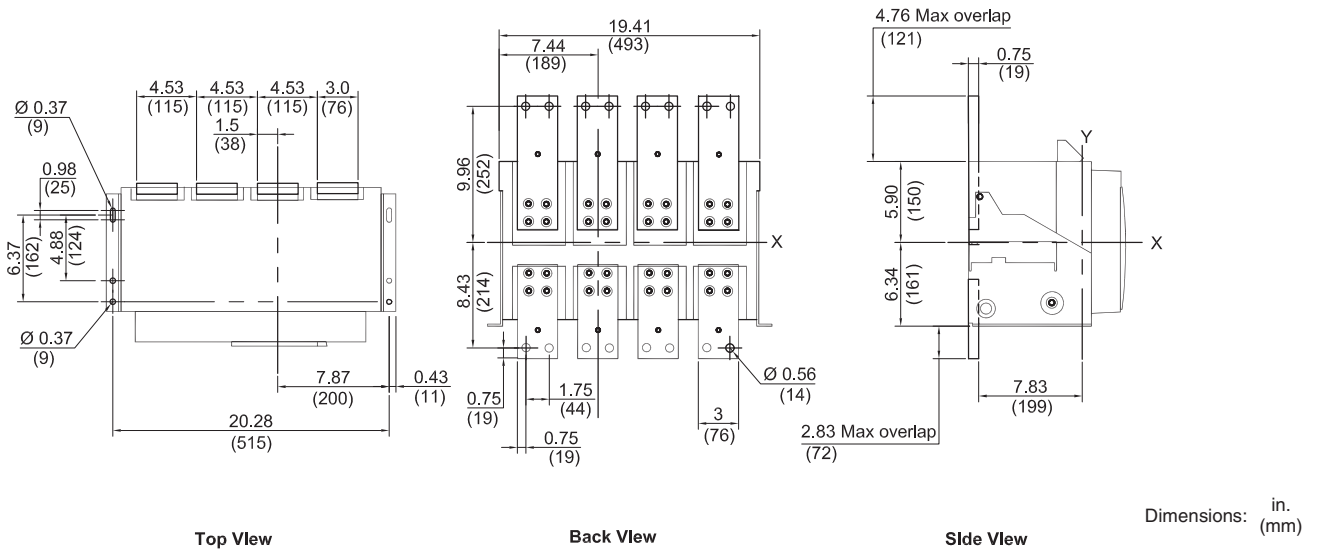



# Masterpact™ NT and NW Universal Power Circuit Breakers

## Masterpact NW Dimensional Drawings

**Figure 125: 2000 A L1 and 3200 A Rear-Connected Offset Vertical (RCOV)**

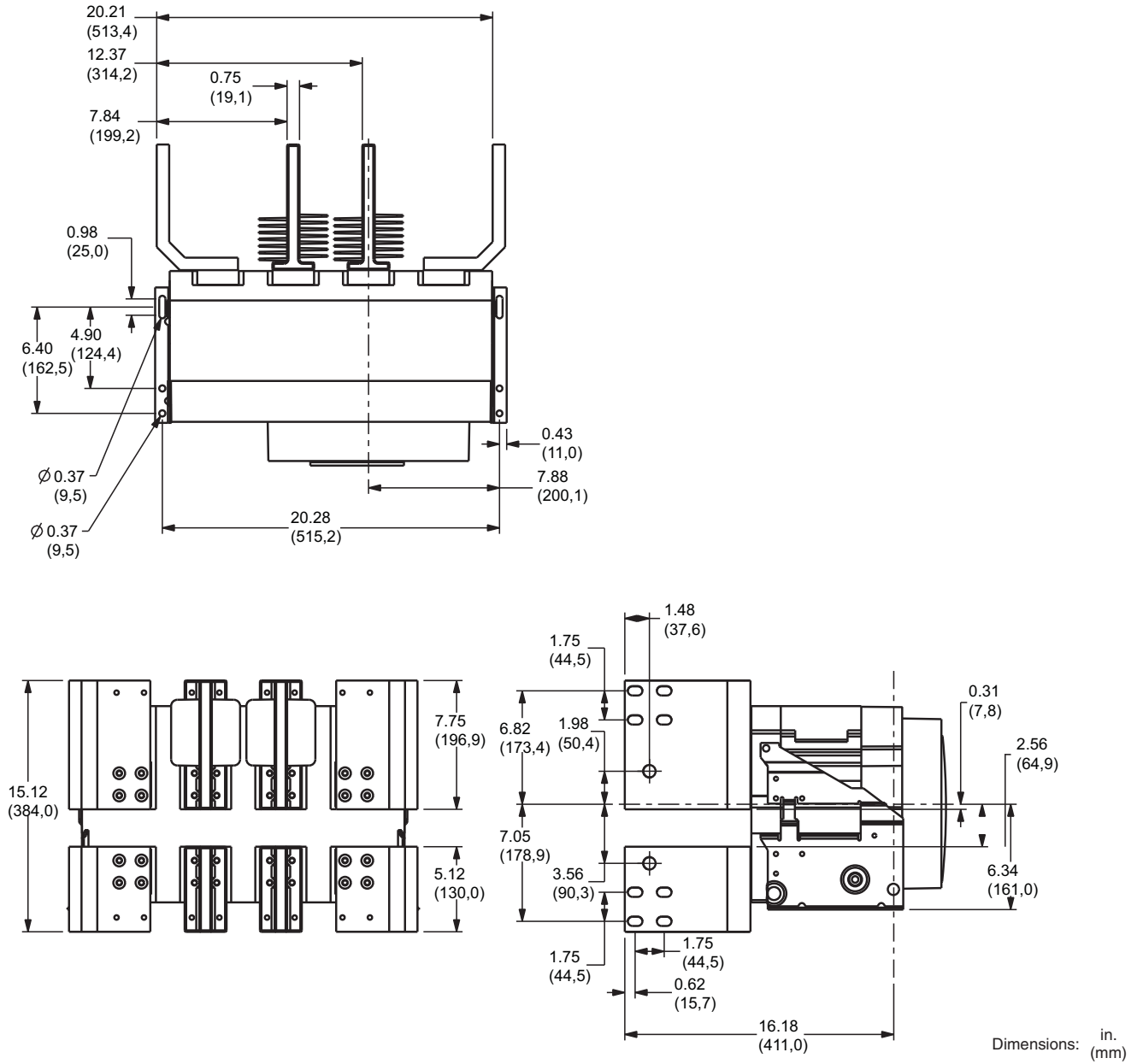

# Masterpact™ NT and NW Universal Power Circuit Breakers

## Masterpact NW Dimensional Drawings

Figure 126: 2500–3000 A Rear Vertical "T" Horizontal (RCTV)

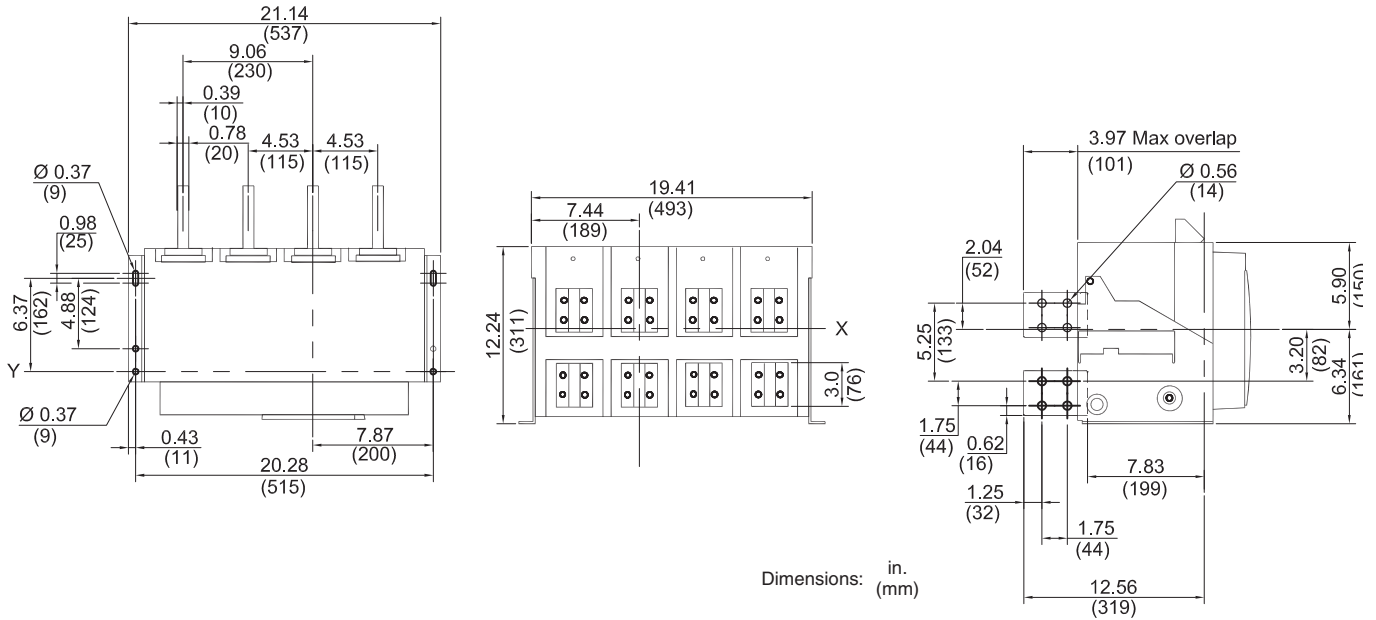
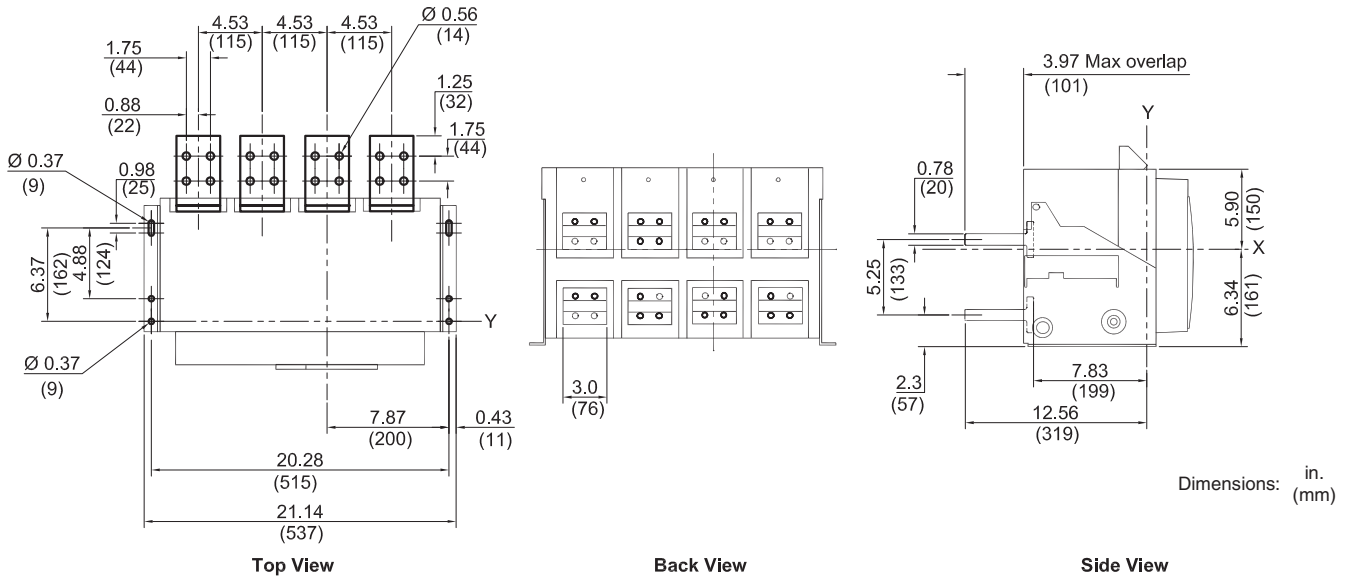

Figure 127: 2500–3000 A Rear-Connected "T" Horizontal (RCTH)



# Masterpact™ NT and NW Universal Power Circuit Breakers

## Masterpact NW Dimensional Drawings

**Figure 128: 4000–6000 A Master Drawing**

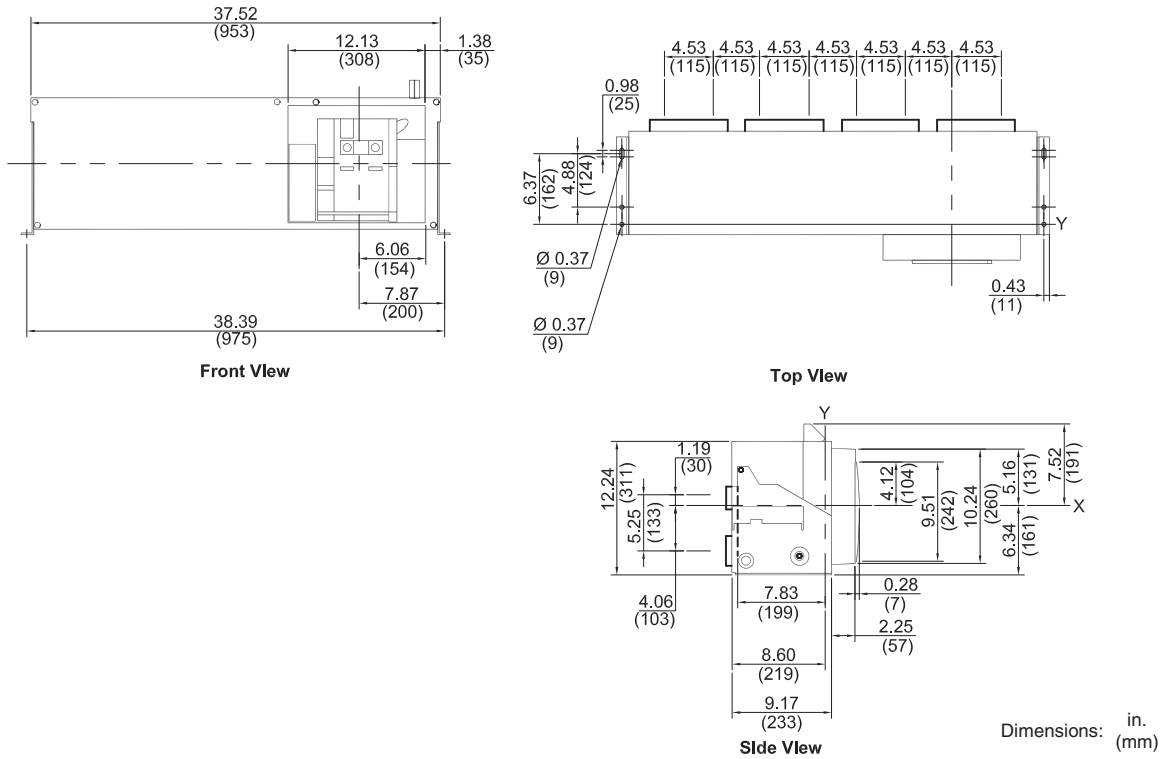

# Masterpact™ NT and NW Universal Power Circuit Breakers

## Masterpact NW Dimensional Drawings

Figure 129: 4000–5000 A Rear-Connected "T" Vertical (RCTV)

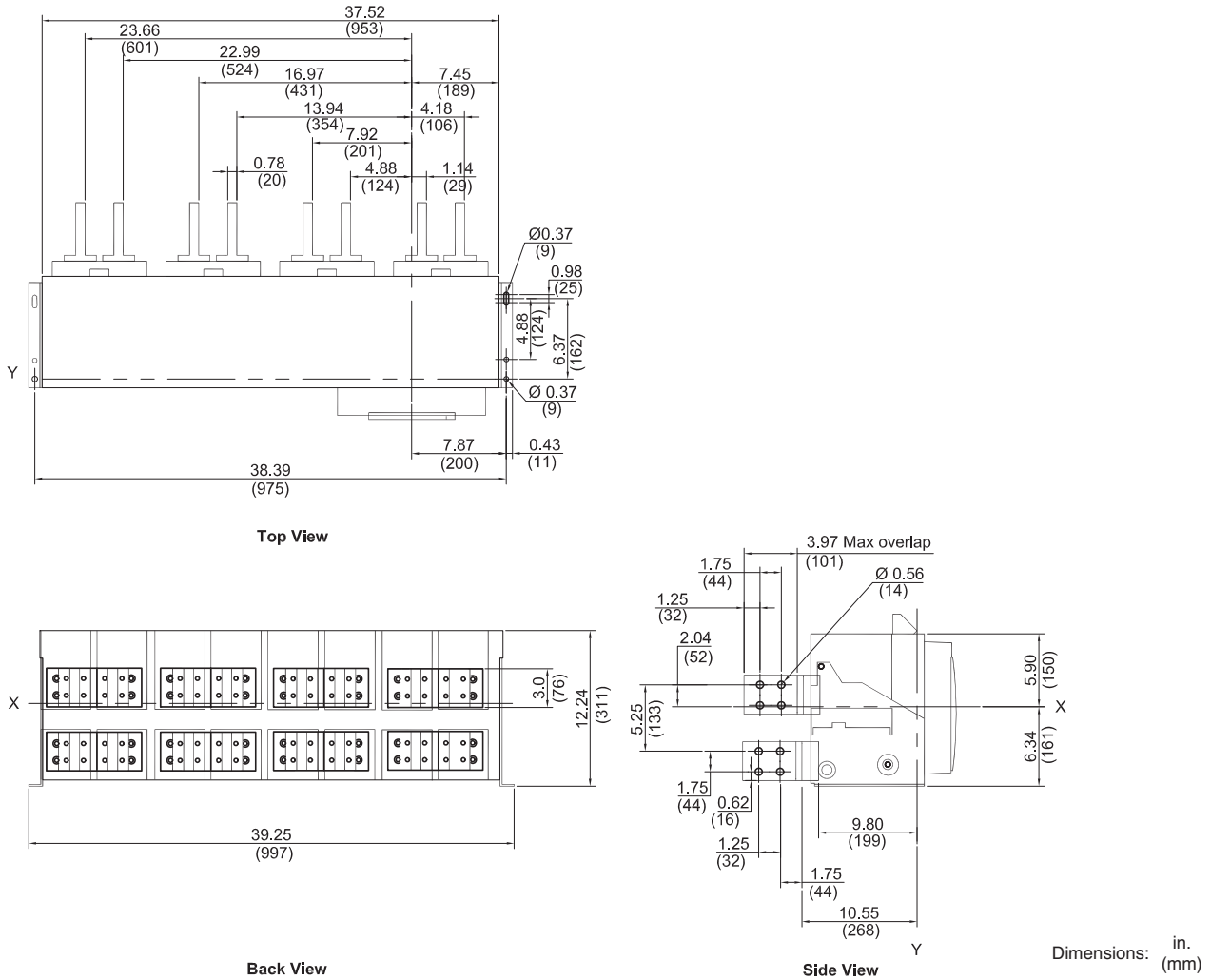



# Masterpact™ NT and NW Universal Power Circuit Breakers

## Masterpact NW Dimensional Drawings

**Figure 130: 4000–5000 A Rear-Connected "T" Horizontal (RCTH)**

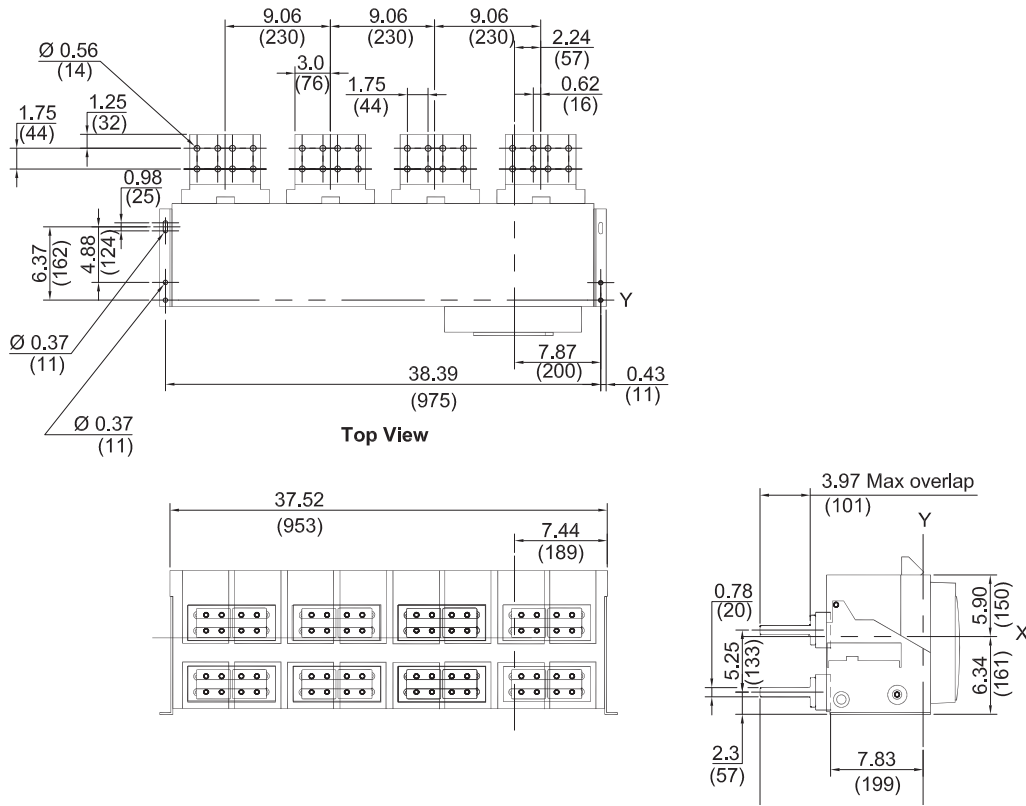

Dimensions: in.  
(mm)

# Masterpact™ NT and NW Universal Power Circuit Breakers

## Masterpact NW Dimensional Drawings

Figure 131: 6000 A Rear-Connected "T" Vertical (RCTV)

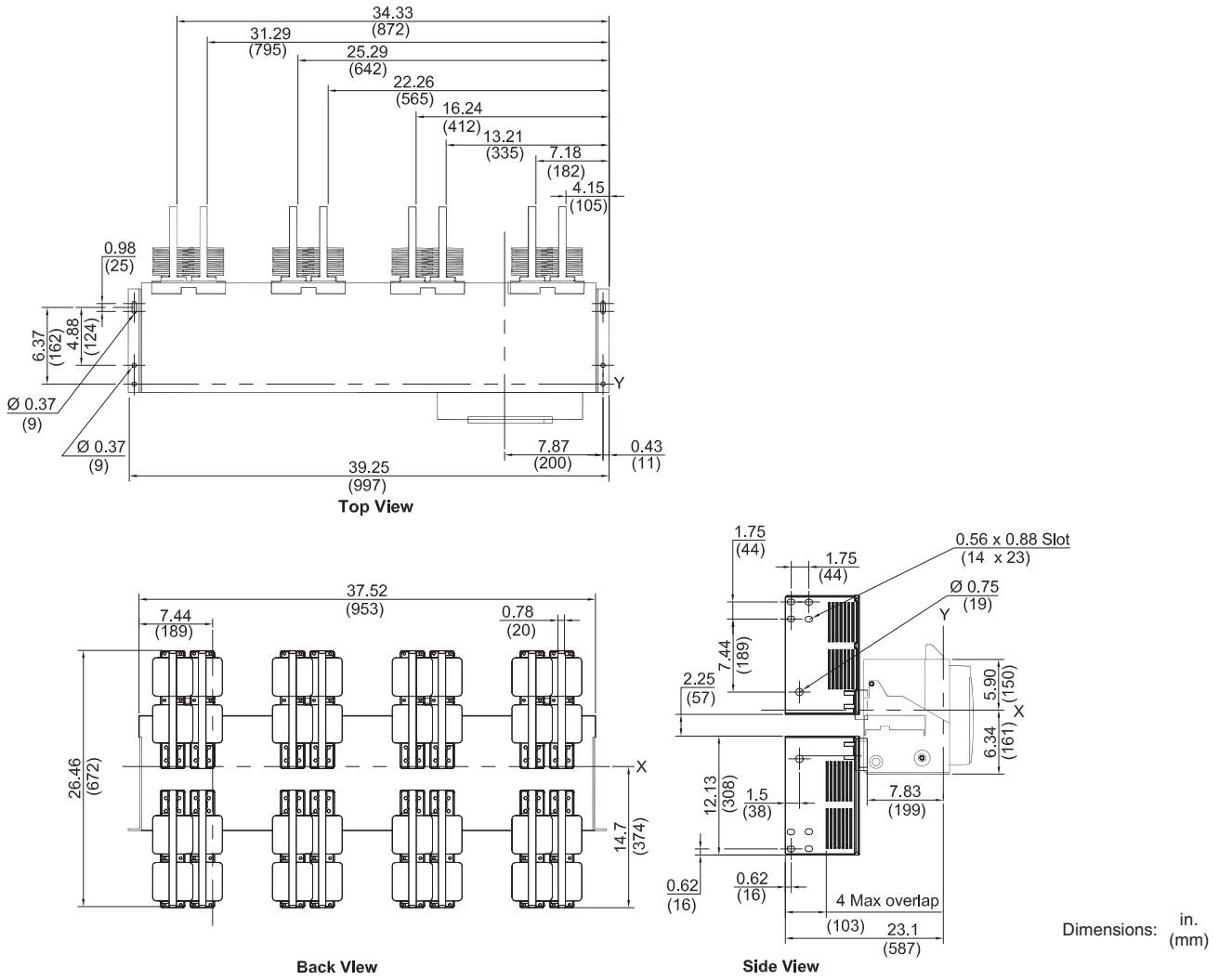

# Masterpact™ NT and NW Universal Power Circuit Breakers

## Masterpact NW Dimensional Drawings

Figure 132: Pan Drawings for Three-Pole and Four-Pole Circuit Breakers

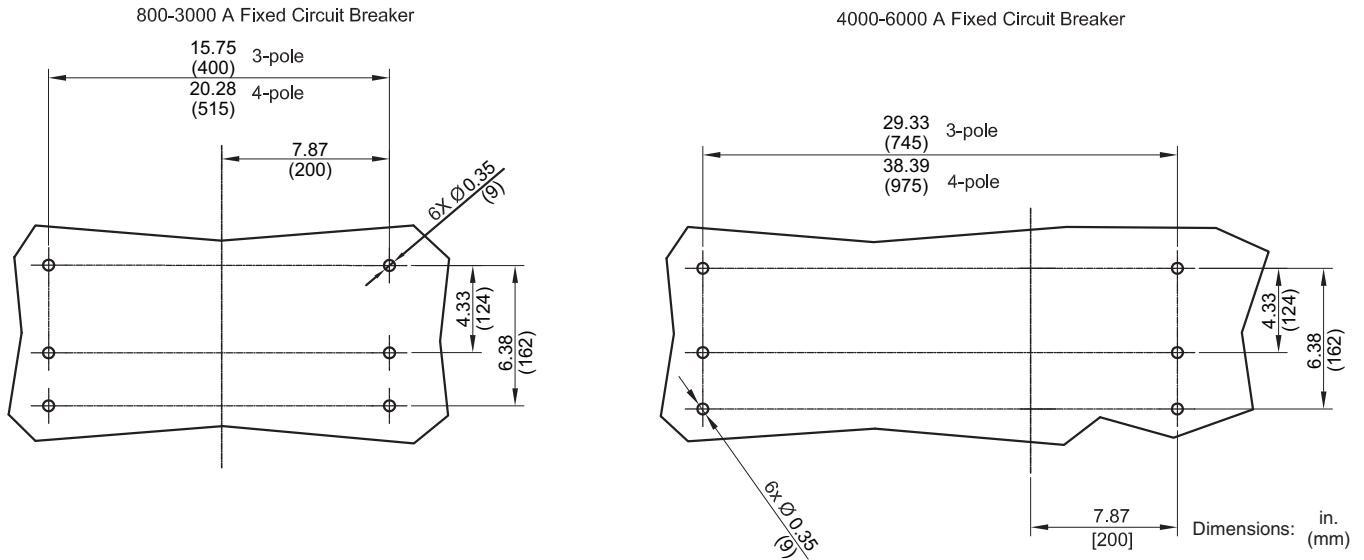

## Neutral Current Transformers

Figure 133: Neutral Current Transformer 100–1600 A, 2000–4000 A

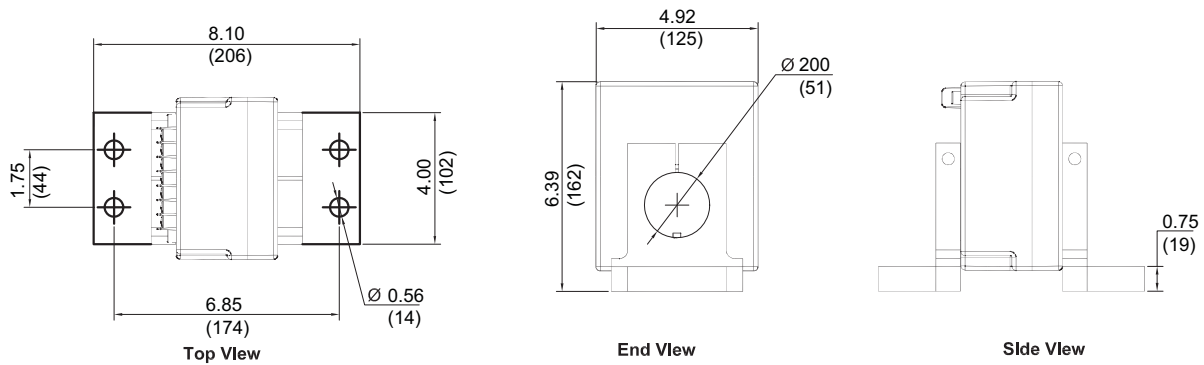
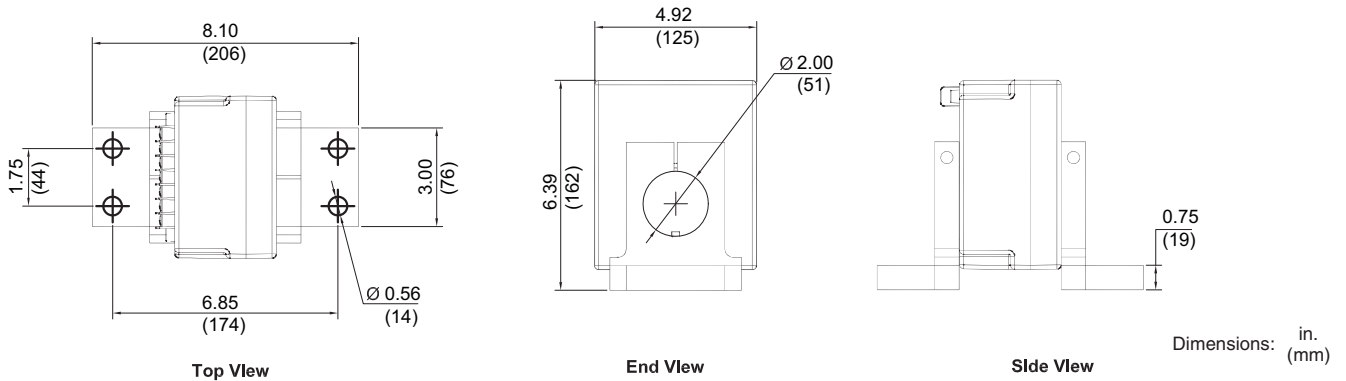

# Masterpact™ NT and NW Universal Power Circuit Breakers

## Masterpact NW Dimensional Drawings

Figure 134: Neutral Current Transformer 2000–4000 A

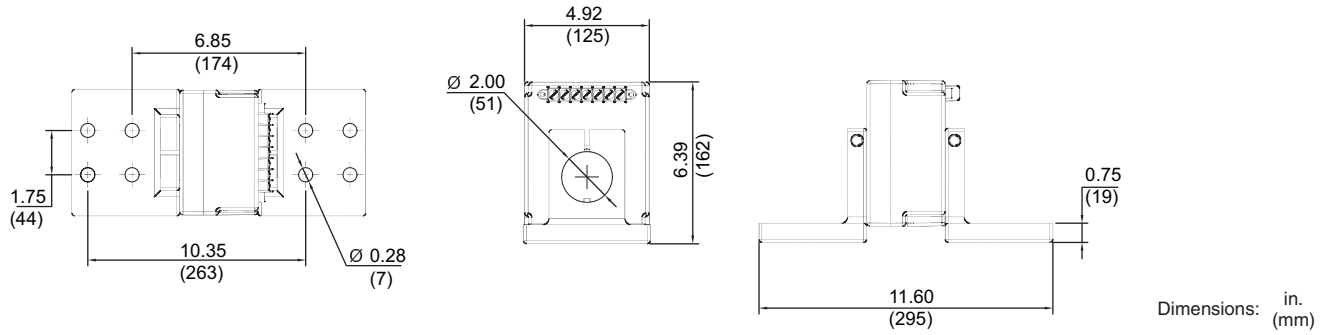
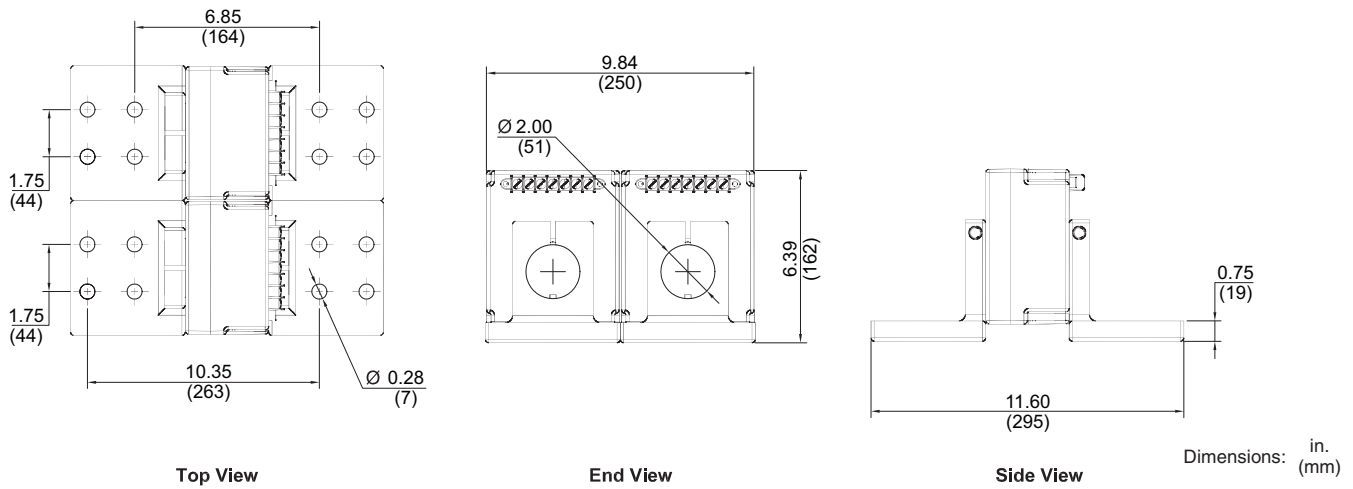

Figure 135: Double Neutral Current Transformer 2000–6300 A





**Masterpact™ NT and NW Universal Power Circuit Breakers**  
**Masterpact NW Dimensional Drawings**

**IEC Three-Pole Drawout Circuit Breakers\***

**Figure 137: 800–3200 A Rear-Connected "T" Vertical (RCTV)**

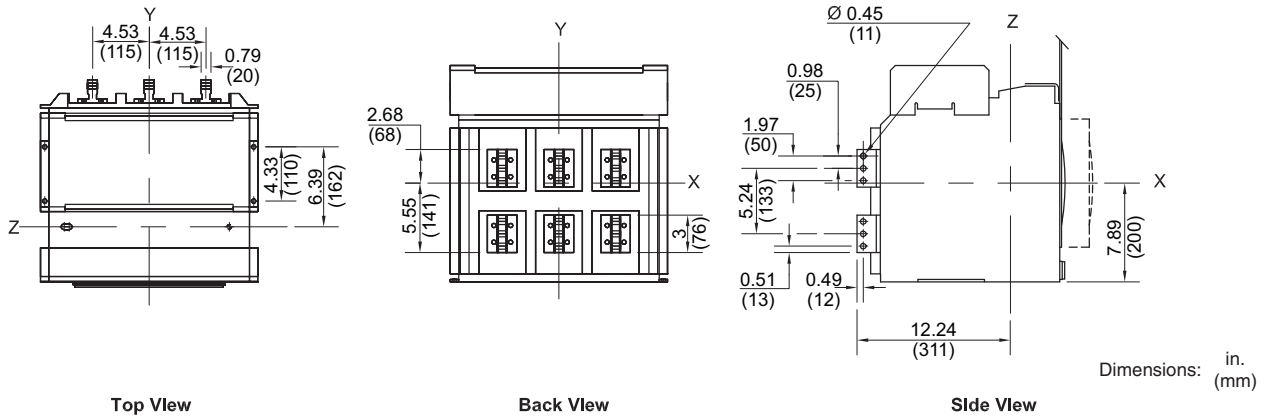

**Figure 138: 800–3200 A Rear-Connected "T" Horizontal (RCH)**

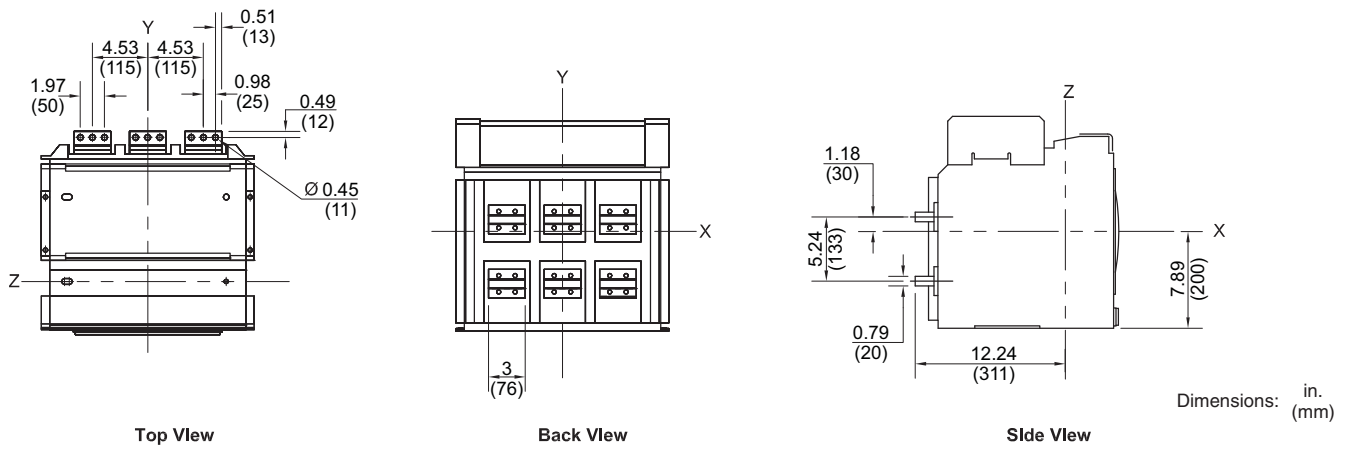

**Figure 139: 800–3200 A Front-Connected Flat (FCF)**

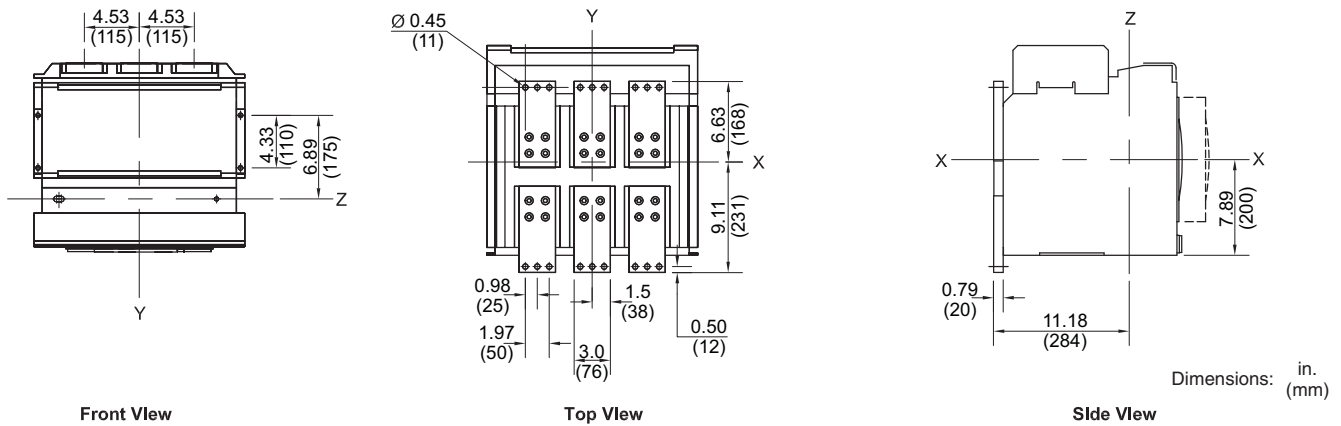



# Masterpact™ NT and NW Universal Power Circuit Breakers

## Masterpact NW Dimensional Drawings

Figure 142: 5000 A Rear-Connected "T" Vertical (RCTV)

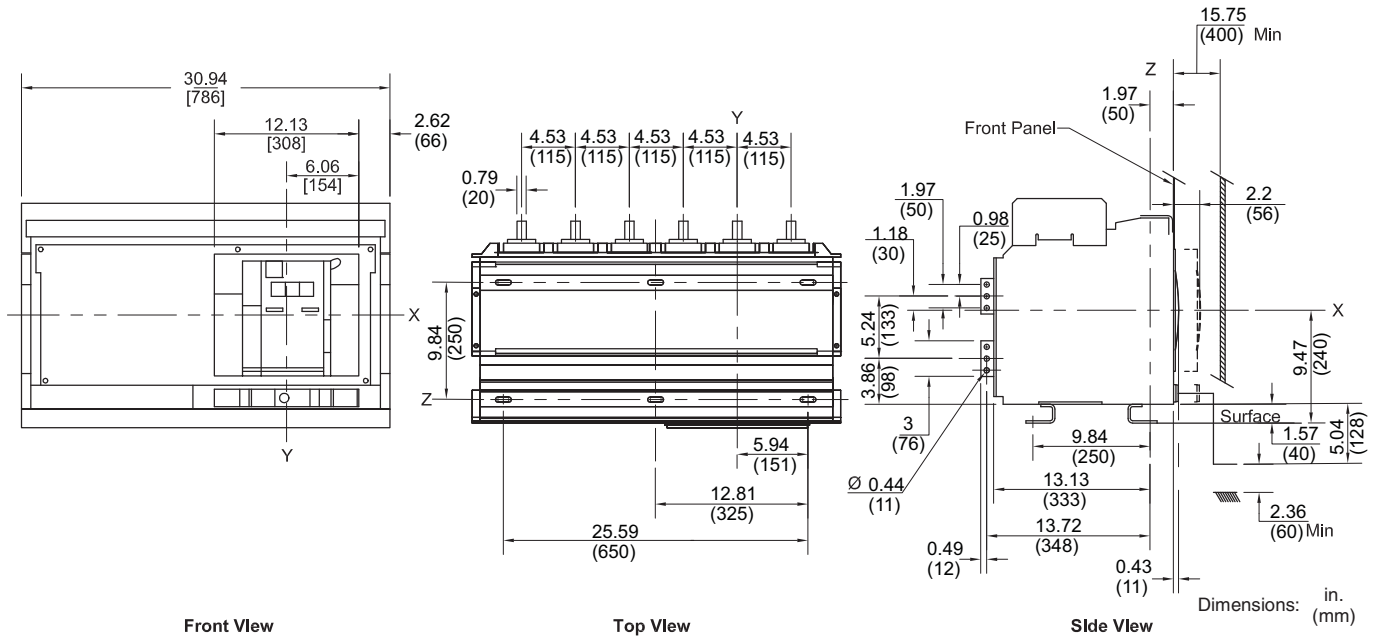



# Masterpact™ NT and NW Universal Power Circuit Breakers

## Masterpact NW Dimensional Drawings

Figure 143: 5000 A Rear-Connected "T" Horizontal (RCTH)

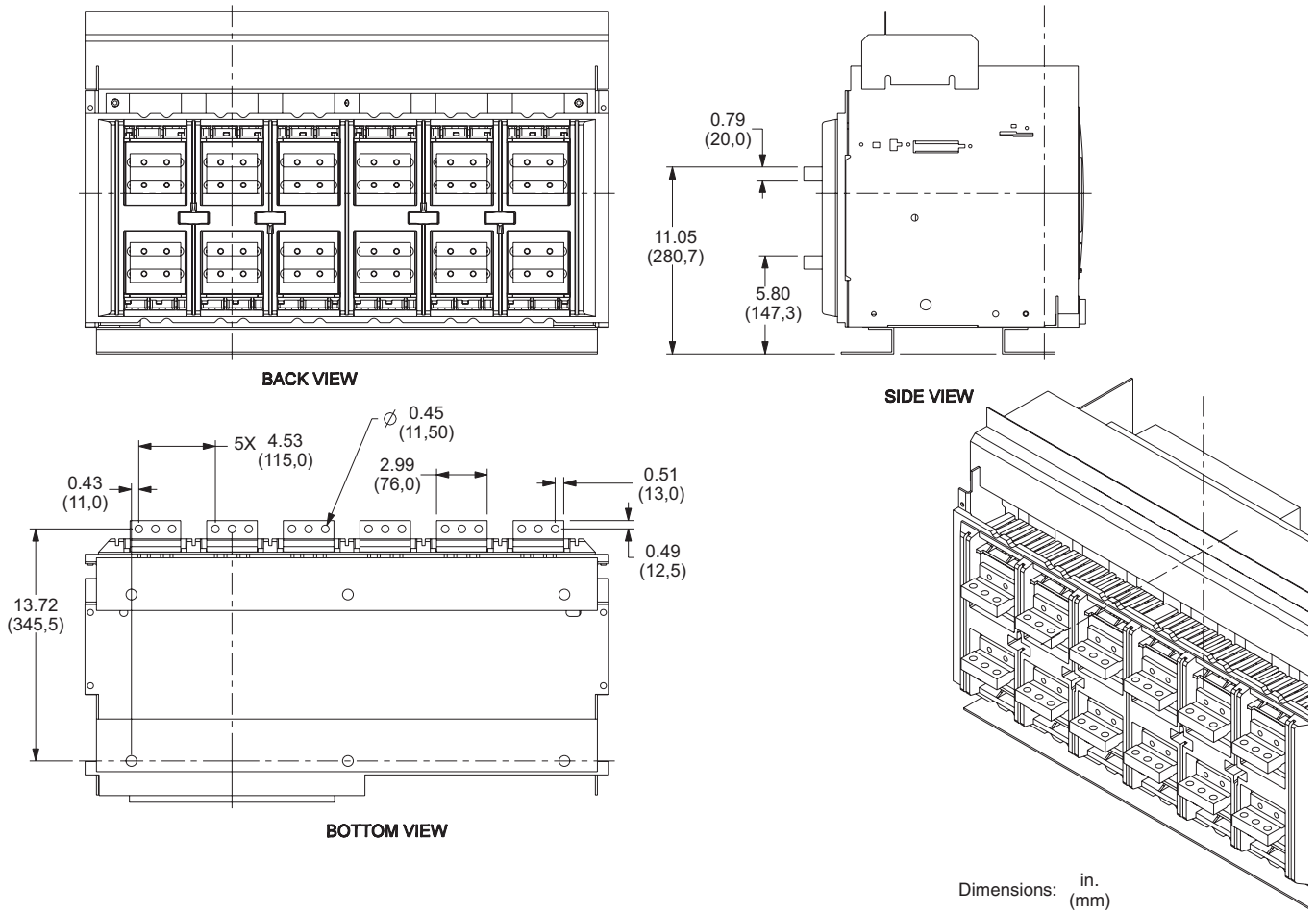

# Masterpact™ NT and NW Universal Power Circuit Breakers

## Masterpact NW Dimensional Drawings

Figure 144: 6300 A Rear-Connected "T" Vertical (RCTV)

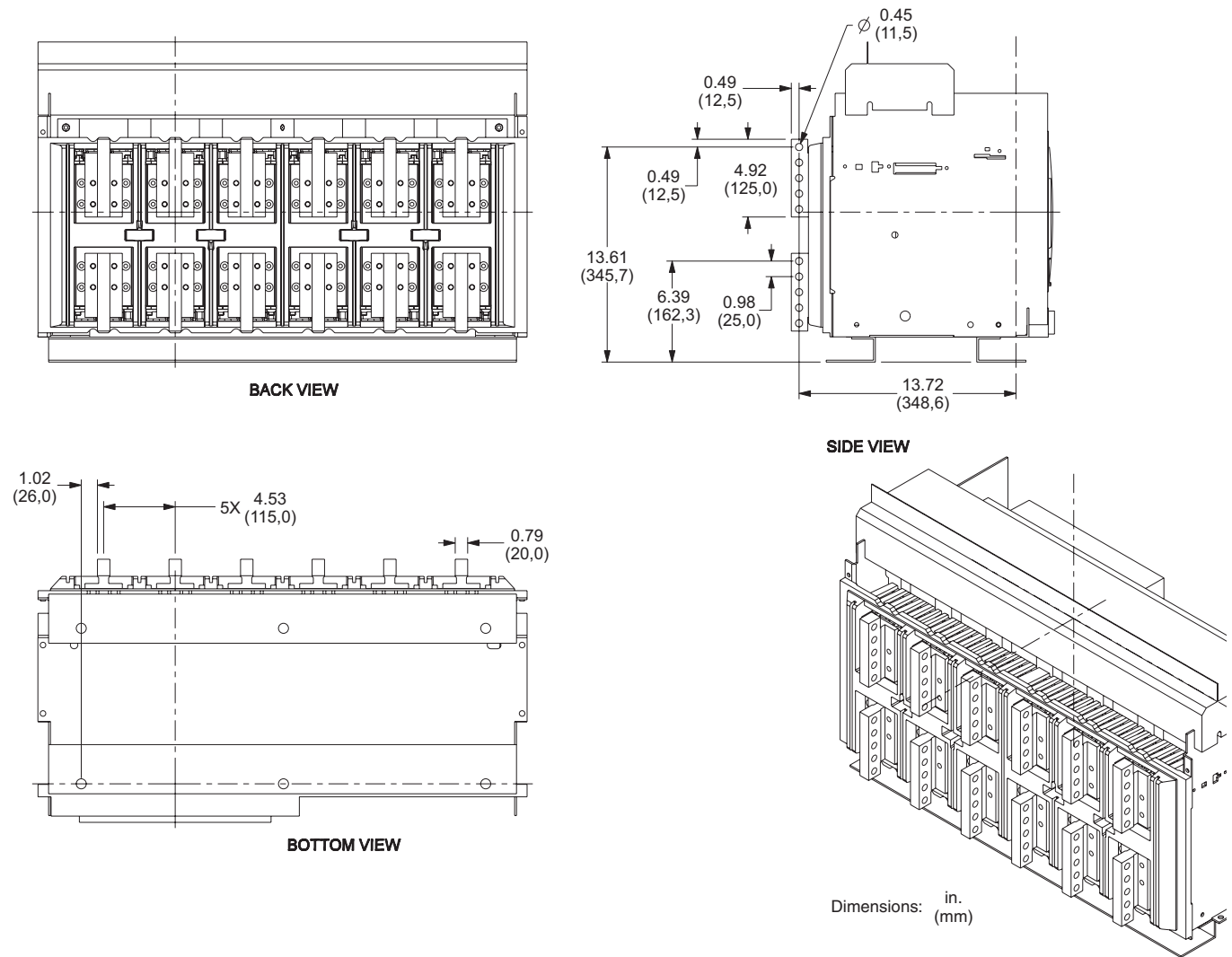

# Masterpact™ NT and NW Universal Power Circuit Breakers

## Masterpact NW Dimensional Drawings

### IEC Three-Pole Fixed Circuit Breakers

**Figure 145: 800–3200 A Rear-Connected "T" Vertical (RCTV)**

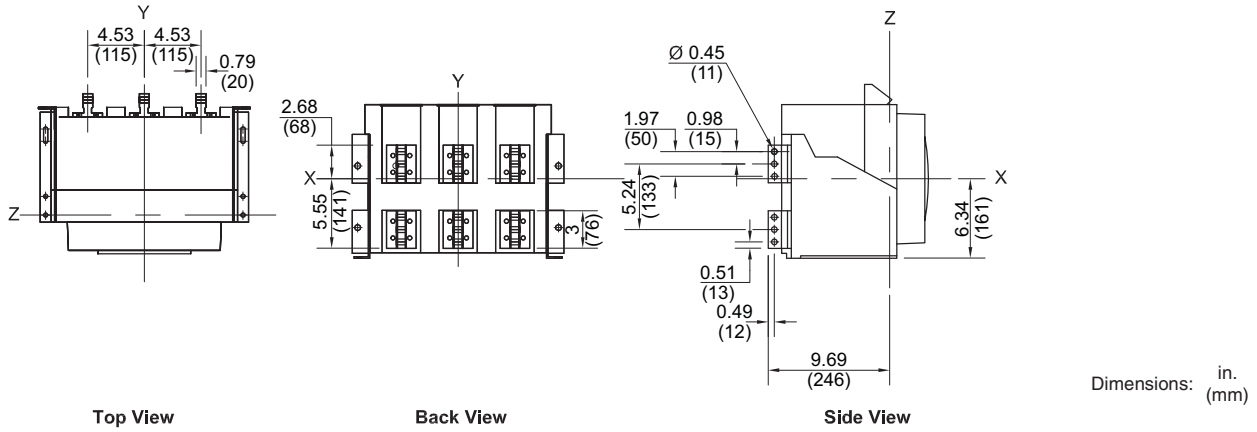

**Figure 146: 800–3200 A Rear-Connected "T" Horizontal (RCTH)**

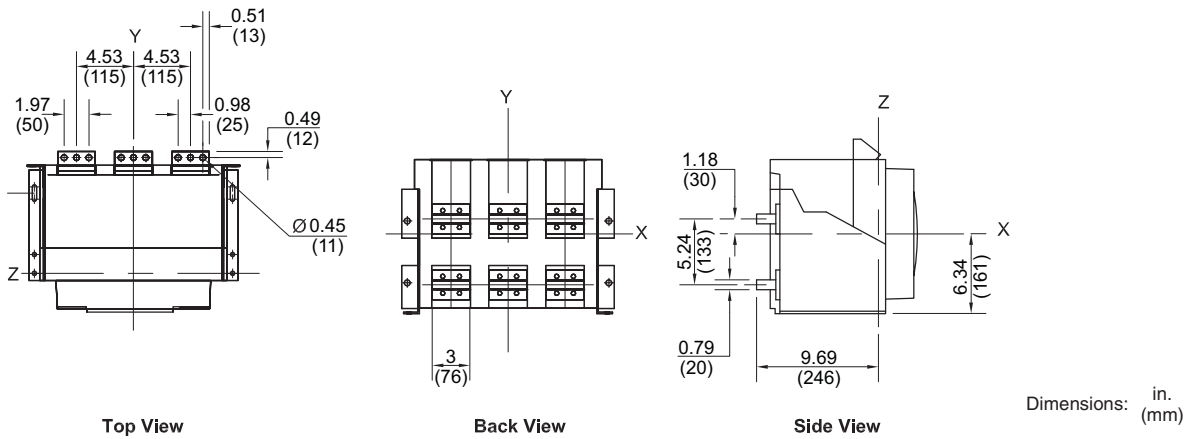

**Figure 147: 800–3200 A Front-Connected Flat (FCF)**

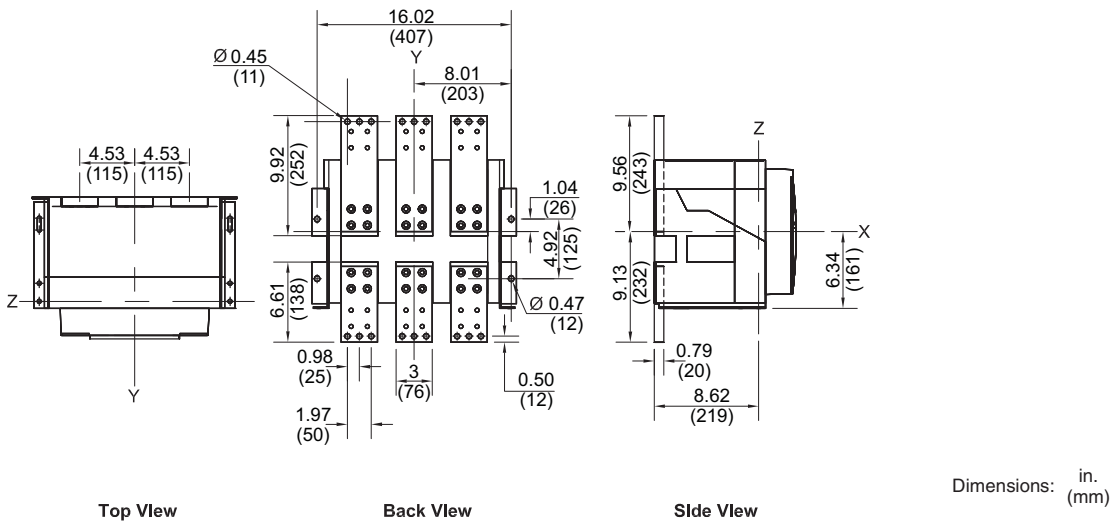

# Masterpact™ NT and NW Universal Power Circuit Breakers

## Masterpact NW Dimensional Drawings

Figure 148: 4000 A Rear-Connected "T" Vertical (RCTV)

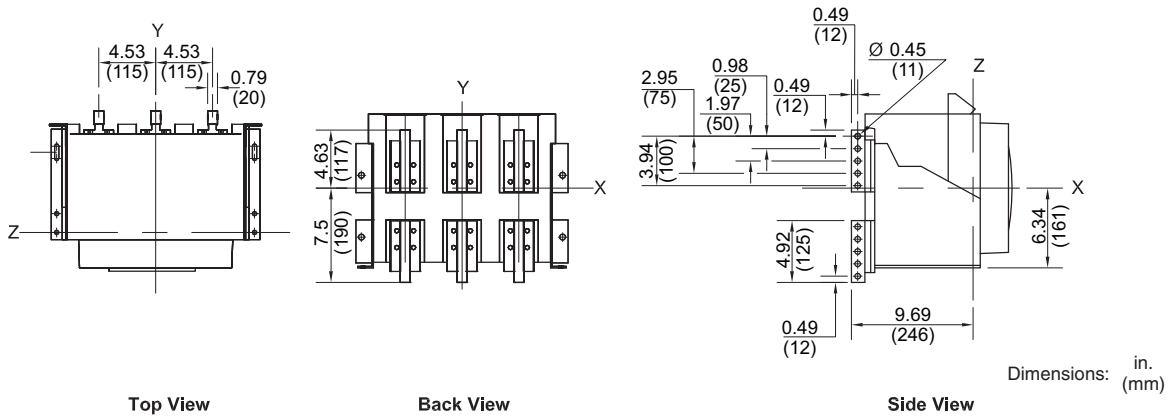

# Masterpact™ NT and NW Universal Power Circuit Breakers

## Masterpact NW Dimensional Drawings

Figure 150: 5000 A Rear-Connected "T" Vertical (RCTV)

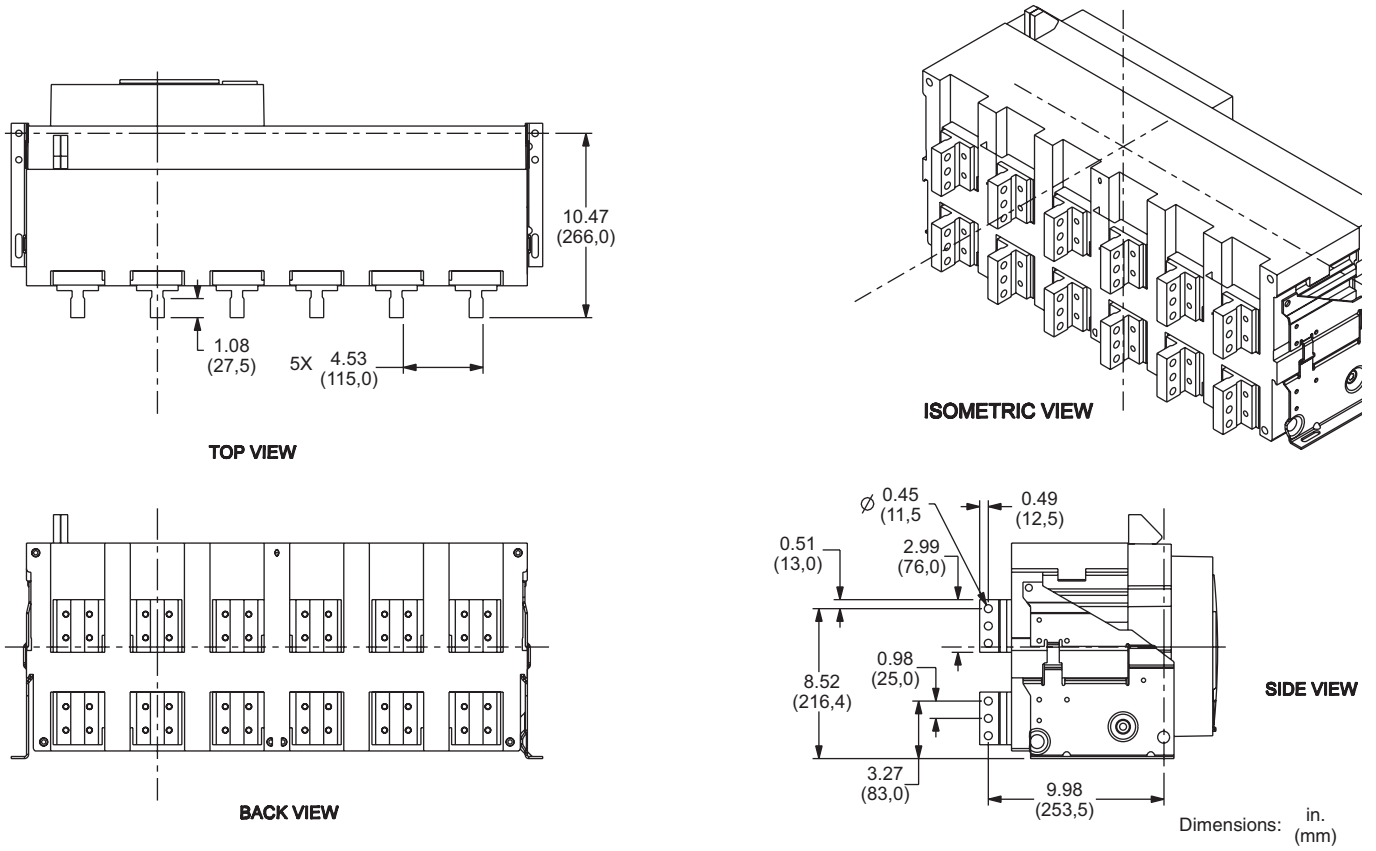

# Masterpact™ NT and NW Universal Power Circuit Breakers

## Masterpact NW Dimensional Drawings

Figure 151: 5000 A Rear-Connected "T" Horizontal (RCHT)

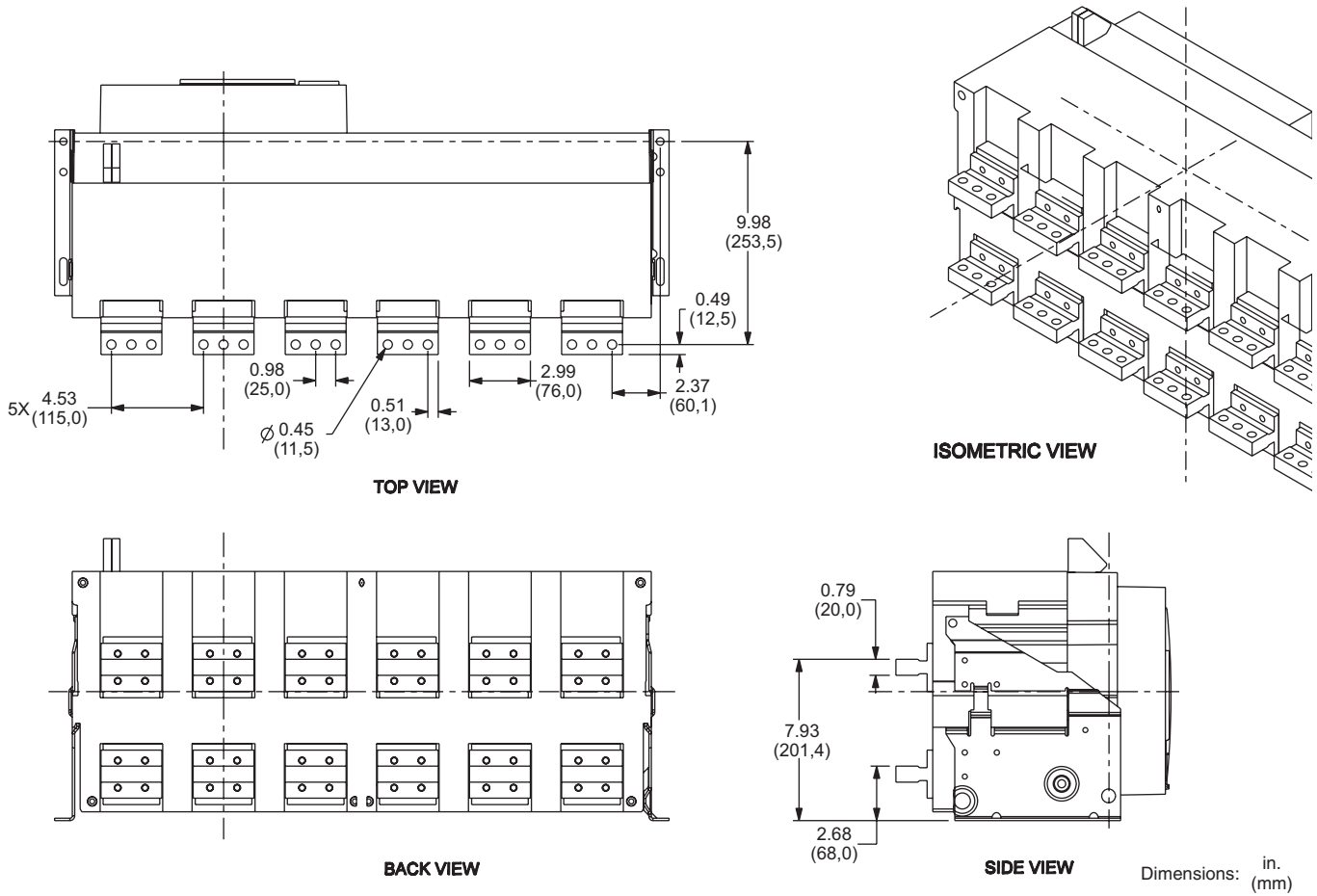

# Masterpact™ NT and NW Universal Power Circuit Breakers

## Masterpact NW Dimensional Drawings

Figure 152: 6300 A Rear-Connected "T" Vertical (RCTV)

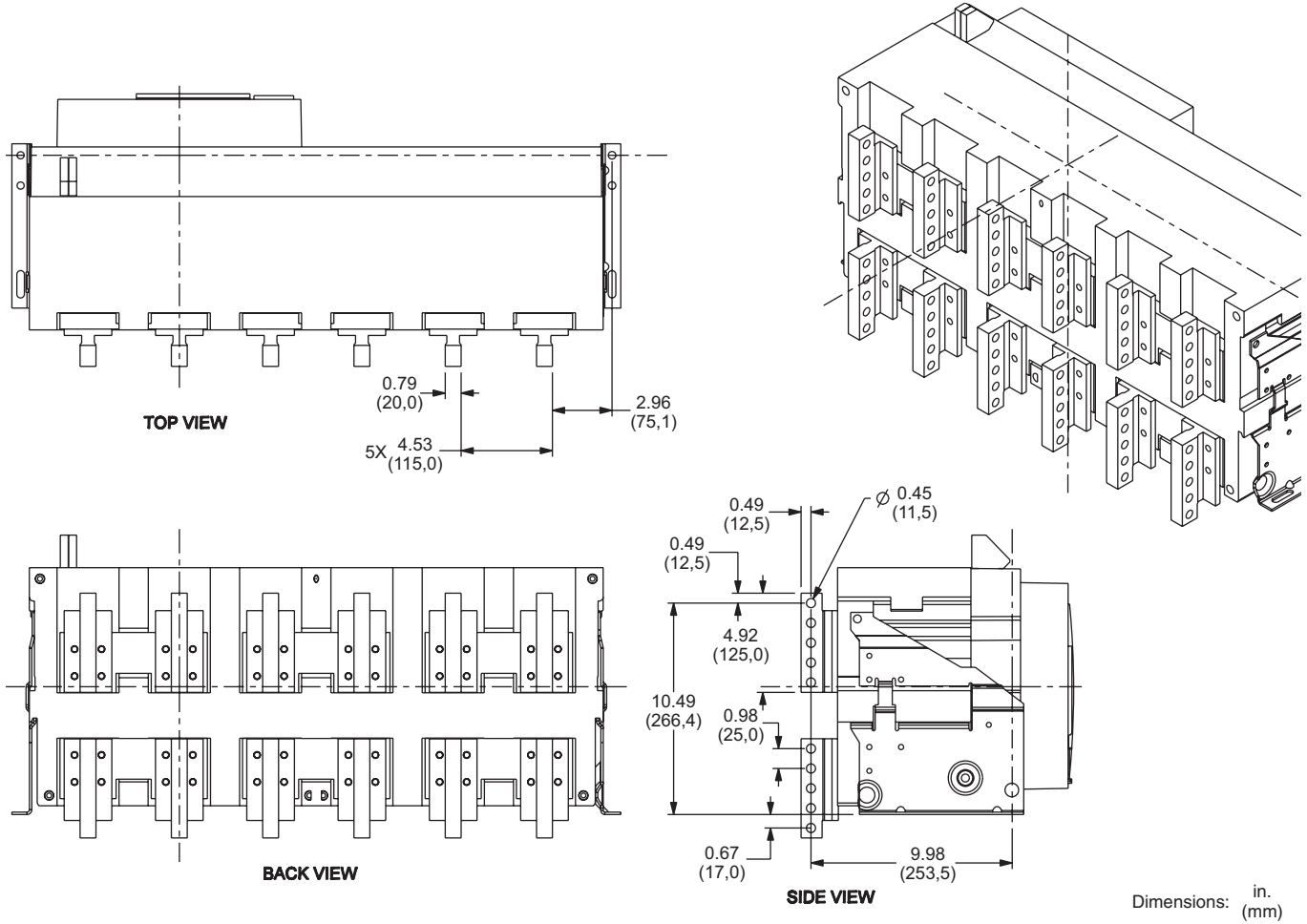

## IEC Four-Pole Drawout Circuit Breakers

Figure 153: 800–3200 A Rear-Connected "T" Vertical (RCTV)

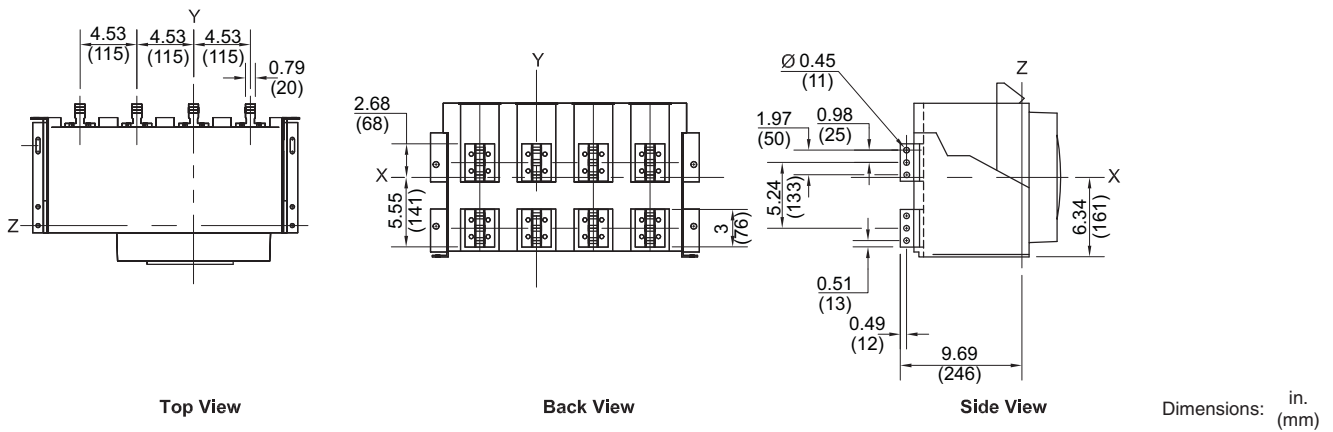

# Masterpact™ NT and NW Universal Power Circuit Breakers

## Masterpact NW Dimensional Drawings

Figure 154: 800–3200 A Rear-Connected "T" Horizontal (RCTH)

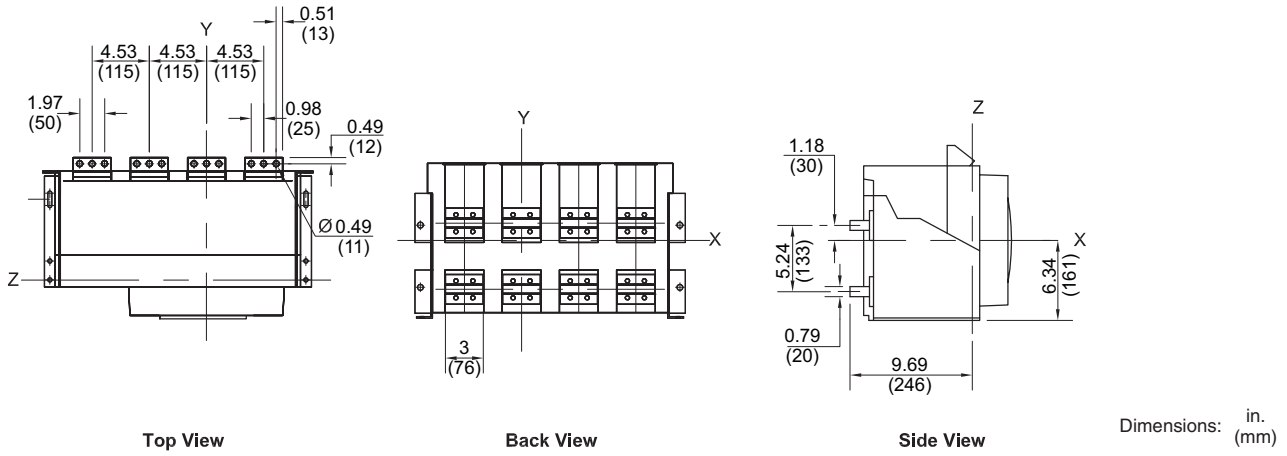

Figure 155: 800–3200 A Front-Connected Flat (FCF)

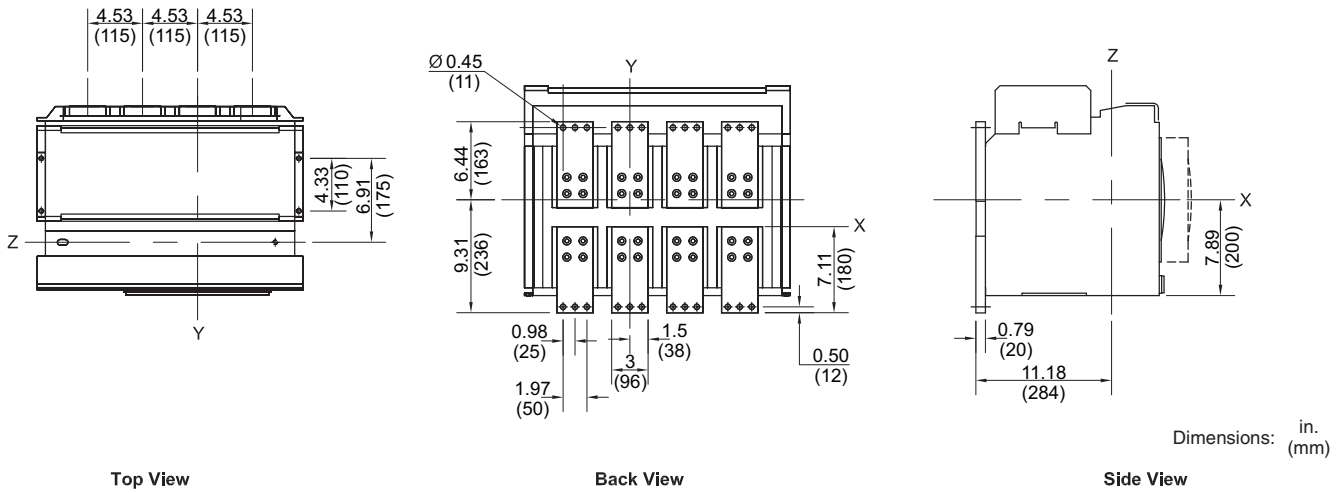
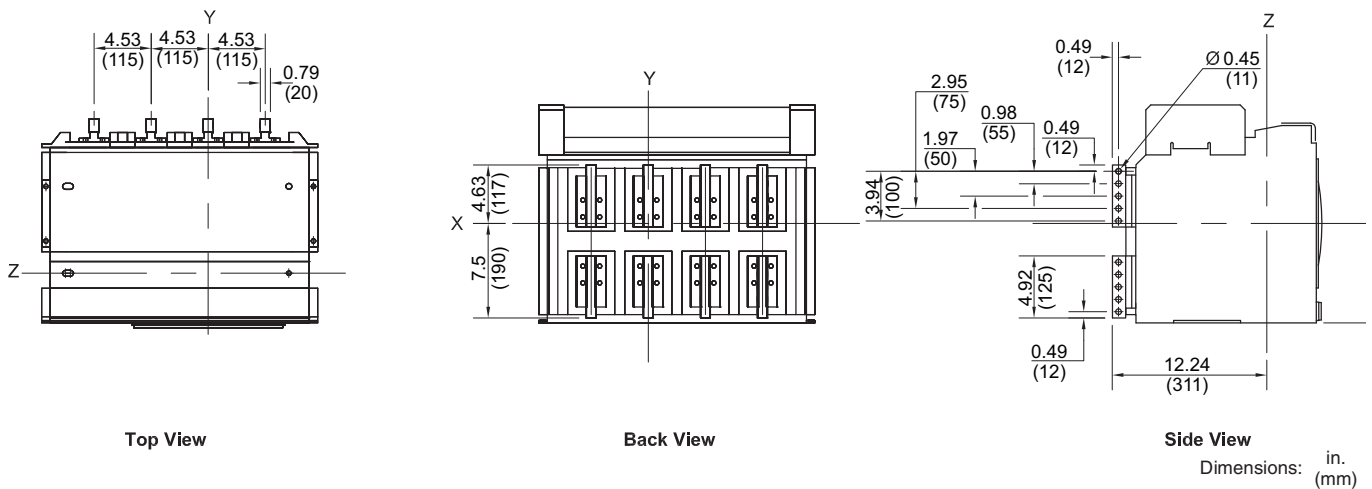

Figure 156: 4000 A Rear-Connected "T" Vertical (RCTV)





# Masterpact™ NT and NW Universal Power Circuit Breakers

## Masterpact NW Dimensional Drawings

**Figure 157: 4000 A Rear-Connected "T" Horizontal (RCTH)**

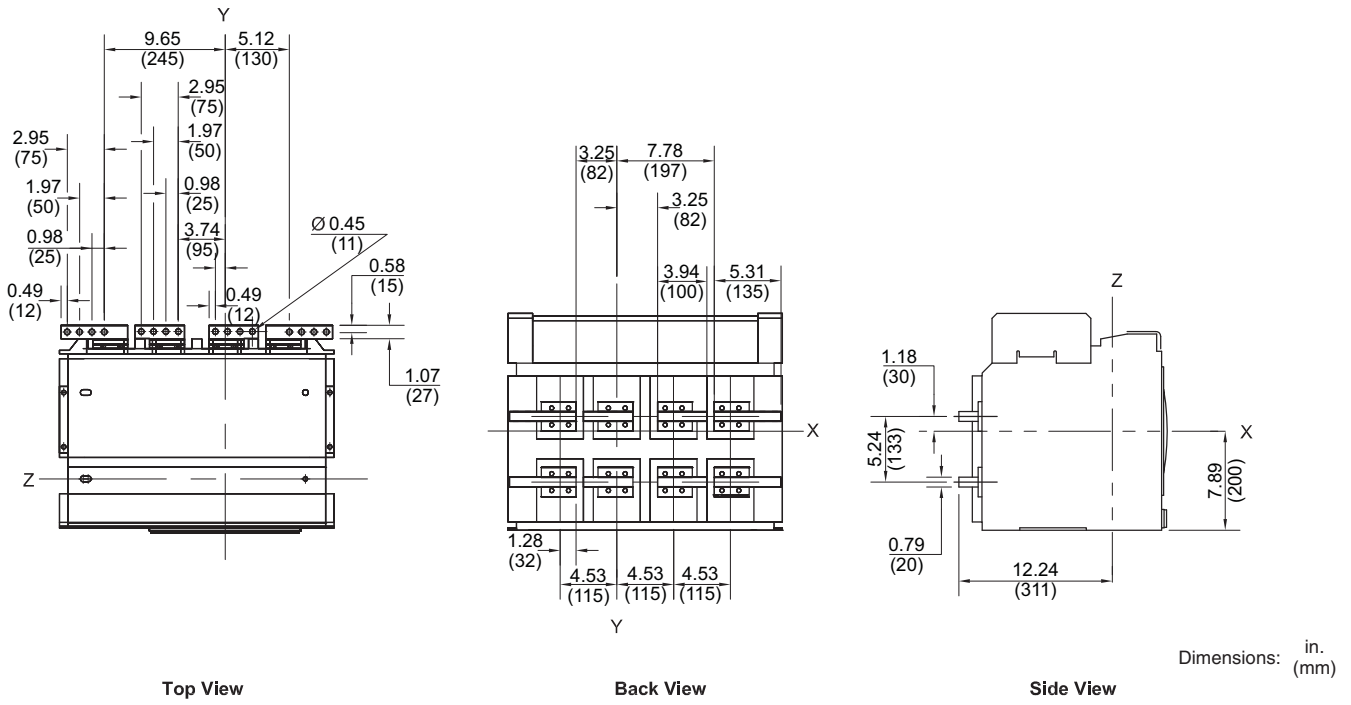

# Masterpact™ NT and NW Universal Power Circuit Breakers

## Masterpact NW Dimensional Drawings

Figure 158: 5000 A Rear-Connected “T” Vertical (RCTV)

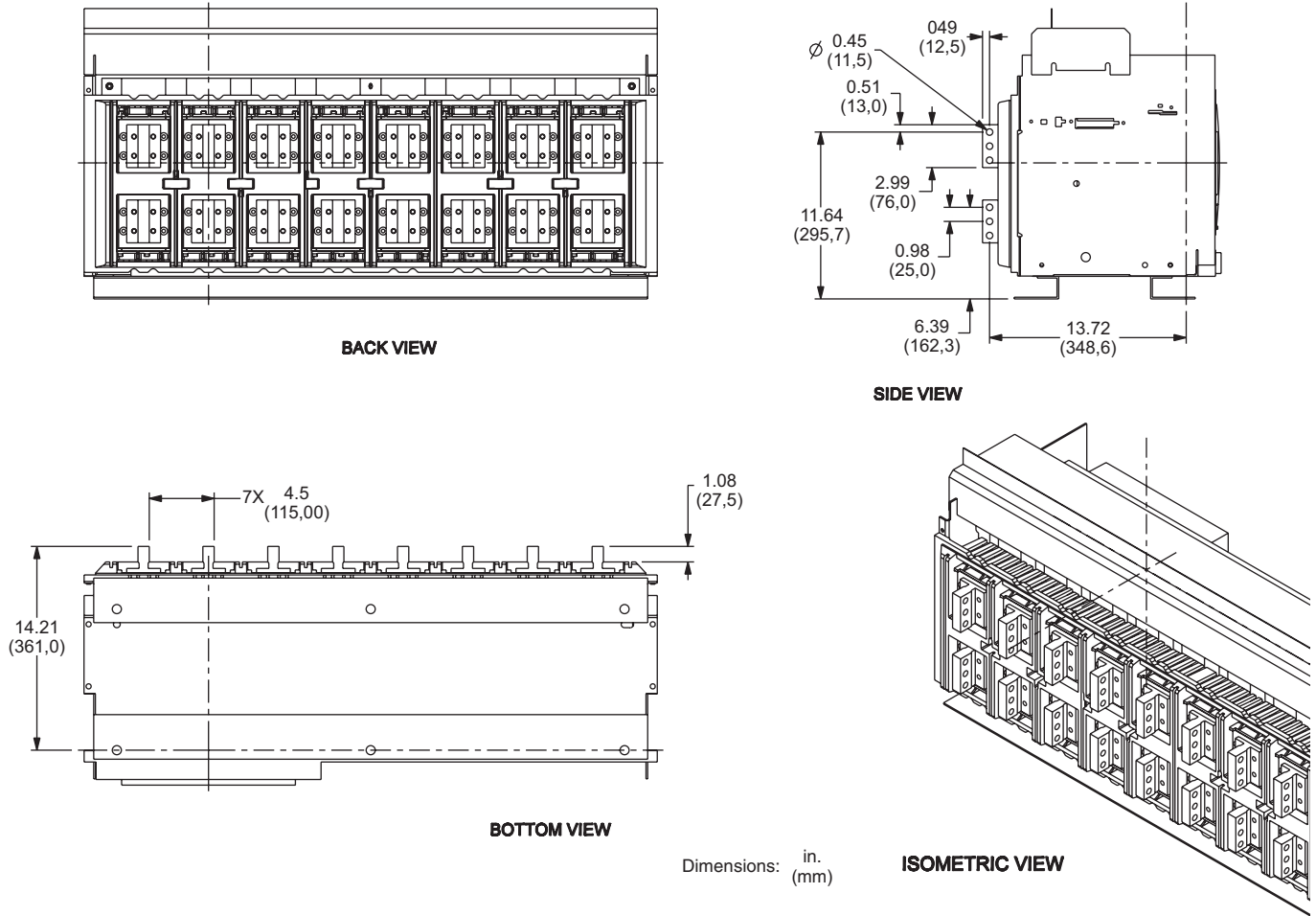

# Masterpact™ NT and NW Universal Power Circuit Breakers

## Masterpact NW Dimensional Drawings

Figure 159: 5000 A Rear-Connected “T” Horizontal (RCH)

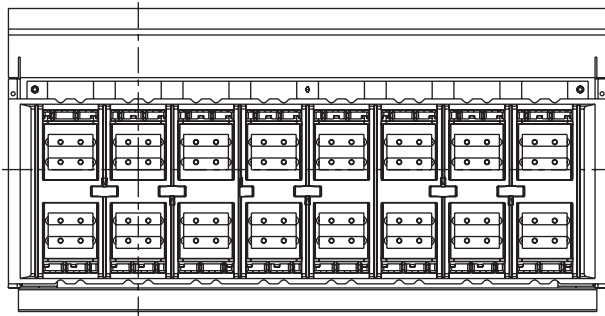

BACK VIEW

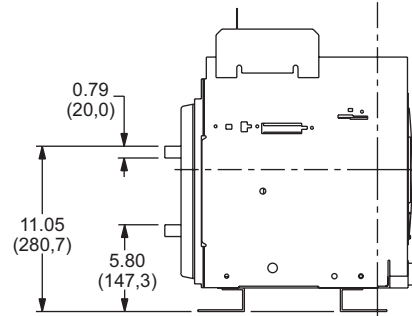

SIDE VIEW

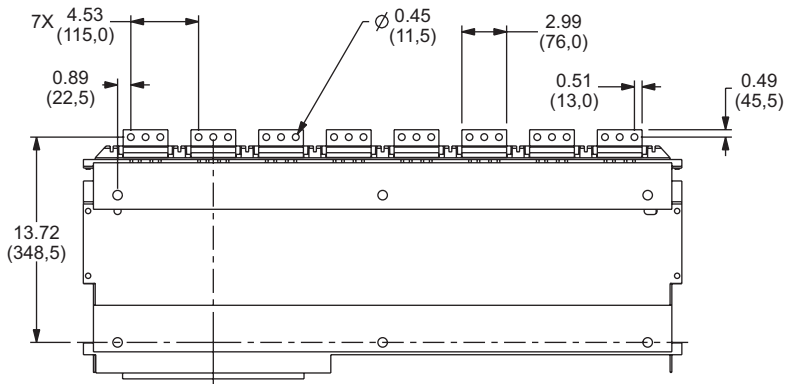

BOTTOM VIEW

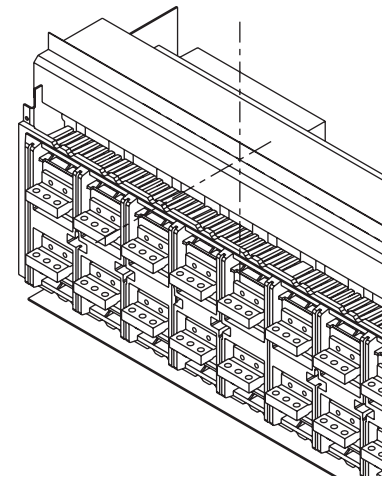

Dimensions: in.  
(mm)

# Masterpact™ NT and NW Universal Power Circuit Breakers

## Masterpact NW Dimensional Drawings

Figure 160: 6300 A Rear-Connected "T" Vertical (RCTV)

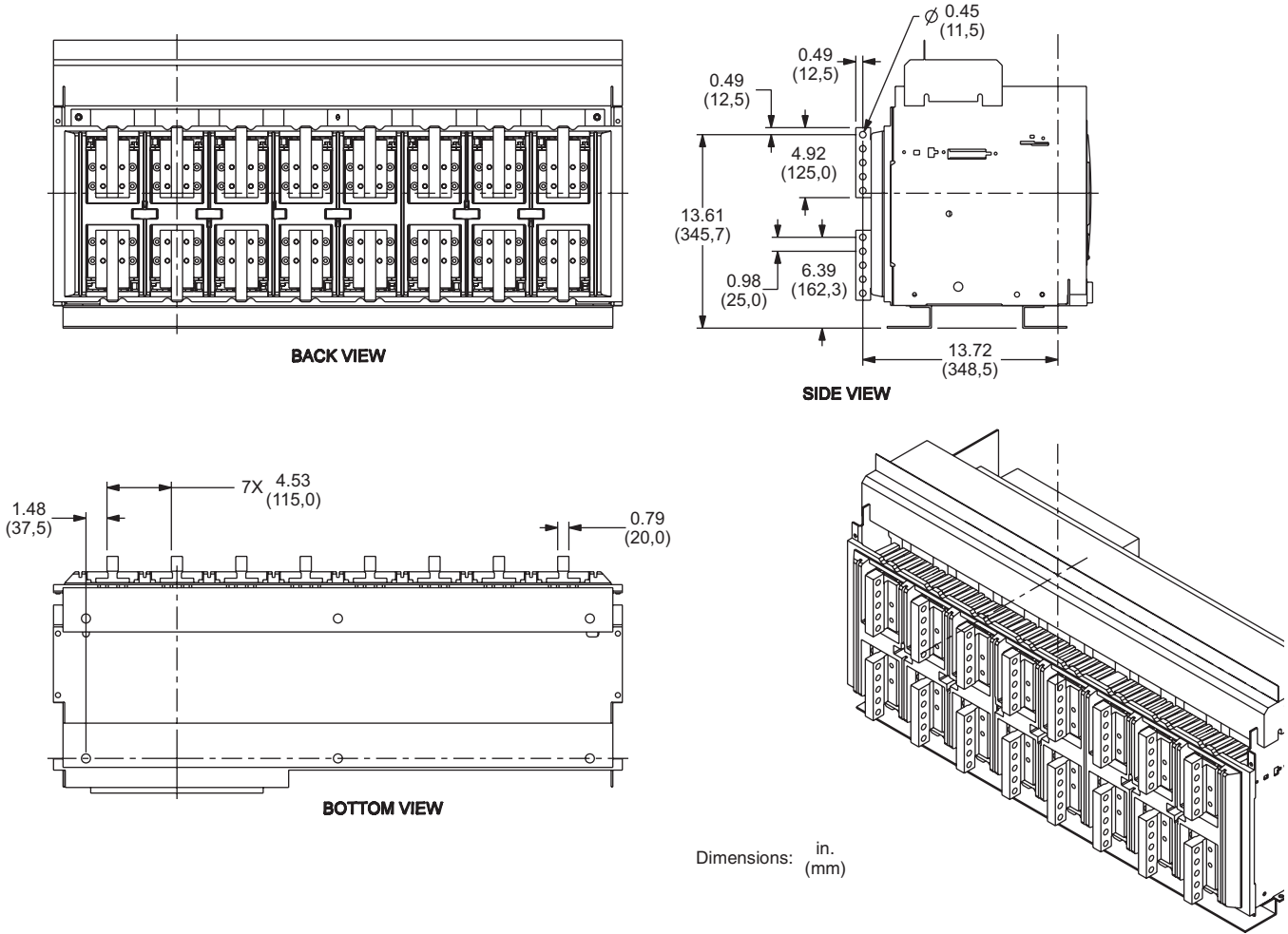

## IEC Four-Pole Fixed Circuit Breakers

Figure 161: 800–3200 A Rear-Connected "T" Vertical (RCTV)

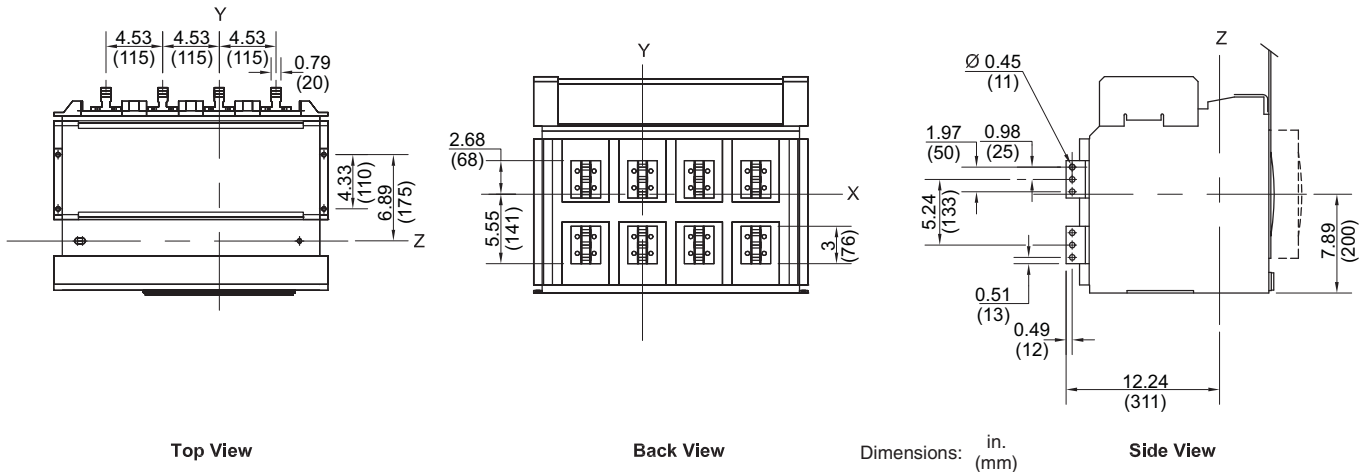

# Masterpact™ NT and NW Universal Power Circuit Breakers

## Masterpact NW Dimensional Drawings

**Figure 162: 800–3200 A Rear-Connected "T" Horizontal (RCTH)**

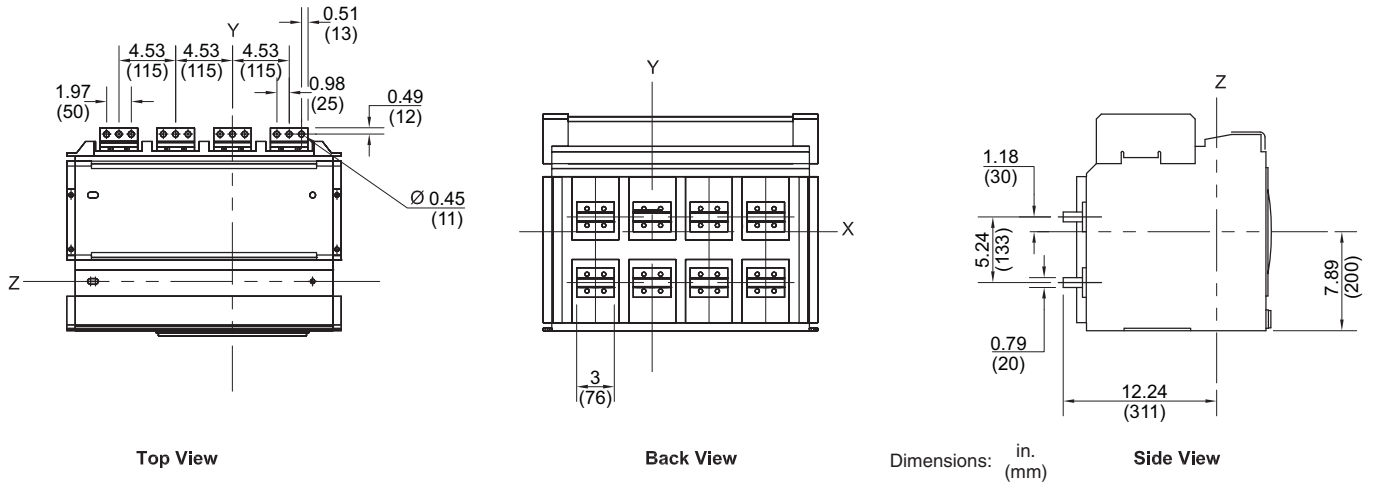

**Figure 163: 800–3200 A Front-Connected Flat (FCF)**

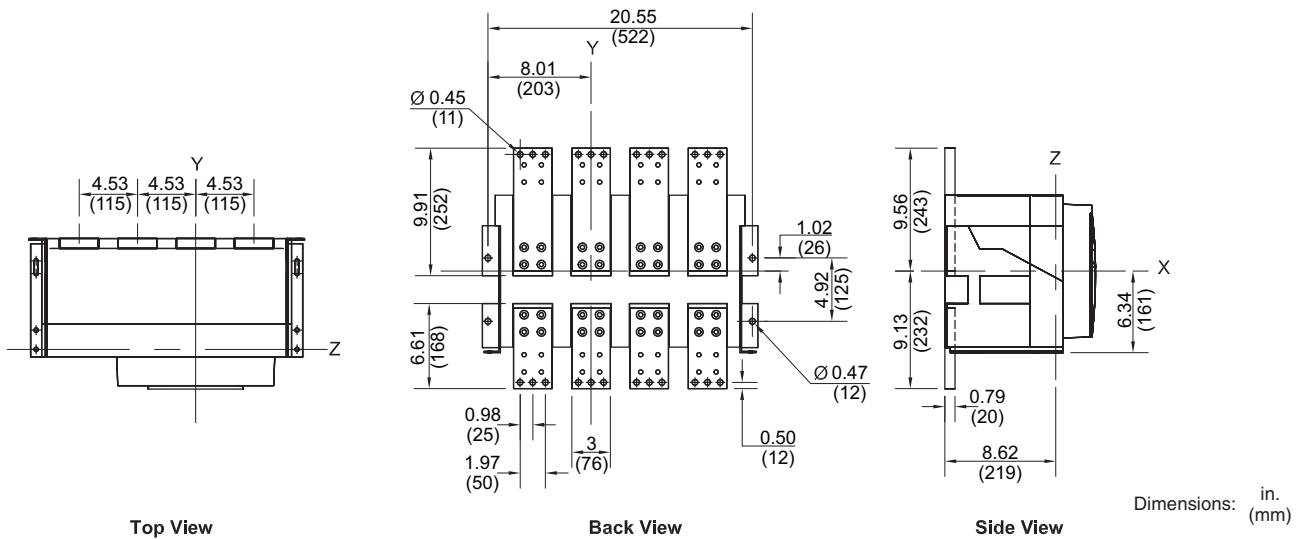

**Figure 164: 4000 A Rear-Connected "T" Vertical (RCTV)**

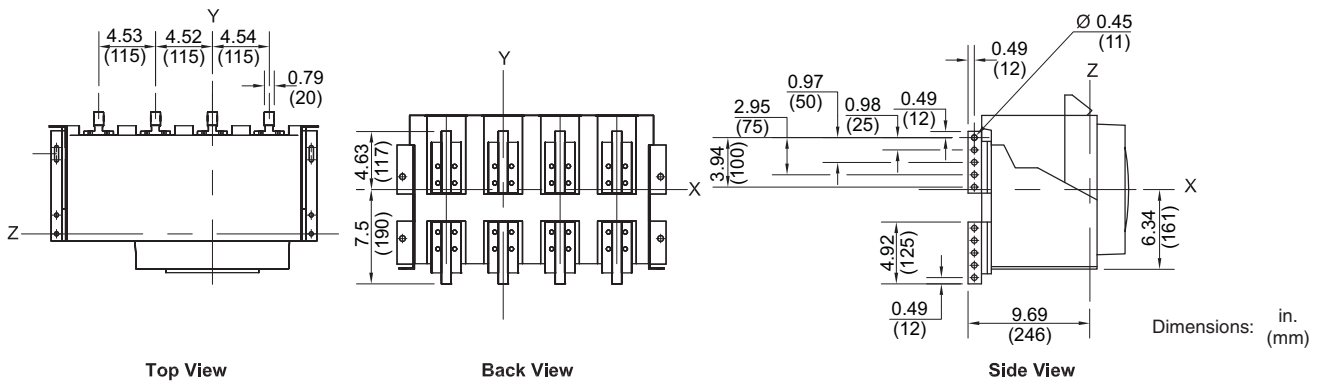

# Masterpact™ NT and NW Universal Power Circuit Breakers

## Masterpact NW Dimensional Drawings

Figure 165: 4000 A Rear-Connected "T" Horizontal (RCH)

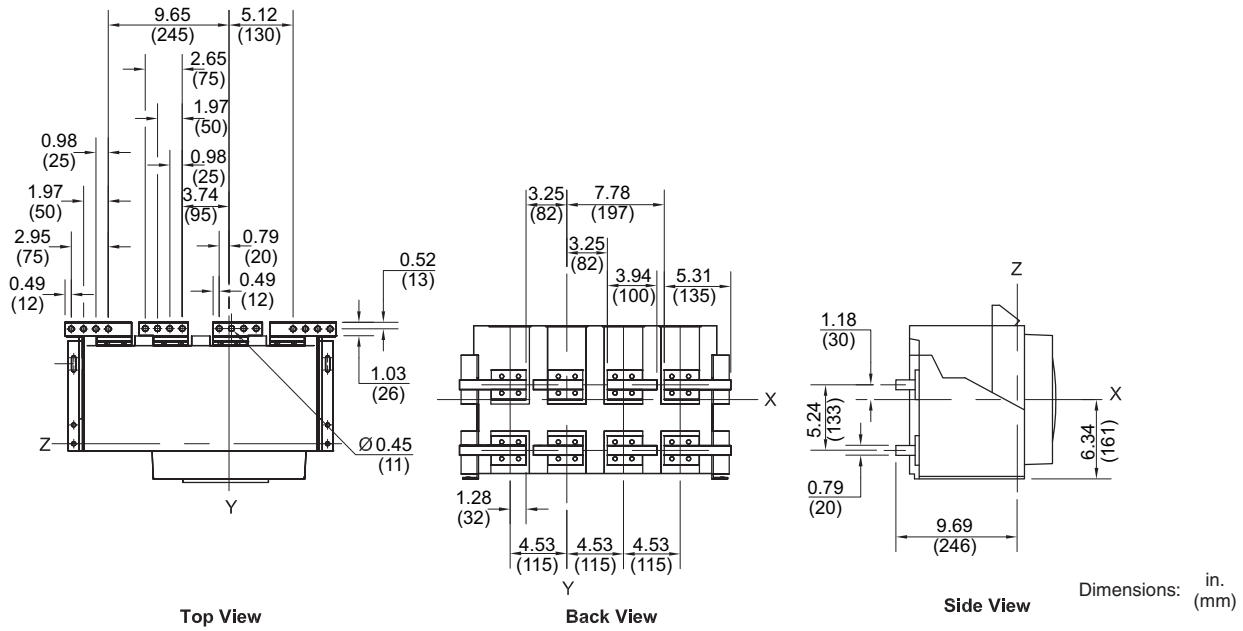
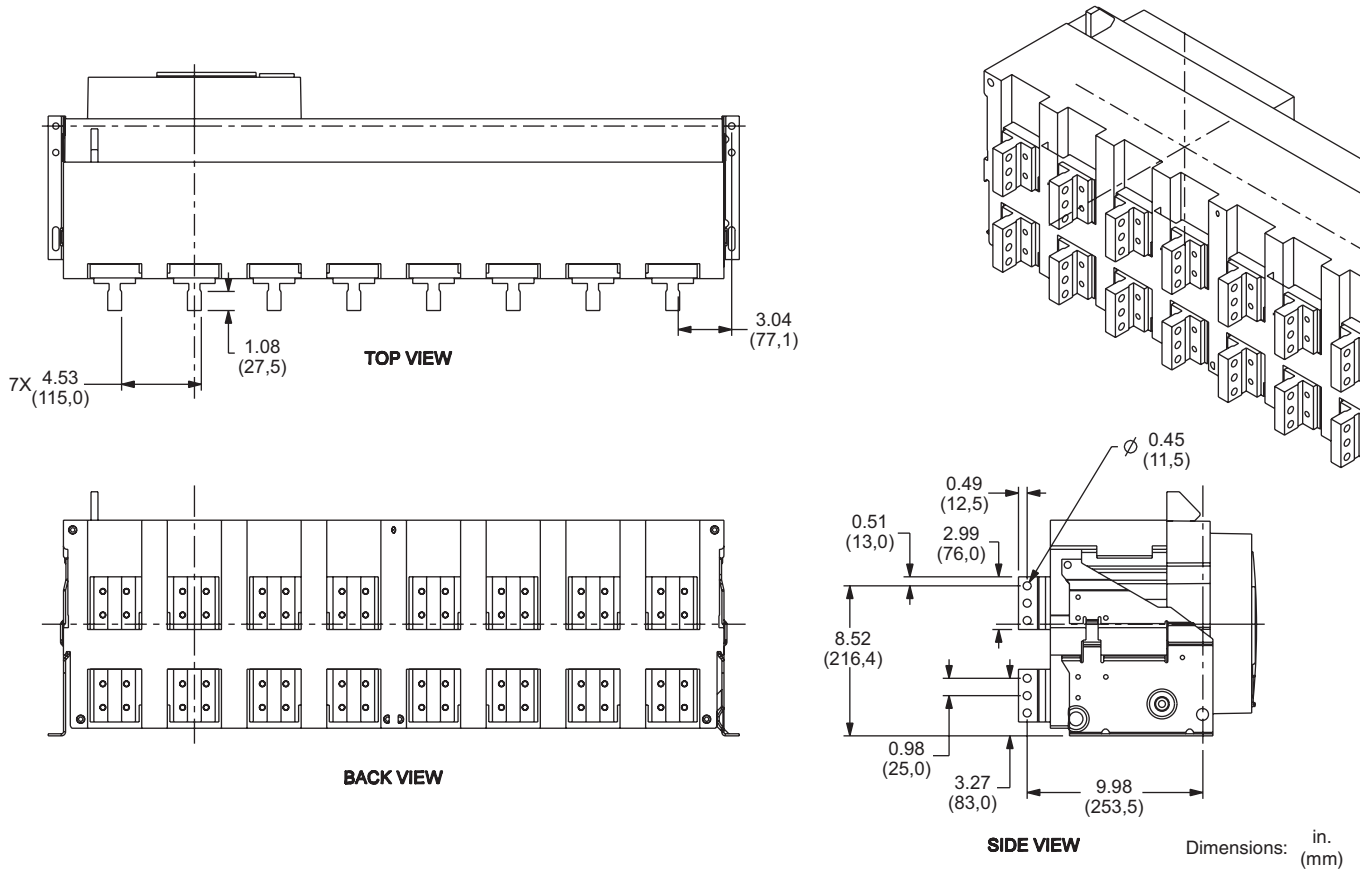

Figure 166: 5000 A Rear-Connected "T" Vertical (RCTV)



# Masterpact™ NT and NW Universal Power Circuit Breakers

## Masterpact NW Dimensional Drawings

Figure 167: 5000 A Rear-Connected “T” Horizontal (RCH)

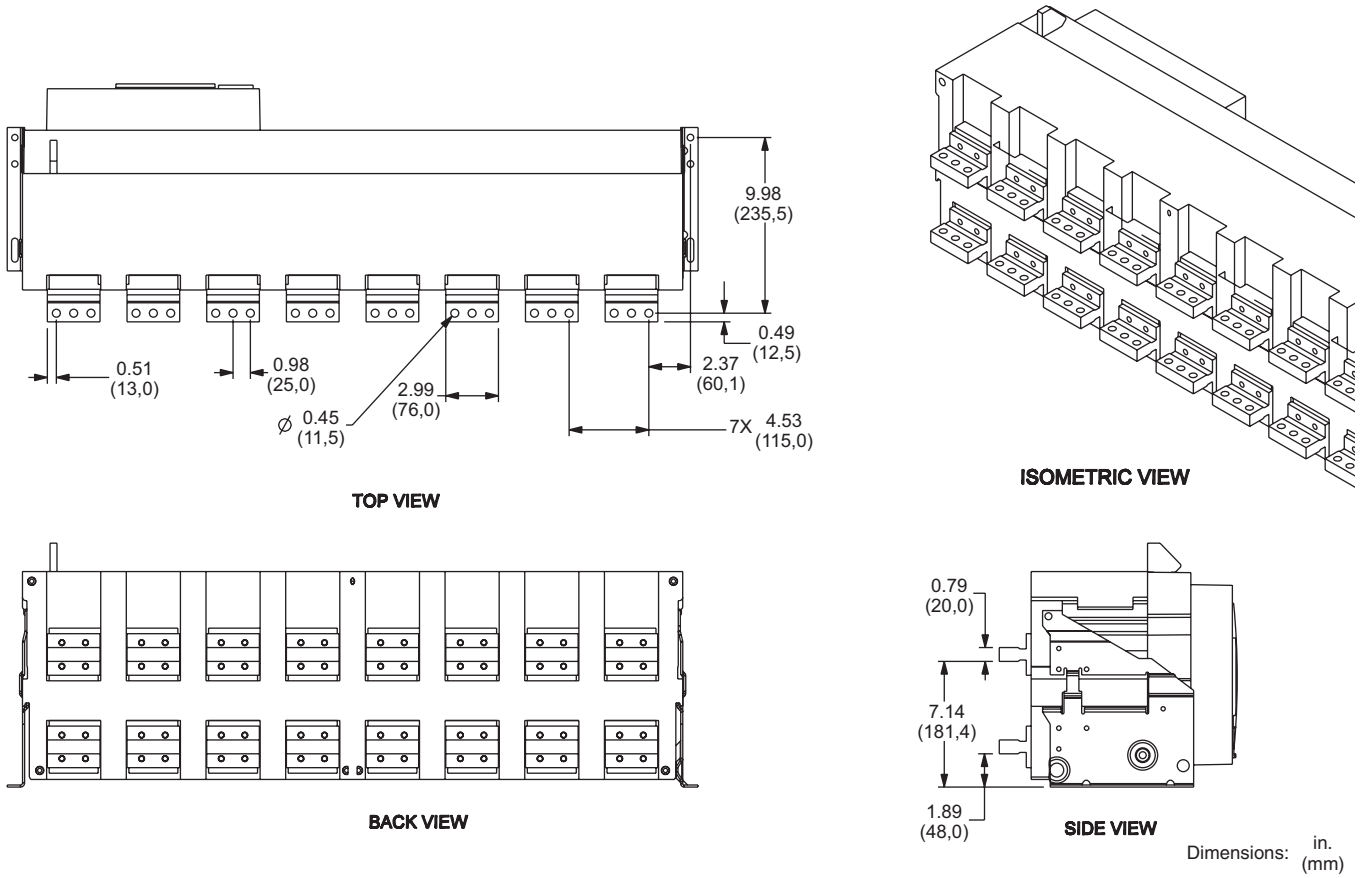

# Masterpact™ NT and NW Universal Power Circuit Breakers

## Masterpact NW Dimensional Drawings

Figure 168: 6300 Rear-Connected “T” Vertical (RCTV)

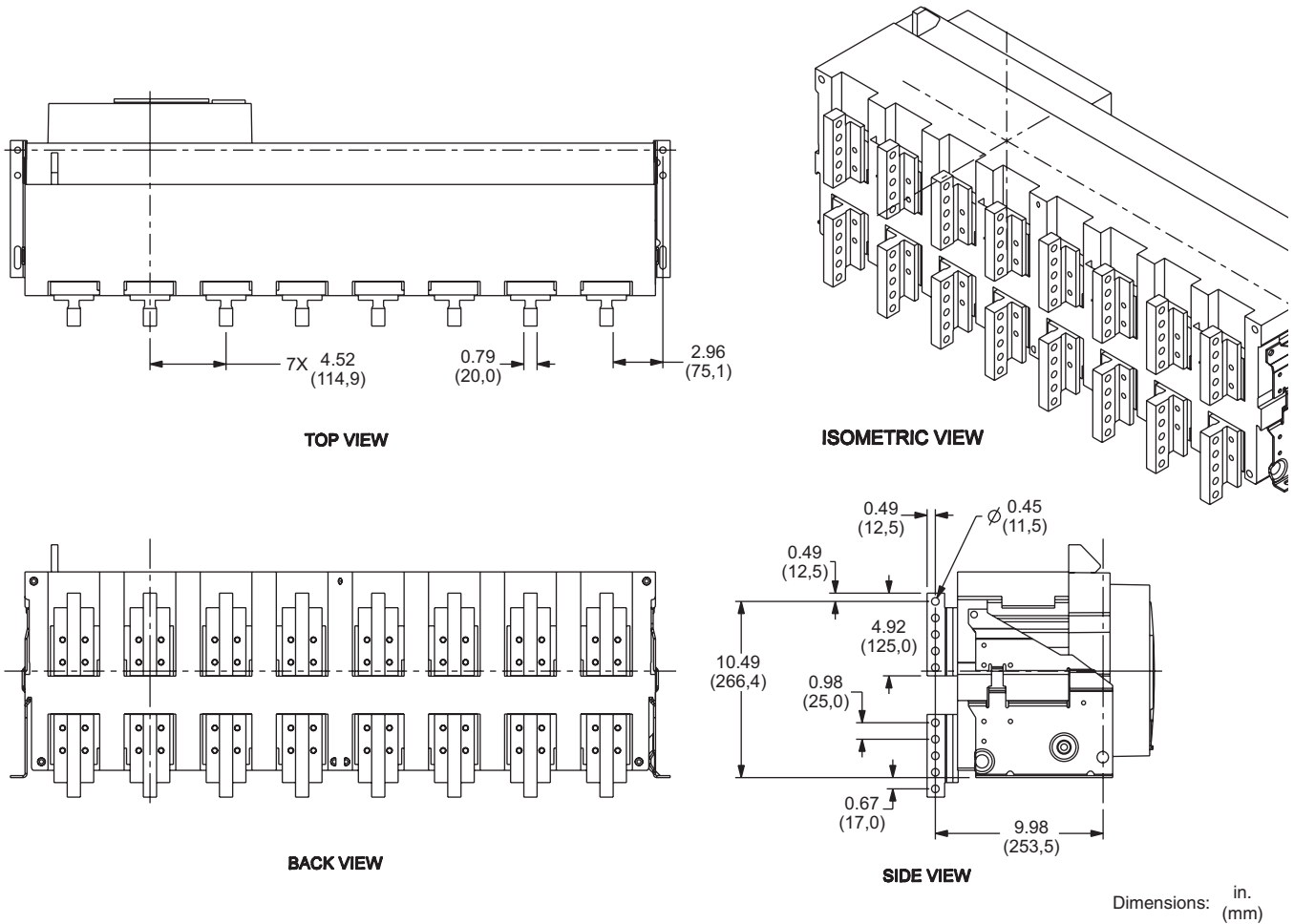



## Section 8—Accessory Dimensional Drawings

Accessory Dimensions.....	206
IFE Ethernet Interface .....	206
I/O (Input/Output) Application Module .....	206
IFM Modbus-SL Interface .....	206
FDM121 Switchboard Display Dimensions .....	207
FDM121 Switchboard Display Mounting Through Panel.....	207
FDM121 Switchboard Display Mounting On Panel .....	207
FDM128 Switchboard Display Dimensions .....	208
FDM128 Switchboard Display Mounting on Panel .....	208
Masterpact NT and NW Circuit Breaker Communication.....	209
Fixed Masterpact NT and NW Connection to the Communication Interface Module .....	210
Drawout Masterpact NT and NW Connection to the I/O and Communication Interface Module..	211

# Masterpact™ NT and NW Universal Power Circuit Breakers

## Accessory Dimensional Drawings

### Accessory Dimensions

Figure 169: IFE Ethernet Interface

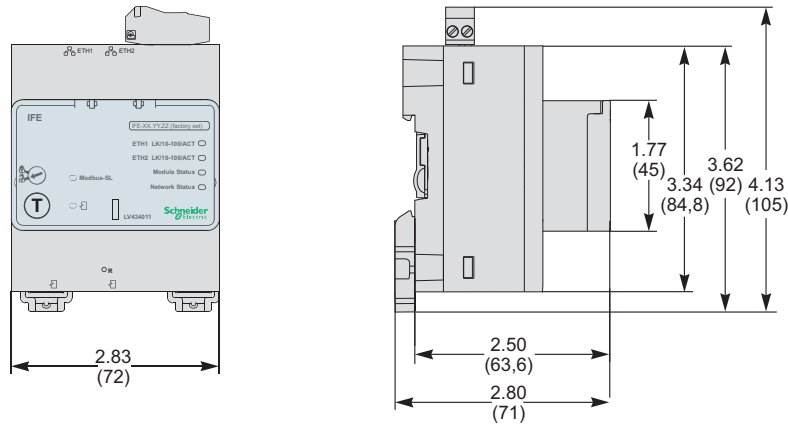

Dimensions: in.  
(mm)

Figure 170: I/O (Input/Output) Application Module

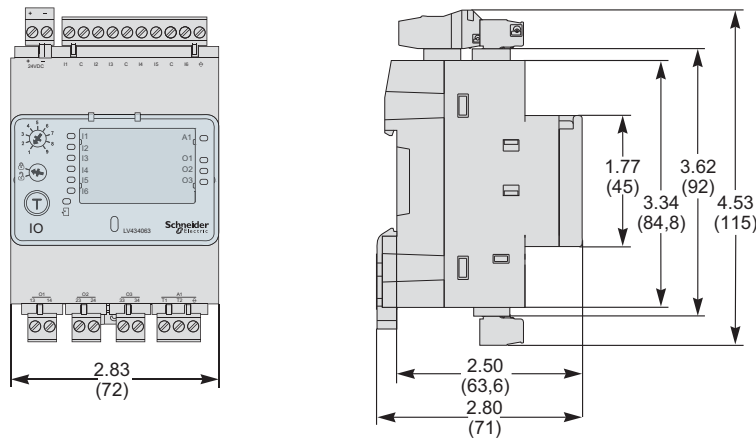

Dimensions: in.  
(mm)

Figure 171: IFM Modbus-SL Interface

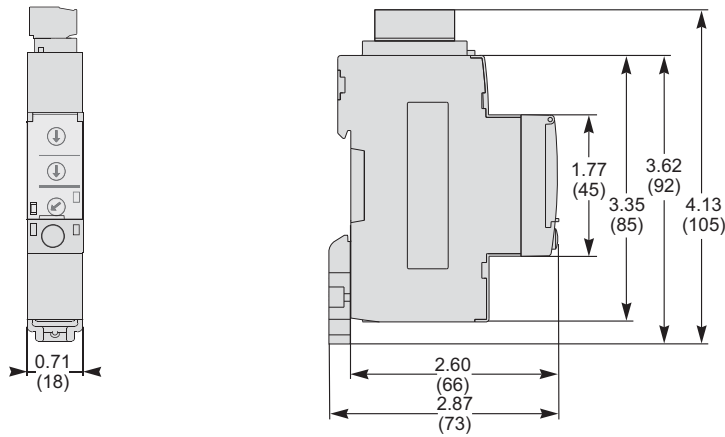

Dimensions: in.  
(mm)



# Masterpact™ NT and NW Universal Power Circuit Breakers Accessory Dimensional Drawings

Figure 175: FDM128 Switchboard Display Dimensions

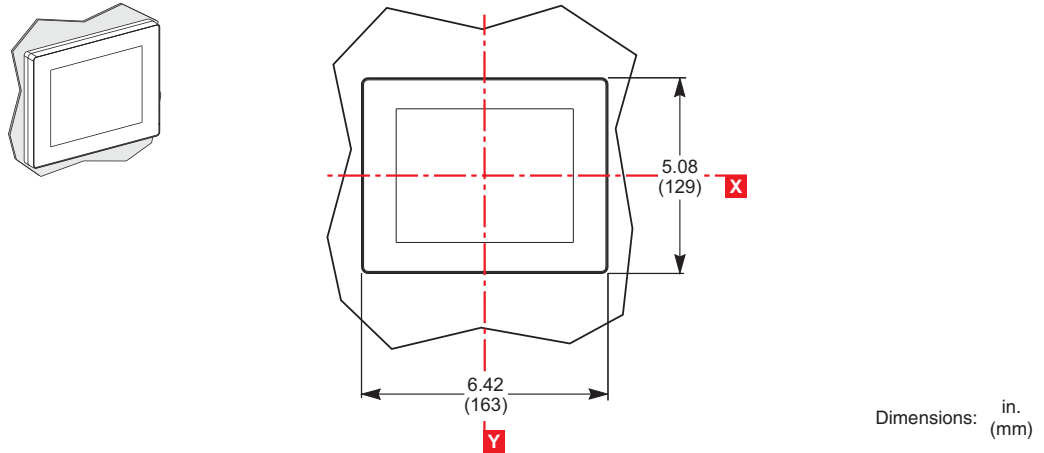
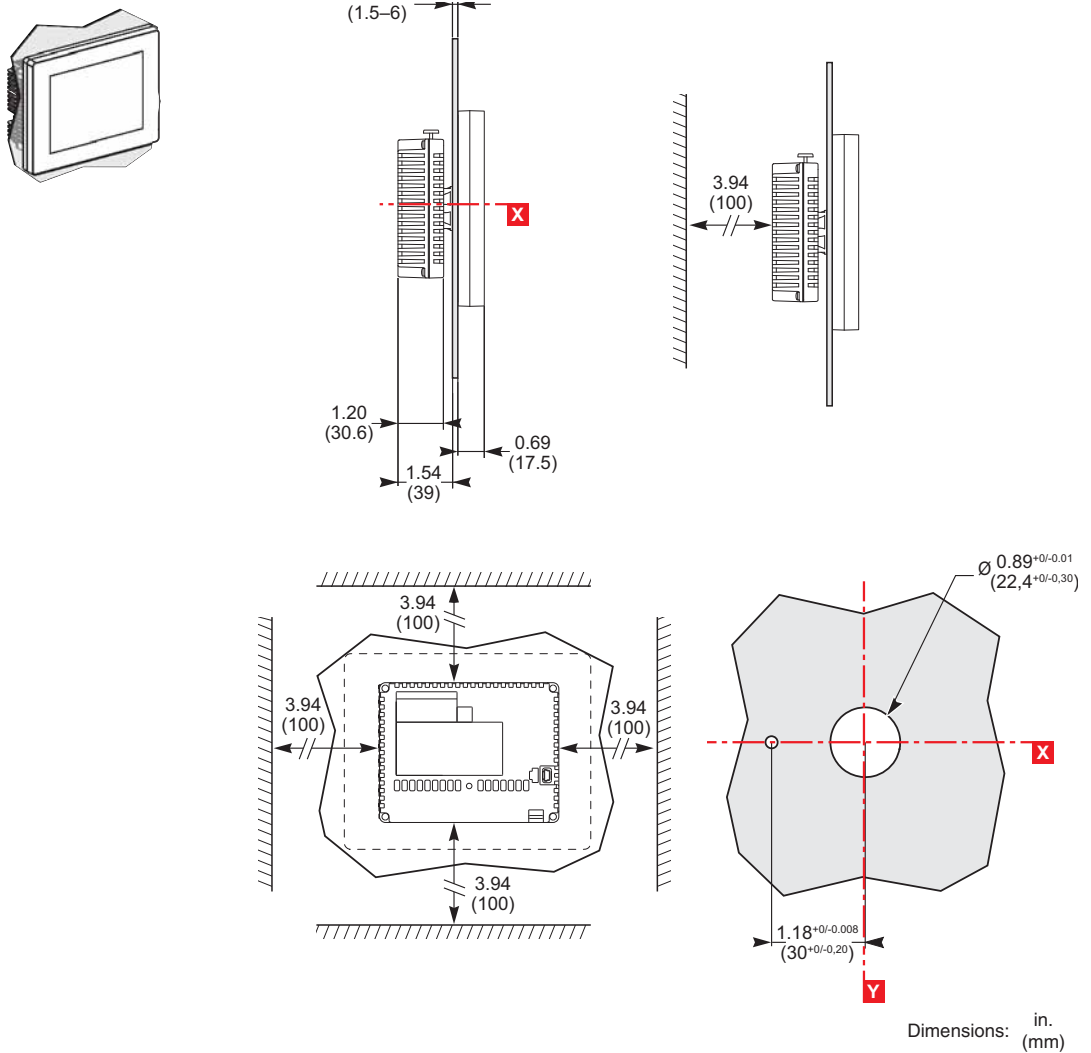
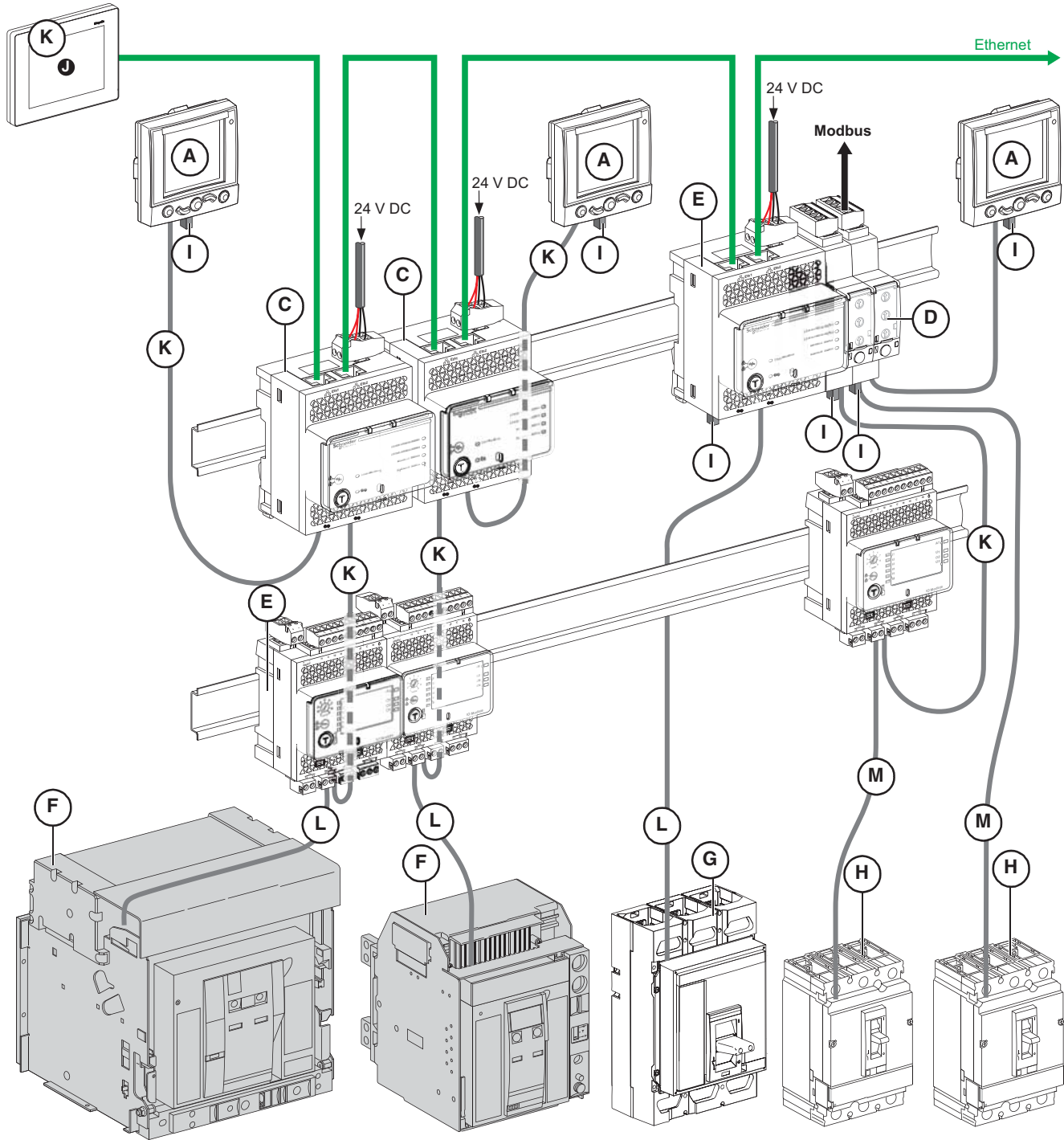

Figure 176: FDM128 Switchboard Display Mounting on Panel



# Masterpact™ NT and NW Universal Power Circuit Breakers Accessory Dimensional Drawings

**Figure 177: Masterpact NT and NW Circuit Breaker Communication**



- |                                 |                                     |                               |             |
|---------------------------------|-------------------------------------|-------------------------------|-------------|
| A. FDM121 (TRV00121)            | E. IO module (LV434063)             | I. ULP termination (TRV00880) | M. NSX cord |
| B. IFE module master (LV434011) | F. Masterpact NT/NW circuit breaker | J. FDM128 (LV434128)          |             |
| C. IFE module (LV434010)        | G. PowerPact P/R circuit breaker    | K. ULP cable                  |             |
| D. IFM module (TRV00210)        | H. PowerPact H/J/L circuit breaker  | L. Circuit breaker ULP cord   |             |

# Masterpact™ NT and NW Universal Power Circuit Breakers Accessory Dimensional Drawings

Figure 178: Fixed Masterpact NT and NW Connection to the Communication Interface Module

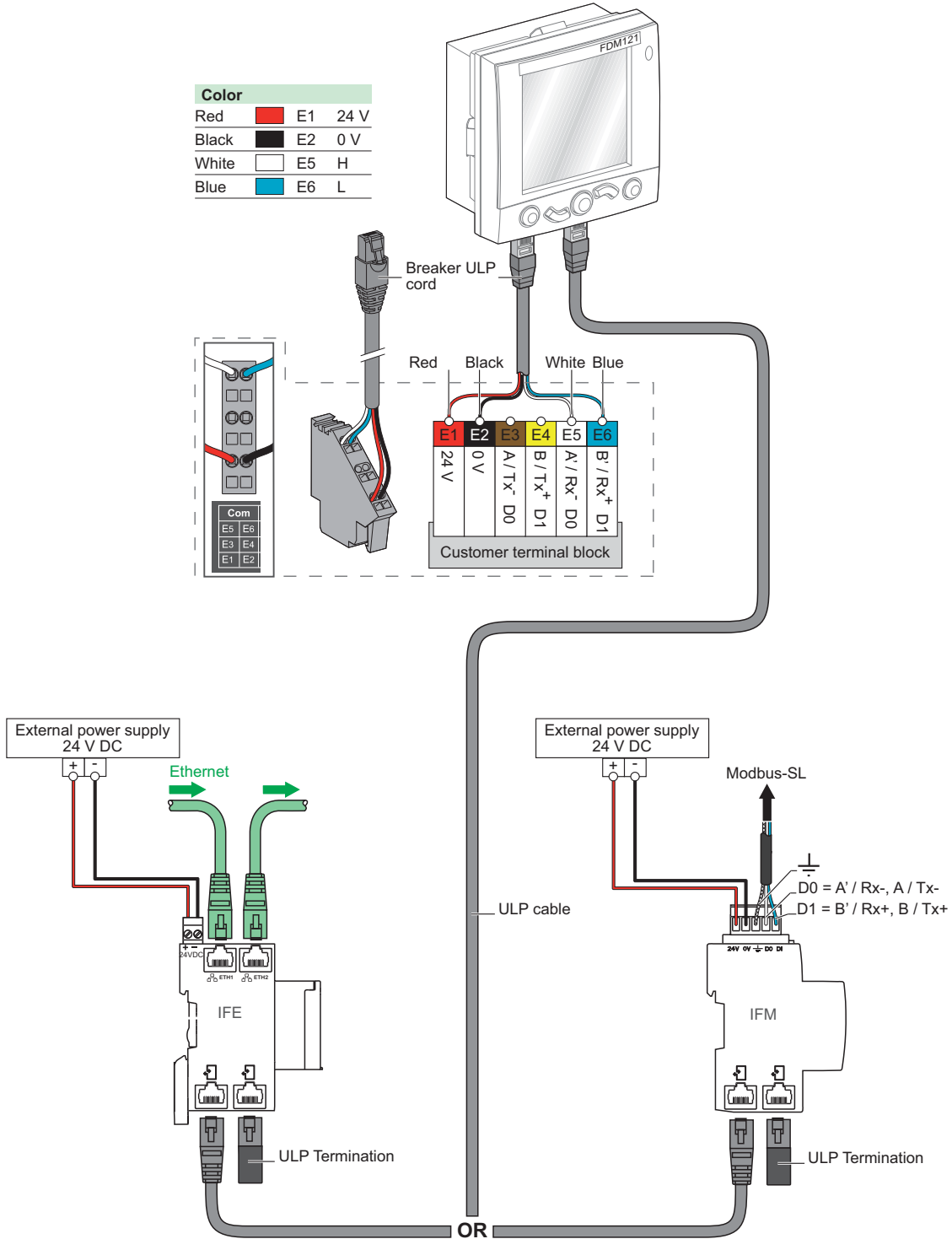

# Masterpact™ NT and NW Universal Power Circuit Breakers Accessory Dimensional Drawings

**Figure 179: Drawout Masterpact NT and NW Connection to the I/O and Communication Interface Module**

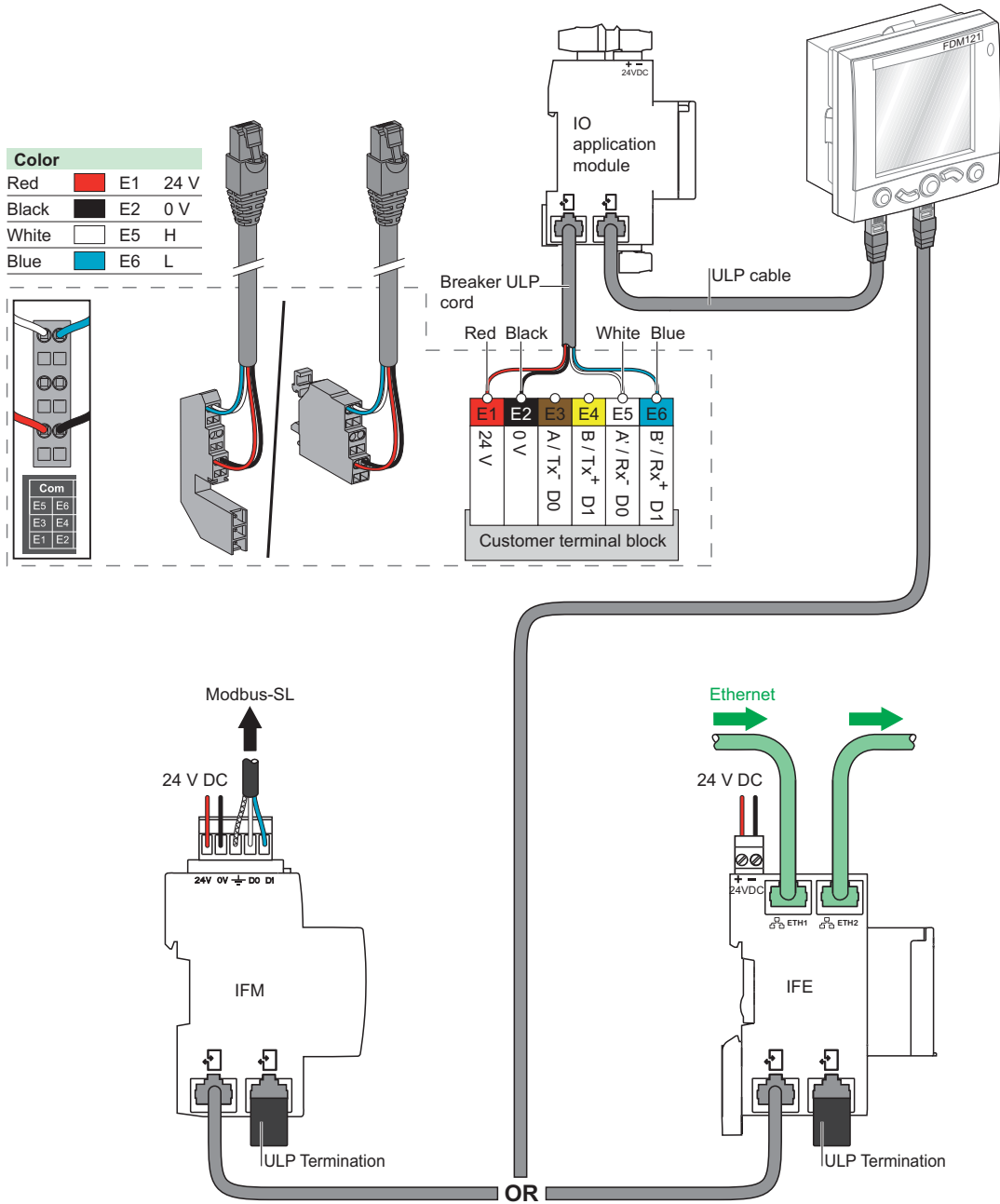

**Section 9—Selection**

Introduction .....213  
    Overview of Selection Procedure ..... 213  
Factory-Assembled Circuit Breakers and Switches ..... 215  
    T-Frame Circuit Breaker Selection ..... 215  
    T-Frame Switch Selection ..... 216  
    W-Frame Circuit Breaker Selection ..... 217  
    W-Frame Switch Selection ..... 220  
    Y-Frame Circuit Breaker Selection ..... 222  
    Y-Frame Switch Selection ..... 223



## Introduction

Masterpact circuit breakers are available in three frame sizes:

- T-frame circuit breakers: rated up to 800 A (ANSI Certified), up to 1600 A (UL® Listed), and up to 1600 A (IEC Rated).
- W-frame circuit breakers: rated up to 4000 A (ANSI Certified), up to 3000 A (UL Listed), and up to 4000 A (IEC Rated).
- Y-frame circuit breakers: rated up to 5000 A (ANSI Certified), up to 6000 A (UL Listed), and up to 6300 A (IEC Rated).

Within each range, several sensor plugs are available to determine the maximum trip rating of each circuit breaker. In addition to a sensor plug, an adjustable rating plug is available to get lower ampacity than that available with the sensor plug.

Masterpact circuit breakers can be equipped with a variety of Micrologic electronic trip unit configurations, ranging from basic circuit protection to more advanced relay protection and power metering capabilities. Additionally all electronic trip units within the new Micrologic family are field interchangeable and upgradeable. Each control unit is also equipped with an interchangeable and upgradeable adjustable rating plug which is used to select the long-time pickup setting of the circuit breaker.

**NOTE:** Masterpact circuit breakers are ordered by sensor plug rating, not ampere trip rating. The trip rating of the circuit breaker is determined by the setting of the adjustable rating plug. Sensor plugs and rating plugs are field replaceable.

## Overview of Selection Procedure

1. Select the completely assembled circuit breaker (circuit breaker frame plus trip unit):
  - The frame ampere rating required
  - The interrupting rating required
  - The sensor plug rating required
  - The connections
2. Select the trip unit, rating plug, and trip unit options.
3. Select circuit breaker frame options, if required.
4. Select cradle options, if required.

# Masterpact™ NT and NW Universal Power Circuit Breakers Selection

**Table 69: Circuit Breaker Selection Options**

Model Number	NT				NW				NW		
Frame type	T				W				Y (wide-construction)		
Maximum frame rating	ANSI	UL	UL	IEC	ANSI	ANSI	UL	IEC	ANSI	UL	IEC
	800 A	1200 A	1600 A	1600 A	3200 A	4000 A	3000 A	4000 A	6000 A	6000 A	6300 A
<b>Maximum Interrupting Rating (kA, 50/60 Hz)</b>											
AC rating	254 V	240 V	240 V	240 V	254 V	254 V	240 V	240 V	254 V	240 V	240 V
	42 kA	200 kA	200 kA	150 kA	200 kA	100 kA	200 kA	150 kA	200 kA	200 kA	150 kA
	508 V	480 V	480 V	440 V	508 V	508 V	480 V	440 V	508 V	480 V	440 V
	42 kA	100 kA	100 kA	130 kA	200 kA	100 kA	150 kA	150 kA	200 kA	150 kA	150 kA
	635 V	600 V	600 V	690 V	635 V	635 V	600 V	690 V	635 V	600 V	690 V
	N/A	50 kA	50 kA	42 kA	130 kA	85 kA	100 kA	100 kA	130 kA	100 kA	100 kA
<b>Construction</b>											
Drawout	X	X	—	X	X	—	X	X	X	X	X
Fixed (UL Listed and IEC Rated only)	X	X	X	X	X	X	X	X	X	X	X
<b>Termination</b>											
Rotatable rear terminals	X	X	X	X	X	X	X	X	X	X	X
Front-connected terminals	X	X	X	X	X	X	X	X	X	X	X
<b>Accessories Available for the Circuit Breaker and Cradle</b>											
<ul style="list-style-type: none"> <li>• Shunt close</li> <li>• Shunt trip</li> <li>• Undervoltage trip</li> <li>• Fixed time delay</li> <li>• Adjustable time delay</li> <li>• Spring-charging motor</li> <li>• Auxiliary contacts (standard)</li> </ul>				<ul style="list-style-type: none"> <li>• Ready-to-close contact</li> <li>• Overcurrent trip switch (standard)</li> <li>• Rack in interlock</li> <li>• Key locks for circuit breaker and cradle</li> <li>• Padlock attachment (circuit breaker plus cradle)</li> <li>• Mechanical interlocks</li> <li>• Cradle position switches</li> </ul>				<ul style="list-style-type: none"> <li>• Door interlock</li> <li>• Operations counter</li> <li>• Safety Shutter</li> <li>• Cradle rejection kit (standard)</li> <li>• Rail Padlocking</li> </ul>			
<b>Electronic Trip Unit Features</b>											
<ul style="list-style-type: none"> <li>• True RMS sensing</li> <li>• LSI</li> <li>• Ground-fault alarm (no trip)</li> <li>• Ground-fault trip</li> <li>• Ground-fault trip and programmable alarm</li> <li>• Adjustable rating plugs</li> <li>• Long-time pickup LED</li> </ul>				<ul style="list-style-type: none"> <li>• Trip indication LED</li> <li>• Zone-selective interlocking (ZSI)</li> <li>• Communications</li> <li>• LCD dot matrix display</li> <li>• Advanced user interface</li> <li>• Protective relay functions</li> <li>• Thermal imaging</li> </ul>				<ul style="list-style-type: none"> <li>• Neutral protection</li> <li>• Contact wear indication</li> <li>• Incremental fine-tuning of settings</li> <li>• Selectable long-time delay bands</li> <li>• Power measurement</li> <li>• Expanded memory</li> <li>• Enhanced power quality measurement</li> </ul>			

**Table 70: Micrologic Trip Unit Selection**

Design Platform Designation	Feature Type	Protection	Model Number
Basic Trip Unit	Basic	LS0 (IEC Rated)	2.0
		LI (UL Listed/ANSI Certified)	3.0
		LSI	5.0
Trip Unit with Ammeter	A	LS0 (IEC Rated)	2.0A
		LI (UL Listed/ANSI Certified)	3.0A
		LSI	5.0A
Trip Unit with Power Metering	P	LSIG	6.0A
		LSI	5.0P
		LSIG	6.0P
Trip Unit with Harmonic Metering	H	LSI	5.0H
		LSIG	6.0H

# Masterpact™ NT and NW Universal Power Circuit Breakers Selection

## Factory-Assembled Circuit Breakers and Switches

### T-Frame Circuit Breaker Selection

**Table 71: ANSI C37 Certified/UL 1066 Listed T-Frame Circuit Breakers**

Frame Rating	Model Number	Interrupting Rating			Sensor Plug Rating
		254 V	508 V	635 V	
800 A	NT08N1	42 kA	42 kA	—	100 A, 250 A, 400 A, 600 A, 800 A

**Table 72: UL 489 Listed T-Frame Circuit Breakers**

Frame Rating	Model Number	Interrupting Rating			Sensor Plug Rating
		240 V	480 V	600 V	
800 A	NT08N	50 kA	50 kA	35 kA	100 A, 250 A, 400 A, 600 A, 800 A
	NT08H	65 kA	50 kA	50 kA	100 A, 250 A, 400 A, 600 A, 800 A
	NT08L1 <sup>1</sup>	100 kA	65 kA	—	100 A, 250 A, 400 A, 600 A, 800 A
	NT08L <sup>1</sup>	200 kA	100 kA	—	100 A, 250 A, 400 A, 600 A, 800 A
	NT08LF <sup>1</sup>	200 kA	100 kA	—	100 A, 250 A, 400 A, 600 A, 800 A
1200 A	NT12N	50 kA	50 kA	35 kA	600 A, 800 A, 1000 A, 1200 A
	NT12H	65 kA	50 kA	50 kA	600 A, 800 A, 1000 A, 1200 A
	NT12L1 <sup>1</sup>	100 kA	65 kA	—	600 A, 800 A, 1000 A, 1200 A
	NT12L <sup>1</sup>	200 kA	100 kA	—	600 A, 800 A, 1000 A, 1200 A
	NT12LF <sup>1</sup>	200 kA	5100 kA	—	600 A, 800 A, 1000 A, 1200 A
1600 A <sup>2</sup>	NT16N	50 kA	50 kA	35 kA	800 A, 1000 A, 1200 A, 1600 A
	NT16H	65 kA	50 kA	50 kA	800 A, 1000 A, 1200 A, 1600 A
	NT16L1 <sup>1</sup>	100 kA	65 kA	—	800 A, 1000 A, 1200 A, 1600 A
	NT16L <sup>1</sup>	200 kA	100 kA	—	800 A, 1000 A, 1200 A, 1600 A
	NT16LF <sup>1</sup>	200 kA	5100 kA	—	800 A, 1000 A, 1200 A, 1600 A

<sup>1</sup> Not available in four-pole circuit breakers.

<sup>2</sup> Fixed-mount only. 1600A UL 489 drawout circuit breakers are not available.

**Table 73: IEC 60947-2 Rated T-Frame Circuit Breakers**

Frame Rating	Model Number	Interrupting Rating (kA)				Sensor Plug Rating (A)
		240 V	440 V	690 V	1000 V	
800 A	NT08H1	42 kA	42 kA	42 kA	—	250 A, 400 A, 630 A, 800 A
	NT08L1	150 kA	130 kA	25 kA	—	250 A, 400 A, 630 A, 800 A
1000 A	NT10H1	42 kA	42 kA	42 kA	—	400 A, 630 A, 800 A, 1000 A
	NT10L1	150 kA	130 kA	25 kA	—	400 A, 630 A, 800 A, 1000 A
1250 A	NT12H1	42 kA	42 kA	42 kA	—	630 A, 800 A, 1000 A, 1250 A
1600 A	NT16H1	42 kA	42 kA	42 kA	—	800 A, 1000 A, 1250 A, 1600 A

**NOTE:** L1F and LF circuit breakers are tested to show the arc flash hazard risk category as referenced by NFPA 70E.

# Masterpact™ NT and NW Universal Power Circuit Breakers Selection

## T-Frame Switch Selection

**Table 74: ANSI C37 Certified/UL 1066 Listed, Non-Automatic T-Frame Switch**

Frame Rating	Model Number	Interrupting Rating <sup>1</sup>			Short-Time (0.5 s) Rating
		254 V	508 V	635 V	
800 A	NT08NA	42 kA	42 kA	NA	42 kA
	NT08HA	42 kA	42 kA	22 kA	42 kA

<sup>1</sup> When used in conjunction with an overcurrent relay, circuit breaker, or fuse.

**Table 75: UL 489 Listed, Automatic T-Frame Switches**

Frame Rating	Model Number	Withstand Rating <sup>1</sup>			Instantaneous Override
		240 V	480 V	600 V	
800 A	NT08HF	65 kA	50 kA	50 kA	40 kA
	NT08HB <sup>2</sup>	200 kA	100 kA	N/A	10 kA
1200 A	NT12HF	65 kA	50 kA	50 kA	40 kA
	NT12HB <sup>2</sup>	200 kA	100 kA	N/A	10 kA
1600 A <sup>3</sup>	NT16HF	65 kA	50 kA	50 kA	40 kA
	NT16HB <sup>2</sup>	200 kA	100 kA	N/A	10 kA

<sup>1</sup> The withstand rating is the fault current (at rated voltage) that the switch will withstand without damage when protected by a circuit breaker with an equal continuous current rating.

<sup>2</sup> Not available in four-pole circuit breakers.

<sup>3</sup> Fixed-mount only. 1600A UL489 drawout switches are not available.

**Table 76: IEC 60947-3 Rated, Non-Automatic T-Frame Switches**

Frame Rating	Model Number	Interrupting Rating <sup>1</sup>				Short-Time (0.5 s) Rating
		240 V	440 V	690 V	1000 V	
800 A	NT08HA	42 kA	42 kA	42 kA	—	42 kA
1000 A	NT10HA	42 kA	42 kA	42 kA	—	42 kA
1250 A	NT12HA	42 kA	42 kA	42 kA	—	42 kA
1600 A	NT16HA	42 kA	42 kA	42 kA	—	42 kA

<sup>1</sup> When used in conjunction with an overcurrent relay, circuit breaker, or fuse.

# Masterpact™ NT and NW Universal Power Circuit Breakers Selection

## W-Frame Circuit Breaker Selection

**Table 77: ANSI C37/UL 1066 Listed W-Frame Circuit Breakers**

Frame Rating	Model Number	Interrupting Rating			Sensor Plug Rating
		254 V	508 V	635 V	
800 A	NW08N1	42 kA	42 kA	42 kA	100 A, 250 A, 400 A, 600 A, 800 A
	NW08H1	65 kA	65 kA	65 kA	100 A, 250 A, 400 A, 600 A, 800 A
	NW08H2	85 kA	85 kA	85 kA	100 A, 250 A, 400 A, 600 A, 800 A
	NW08H3	100 kA	100 kA	85 kA	100 A, 250 A, 400 A, 600 A, 800 A
	NW08L1 <sup>1</sup>	200 kA	200 kA	130 kA	100 A, 250 A, 400 A, 600 A, 800 A
	NW08L1F <sup>1</sup>	200 kA	200 kA	130 kA	100 A, 250 A, 400 A, 600 A, 800 A
1600 A	NW16N1	42 kA	42 kA	42 kA	800 A, 1000 A, 1200 A, 1600 A
	NW16H1	65 kA	65 kA	65 kA	800 A, 1000 A, 1200 A, 1600 A
	NW16H2	85 kA	85 kA	85 kA	800 A, 1000 A, 1200 A, 1600 A
	NW16H3	100 kA	100 kA	85 kA	800 A, 1000 A, 1200 A, 1600 A
	NW16L1 <sup>1</sup>	200 kA	200 kA	130 kA	800 A, 1000 A, 1200 A, 1600 A
	NW16L1F <sup>1</sup>	200 kA	200 kA	130 kA	800 A, 1000 A, 1200 A, 1600 A
2000 A	NW20H1	65 kA	65 kA	65 kA	1000 A, 1200 A, 1600 A, 2000 A
	NW20H2	85 kA	85 kA	85 kA	1000 A, 1200 A, 1600 A, 2000 A
	NW20H3	100 kA	100 kA	85 kA	1000 A, 1200 A, 1600 A, 2000 A
	NW20L1 <sup>1</sup>	100 kA	200 kA	130 kA	1000 A, 1200 A, 1600 A, 2000 A
	NW20L1F <sup>1</sup>	200 kA	200 kA	130 kA	1000 A, 1200 A, 1600 A, 2000 A
3200 A	NW32H1	65 kA	65 kA	65 kA	1600 A, 2000 A, 2500 A, 3000 A, 3200 A
	NW32H2	85 kA	85 kA	85 kA	1600 A, 2000 A, 2500 A, 3000 A, 3200 A
	NW32H3	100 kA	100 kA	85 kA	1600 A, 2000 A, 2500 A, 3000 A, 3200 A
4000 A (W-Frame)	NW40BH1	65 kA	65 kA	65 kA	2000 A, 2500 A, 3000 A, 3200 A, 3600 A, 4000 A
	NW40BH2	85 kA	85 kA	85 kA	2000 A, 2500 A, 3000 A, 3200 A, 3600 A, 4000 A
	NW40BH3	100 kA	100 kA	85 kA	2000 A, 2500 A, 3000 A, 3200 A, 3600 A, 4000 A

<sup>1</sup> Not available for fixed-mounted or four-pole circuit breakers.

**NOTE:** L1F circuit breakers are tested to show the arc flash hazard risk category as referenced by NFPA 70E.

# Masterpact™ NT and NW Universal Power Circuit Breakers Selection

**Table 78: UL 489 Listed W-Frame Circuit Breakers**

Frame Rating	Model Number	Interrupting Rating			Sensor Plug Rating
		240 V	480 V	600 V	
800 A	NW08N	65 kA	65 kA	50 kA	100 A, 250 A, 400 A, 600 A, 800 A
	NW08H	100 kA	100 kA	85 kA	100 A, 250 A, 400 A, 600 A, 800 A
	NW08L <sup>1</sup>	200 kA	150 kA	100 kA	100 A, 250 A, 400 A, 600 A, 800 A
	NW08LF <sup>1</sup>	200 kA	150 kA	100 kA	100 A, 250 A, 400 A, 600 A, 800 A
1200 A	NW12N	65 kA	65 kA	50 kA	600 A, 800 A, 1000 A, 1200 A
	NW12H	100 kA	100 kA	85 kA	600 A, 800 A, 1000 A, 1200 A
	NW12L <sup>1</sup>	200 kA	150 kA	100 kA	600 A, 800 A, 1000 A, 1200 A
	NW12LF <sup>1</sup>	200 kA	150 kA	100 kA	600 A, 800 A, 1000 A, 1200 A
1600 A	NW16N	65 kA	65 kA	50 kA	800 A, 1000 A, 1200 A, 1600 A
	NW16H	100 kA	100 kA	85 kA	800 A, 1000 A, 1200 A, 1600 A
	NW16L <sup>1</sup>	200 kA	150 kA	100 kA	800 A, 1000 A, 1200 A, 1600 A
	NW16LF <sup>1</sup>	200 kA	150 kA	100 kA	800 A, 1000 A, 1200 A, 1600 A
2000 A	NW20N	65 kA	65 kA	50 kA	1000 A, 1200 A, 1600 A, 2000 A
	NW20H	100 kA	100 kA	85 kA	1000 A, 1200 A, 1600 A, 2000 A
	NW20L <sup>1</sup>	200 kA	150 kA	100 kA	1000 A, 1200 A, 1600 A, 2000 A
	NW20LF <sup>1</sup>	200 kA	150 kA	100 kA	1000 A, 1200 A, 1600 A, 2000 A
2500 A	NW25H	100 kA	100 kA	85 kA	1200 A, 1600 A, 2000 A, 2500 A
	NW25L <sup>1</sup>	200 kA	150 kA	100 kA	1200 A, 1600 A, 2000 A, 2500 A
3000 A	NW30H	100 kA	100 kA	85 kA	1600 A, 2000 A, 2500 A, 3000 A
	NW30L <sup>1</sup>	200 kA	150 kA	100 kA	1600 A, 2000 A, 2500 A, 3000 A

<sup>1</sup> Not available for fixed-mounted or four-pole drawout circuit breakers.

**NOTE:** LF circuit breakers are tested to show the arc flash hazard risk category as referenced by NFPA 70E.

# Masterpact™ NT and NW Universal Power Circuit Breakers Selection

**Table 79: IEC 60947-2 Rated W-Frame Circuit Breakers**

Frame Rating	Model Number	Interrupting Rating				Sensor Plug Rating
		240 V	440 V	690 V	1150 V	
800 A	NW08N1	42 kA	42 kA	42 kA	—	400 A, 630 A, 800 A
	NW08H1	65 kA	65 kA	65 kA	—	400 A, 630 A, 800 A
	NW08H2	100 kA	100 kA	85 kA	—	400 A, 630 A, 800 A
	NW08L1 <sup>1</sup>	150 kA	150 kA	100 kA	—	400 A, 630 A, 800 A
	NW08H10 <sup>1</sup>	—	—	—	50 kA	400 A, 630 A, 800 A
1000 A	NW10N1	42 kA	42 kA	42 kA	—	400 A, 630 A, 800 A, 1000 A
	NW10H1	65 kA	65 kA	65 kA	—	400 A, 630 A, 800 A, 1000 A
	NW10H2	100 kA	100 kA	85 kA	—	400 A, 630 A, 800 A, 1000 A
	NW10L1 <sup>1</sup>	150 kA	150 kA	100 kA	—	400 A, 630 A, 800 A, 1000 A
	NW10H10 <sup>1</sup>	—	—	—	50 kA	400 A, 630 A, 800 A, 1000 A
1250 A	NW12N1	42 kA	42 kA	42 kA	—	630 A, 800 A, 1000, A1250 A
	NW12H1	65 kA	65 kA	65 kA	—	630 A, 800 A, 1000 A, 1250 A
	NW12H2	100 kA	100 kA	85 kA	—	630 A, 800 A, 1000 A, 1250 A
	NW12L1 <sup>1</sup>	150 kA	150 kA	100 kA	—	630 A, 800 A, 1000 A, 1250 A
	NW12H10 <sup>1</sup>	—	—	—	50 kA	630 A, 800 A, 1000 A, 1250 A
1600 A	NW16N1	42 kA	42 kA	42 kA	—	800 A, 1000 A, 1250 A, 1600 A
	NW16H1	65 kA	65 kA	65 kA	—	800 A, 1000 A, 1250 A, 1600 A
	NW16H2	100 kA	100 kA	85 kA	—	800 A, 1000 A, 1250 A, 1600 A
	NW16L1 <sup>1</sup>	150 kA	150 kA	100 kA	—	800 A, 1000 A, 1250 A, 1600 A
	NW16H10 <sup>1</sup>	—	—	—	50 kA	800 A, 1000 A, 1250 A, 1600 A
2000 A	NW20H1	65 kA	65 kA	65 kA	—	1000 A, 1250 A, 1600 A, 2000 A
	NW20H2	100 kA	100 kA	85 kA	—	1000 A, 1250 A, 1600 A, 2000 A
	NW20H3 <sup>1</sup>	150 kA	150 kA	100 kA	—	1000 A, 1250 A, 1600 A, 2000 A
	NW20L1 <sup>1</sup>	150 kA	150 kA	100 kA	—	1000 A, 1250 A, 1600 A, 2000 A
	NW20H10 <sup>1</sup>	—	—	—	50 kA	1000 A, 1250 A, 1600 A, 2000 A
2500 A	NW25H1	65 kA	65 kA	65	—	1250 A, 1600 A, 2000 A, 2500 A
	NW25H2	100 kA	100 kA	85	—	1250 A, 1600 A, 2000 A, 2500 A
	NW25H3 <sup>1</sup>	150 kA	150 kA	100	—	1250 A, 1600 A, 2000 A, 2500 A
	NW25H10 <sup>1</sup>	—	—	—	50 kA	1250 A, 1600 A, 2000 A, 2500 A
3200 A	NW32H1	65 kA	65 kA	65 kA	—	1600 A, 2000 A, 2500 A, 3200 A
	NW32H2	100 kA	100 kA	85 kA	—	1600 A, 2000 A, 2500 A, 3200 A
	NW32H3 <sup>1</sup>	150 kA	150 kA	100 kA	—	1600 A, 2000 A, 2500 A, 3200 A
	NW32H10 <sup>1</sup>	—	—	—	50 kA	1600 A, 2000 A, 2500 A, 3200 A
4000 A	NW40H1	65 kA	65 kA	65 kA	—	2000 A, 2500 A, 3200 A, 4000 A
	NW40H2	100 kA	100 kA	85 kA	—	2000 A, 2500 A, 3200 A, 4000 A
	NW40H3 <sup>1</sup>	150 kA	150 kA	100 kA	—	2000 A, 2500 A, 3200 A, 4000 A
	NW40H10 <sup>1</sup>	—	—	—	50 kA	2000 A, 2500 A, 3200 A, 4000 A

<sup>1</sup> Not available for fixed-mounted circuit breakers.

# Masterpact™ NT and NW Universal Power Circuit Breakers Selection

## W-Frame Switch Selection

**Table 80: ANSI C37 Certified/UL 1066 Listed, Non-Automatic Switch**

Frame Rating	Model Number	Interrupting Rating <sup>1</sup>			Short-Time (0.5 s) Rating
		254 V	508 V	635 V	
800 A	NW08HA	65 kA	65 kA	65 kA	65 kA
1600 A	NW16HA	65 kA	65 kA	65 kA	65 kA
2000 A	NW20HA	65 kA	65 kA	65 kA	65 kA
3200 A	NW32HA	65 kA	65 kA	65 kA	65 kA

<sup>1</sup> When used in conjunction with an overcurrent relay, circuit breaker, or fuse.

**Table 81: ANSI C37 Certified/UL 1066 Listed, Drawout Automatic Switch**

Frame Rating (W-Frame)	Model Number	Interrupting Rating <sup>1</sup>			Short-Time (0.5 s) Rating
		254 V	508 V	635 V	
800 A	NW08HF	100 kA	100 kA	85 kA	85 kA
	NW08HC <sup>2</sup>	200 kA	200 kA	130 kA	30 kA
1600 A	NW16HF	100 kA	100 kA	85 kA	85 kA
	NW16HC <sup>2</sup>	200 kA	200 kA	130 kA	30 kA
2000 A	NW20HF	100 kA	100 kA	85 kA	85 kA
	NW20HC <sup>2</sup>	200 kA	200 kA	130 kA	30 kA
3200 A	NW32HF	100 kA	100 kA	85 kA	85 kA

<sup>1</sup> When used in conjunction with an overcurrent relay, circuit breaker, or fuse.

<sup>2</sup> Not available in 4P.

**Table 82: ANSI C37 Certified/UL 1066 Listed, Fixed Automatic Switch**

Frame Rating (W-Frame)	Model Number	Interrupting Rating <sup>1</sup>			Short-Time (0.5 s) Rating
		254 V	508 V	635 V	
800 A	NW08HF	100 kA	100 kA	85 kA	85 kA
1600 A	NW16HF	100 kA	100 kA	85 kA	85 kA
2000 A	NW20HF	100 kA	100 kA	85 kA	85 kA
3200 A	NW32HF	100 kA	100 kA	85 kA	85 kA

<sup>1</sup> When used in conjunction with an overcurrent relay, circuit breaker, or fuse.

**Table 83: UL 489 Listed, Fixed Automatic Switch**

Frame Rating	Model Number	Withstand Rating <sup>1</sup>			Instantaneous Override
		240 V	480 V	600 V	
800 A	NW08HF	100 kA	100 kA	85 kA	40 kA
1200 A	NW12HF	100 kA	100 kA	85 kA	40 kA
1600 A	NW16HF	100 kA	100 kA	85 kA	40 kA
2000 A	NW20HF	100 kA	100 kA	85 kA	40 kA
2500 A	NW25HF	100 kA	100 kA	85 kA	65 kA
3000 A	NW30HF	100 kA	100 kA	85 kA	65 kA

<sup>1</sup> The withstand rating is the fault current (at rated voltage) that the switch will withstand without damage when protected by a circuit breaker with an equal continuous current rating.



# Masterpact™ NT and NW Universal Power Circuit Breakers Selection

**Table 84: UL 489 Listed, Drawout Automatic Switch**

Frame Rating	Model Number	Withstand Rating <sup>1</sup>			Instantaneous Override
		240 V	480 V	600 V	
800 A	NW08HF	100 kA	100 kA	85 kA	40 kA
	NW08HB <sup>2</sup>	200 kA	150 kA	100 kA	35 kA
1200 A	NW12HF	100 kA	100 kA	85 kA	40 kA
	NW12HB <sup>2</sup>	200 kA	150 kA	100 kA	35 kA
1600 A	NW16HF	100 kA	100 kA	85 kA	40 kA
	NW16HB <sup>2</sup>	200 kA	150 kA	100 kA	35 kA
2000 A	NW20HF	100 kA	100 kA	85 kA	40 kA
	NW20HB <sup>2</sup>	200 kA	150 kA	100 kA	35 kA
2500 A	NW25HF	100 kA	100 kA	85 kA	65 kA
	NW25HB <sup>2</sup>	200 kA	150 kA	100 kA	65 kA
3000 A	NW30HF	100 kA	100 kA	85 kA	65 kA
	NW30HB <sup>2</sup>	200 kA	150 kA	100 kA	65 kA

<sup>1</sup> The withstand rating is the fault current (at rated voltage) that the switch will withstand without damage when protected by a circuit breaker with an equal continuous current rating.

<sup>2</sup> Not available in 4P.

**Table 85: IEC 60947-3 Rated, Automatic Switch**

Frame Rating	Model Number	Withstand Rating <sup>1</sup>			Instantaneous Override
		240 V	440 V	690 V	
800 A	NW08HF	85 kA	85 kA	85 kA	85 kA
1000 A	NW10HF	85 kA	85 kA	85 kA	85 kA
1250 A	NW12HF	85 kA	85 kA	85 kA	85 kA
1600 A	NW16HF	85 kA	85 kA	85 kA	85 kA
2000 A	NW20HF	85 kA	85 kA	85 kA	85 kA
2500 A	NW25HF	85 kA	85 kA	85 kA	85 kA
3200 A	NW32HF	85 kA	85 kA	85 kA	85 kA
4000 A	NW40HF	85 kA	85 kA	85 kA	85 kA

<sup>1</sup> The withstand rating is the fault current (at rated voltage) that the switch will withstand without damage when protected by a circuit breaker with an equal continuous current rating.

# Masterpact™ NT and NW Universal Power Circuit Breakers Selection

**Table 86: IEC 60947-3 Rated, Non-Automatic Switch**

Frame Rating	Model Number	Interrupting Rating <sup>1</sup>				Short-Time (0.5 s) Rating
		240 V	440 V	690 V	1150 V	
800 A	NW08NA	42 kA	42 kA	42 kA	—	42 kA
	NW08HA	50 kA	50 kA	50 kA	—	50 kA
	NW08HA10 <sup>2</sup>	—	—	—	50 kA	50 kA
1000 A	NW10NA	42 kA	42 kA	42 kA	—	42 kA
	NW10HA	50 kA	50 kA	50 kA	—	50 kA
	NW10HA10 <sup>2</sup>	—	—	—	50 kA	50 kA
1250 A	NW12NA	42 kA	42 kA	42 kA	—	42 kA
	NW12HA	50 kA	50 kA	50 kA	—	50 kA
	NW12HA10 <sup>2</sup>	—	—	—	50 kA	50 kA
1600 A	NW16NA	42 kA	42 kA	42 kA	—	42 kA
	NW16HA	50 kA	50 kA	50 kA	—	50 kA
	NW16HA10 <sup>2</sup>	—	—	—	50 kA	50 kA
2000 A	NW20HA	50 kA	50 kA	50 kA	—	50 kA
	NW20HA10 <sup>2</sup>	—	—	—	50 kA	50 kA
2500 A	NW25HA	50 kA	50 kA	50 kA	—	50 kA
	NW25HA10 <sup>2</sup>	—	—	—	50 kA	50 kA
3200 A	NW32HA	50 kA	50 kA	50 kA	—	50 kA
	NW32HA10 <sup>2</sup>	—	—	—	50 kA	50 kA
4000 A	NW40HA	50 kA	50 kA	50 kA	—	50 kA
	NW40HA10 <sup>2</sup>	—	—	—	50 kA	50 kA

<sup>1</sup> When used in conjunction with an overcurrent relay, circuit breaker, or fuse.

<sup>2</sup> Not available for fixed-mounted circuit breakers.

## Y-Frame Circuit Breaker Selection

**Table 87: ANSI C37 Certified/UL 1066 Listed Y-Frame Circuit Breakers**

Frame Rating	Model Number	Interrupting Rating (kA)			Sensor Plug Rating (A)
		254 V	508 V	635 V	
3200 A to 4000 A	NW32L1 <sup>1</sup>	200 kA	200 kA	130 kA	2000 A, 2500 A, 3000 A, 3200 A
	NW40H2	85 kA	85 kA	85 kA	2000 A, 2500 A, 3000 A, 3200 A, 4000 A
	NW40H3	100 kA	100 kA	85 kA	2000 A, 2500 A, 3000 A, 3200 A, 4000 A
	NW40L1 <sup>1</sup>	200 kA	200 kA	130 kA	2000 A, 2500 A, 3000 A, 3200 A, 4000 A
5000 A	NW50H2	85 kA	85 kA	85 kA	2500 A, 3000 A, 3200 A, 4000 A, 5000 A
	NW50H3	100 kA	100 kA	85 kA	2500 A, 3000 A, 3200 A, 4000 A, 5000 A
	NW50L1 <sup>1</sup>	200 kA	200 kA	130 kA	2500 A, 3000 A, 3200 A, 4000 A, 5000 A

<sup>1</sup> Not available for fixed-mounted or four-pole drawout circuit breakers.

**Table 88: UL 489 Listed Y-Frame Circuit Breakers**

Frame Rating	Model Number	Interrupting Rating			Sensor Plug Rating
		240 V	480 V	600 V	
4000 A	NW40H	100 kA	100 kA	85 kA	2000 A, 2500 A, 3000 A, 4000 A
	NW40L <sup>1</sup>	200 kA	150 kA	100 kA	2000 A, 2500 A, 3000 A, 4000 A
5000 A	NW50H	100 kA	100 kA	85 kA	2500 A, 3000 A, 4000 A, 5000 A
	NW50L <sup>1</sup>	200 kA	150 kA	100 kA	2500 A, 3000 A, 4000 A, 5000 A
6000 A	NW60H	100 kA	100 kA	85 kA	3000 A, 4000 A, 5000 A, 6000 A
	NW60L <sup>1</sup>	200 kA	150 kA	100 kA	3000 A, 4000 A, 5000 A, 6000 A

<sup>1</sup> Not available for fixed-mounted or four-pole drawout circuit breakers.

# Masterpact™ NT and NW Universal Power Circuit Breakers Selection

**Table 89: IEC 60947-2 Rated Y-Frame Circuit Breakers**

Frame Rating	Model Number	Interrupting Rating			Sensor Plug Rating
		240 V	440 V	690 V	
4000 A	NW40BH1	100 kA	100 kA	100 kA	2000 A, 2500 A, 3200 A, 4000 A
	NW40BH2	150 kA	150 kA	100 kA	2000 A, 2500 A, 3200 A, 4000 A
5000 A	NW50H1	100 kA	100 kA	100 kA	2500 A, 3200 A, 4000 A, 5000 A
	NW50H2	150 kA	150 kA	100 kA	2500 A, 3200 A, 4000 A, 5000 A
6300 A	NW63H1	100 kA	100 kA	100 kA	3200 A, 4000 A, 5000 A, 6300 A
	NW63H2	150 kA	150 kA	100 kA	3200 A, 4000 A, 5000 A, 6300 A

## Y-Frame Switch Selection

**Table 90: ANSI C37 Certified/UL 1066 Listed, Non-Automatic Switches**

Frame Rating	Model Number	Interrupting Rating (kA) <sup>1</sup>			Short-Time (0.5 s) Rating
		254 V	508 V	635 V	
4000 A	NW40HA	85 kA	85 kA	85 kA	85 kA
5000 A	NW50HA	85 kA	85 kA	85 kA	85 kA

<sup>1</sup> When used in conjunction with an overcurrent relay, circuit breaker, or fuse.

**Table 91: ANSI C37 Certified/UL 1066 Listed, Drawout Automatic Switches**

Frame Rating (Y-Frame)	Model Number	Interrupting Rating <sup>1</sup>			Short-Time (0.5 s) Rating
		254 V	508 V	635 V	
3200 A	NW32HC <sup>2</sup>	200 kA	200 kA	130 kA	100 kA
4000 A	NW40HF	100 kA	100 kA	85 kA	85 kA
	NW40HC <sup>2</sup>	200 kA	200 kA	130 kA	100 kA
5000 A	NW50HF	100 kA	100 kA	85 kA	85 kA
	NW50HC <sup>2</sup>	200 kA	200 kA	130 kA	100 kA

<sup>1</sup> When used in conjunction with an overcurrent relay, circuit breaker, or fuse.

<sup>2</sup> Not available in 4P.

**Table 92: ANSI C37 Certified/UL 1066 Listed, Fixed Automatic Switches**

Frame Rating (Y-Frame)	Model Number	Interrupting Rating <sup>1</sup>			Short-Time (0.5 s) Rating
		254 V	508 V	635 V	
4000 A	NW40HF	100 kA	100 kA	85 kA	85 kA
5000 A	NW50HF	100 kA	100 kA	85 kA	85 kA

<sup>1</sup> When used in conjunction with an overcurrent relay, circuit breaker, or fuse.

**Table 93: UL 489 Listed, Fixed Automatic Switches**

Frame Rating	Model Number	Withstand Rating <sup>1</sup>			Instantaneous Override
		240 V	480 V	600 V	
4000 A	NW40HF	100 kA	100 kA	85 kA	75 kA
5000 A	NW50HF	100 kA	100 kA	85 kA	75 kA
6000 A	NW60HF	100 kA	100 kA	85 kA	75 kA

<sup>1</sup> The withstand rating is the fault current (at rated voltage) that the switch will withstand without damage when protected by a circuit breaker with an equal continuous current rating.

# Masterpact™ NT and NW Universal Power Circuit Breakers Selection

**Table 94: UL 489 Listed, Drawout Automatic Switches**

Frame Rating	Model Number	Withstand Rating <sup>1</sup>			Instantaneous Override
		240 V	480 V	600 V	
4000 A	NW40HF	100 kA	100 kA	85 kA	75 kA
	NW40HB <sup>2</sup>	1200 kA	150 kA	100 kA	75 kA
5000 A	NW50HF	100 kA	100 kA	85 kA	75 kA
	NW50HB <sup>2</sup>	200 kA	150 kA	100 kA	75 kA
6000 A	NW60HF	100 kA	100 kA	85 kA	75 kA
	NW60HB <sup>2</sup>	200 kA	150 kA	100 kA	75 kA

<sup>1</sup> The withstand rating is the fault current (at rated voltage) that the switch will withstand without damage when protected by a circuit breaker with an equal continuous current rating.

<sup>2</sup> Not available in 4P.

**Table 95: IEC 60947-3 Rated, Non-Automatic Switches**

Frame Rating	Model Number	Interrupting Rating <sup>1</sup>			Short-Time (0.5 s) Rating
		240 V	440 V	690 V	
4000 A	NW40BHA	85 kA	85 kA	85 kA	85 kA
5000 A	NW50HA	85 kA	85 kA	85 kA	85 kA
6300 A	NW63HA	85 kA	85 kA	85 kA	85 kA

<sup>1</sup> When used in conjunction with an overcurrent relay, circuit breaker, or fuse.

## **Section 10—Trip Curves**

Micrologic 6.0 A/P/H Trip Units: .....	226
Ground Fault I <sup>2</sup> t OFF and ON, I <sub>n</sub> ≤ 400 A .....	226
Ground Fault I <sup>2</sup> t OFF and ON, 400 A < I <sub>n</sub> ≤ 1200 A .....	227
Ground Fault I <sup>2</sup> t OFF and ON, I <sub>n</sub> > 1200 A .....	228
Micrologic 5.0/6.0 A/P/H Trip Units .....	229
Long-Time Pickup and Delay, Short-Time Pickup, and I <sup>2</sup> t OFF Delay .....	229
Short-Time Pickup and I <sup>2</sup> t ON Delay .....	230
Instantaneous Pickup, 2x to 15x and OFF .....	231
Micrologic 3.0A Trip Units .....	232
Long-Time Pickup and Delay .....	232
Instantaneous Pickup, 1.5X to 12X .....	233
Micrologic 2.0A Trip Unit .....	234
Micrologic 2.0/3.0/5.0/6.0 A/P/H Trip Unit Instantaneous Override Values.....	235
Masterpact NW/NT Low Arc Flash Circuit Breakers .....	236
Masterpact NW Low Arc Flash Circuit Breaker: L1F and LF .....	236
Masterpact NT Low Arc Flash Circuit Breaker: L1F and LF .....	236

# Masterpact™ NT and NW Universal Power Circuit Breakers Trip Curves

## Micrologic 6.0 A/P/H Trip Units

Figure 180: Micrologic 6.0 A/P/H Trip Units:  $I_n \leq 400$  A

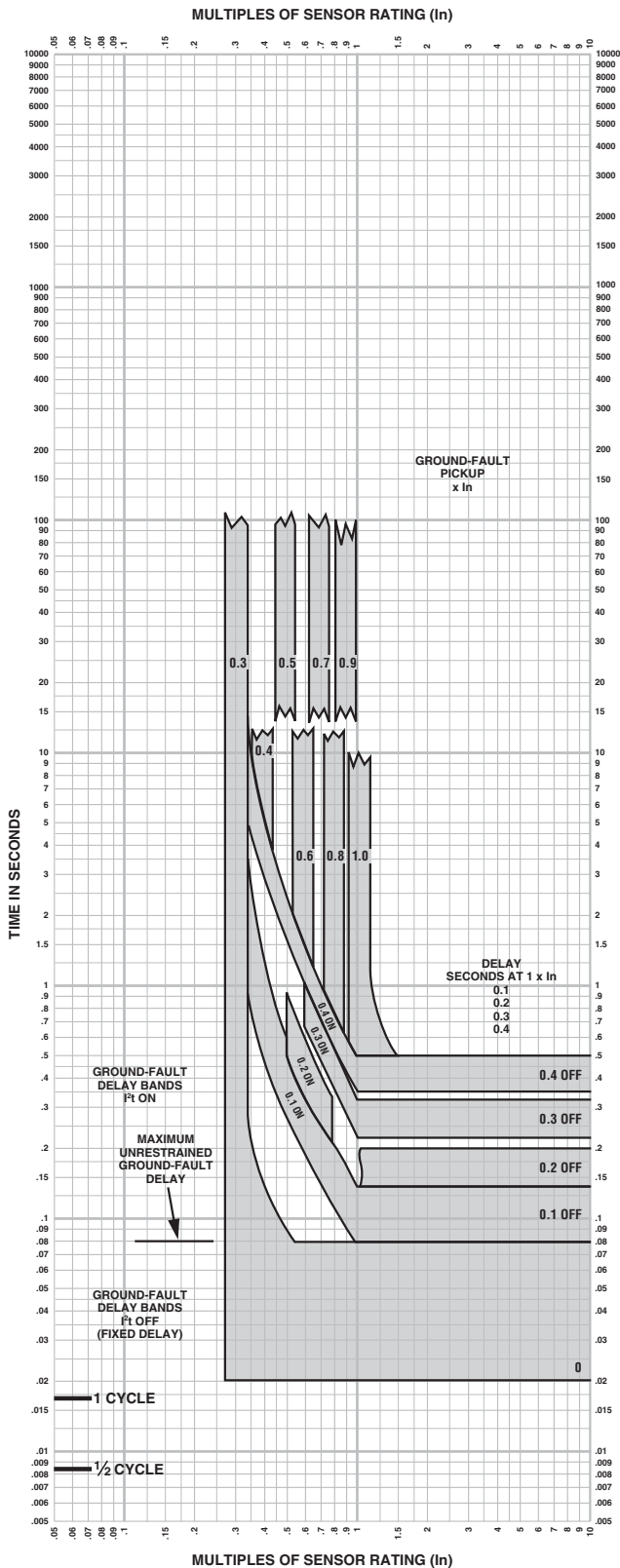

**Micrologic 6.0 A/P/H Trip Units  
with Adjustable Ground-Fault Pickup and Delay  
Characteristic Trip Curve No. 613-1  
Ground Fault  $I^2t$  OFF and ON  
 $I_n \leq 400$  A**

The time-current curve information is to be used for application and coordination purposes only.  
Curves apply from -25°C to +70°C (-13°F to +158°F) ambient temperature.

# Masterpact™ NT and NW Universal Power Circuit Breakers Trip Curves

**Figure 181: Micrologic 6.0 A/P/H Trip Units:  $400\text{ A} < I_n \leq 1200\text{ A}$**

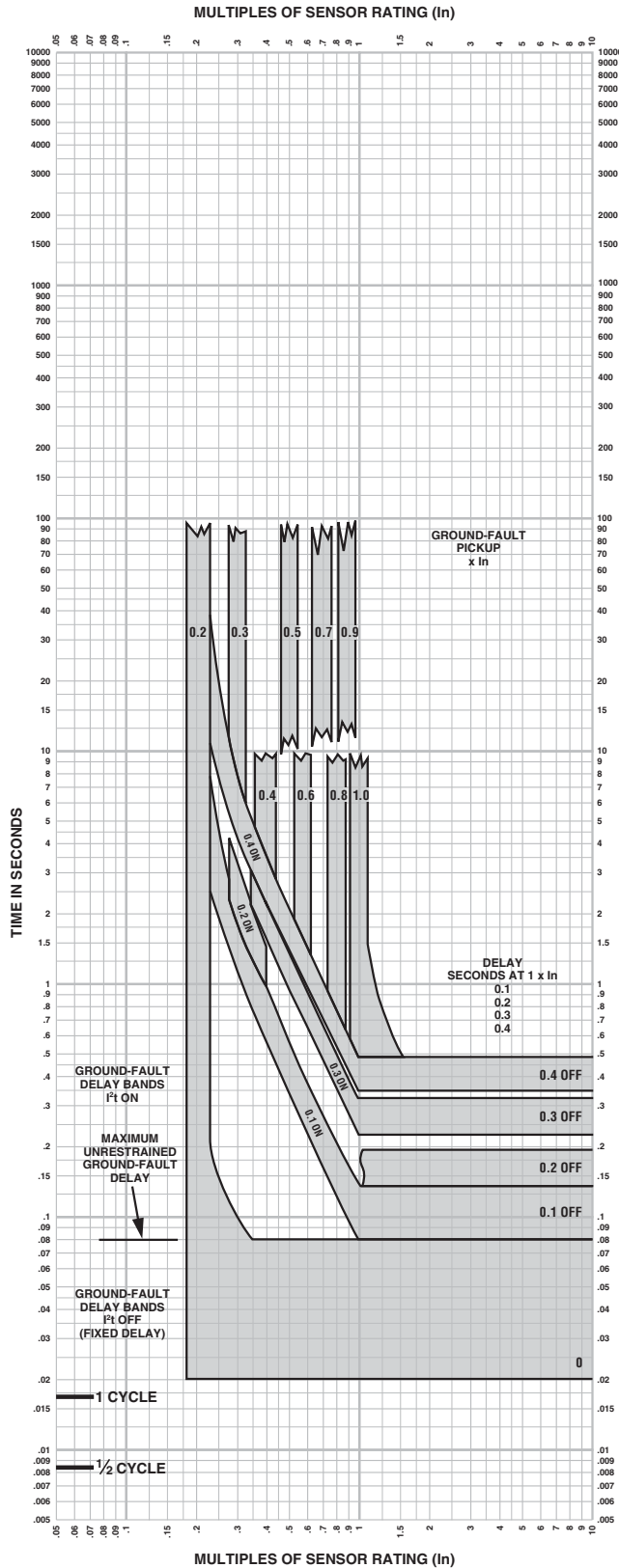

**Micrologic 6.0 A/P/H Trip Units  
with Adjustable Ground-Fault Pickup and Delay**

**Characteristic Trip Curve No. 613-2**

Ground Fault I<sup>2</sup>t OFF and ON  
400 A < I<sub>n</sub> ≤ 1200 A

The time-current curve information is to be used for application and coordination purposes only.  
Curves apply from 25°C to +70°C (-13°F to +158°F) ambient temperature.

# Masterpact™ NT and NW Universal Power Circuit Breakers Trip Curves

Figure 182: Micrologic 6.0 A/P/H Trip Units:  $I_n > 1200$  A

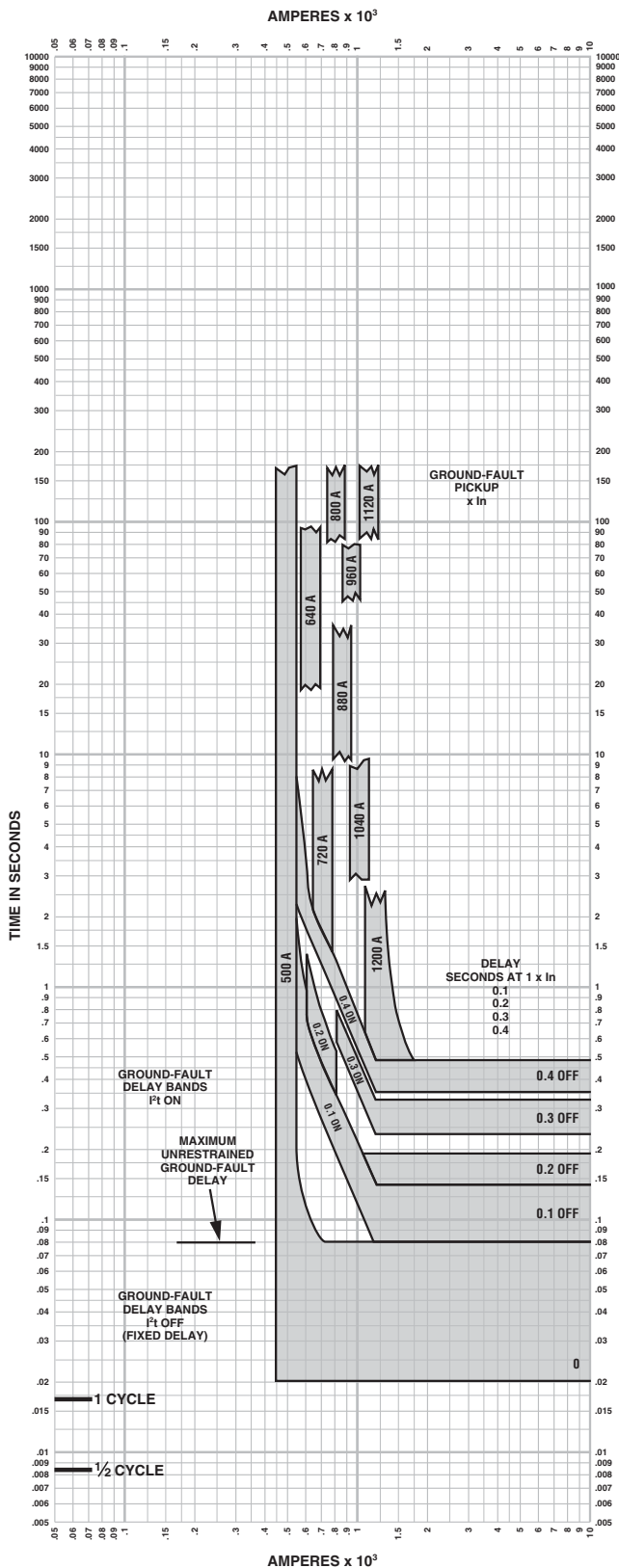

## Micrologic 6.0 A/P/H Trip Units with Adjustable Ground-Fault Pickup and Delay

### Characteristic Trip Curve No. 613-3

Ground Fault  $I^2t$  OFF and ON

$I_n > 1200$  A

The time-current curve information is to be used for application and coordination purposes only.

Curves apply from  $-25^{\circ}\text{C}$  to  $+70^{\circ}\text{C}$  ( $-13^{\circ}\text{F}$  to  $+158^{\circ}\text{F}$ ) ambient temperature.



# Masterpact™ NT and NW Universal Power Circuit Breakers Trip Curves

## Micrologic 5.0/6.0 A/P/H Trip Unit

**Figure 183: Micrologic 5.0/6.0 A/P/H Trip Units: Long-Time Pickup and Delay, Short-Time Pickup, and I<sup>2</sup>t OFF Delay**

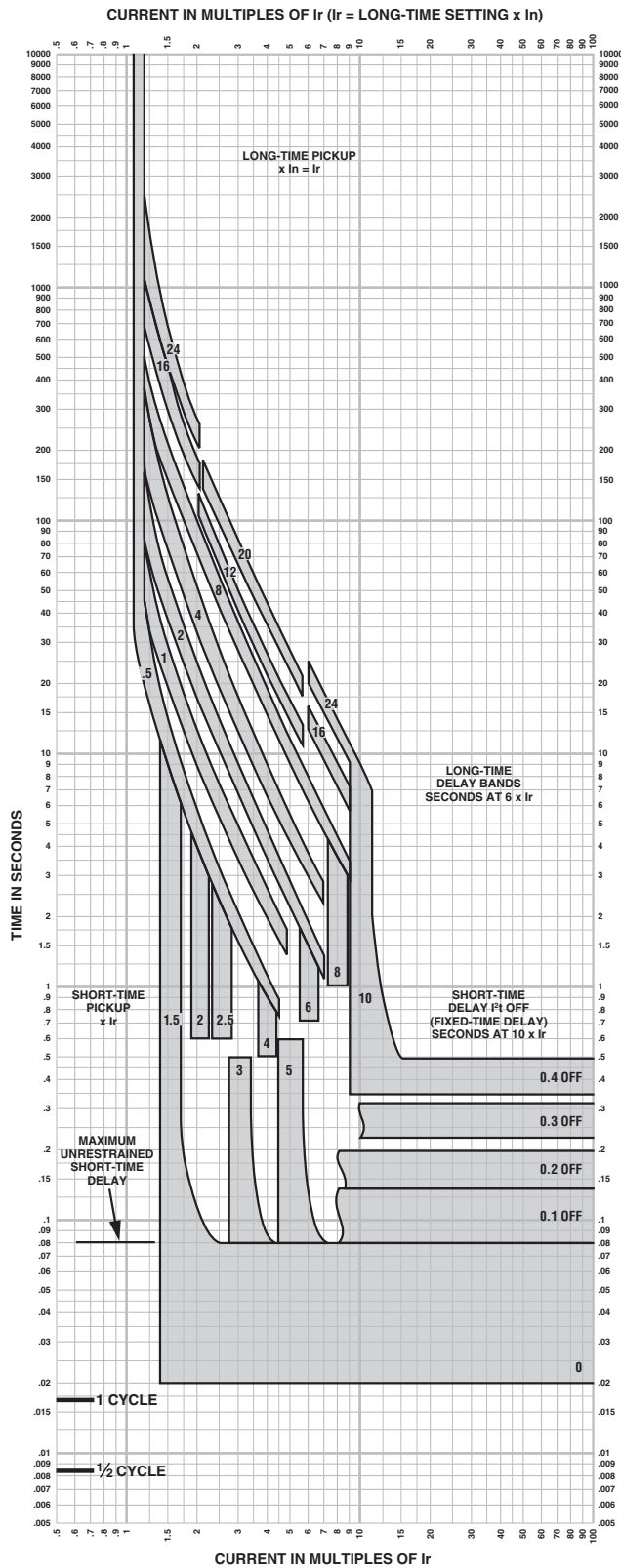

### Micrologic 5.0/6.0 A/P/H Trip Units Characteristic Trip Curve No. 613-4

Long-Time Pickup and Delay  
Short-Time Pickup and I<sup>2</sup>t OFF Delay

The time-current curve information is to be used for application and coordination purposes only.

Curves apply from -25°C to +70°C (-13°F to +158°F) ambient temperature.

**NOTE:**

1. There is a thermal-imaging effect that can act to shorten the long-time delay. The thermal-imaging effect comes into play if a current above the long-time delay pickup value exists for a time and then is cleared by the tripping of a downstream device or the circuit breaker itself. A subsequent overload will cause the circuit breaker to trip in a shorter time than normal. The amount of time delay reduction is inverse to the amount of time that has elapsed since the previous overload. Approximately twenty minutes is required between overloads to completely reset thermal-imaging.
2. The end of the curve is determined by the interrupting rating of the circuit breaker.
3. With zone-selective interlocking ON, short-time delay utilized, and no restraining signal, the maximum unrestrained short-time delay time band applies regardless of the setting.
4. Total clearing times shown include the response times of the trip unit, the circuit breaker opening, and the extinction of the current.
5. For a withstand circuit breaker, instantaneous can be turned OFF. See trip curve 613-7 for instantaneous trip curve. See trip curve 613-10 for instantaneous override values.
6. Overload indicator illuminates at 100%.

# Masterpact™ NT and NW Universal Power Circuit Breakers Trip Curves

Figure 184: Micrologic 5.0/6.0 A/P/H Trip Units: Short-Time Pickup and I<sup>2</sup>t ON Delay

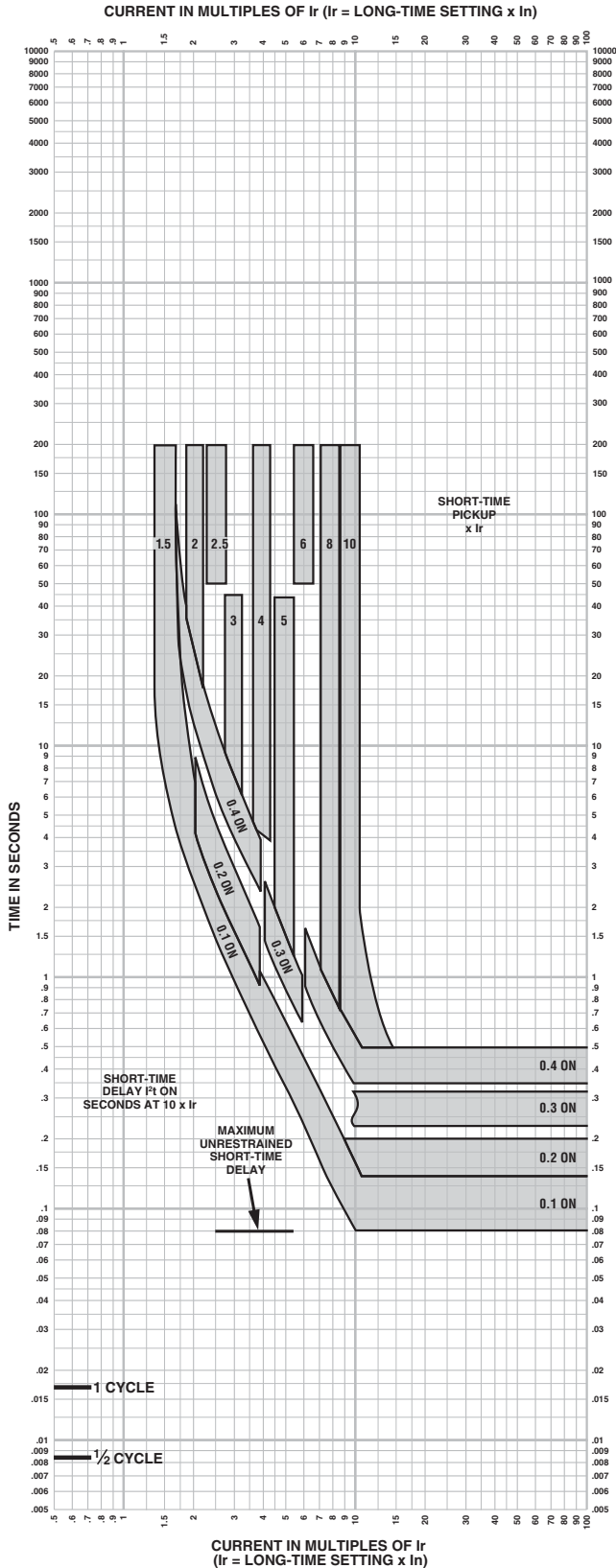

## Micrologic 5.0/6.0 A/P/H Trip Units Characteristic Trip Curve No. 613-5 Short-Time Pickup and I<sup>2</sup>t ON Delay

The time-current curve information is to be used for application and coordination purposes only.

Curves apply from -25°C to +70°C (-13°F to +158°F) ambient temperature.

### NOTE:

1. There is a thermal-imaging effect that can act to shorten the long-time delay. The thermal-imaging effect comes into play if a current above the long-time delay pickup value exists for a time and then is cleared by the tripping of a downstream device or the circuit breaker itself. A subsequent overload will cause the circuit breaker to trip in a shorter time than normal. The amount of time delay reduction is inverse to the amount of time that has elapsed since the previous overload. Approximately twenty minutes is required between overloads to completely reset thermal-imaging.
2. The end of the curve is determined by the interrupting rating of the circuit breaker.
3. With zone-selective interlocking ON, short-time delay utilized, and no restraining signal, the maximum unrestrained short-time delay time band applies regardless of the setting.
4. Total clearing times shown include the response times of the trip unit, the circuit breaker opening, and the extinction of current.
5. For withstand circuit breaker, instantaneous can be turned OFF. See trip curve 613-7 for instantaneous trip curve. See trip curve 613-10 for instantaneous override values.
6. See trip curve 613-4 for long-time pickup and delay trip curve.

# Masterpact™ NT and NW Universal Power Circuit Breakers Trip Curves

**Figure 185: Micrologic 5.0/6.0 Trip Units: Instantaneous Pickup, 2x to 15x and OFF**

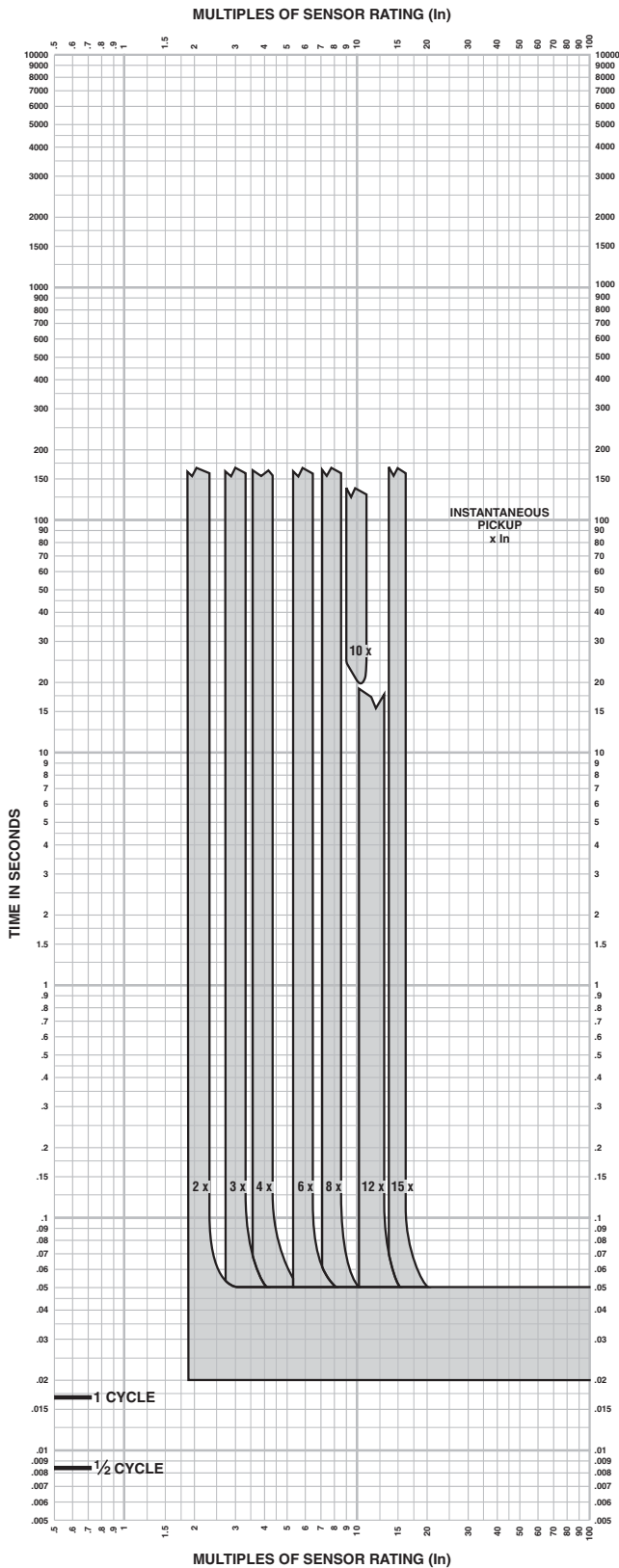

## Micrologic 5.0/6.0 A/P/H Trip Units Characteristic Trip Curve No. 613-7

Instantaneous Pickup  
2x–15x and OFF

The time-current curve information is to be used for application and coordination purposes only.

Curves apply from -25°C to +70°C (-13°F to +158°F) ambient temperature.

**NOTE:**

1. The end of the curve is determined by the interrupting rating of the circuit breaker.
2. Total clearing times shown include the response times of the trip unit, the circuit breaker opening, and the extinction of current.
3. The instantaneous region of the trip curve shows maximum total clearing times. Actual clearing times in this region can vary depending on the circuit breaker mechanism design and other factors. The actual clearing time can be considerably faster than indicated. Contact your local Sales Office for additional information.
4. For withstand circuit breaker, instantaneous can be turned OFF. See trip curve 613-10 for instantaneous override values.
5. See trip curve 613-4 and 613-5 for long-time pickup, long-time delay, short-time pickup, and short-time delay trip curve.

# Masterpact™ NT and NW Universal Power Circuit Breakers Trip Curves

## Micrologic 3.0 Trip Units

Figure 186: Micrologic 3.0A Trip Unit: Long-Time Pickup and Delay

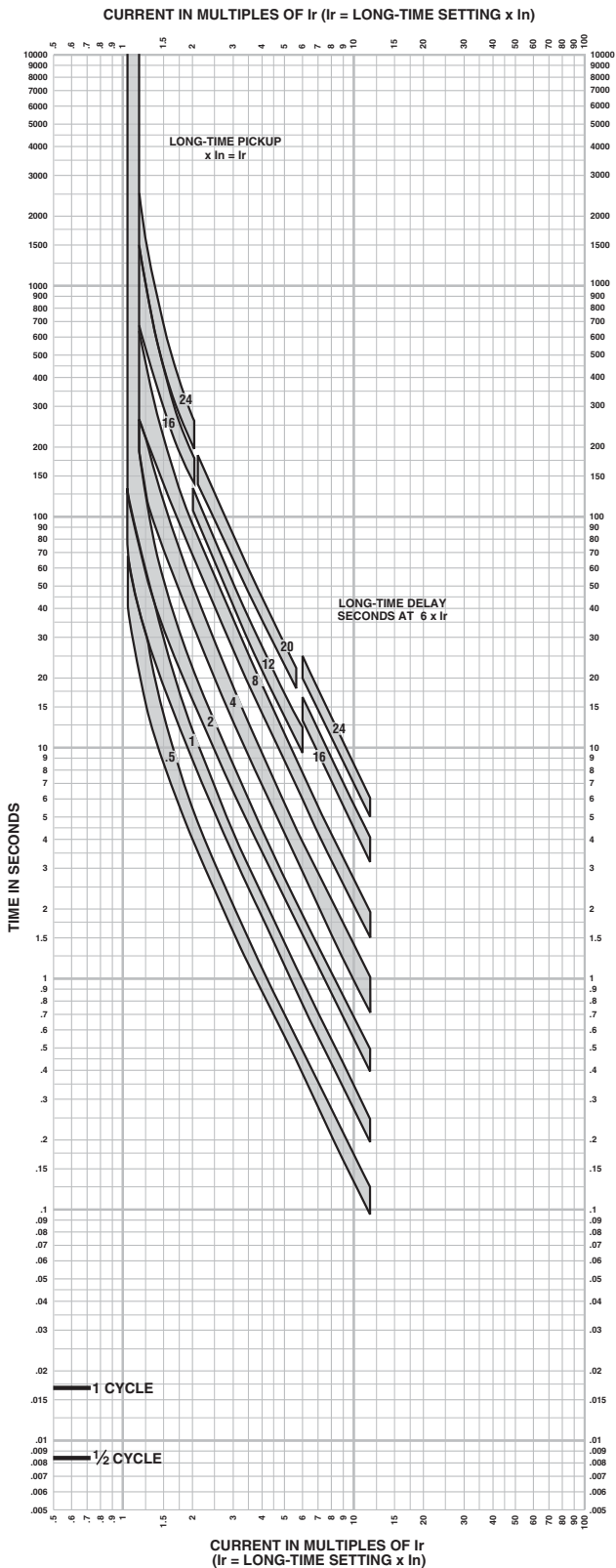

### Micrologic 3.0A Trip Unit Characteristic Trip Curve No. 613-6 Long-Time Pickup and Delay

The time-current curve information is to be used for application and coordination purposes only.

Curves apply from -30°C to +60°C (-22°F to +140°F) ambient temperature.

**NOTE:**

1. There is a thermal-imaging effect that can act to shorten the long-time delay. The thermal-imaging effect comes into play if a current above the long-time delay pickup value exists for a time and then is cleared by the tripping of a downstream device or the circuit breaker itself. A subsequent overload will cause the circuit breaker to trip in a shorter time than normal. The amount of time delay reduction is inverse to the amount of time that has elapsed since the previous overload. Approximately twenty minutes is required between overloads to completely reset thermal-imaging.
2. The end of the curve is determined by the instantaneous setting of the circuit breaker.
3. Total clearing times shown include the response times of the trip unit, the circuit breaker opening, and the extinction of current.
4. See trip curve 613-8 for instantaneous pickup trip curve.

# Masterpact™ NT and NW Universal Power Circuit Breakers Trip Curves

**Figure 187: Micrologic 3.0A Trip Unit: Instantaneous Pickup, 1.5X to 12X**

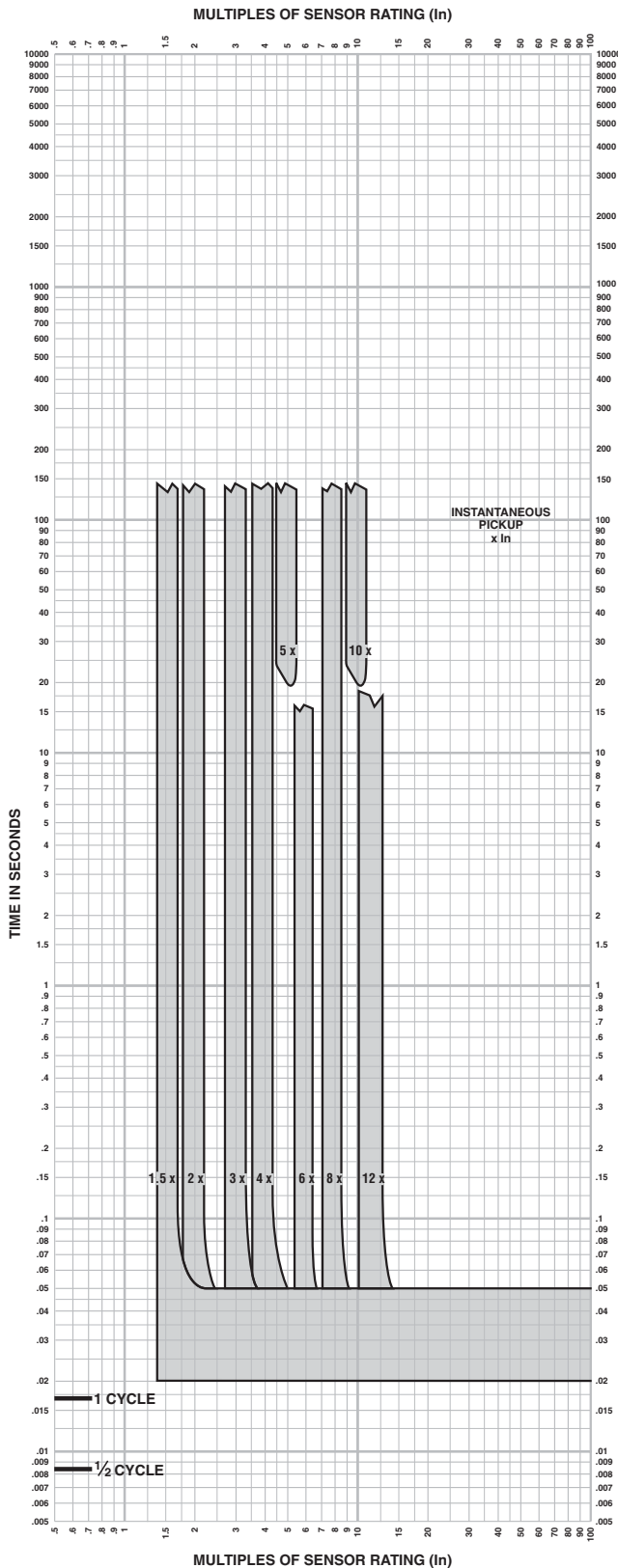

## Micrologic 3.0 A Trip Units Characteristic Trip Curve No. 613-8 Instantaneous Pickup 1.5x–12x

The time-current curve information is to be used for application and coordination purposes only.

Curves apply from -25°C to +70°C (-13°F to +158°F) ambient temperature.

Instantaneous override values are given on 613-10.

**NOTE:**

1. The end of the curve is determined by the interrupting rating of the circuit breaker.
2. Total clearing times shown include the response times of the trip unit, the circuit breaker opening, and the extinction of current.
3. The instantaneous region of the trip curve shows maximum total clearing times. Actual clearing times in this region can vary depending on the circuit breaker mechanism design and other factors. The actual clearing time can be considerably faster than indicated. Contact your local Sales Office for additional information.
4. See trip curve 613-6 for long-time pickup delay trip curve.

# Masterpact™ NT and NW Universal Power Circuit Breakers Trip Curves

Figure 188: Micrologic 2.0A Trip Unit

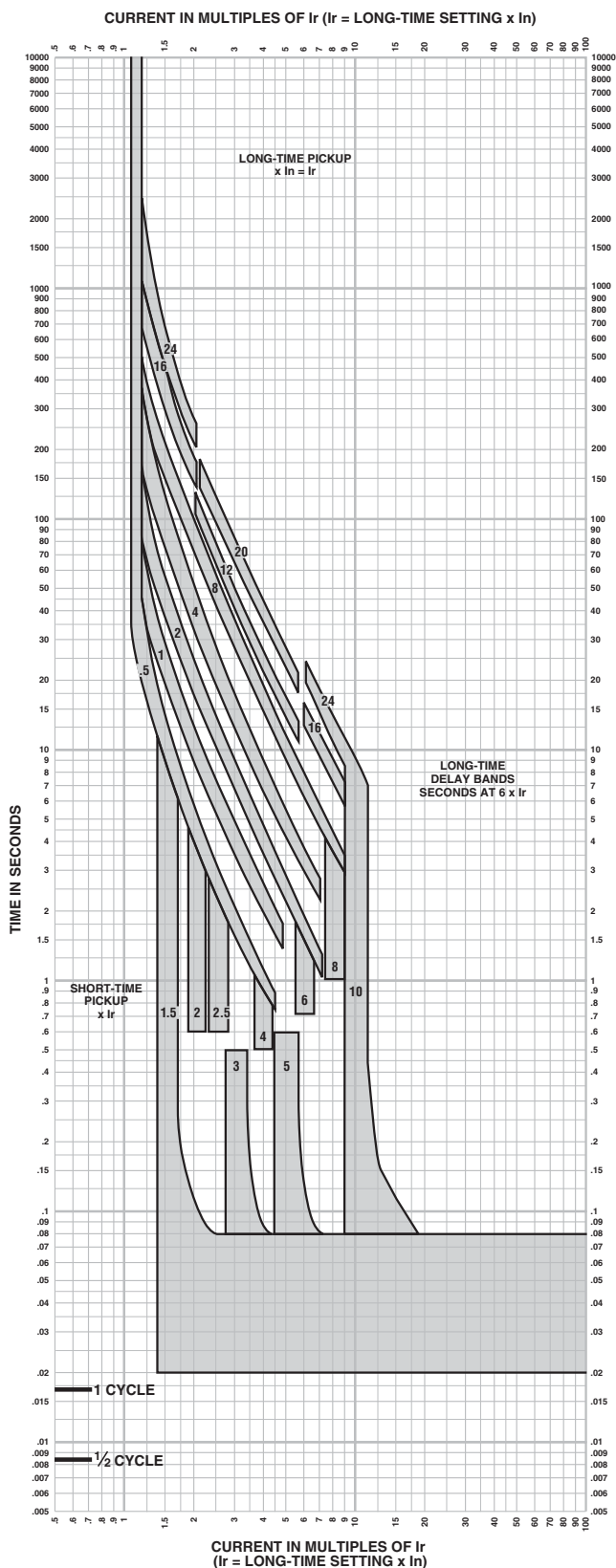

## Micrologic 2.0A Trip Unit Characteristic Trip Curve No. 613-9 Long-Time Pickup and Delay Short-Time Pickup with No Delay

The time-current curve information is to be used for application and coordination purposes only.

Curves apply from  $-25^{\circ}\text{C}$  to  $+70^{\circ}\text{C}$  ( $-13^{\circ}\text{F}$  to  $+158^{\circ}\text{F}$ ) ambient temperature.

### NOTE:

1. There is a thermal-imaging effect that can act to shorten the long-time delay. The thermal-imaging effect comes into play if a current above the long-time delay pickup value exists for a time and then is cleared by the tripping of a downstream device or the circuit breaker itself. A subsequent overload will cause the circuit breaker to trip in a shorter time than normal. The amount of time delay reduction is inverse to the amount of time that has elapsed since the previous overload. Approximately twenty minutes is required between overloads to completely reset thermal-imaging.
2. The end of the curve is determined by the short-time setting.
3. Total clearing times shown include the response times of the trip unit, the circuit breaker opening, and the extinction of current.
4. Overload indicator illuminates at 100%.

# Masterpact™ NT and NW Universal Power Circuit Breakers Trip Curves

Figure 189: Micrologic 2.0/3.0/5.0/6.0 A/P/H Trip Unit Instantaneous Override Values

## INSTANTANEOUS OVERRIDE VALUES NO. 613-10

MASTERPACT NW/NT		MASTERPACT NW/NT		MASTERPACT NW/NT		POWERPACT / COMPACT	
ANSI CB Model No.	Inst. Override (kA Peak) +/- 10%	UL CB Model No.	Inst. Override (kA Peak) +/- 10%	IEC CB Model No.	Inst. Override (kA Peak) +/- 10%	UL/IEC CB Model No.	Inst. Override (kA Peak) +/- 10%
NW08N1 ★	55	NW08N ★	55	NW08N1	None	RG600	130
NW08N1	None	NW08N	90	NW10N1	None	RG800	130
NW16N1	None	NW12N	90	NW12N1	None	RG1000	130
		NW16N	90	NW16N1	None	RG1200	130
NW08H1 ★	55	NW20N	90	NW08H1	None	RG1600	130
NW08H1	None	NW08H ★	55	NW10H1	None	RG2000	130
NW16H1	None	NW08H	90	NW12H1	None	RG2500	130
NW20H1	None	NW12H	90	NW16H1	None	RJ600	110▲
NW32H1	None	NW16H	90	NW20H1	None	RJ800	110▲
		NW20H	90	NW25H1	None	RJ1000	110▲
NW08H2 ★	55	NW25H	150	NW32H1	None	RJ1200	110▲
NW08H2	None	NW30H	150	NW40H1	None	RJ1600	110▲
NW16H2	None	NW40H	170	NW40bH1	None	RJ2000	110▲
NW20H2	None	NW50H	170	NW50H1	None	RJ2500	110▲
NW32H2	None	NW60H	170	NW63H1	None	RK600	130
NW40H2	None	NW08L ★	55	NW08H2 ★	55	RK800	130
NW50H2	None	NW08L	80	NW08H2	190	RK1000	130
NW60H2	None	NW08LF	55	NW10H2	190	RK1200	130
		NW12L	80	NW16H2	190	RK1600	130
NW08H3 ★	55	NW12LF	55	NW20H2	190	RK2000	130
NW08H3	190	NW16L	80	NW25H2	190	RK2500	130
NW16H3	190	NW16LF	55	NW32H2	190	RL600	110▲
NW20H3	190	NW20L	150	NW40H2	190	RL800	110▲
NW32H3	190	NW20LF	55	NW40bH2	190	RL1000	110▲
NW40H3	190	NW25L	150	NW50H2	270	RL1200	110▲
NW50H3	190	NW30L	150	NW63H2	270	RL1600	110▲
NW60H3	190	NW40L	170	NW20H3	150	RL2000	110▲
		NW50L	170	NW25H3	150	RL2500	110▲
NW08L1 ★	55	NW60L	170	NW32H3	150	PG250	55
NW08L1	80	NW08HF	90	NW40H3	150	PG400	55
NW08L1F	55	NW12HF	90	NW08L1 ★	55	PG600	55
NW16L1	80	NW16HF	90	NW08L1	80	PG800	55
NW16L1F	55	NW20HF	90	NW10L1	80	PG1000	55
NW20L1	80	NW25HF	150	NW12L1	80	PG1200	55
NW20L1F	55	NW30HF	150	NW16L1	80	PJ250	15
NW32L1	270	NW40HF	170	NW20L1	80	PJ400	22
NW40L1	270	NW50HF	170	NW08H10	None	PJ600	22
NW50L1	270	NW60HF	170	NW10H10	None	PJ800	22
NW60L1	270	NW08HB	80	NW12H10	None	PJ1000	22
NW08HA	None	NW12HB	80	NW16H10	None	PJ1200	22
NW16HA	None	NW16HB	80	NW20H10	None	PK250	55
NW20HA	None	NW20HB	150	NW25H10	None	PK400	55
NW32HA	None	NW25HB	150	NW32H10	None	PK600	55
NW40HA	None	NW30HB	150	NW40H10	None	PK800	55
NW50HA	None	NW40HB	170	NW08NA	None	PK1000	55
NW60HA	None	NW50HB	170	NW10NA	None	PK1200	55
		NW60HB	170	NW16NA	None	PL250	15
NW08HF	190	NT08N ★	55	NW08HA	None	PL400	22
NW16HF	190	NT08N	90	NW10HA	None	PL600	22
NW20HF	190	NT12N	90	NW12HA	None	PL800	22
NW32HF	190	NT16N	90	NW16HA	None	PL1000	22
NW40HF	190	NT08H ★	55	NW20HA	None	PL1200	22
NW50HF	190	NT08H	90	NW25HA	None	PK250	55
NW60HF	190	NT12H	90	NW32HA	None	PK400	55
		NT16H	90	NW40HA	None	PK600	55
NW08HC	80	NT08L1	22	NW40bHA	None	PK800	55
NW16HC	80	NT12L1	22	NW50HA	None	PK1000	55
NW20HC	80	NT16L1	22	NW63HA	None	PK1200	55
NW32HC	270	NT08L	22	NW08HF	190	NS800bN	130
NW40HC	270	NT08LF	22	NW10HF	190	NS1000bN	130
NW50HC	270	NT12L	22	NW12HF	190	NS1250bN	130
NW60HC	270	NT16L	22	NW16HF	190	NS1600bN	130
		NT12LF	22	NW20HF	190	NS2000N	130
NT08N1 ★	55	NT08HF	90	NW25HF	190	NS2500N	130
NT08N1	None	NT12HF	90	NW32HF	190	NS3200N	130
		NT16HF	90	NW40HF	190	NS800bH	110▲
NT08H1 ★	55			NW08HA10	None	NS1000bH	110▲
NT08H1	None			NW10HA10	None	NS1250bH	110▲
NT08L1F	22			NW12HA10	None	NS1600bH	110▲
				NW16HA10	None	NS2000H	110▲
NT08NA	None			NW20HA10	None	NS2500H	110▲
				NW25HA10	None	NS3200H	110▲
				NW32HA10	None	NS630bN	55
				NW40HA10	None	NS800N	55
				NT08H1	None	NS1000N	55
				NT10H1	None	NS1250N	55
				NT12H1	None	NS1600N	55
				NT16H1	None	NS630bH	55
				NT08L1	22	NS800H	55
				NT08H10	None	NS1000H	55
				NT10H10	None	NS1250H	55
				NT12H10	None	NS1600H	55
				NT16H10	None	NS630bL	55
				NT08HA	None	NS800L	55
				NT10HA	None	NS1000L	55
				NT12HA	None	NS1250L	55
				NT16HA	None	NS1600L	55
				NT08HA10	None		
				NT10HA10	None		
				NT12HA10	None		
				NT16HA10	None		

★ Maximum sensor plug 250 A

**Note:**  
Faults at or above instantaneous override value will be cleared at 25 msec or less.

▲ Tolerance +/- 15%

# Masterpact™ NT and NW Universal Power Circuit Breakers Trip Curves

## Masterpact NW/NT Low Arc Flash Circuit Breakers

Figure 190: Masterpact NW Low Arc Flash Circuit Breaker: L1F and LF

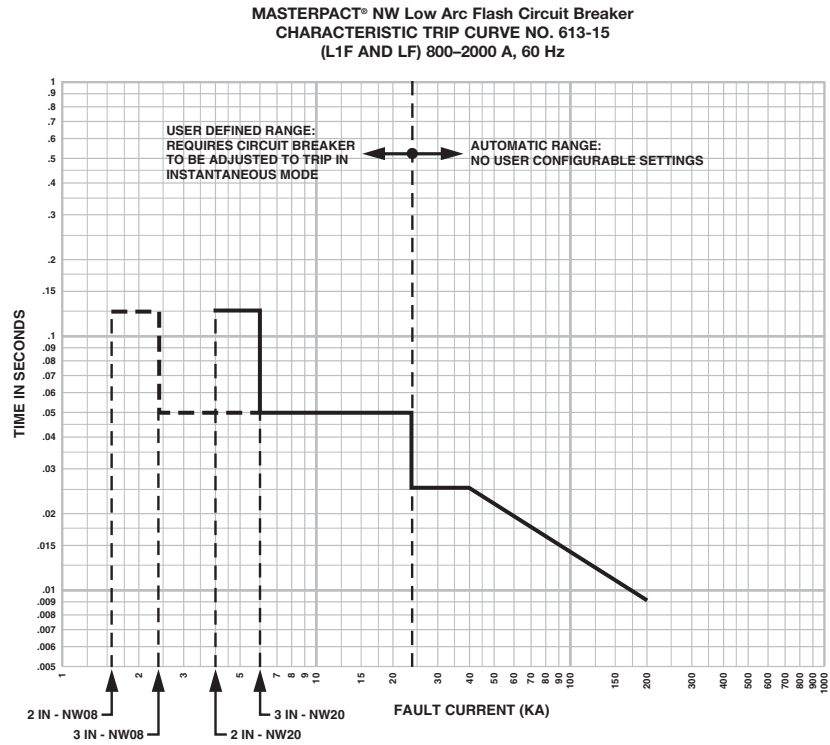
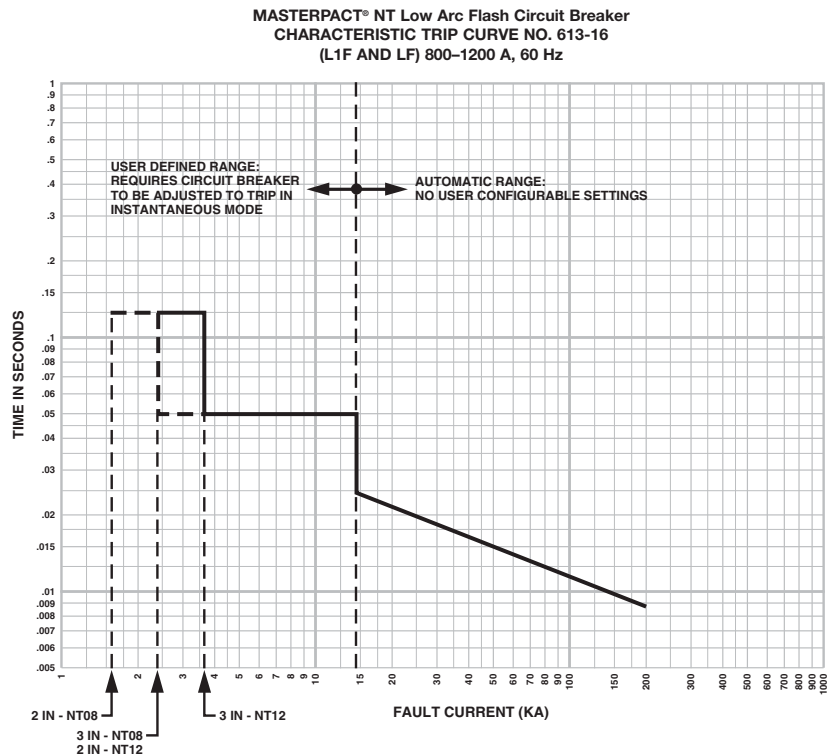

Figure 191: Masterpact NT Low Arc Flash Circuit Breaker: L1F and LF





# Masterpact™ NT and NW Universal Power Circuit Breakers Trip Curves





**Schneider Electric USA, Inc.**  
800 Federal Street  
Andover, MA 01810 USA  
888-778-2733  
[www.schneider-electric.us](http://www.schneider-electric.us)

© 2000–2015 Schneider Electric. All Rights Reserved  
Square D™, Schneider Electric™, Masterpact™, and Micrologic™ are trademarks owned by  
Schneider Electric Industries SAS or its affiliated companies. All other trademarks are the property  
of their respective owners.

0613CT0001 R07/15 Replaces 0613CT0001 R05/15

07/2015