

ConneXium Ethernet Switches

TCSESU0••F•N0 & TCSESU0103F2C•0 Quick Reference Guide

8/2014

NOTICE

Read these instructions carefully, and look at the equipment to become familiar with the device before trying to install, operate, or maintain it. The following special messages may appear throughout this documentation or on the equipment to warn of potential hazards or to call attention to information that clarifies or simplifies a procedure.



The addition of this symbol to a “Danger” or “Warning” safety label indicates that an electrical hazard exists which will result in personal injury if the instructions are not followed.



This is the safety alert symbol. It is used to alert you to potential personal injury hazards. Obey all safety messages that follow this symbol to avoid possible injury or death.

DANGER

DANGER indicates a hazardous situation which, if not avoided, **will result in** death or serious injury.

WARNING

WARNING indicates a hazardous situation which, if not avoided, **could result in** death or serious injury.

CAUTION

CAUTION indicates a hazardous situation which, if not avoided, **could result in** minor or moderate injury.

NOTICE

NOTICE is used to address practices not related to physical injury.

PLEASE NOTE

Electrical equipment should be installed, operated, serviced, and maintained only by qualified personnel. No responsibility is assumed by Schneider Electric for any consequences arising out of the use of this material.

A qualified person is one who has skills and knowledge related to the construction and operation of electrical equipment and its installation, and has received safety training to recognize and avoid the hazards involved.

Overview

Introduction

The ConneXium Ethernet switches discussed in this guide are specially designed to connect single devices or complete network segments in industrial environments. They support Ethernet 10 Mbit/s and Fast Ethernet 100 Mbit/s. The switch modules support switched Ethernet networks in accordance with IEEE standard 802.3 or 802.3u using copper and fiber optic technology. The switches are mounted on a standard DIN rail.

The switches discussed in this guide are described in the following table:

| Ethernet Switch | Copper Ports | Fiber Optic Ports | Fiber Optic Type |
|-----------------|--------------|-------------------|------------------|
| TCSESU033FN0 | 3 | 0 | - |
| TCSESU043F1N0 | 4 | 1 | multi-mode |
| TCSESU053FN0 | 5 | 0 | - |
| TCSESU083FN0 | 8 | 0 | - |
| TCSESU103F2CU0 | 8 | 2 | multi-mode |
| TCSESU103F2CS0 | 8 | 2 | single-mode |

Description

The twisted pair copper ports on all TCSESU0••F•N0 and TCSESU103F2C•0 switches support half/full duplex and 10/100 Mbit/s autonegotiation, autopolarity, and autocrossing.

The TCSESU033FN0 and TCSESU053FN0 switches are shown in the following figure:

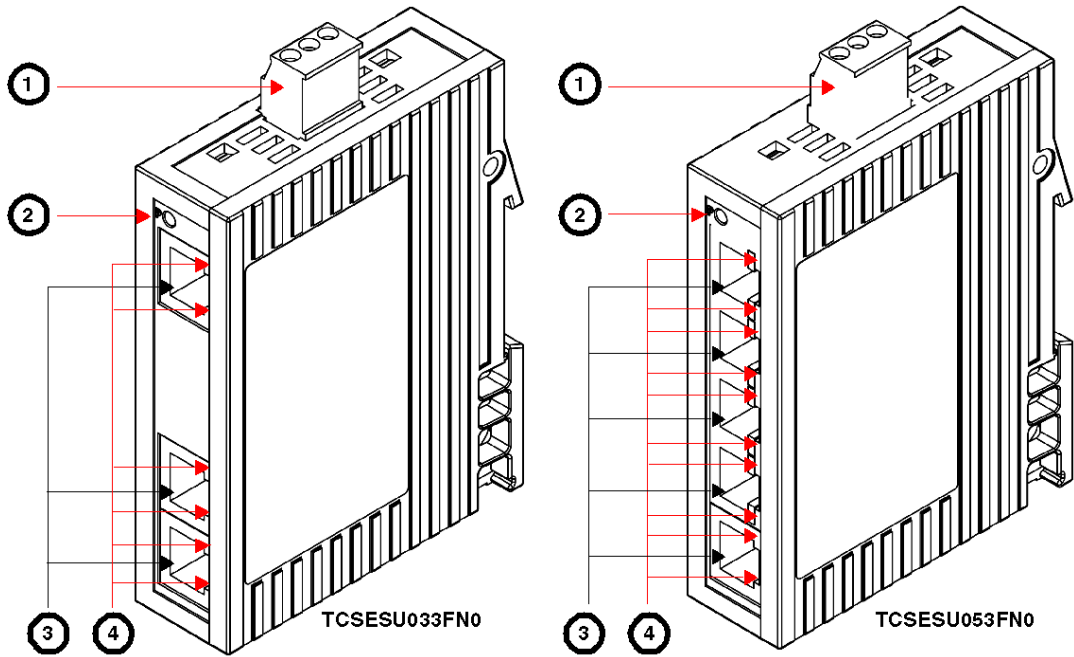

- 1 3-pin terminal block (for 24VDC power and PE ground)
- 2 power indicator
- 3 10/100 base-TX (RJ45 connectors)
- 4 port ACT/LNK LEDs

The fiber-enabled switches have four or eight copper ports and one or two 100 Mbit/s full duplex (FDX) fiber optic port (100 base-FX, duplex SC connector). You may connect one DTE or DCE device to each available port on the switch.

This illustration shows the 4-port TCSESU043F1N0 switch (left) and 8-port TCSESU083FN0, TCSESU103F2CU0, and TCSESU103F2CS0 switches (right):

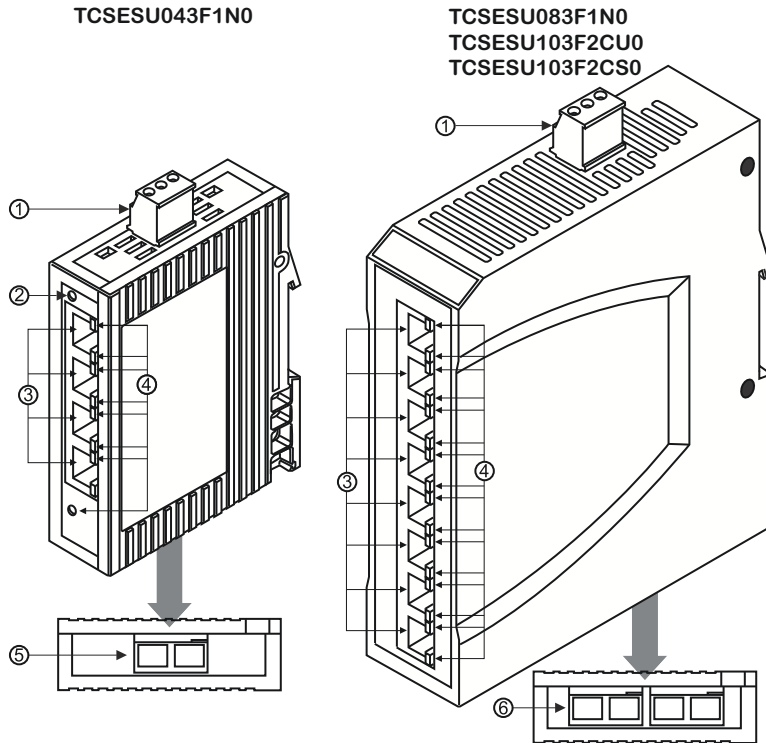

NOTE: Remove the rubber cover on the bottom of the switch to access the fiber-optic ports.

- 1 3-pin terminal block (for 24 VDC power and PE ground)
- 2 power indicator
- 3 10/100 base-TX (RJ-45) connectors
- 4 port ACT/LNK LEDs
- 5 100 base-FX (SC fiber connector) (TCSESU043F1N0 only, bottom view)
- 6 100 base-FX (2 SC fiber connectors) (TCSESU103F2CU0 and TCSESU103F2CS0 only, bottom view)

Features

Switching

Store and Forward

All data received by the ConneXium switches from all ports are stored and checked for validity. The switches discard the invalid frames (greater than 1,522 bytes or with CRC mismatches) and frame fragments (less than 64 bytes). The switches forward valid frames.

Multi-Address Capability

The switches learn source addresses on a per-port basis. Only packets with these addresses in the destination address field are sent to the ports:

- unknown addresses
- addresses learned at the specific port
- multicast and broadcast address

A switch can learn up to 1000 addresses. This feature is necessary if more than one terminal device is connected to one or more ports. Multi-address switching allows several independent subnetworks to be connected to a ConneXium switch.

The switches monitor the age of the learned addresses and delete entries from the address table that exceed a certain age (300 s).

NOTE: Restarting a switch (power cycle) deletes the learned address entries.

Tagging

Data packets with VLAN tags are transmitted unchanged by the switches (IEEE 802.1 Q).

TP/TX Interface

Link Control

The switches monitor the connected TP/TX line segments for short circuits and interrupts. They use regular link test pulses in accordance with IEEE standard 802.3 for 10/100 base-T. The switches do not transmit any data to a TP/TX segment from which they do not receive link test pulses.

NOTE: An unpopulated connection is assessed as a line interrupt. The TP/TX line to any terminal equipment that has been switched off is also assessed as a line interrupt since a de-energized bus coupler cannot transmit link test pulses.

Autopolarity Exchange

The switches automatically reverse polarity if the receive line pair is incorrectly connected (when + and - are switched).

Autonegotiation (10/100-TX RJ45 ports)

The switches automatically detect link connection speed up to 100 Mbit/s and half or full duplex.

Autocrossing

The switches detect the transmit and receive pairs (MDI, MDI-X). They automatically configure each port for the correct transmit and receive pins. Consequently, you can connect devices using either a crossover or straight cable.

F/O Interface

Link Control

The fiber optic port(s) on the switches monitor the connected F/O line for interrupts using idle signals during frame pauses (in accordance with IEEE standard 802.3 100 base-FX). The switches transmit data only to F/O lines from which they receive idle signal(s).

If the optical input power decreases below the low light threshold, the transmit and receive path is disabled for data, and the idle signal is transmitted.

Far-End Fault

The optical transmission distance(s) of both the single-mode and multi-mode F/O ports can be monitored in the receiving direction as well as in the transmitting direction, if the other side also supports far-end fault. If both sides do not support far-end fault, the optical transmission distance is monitored only in receiving direction.

The far-end fault is sent if the optical input power at the optical port has fallen under the low light level. If far-end fault is received, the link becomes inactive (the ACT/LNK LED is off).

Indicators

LEDs

LED display elements indicate the module status (power, data rate, and port status) of the ConneXium switches:

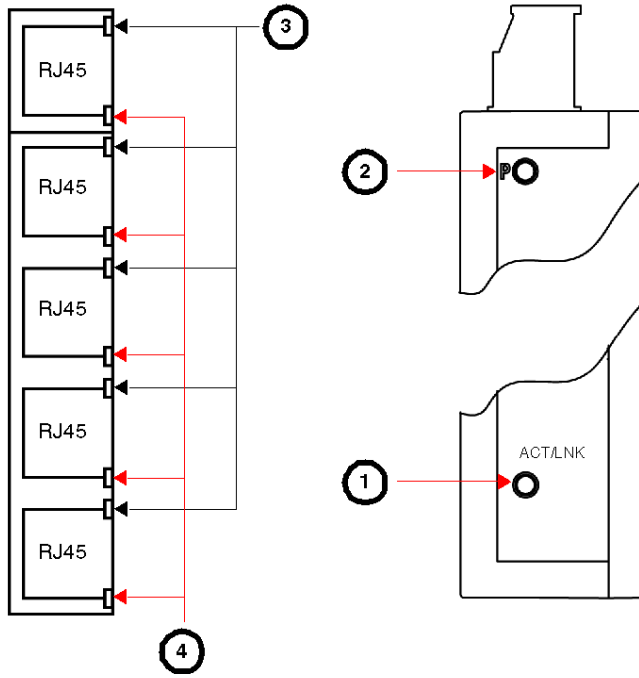

- 1 data, link status (fiber-enabled switch only)
- 2 power indicator
- 3 data rate (10/100 Mbit/s)
- 4 data, link status

The behavior of these LEDs is described in the following table:

| Indicator | Color | State | Meaning |
|-----------------|--------|----------|--|
| power indicator | green | on | power supply voltage is present |
| | | off | power supply voltage is less then 9.6 VDC |
| 10/100 Mbit/s | yellow | off | 10 Mbit/s link |
| | | on | 100 Mbit/s link |
| ACT/LNK 1...8 | green | off | no valid link is on the port |
| | | steady | link is valid and data is not being received |
| | | flashing | data is being sent or received |

Wiring

Ethernet Wiring

The 10/100 Mbit ports (eight-pin RJ45 sockets) on the ConneXium switches allow Ethernet devices, which comply with the standard IEEE 802.3 100 base-TX/10 base-T, to be connected. These ports support autonegotiation, autopolarity, and autocrossing.

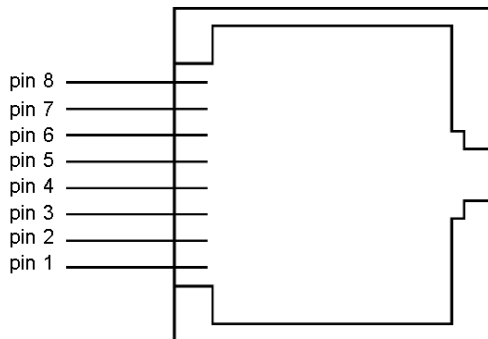

pins 3 and 6 provide pair 1
pins 1 and 2 provide pair 2
remaining pins are not used

The 10/100 Base-T(X) Connections

Each socket shield casing is electrically connected to the PE terminal (pin 3) on the 3-pin terminal block.

Ethernet Cables

For better noise immunity, use shielded Ethernet CAT5 or better grade cables, EIA568B pinout.

Fiber Wiring

Use fiber cables to improve the immunity to electrical noise and ground loops. The 100 Mbit/s fiber optic ports on these switches support the IEEE 802.3 100 base-FX FDX standard. They use duplex SC connectors. Each 100 Mbit/s fiber optic port allows the connection of an additional DTE or optical network component.

Voltage Supply

⚠ WARNING

HAZARD OF ELECTRIC SHOCK OR BURN

- When the module is operated with direct plug-in power units, use only:
 - SELV supply units that comply with IEC 60950/EN 60950
 - (in USA and Canada) Class 2 power units that comply with applicable National or Regional Electrical Codes
- Connect the ground wire (pin 3) reliably to a local ground before you establish any further connections.
- Connect the power supply wires to pins 1 and 2.
- The wire size for the PE terminal (pin 3) should not be smaller than 14 AWG (2 mm²) and must not exceed 12 AWG (3.3 mm²).
- The length of the PE ground wire should not exceed 3 meters.
- The wire size for the power supply terminals (pins 1 and 2) should not be smaller than 28 AWG (0.081 mm²) and must not exceed 12 AWG (3.3 mm²).
- When you remove connections from the switch, disconnect the ground wire last.

Failure to follow these instructions can result in death, serious injury, or equipment damage.

The supply voltage is electrically isolated from the housing.

Power Wiring

3-Pin Terminal Block

The supply voltage is connected to the switch via a 3-pin terminal block:

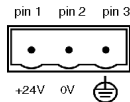

1. +24 VDC and 0V are isolated from the switch housing.
2. The 3-pin terminal block should be wired as follows:
 - a Power supply wires gauge/cross-sectional area (pins 1 and 2): between 12 AWG (3.3 mm²) and 28 AWG (0.081 mm²)
 - b PE ground wire gauge/cross-sectional area (pin 3): between 12 AWG (3.3 mm²) and 14 AWG (2 mm²)

Torque screws for power connections to 0.5 N-m (4.5 lbf-in).

NOTE: Use 60/75 or 75°C copper (CU) wire.

Application Example

Overview

The following figure shows the TCESU043F1N0 and TCESU053FN0 switches in an industrial Ethernet environment:

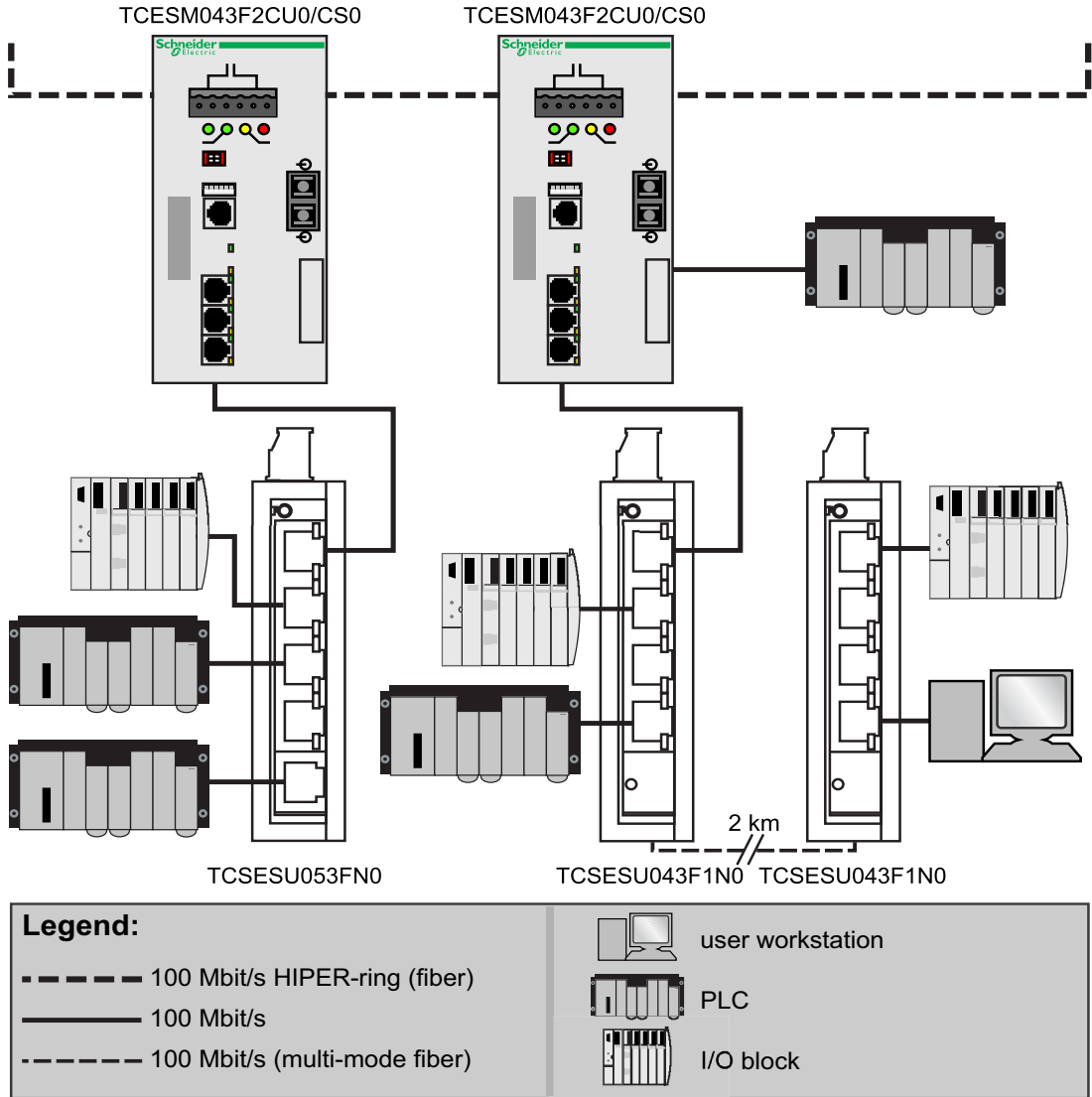

Installation

Installing

⚠ WARNING

POTENTIAL OF OVERHEATING AND LOSS OF COMMUNICATION

Do not cover the ventilation slots or otherwise inhibit the free circulation of air around them. The distance from any surface to the ventilation slots of the housing must be at least 4 in. (10 cm).

Failure to follow these instructions can result in death, serious injury, or equipment damage.

The equipment is delivered in ready-to-operate condition. Use the following procedure for appropriate installation.

NOTE: The ConneXium switch is designed as open equipment per EN 61131-2. Install the switch in an industry-standard enclosure to restrict access to authorized personnel.

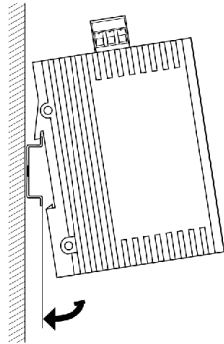
| Step | Action |
|--|---|
| 1 | Pull the 3-pin terminal block off the switch, and wire the power supply terminals (pins 1 and 2) and the PE ground terminal (pin 3). |
| 2 | Connect the other end of the ground wire to the best electrical ground available where the switch is to be located. For information on wire gauge/cross-sectional area, see the power wiring (see page 11) topic. |
| 3 | Reinstall the 3-pin terminal block on the switch. |
| 4 | Fit the switch on a 35 mm standard DIN EN 50 022 rail: <div style="text-align: center;">  </div> |
| 5 | Attach the upper snap-on slide bar on the module to the DIN rail, and press it down until it locks in position. |
| 6 | Install the Ethernet cables. |
| Note: Do not open the module housing, or you will violate the warranty. | |
| Note: This is a Class A device. This equipment may cause radio interference if it is used in a residential area. It is the operator's responsibility to take appropriate preventative measures. | |

Shielded Cable Ground Connection

The shielded Ethernet RJ45 socket casings are electrically connected to the PE terminal (pin 3) on the 3-pin terminal block.

NOTE: Verify that the electrical installation meets local safety regulations.

Removal

To take the ConneXium switch module off the ISO/DIN rail, insert a screwdriver horizontally under the right edge of the housing into the locking slide, pivot the screwdriver, and lift the module upward.

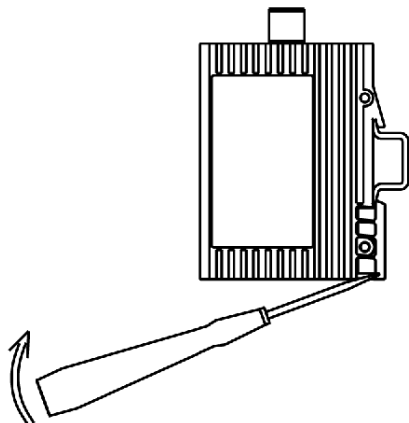

ConneXium Switch Specifications

General Data

| | | |
|----------------------------|---|---------------------------------------|
| Operating voltage | 9.6 - 32 VDC | |
| Supply type | NEC Class 2 SELV, 5A maximum | |
| Hold up time | Minimum 10 ms @ 20.4 VDC | |
| Power consumption @ 24 VDC | TCSESU033FN0 | 2.2 W maximum |
| | TCSESU043F1N0 | 3.9 W maximum |
| | TCSESU053FN0 | 2.2 W maximum |
| | TCSESU083FN0 | 4.1 W maximum |
| | TCSESU103F2CS0 | 8.4 W maximum |
| | TCSESU103F2CU0 | 8.4 W maximum |
| Dimensions (W x H x D) | TCSESU033FN0, TCSESU043F1N0, TCSESU053FN0 | 25 x 114 x 79 mm (1.0 x 4.5 x 3.2 in) |

| | | | |
|--|---------|---|---|
| | | TCSESU083FN0, TCSESU103F2CS0, TCSESU103F2CU0 | 35 x 138 x 121 mm (1.38 x 5.43 x 4.76 in) |
| Weight | | TCSESU033FN0 | 113 g (.25 lb) |
| | | TCSESU043F1N0 | 120 g (.27 lb) |
| | | TCSESU053FN0 | 113 g (.25 lb) |
| | | TCSESU083FN0 | 246 g (.54 lb) |
| | | TCSESU103F2CS0 | 260 g (.57 lb) |
| | | TCSESU103F2CU0 | 260 g (.57 lb) |
| Temperature | ambient | TCSESU033FN0, TCSESU043F1N0, TCSESU053FN0, TCSESU083FN0 | 0° C to 60° C (32° F...140° F) |
| | | TCSESU103F2CS0, TCSESU103F2CU0 | -40° C to 70° C (-40° F...+158° F) |
| | storage | TCSESU033FN0, TCSESU043F1N0, TCSESU053FN0, TCSESU083FN0 | -40° C to 70° C (-40° F...+158° F) |
| | | TCSESU103F2CS0, TCSESU103F2CU0 | -40° C to 85° C (-40° F...+185° F) |
| Shock and vibration protection | | IEC 60068-2-6, IEC 60068-2-27 | |
| Humidity | | up to 95% (noncondensing) | |
| Altitude | | up to 2,000 m | |
| Laser protection | | Class 1, conforming to EN60825-1 | |
| Enclosure | | IP 30 | |
| EMC | | Complies with requirements of EN61131-2. | |
| Mechanical/climatic | | Complies with requirements of EN61131-2. | |
| Radiated emissions | | Complies with requirements of EN55011A/CISPR11A. | |
| Approvals | | UL508, CSA 22.2, No. 142 | |
| Conforms to these Council Directives (for the European Economic Area market) | | LV. Standards to which conformity is declared: EN61131-2, EN60825-1, Class 1 laser. | |
| | | EMC. Standards to which conformity is declared: EN61131-2, EN55011. | |
| | | RoHS compliant. | |

Network Size

| | | | |
|--|--------------------------------|--------------------------------|------------|
| TP/TX port 10 base-T/100 base-TX | length of twisted pair segment | 100 m (328 ft) max. | |
| F/O port 100 base-FX - multi-mode (according to IEEE 802.3u 100 base-FX) | system attenuation | 50/125 mm fiber (multi-mode) | 0 to 8 dB |
| | | 62.5/125 mm fiber (multi-mode) | 0 to 11 dB |

| | | | |
|---|--------------------|-------------------------------|--------------------------------------|
| F/O port 100 base-FX - single-mode (according to IEEE 802.3u 100 base-FX) | system attenuation | 9/125 mm fiber (single-mode) | 0 to 16 dB |
| F/O line - multi-mode (example) | 50/125 mm fiber | 5 km (3.11 mi) (approx.) | data of fiber: 1.0 dB/km, 800 MHz*km |
| | 62.5/125 mm fiber | 4 km (2.49 mi) (approx.) | data of fiber: 1.0 dB/km, 500 MHz*km |
| F/O line - single-mode (example) | 9/125 mm fiber | 0/25 km (0/15.5 mi) (approx.) | 3.5 ps/(nm*km) |

Accessories

| Cable | Part | Available Lengths (m) |
|--|--------------|-----------------------|
| TF Ethernet SFTP CAT5 RJ45 cables | 490NTW000** | 2, 5, 12, 40, 80 |
| TF Ethernet SFTP CAT5 RJ45 crossed cables | 490NTC000** | 2, 5, 12, 40, 80 |
| Standard glass fiber optic adapter cable (1 sc connector, 1 MT-RJ connector) | 499NOC00005 | 5 |
| Ethernet M12-RJ45 CE light duty cables | TCSECL1M3M** | 1, 3, 10, 25, 40 |
| ** = length in meters | | |

Contact Information

Please find the nearest Schneider Electric sales office by visiting <http://www.schneider-electric.com>. Select your country in the drop-down menu to find customer support closest to you.



Select your country



* 3 1 0 0 7 9 5 0 0 4 *

Visit <http://www.schneider-electric.com> for your nearest Schneider Electric affiliate.

Printed in