

## Micro800 Plug-in Modules

Catalog Numbers 2080-IQ4, 2080-IQ40B4, 2080-IQ40V4, 2080-OB4, 2080-OV4, 2080-OW4I, 2080-IF2, 2080-IF4, 2080-OF2, 2080-TC2, 2080-RTD2, 2080-MEMBAK-RTC, 2080-TRIMPOT6, 2080-SERIALISOL, 2080-DNET20, 2080-MOT-HSC



## Important User Information

Solid-state equipment has operational characteristics differing from those of electromechanical equipment. Safety Guidelines for the Application, Installation and Maintenance of Solid State Controls (publication [SGL-1.1](#) available from your local Rockwell Automation sales office or online at <http://www.rockwellautomation.com/literature/>) describes some important differences between solid-state equipment and hard-wired electromechanical devices. Because of this difference, and also because of the wide variety of uses for solid-state equipment, all persons responsible for applying this equipment must satisfy themselves that each intended application of this equipment is acceptable.

In no event will Rockwell Automation, Inc. be responsible or liable for indirect or consequential damages resulting from the use or application of this equipment.

The examples and diagrams in this manual are included solely for illustrative purposes. Because of the many variables and requirements associated with any particular installation, Rockwell Automation, Inc. cannot assume responsibility or liability for actual use based on the examples and diagrams.

No patent liability is assumed by Rockwell Automation, Inc. with respect to use of information, circuits, equipment, or software described in this manual.

Reproduction of the contents of this manual, in whole or in part, without written permission of Rockwell Automation, Inc., is prohibited.

Throughout this manual, when necessary, we use notes to make you aware of safety considerations.



**WARNING:** Identifies information about practices or circumstances that can cause an explosion in a hazardous environment, which may lead to personal injury or death, property damage, or economic loss.



**ATTENTION:** Identifies information about practices or circumstances that can lead to personal injury or death, property damage, or economic loss. Attentions help you identify a hazard, avoid a hazard, and recognize the consequence



**SHOCK HAZARD:** Labels may be on or inside the equipment, for example, a drive or motor, to alert people that dangerous voltage may be present.



**BURN HAZARD:** Labels may be on or inside the equipment, for example, a drive or motor, to alert people that surfaces may reach dangerous temperatures.

---

**IMPORTANT** Identifies information that is critical for successful application and understanding of the product.

---

Allen-Bradley, Rockwell Software, Rockwell Automation, Micro800, Micro820, Micro830, Micro850, Kinetix, PowerFlex, CompactBlock, KwikLink, Connected Components Workbench, and TechConnect are trademarks of Rockwell Automation, Inc.

Trademarks not belonging to Rockwell Automation are property of their respective companies.

Read this preface to familiarize yourself with the rest of the manual. It provides information concerning:

- who should use this manual
- the purpose of this manual
- related documentation
- supporting information for Micro800™ plug-in modules and accessories

## Who Should Use this Manual

Use this manual if you are responsible for designing, installing, programming, or troubleshooting control systems that use Micro800 controllers.

You should have a basic understanding of electrical circuitry and familiarity with relay logic. If you do not, obtain the proper training before using this product.

## Purpose of this Manual

This manual is a reference guide for Micro800 controllers, plug-in modules and accessories. It describes the procedures you use to install, wire, and troubleshoot your controller. This manual:

- explains how to install and wire your plug-ins
- gives you an overview of the Micro800 plug-in modules and accessories

Refer to the additional resources for more information on other element of the Micro800 system.

## Additional Resources

These documents contain additional information concerning related Rockwell Automation products.

Resource	Description
Micro800 Programmable Controller External AC Power Supply Installation Instructions <a href="#">2080-IN001</a>	Information on mounting and wiring the optional external power supply.
Micro830 Programmable Controllers Installation Instructions <a href="#">2080-IN002</a>	Information on mounting and wiring the Micro830 10-point controllers.
Micro830 Programmable Controllers Installation Instructions <a href="#">2080-IN003</a>	Information on mounting and wiring the Micro830 16-point controllers.
Micro830 Programmable Controllers Installation Instructions <a href="#">2080-IN004</a>	Information on mounting and wiring the Micro830 24-point controllers.
Micro830 Programmable Controllers Installation Instructions <a href="#">2080-IN005</a>	Information on mounting and wiring the Micro830 48-point controllers.
Micro850 Programmable Controllers Installation Instructions <a href="#">2080-IN007</a>	Information on mounting and wiring the Micro850 24-point controllers.
Micro850 Programmable Controllers Installation Instructions <a href="#">2080-IN008</a>	Information on mounting and wiring the Micro850 48-point controllers.
Micro820 Programmable Controllers Installation Instructions <a href="#">2080-IN009</a>	Information on mounting and wiring the Micro820 20-point controllers.
Micro800 Remote LCD Installation Instructions <a href="#">2080-IN010</a>	Information on mounting and wiring the Micro800 Remote LCD module.

Resource	Description
Micro800 RS232/485 Isolated Serial Port Plug-in Module Wiring Diagrams <a href="#">2080-WD002</a>	Information on mounting and wiring the Micro800 RS232/485 isolated serial port plug-in module.
Micro800 Non-isolated Unipolar Analog Input Plug-in Module Wiring Diagrams <a href="#">2080-WD003</a>	Information on mounting and wiring the Micro800 non-isolated unipolar analog input plug-in module.
Micro800 Non-isolated Unipolar Analog Output Plug-in Module Wiring Diagrams <a href="#">2080-WD004</a>	Information on mounting and wiring the Micro800 non-isolated unipolar analog output plug-in module.
Micro800 Non-isolated RTD Plug-in Module Wiring Diagrams <a href="#">2080-WD005</a>	Information on mounting and wiring the Micro800 non-isolated RTD plug-in module.
Micro800 Non-isolated Thermocouple Plug-in Module Wiring Diagrams <a href="#">2080-WD006</a>	Information on mounting and wiring the Micro800 non-isolated thermocouple plug-in module.
Micro800 Memory Backup and High Accuracy RTC Plug-In Module Wiring Diagrams <a href="#">2080-WD007</a>	Information on mounting and wiring the Micro800 memory backup and high accuracy RTC plug-in module.
Micro800 6-Channel Trimptot Analog Input Plug-In Module Wiring Diagrams <a href="#">2080-WD008</a>	Information on mounting and wiring the Micro800 6-channel trimptot analog input plug-in module.
Micro800 Digital Relay Output Plug-in Module Wiring Diagrams <a href="#">2080-WD010</a>	Information on mounting and wiring the Micro800 digital relay output plug-in module.
Micro800 Digital Input, Output, and Combination Plug-in Modules Wiring Diagrams <a href="#">2080-WD011</a>	Information on mounting and wiring the Micro800 digital input, output, and combination plug-in module.
Micro800 High-speed Counter Plug-in Module <a href="#">2080-WD012</a>	Specifications and information on wiring the Micro800 high-speed counter plug-in module.
Micro800 DeviceNet Plug-in Module <a href="#">2080-WD013</a>	Specifications and information on wiring the Micro800 DeviceNet plug-in module.
Micro820 Programmable Controller User Manual, publication <a href="#">2080-UM005</a>	Information on features, installation, wiring and usage of the Micro820 controllers.
Micro830 and Micro850 Programmable Controller User Manual, publication <a href="#">2080-UM002</a>	Information on features, installation, wiring and usage of the Micro830 and Micro850 controllers.
Industrial Automation Wiring and Grounding Guidelines, publication <a href="#">1770-4.1</a>	Provides general guidelines for installing a Rockwell Automation industrial system.
Product Certifications website, <a href="http://www.rockwellautomation.com/products/certification/">http://www.rockwellautomation.com/products/certification/</a>	Provides declarations of conformity, certificates, and other certification details.
Application Considerations for Solid-State Controls <a href="#">SGI-1.1</a>	A description of important differences between solid-state programmable controller products and hard-wired electromechanical devices.
National Electrical Code - Published by the National Fire Protection Association of Boston, MA.	An article on wire sizes and types for grounding electrical equipment.
Allen-Bradley Industrial Automation Glossary <a href="#">AG-7.1</a>	A glossary of industrial automation terms and abbreviations.

You can view or download publications at <http://www.rockwellautomation.com/literature/>. To order paper copies of technical documentation, contact your local Rockwell Automation distributor or sales representative.

You can download the latest version of Connected Components Workbench for your Micro800 at the URL below.

<http://ab.rockwellautomation.com/Programmable-Controllers/Connected-Components-Workbench-Software>.



<b>Preface</b>	Who Should Use this Manual ..... iii Purpose of this Manual ..... iii Additional Resources ..... iii
<b>Chapter 1</b>	
<b>Micro800 Plug-in Modules</b>	Digital Plug-ins ..... 2 12/24V Digital Plug-ins — 2080-IQ4, 2080-IQ4OB4, 2080-IQ4OV4, 2080-OB4, 2080-OV4 ..... 2 AC/DC Relay Output Module — 2080-OW4I ..... 3 Analog Plug-ins ..... 3 Non-isolated Unipolar Analog Input and Output — 2080-IF2, 2080-IF4, 2080-OF2 ..... 3 Specialty Plug-ins ..... 3 Non-isolated Thermocouple and RTD — 2080-TC2 and 2080-RTD2 ..... 3 Memory Backup and High Accuracy RTC — 2080-MEMBAK-RTC ..... 3 Six-channel Trimpot — 2080-TRIMPOT6 ..... 4 High Speed Counter — 2080-MOT-HSC ..... 4 Communication Plug-ins ..... 4 RS232/RS485 Isolated Serial Port — 2080-SERIALISOL ..... 4 DeviceNet Scanner — 2080-DNET20 ..... 5
<b>Chapter 2</b>	
<b>Install and Wire Your Module</b>	Hardware Features ..... 7 Insert Module into Controller ..... 7 Wiring ..... 8 Wiring Considerations and Applications for 2080-TC2 ..... 12 Type of CJC Sensor ..... 12 Wire the CJC Thermistor on the 2080-TC2 Module ..... 12 Wiring Considerations and Applications for 2080-RTD2 ..... 13 Two-wire and Three-Wire Wiring ..... 13 Wire the RTD Sensors ..... 13 Wire the RTD Module and RTD Sensor in the Field ..... 14 Wiring Applications for 2080-MOT-HSC ..... 16
<b>Chapter 3</b>	
<b>Non-isolated Thermocouple and RTD Plug-in Modules – 2080-TC2 and 2080-RTD2</b>	Thermocouple Module ..... 19 Thermocouple Sensor Types and Ranges ..... 19 RTD Module ..... 20 RTD Sensor Types and Ranges ..... 20 Connected Components Workbench Global Variables Data Maps ..... 22 Temperature Conversion – Data to Degree Celsius (°C) ..... 23

<b>High Speed Counter – 2080-MOT-HSC</b>	<b>Chapter 4</b>	
	Overview .....	25
	Counter Specifications.....	25
	Number of Counters: 1 to 2 .....	26
	Up Counter.....	27
	Counter with External Direction.....	28
	Understanding Rates.....	33
	User Defined Function Blocks.....	35
	RA_HSCPlugIn.....	35
	Use the 2080-MOT-HSC Module.....	38
<b>DeviceNet Plug-in – 2080-DNET20</b>	<b>Chapter 5</b>	
	Overview .....	39
	Status Indicators .....	39
	Network Configuration.....	40
	Network Wiring.....	40
	DeviceNet Switches.....	41
	Power Supply.....	42
	User Defined Function Blocks.....	45
	RA_DNET_MASTER .....	45
	RA_DNET_NODE_STATUS.....	46
	RA_DNET_LDX_DISCRETE .....	47
	RA_DNET_LDX_ANALOG .....	48
	RA_DNET_LDX_TC_RTD .....	49
	RA_PF_DNET_STANDARD.....	50
	RA_PF_DNET_MULTIDRIVE.....	51
	RA_DNET_OVERLOAD.....	53
	RA_DNET_GENERIC .....	53
	Send Explicit Messages to 2080-DNET20 Plug-in Using Micro800 Pass Through.....	56
	Error Codes.....	57
	Use the 2080-DNET20 Plug-in.....	58
<b>Specifications</b>	<b>Appendix A</b>	
	Digital Plug-in Modules.....	59
	Analog Plug-in Modules .....	64
	Specialty Plug-in Modules.....	66
	Communication Plug-in Modules .....	73
<b>Quickstart</b>	<b>Appendix B</b>	
	Add and Configure Plug-ins in Connected Components Workbench.....	79
	Browse Your 2080-DNET20 Plug-in Using RSLinx.....	81
	Browse Using the DeviceNet Network .....	82
	Browse Using the Micro800 Pass Through .....	83

Flash Upgrade Your 2080-DNET20 Plug-in Firmware .....	84
Quickstart Project for 2080-DNET20 Plug-in .....	88
Setup and Wiring .....	89
Configuration .....	90
Build and Download .....	92
Execute Program .....	93
Quickstart Projects for 2080-MOT-HSC Plug-in .....	93
Setup and Wiring .....	94
Configuration for UDFB 1: RA_HSCPlugIn .....	95
Build and Download .....	96
Execute the Function Block .....	96
Configuration for UDFB 2: RA_EncoderFDBK .....	97
Build and Download .....	98
Execute the Function Block .....	99
Configuration for HSC UDFB 3: RA_ServoFDBK .....	100
Build and Download .....	101
Execute the Function Block .....	102

## Appendix C

### Error Codes

Troubleshooting .....	105
Error Codes for Micro800 Plug-ins .....	105
Calling Rockwell Automation for Assistance .....	106

### Index

**Notes:**

## Micro800 Plug-in Modules



Plug-in modules enhance the functionality of a base unit controller. With these modules, you can:

- Extend the functionality of embedded I/O without increasing the footprint of your controller.
- Improve performance by adding additional processing power or capabilities.
- Add additional communication functionality.

Micro820, Micro830, and Micro850 support the following plug-in modules:

### Micro800 Plug-in Modules

Module	Type	Description
2080-IQ4	Digital	4-point, 12/24V DC Sink/Source input
2080-IQ4OB4	Digital	8-point, Combo, 12/24V DC Sink/Source input 12/24V DC Source output
2080-IQ4OV4	Digital	8-point, Combo, 12/24V DC Sink/Source input 12/24V DC Sink output
2080-OB4	Digital	4-point, 12/24V DC Source output
2080-OV4	Digital	4-point, 12/24V DC Sink output
2080-OW4I	Digital	4-point, AC/DC Relay output
2080-IF2	Analog	2-channel, Non-isolated unipolar voltage/current analog input
2080-IF4	Analog	4-channel, Non-isolated unipolar voltage/current analog input



**Micro800 Plug-in Modules**

Module	Type	Description
2080-OF2	Analog	2-channel, Non-isolated unipolar voltage/current analog output
2080-TC2	Specialty	2-channel, non-isolated thermocouple module
2080-RTD2	Specialty	2-channel, non-isolated RTD module
2080-MEMBAK-RTC <sup>(1)</sup>	Specialty	Memory backup and high accuracy RTC
2080-TRIMPOT6	Specialty	6-channel trimpot analog input
2080-MOT-HSC	Specialty	High speed counter
2080-DNET20	Communication	20-node DeviceNet scanner
2080-SERIALISOL	Communication	RS232/485 isolated serial port

(1) 2080-MEMBAK-RTC is not supported on Micro820 controllers.

Number of support for Micro800 plug-ins on the controllers are summarized in the following table.

**Plug-in Slots on Micro800 Controllers**

Controller	Number of Plug-in Slots
Micro810	0
Micro820	2
Micro830	2 (10/16 points) 3 (24 points) 5 (48 points)
Micro850	3 (24 points) 5 (48 points)



**ATTENTION:** Removal and Insertion Under Power (RIUP) is not supported on all Micro800 plug-in modules, except on the 2080-MEMBAK-RTC module.



**ATTENTION:** Micro800 plug-in modules can be installed on any plug-in slot on the controller, except for the 2080-MEMBAK-RTC module which can only be installed on the leftmost plug-in slot.

**Digital Plug-ins**

**12/24V Digital Plug-ins — 2080-IQ4, 2080-IQ40B4, 2080-IQ40V4, 2080-OB4, 2080-OV4**

These digital plug-in modules provide transistor outputs for switching a variety of 12/24V DC voltages to field loads and for detecting 12/24V signals from field devices.

## **AC/DC Relay Output Module — 2080-OW4I**

The 2080-OW4I is a 4-channel relay output and provides dry contact relay closure outputs for switching a variety of AC and DC voltages to field loads.

## **Analog Plug-ins**

The following analog plug-ins are supported by most Micro800 controllers.

### **Non-isolated Unipolar Analog Input and Output — 2080-IF2, 2080-IF4, 2080-OF2**

These plug-in modules add extra embedded non-isolated unipolar (0...10V, 0...20 mA) analog I/O and offer 12-bit resolution.

## **Specialty Plug-ins**

### **Non-isolated Thermocouple and RTD — 2080-TC2 and 2080-RTD2**

These non-isolated plug-in modules help to make temperature control possible when used with PID (Proportional Integral Derivative).

See [Non-isolated Thermocouple and RTD Plug-in Modules – 2080-TC2 and 2080-RTD2 on page 19](#) for more information.

### **Memory Backup and High Accuracy RTC — 2080-MEMBAK-RTC**

This plug-in allows you to make a backup copy of the project in your controller, and adds precision real-time clock function without needing to calibrate or update periodically.

It can also be used to clone/update Micro830 and Micro850 application code. However, it cannot be used as additional Run-Time Program or Data Storage for recipe and datalog.

### Status Indicators

State	Description
Solid red (2 s)	Startup cycle test in progress.
Flashing red	Back up in progress.
Solid red (continuous)	Battery low.

### Project Backup and Restore

The project can be backed up and restored using Connected Components Workbench software.

## Six-channel Trimpot — 2080-TRIMPOT6

This trimpot plug-in offers an affordable method of adding six analog presets for speed, position and temperature control.

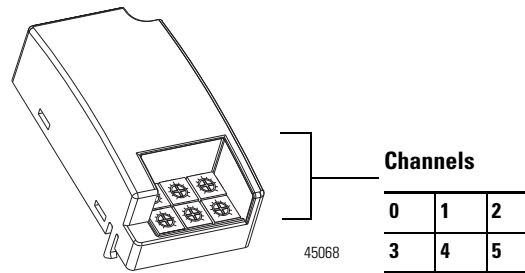

## High Speed Counter — 2080-MOT-HSC

This plug-in module provides enhanced high speed counter capabilities to the Micro800 controller. It supports the same functionalities of an embedded HSC on the Micro800 controllers but is enhanced to support up to 250 KHz 5V differential line driver for improved noise immunity and provides additional dedicated I/O.

For more information, see [High Speed Counter – 2080-MOT-HSC on page 25](#).

## Communication Plug-ins

### RS232/RS485 Isolated Serial Port — 2080-SERIALISOL

The 2080-SERIALISOL plug-in supports CIP Serial (RS-232 only), Modbus RTU (RS232 and RS485), and ASCII (RS232 and RS485<sup>(1)</sup>) protocols. Unlike the embedded Micro800 serial port, this port is electrically isolated, making it ideal for connecting to noisy devices, such as variable frequency and servo drives,

(1) RS-485 support is only available from Connected Components Workbench revision 6.

as well as for communications over long cable lengths. Depending on the application and baud rate setting, you can extend this length.

---

**IMPORTANT** 2080-SERIALISOL is suitable for communication over longer cable length of up to 1000 m using RS485, with up to 19200 bps baud rate.

The electrical characteristics of cable used and good wiring practices are very critical in achieving reliable communication performance over longer cable length. A shielded twisted pair RS485 22AWG cable (example: 3106A from Belden) is recommended. Terminate both ends of the cable with 120 ohm resistance.

---

## **DeviceNet Scanner — 2080-DNET20**

The Micro800 DeviceNet plug-in module serves as a scanner and client for explicit messaging to remote devices including I/O and drives, using a proven and well-accepted fieldbus/network. It also provides better performance than using serial and Ethernet (EtherNet/IP Class 3) communications.

For more information, see the [DeviceNet Plug-in – 2080-DNET20 on page 39](#).

**Notes:**



## Install and Wire Your Module

This chapter provides hardware features, installation, and wiring connection diagrams for all the Micro800 plug-in modules.

### Hardware Features

The plug-in modules, except for the 2080-MEMBAK-RTC, can be plugged into any plug-in slots on the Micro800 controllers.

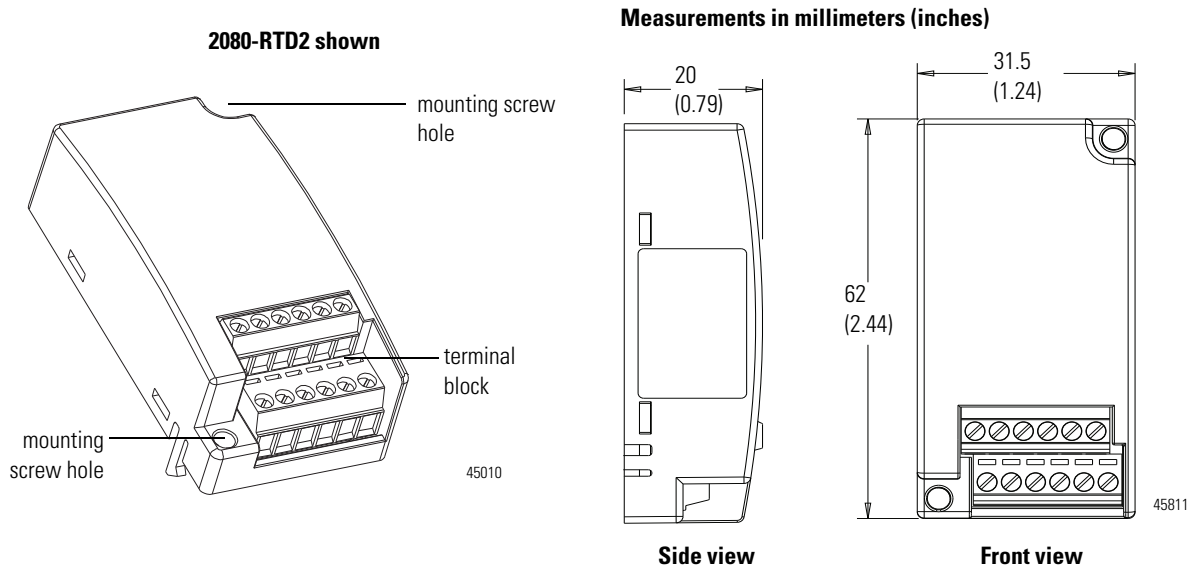

### Insert Module into Controller

Follow the instructions to insert and secure the plug-in module to the controller.

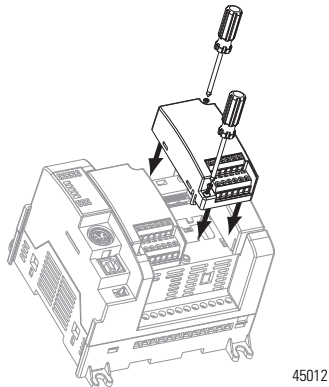

1. Position the plug-in module with the terminal block facing the front of the controller as shown.
2. Snap the module into the module bay.
3. Using a screwdriver, tighten the 10...12 mm (0.39...0.47 in.) M3 self tapping screw to torque specifications.  
See [Specifications on page 59](#) for torque specifications.

**IMPORTANT** Analog I/O performance depends on the application. For better noise immunity, cable length should ideally be less than 10 m because the plug-ins are non-isolated. For longer cable length requirements, use the 2085 expansion I/O modules instead.

## Wiring

The following plug-in modules have 12-pin female terminal blocks:

- 2080-IQ4,
- 2080-IQ4OB4, 2080-IQ4OV4
- 2080-OB4, 2080-OV4, 2080-OW4I
- 2080-IF2, 2080-IF4
- 2080-TC2, 2080-RTD2

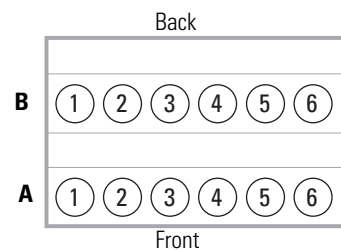

Twelve-pin Female Terminal Block

### Pin Designations for 12-Pin Female Terminal Block Modules

Pin	2080-IQ4	2080-IQ4OB4, 2080-IQ4OV4	2080-OB4, 2080-OV4	2080-OW4I	2080-IF2	2080-IF4	2080-TC2	2080-RTD2
A1	I-02	I-02	Not used	COM3	COM	COM	CH0+	CH0+
A2	I-03	I-03	Not used	O-3	Not used	VI-2	CH0-	CH0-
A3	COM	COM	-24V DC	Not used	Not used	CI-2	CJC+	CH0L (Sense)
A4	COM	-24V DC	-24V DC	Not used	COM	COM	Not used	Not used
A5	Not used	O-02	O-02	Not used	Not used	VI-3	Not used	Not used
A6	Not used	O-03	O-03	Not used	Not used	CI-3	Not used	Not used
B1	I-00	I-00	Not used	COM0	VI-0	VI-0	CH1+	CH1+
B2	I-01	I-01	Not used	O-0	CI-0	CI-0	CH1-	CH1-
B3	COM	COM	+24V DC	COM1	COM	COM	CJC-	CH1L (Sense)
B4	COM	+24V DC	+24V DC	O-1	VI-1	VI-1	Not used	Not used
B5	Not used	O-00	O-00	COM2	CI-1	CI-1	Not used	Not used
B6	Not used	O-01	O-01	O-2	COM	COM	Not used	Not used

The following plug-in modules have eight-pin female terminal blocks:

- 2080-OF2
- 2080-SERIALISOL
- 2080-MOT-HSC

**Pin Designations for 8-Pin Female Terminal Block Modules**

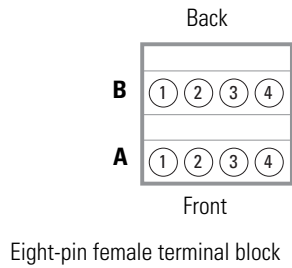

Pin	2080-OF2	2080-SERIALISOL	2080-MOT-HSC <sup>(1) (2)</sup>
<b>A1</b>	COM	RS485 B+	0-
<b>A2</b>	COM	GND	A-
<b>A3</b>	COM	RS232 RTS	B-
<b>A4</b>	COM	RS232 CTS	Z-
<b>B1</b>	VO-0	RS232 DCD	0+
<b>B2</b>	CO-0	RS232 RXD	A+
<b>B3</b>	VO-1	RS232 TXD	B+
<b>B4</b>	CO-1	RS485 A-	Z+

(1) **IMPORTANT:** Individually shielded, twisted-pair cable (or the type recommended by the encoder or sensor manufacturer) should be used for the 2080-MOT-HSC plug-in.

(2) Sinking Output/Sourcing Output wiring for the 2080-MOT-HSC plug-in is shown below.

**Sinking Output Wiring**

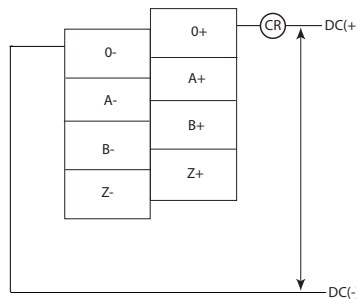

**Sourcing Output Wiring**

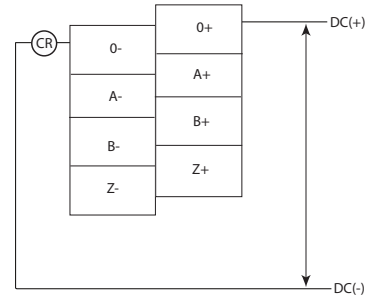

### Serial Port to Modem Cable Pinout

When connecting Micro800 to a modem using an RS-232 cable, the maximum that the cable length may be extended is 15.24 m (50 ft).

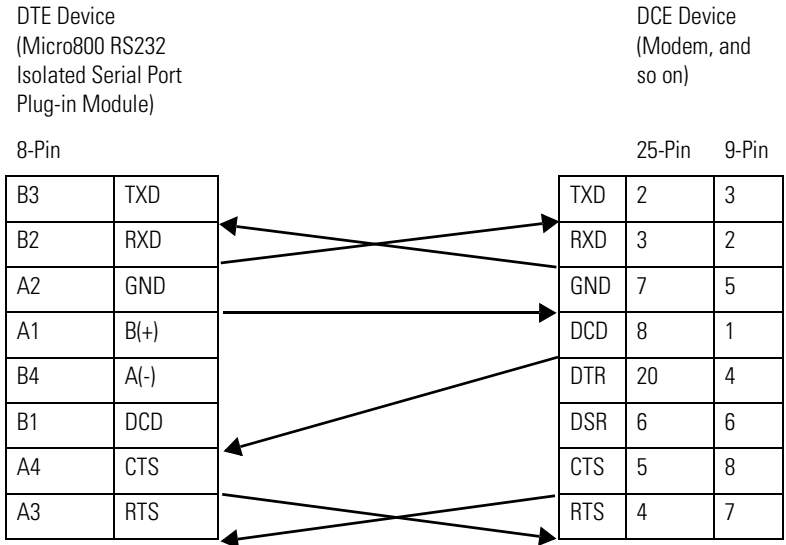

**ATTENTION:** Do not connect to pins A1 and B4 for RS-232 connections. This connection will cause damage to the RS-232/485 communication port.

### 2080-DNET20 – 6-pin Female Terminal Block

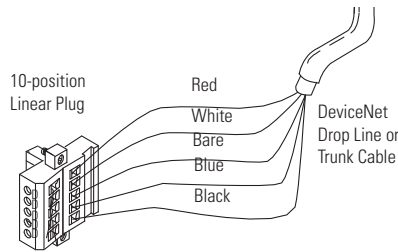
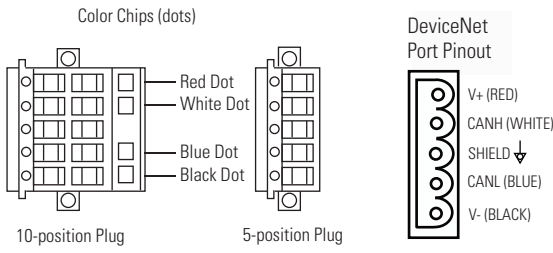

20474

### 2080-DNET20: Sample network wiring using KwikLink™ Lite Flat media

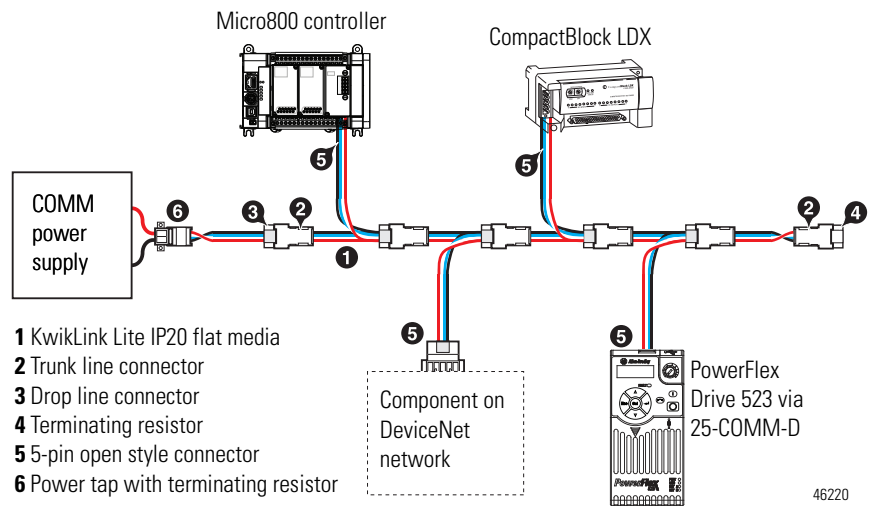

**IMPORTANT** Individually shielded, twisted-pair cable (or the type recommended by the encoder or sensor manufacturer) should be used for the 2080-MOT-HSC plug-in.



## Wiring Considerations and Applications for 2080-TC2

### Type of CJC Sensor

The CJC sensor is a non-polarized, passive negative temperature co-efficient thermistor (EPCOS B57869S0502F140). It is readily available in the market with most third party suppliers/vendors.

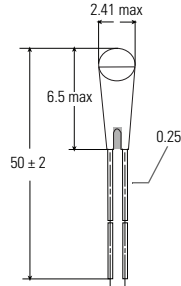



---

#### IMPORTANT CJC Channel Error

The CJC channel on 2080-TC2 has a worst-case error of  $\pm 1.2\text{ }^{\circ}\text{C}$  @  $25\text{ }^{\circ}\text{C}$ . This error does not include the manufacturer-specified sensor error  $\pm 0.2\text{ }^{\circ}\text{C}$  @  $25\text{ }^{\circ}\text{C}$ .

---

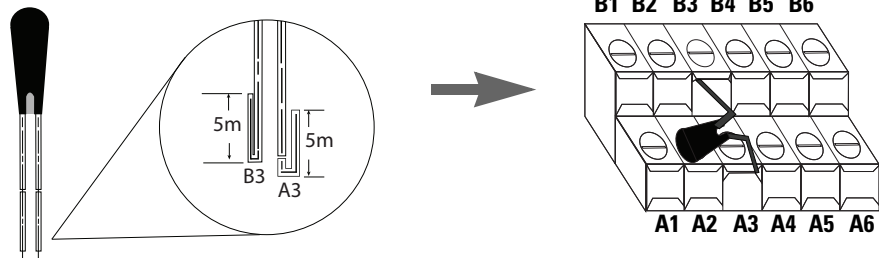
### Wire the CJC Thermistor on the 2080-TC2 Module



1. Connect the thermocouples to channel 0 and 1, respectively. Then, connect and screw the thermistor to terminals A3 and B3.
2. Once fitted, bend the black bead of the thermistor such that it makes contact with the A2 screw securely.

The position for the thermistor, as illustrated, helps to compensate for thermoelectric voltages developed at screw junction equally for thermocouples connected to channels 0 and 1. If the bead is not in proper contact with the screw, there will be deviation in readings due to inadequate isothermal compensation.

#### *Wire the Thermocouple Module and Thermocouple Sensor in the Field*

Connect the thermocouple sensors directly to the module terminals.

**Direct sensor wiring**

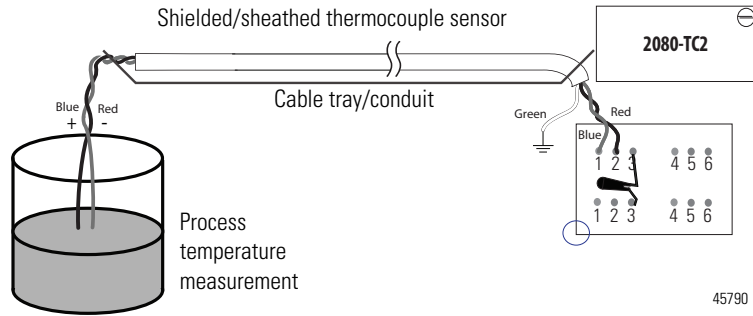

**ATTENTION:** Direct wiring is the preferred method of wiring for thermocouples.

**Wiring Considerations and Applications for 2080-RTD2**

**Two-wire and Three-Wire Wiring**

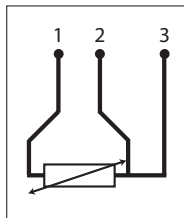

3 Wire

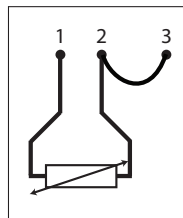

2 Wire

45772

**Wire the RTD Sensors**

In an RTD sensor, the sensing element is always connected between two wires of different colors. Wires of the same color are shorted and form the compensation leads. Measuring resistance between these wires confirms the position of sensing element and compensation elements. Compensation elements will always show 0 ohms.

### Wire the Sensors

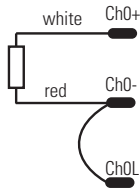

2-wire sensor connection

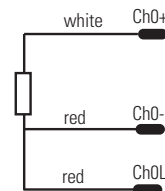

3-wire single sensor connection

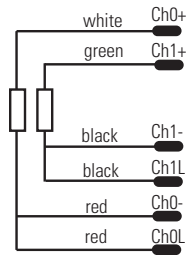

3-wire dual sensor connection

45778

**NOTE:** This illustration provides for channel 0 only for 2- and 3-wire single sensor connections. The wire colors illustrate a particular type of RTD sensor available in market.

For better accuracy in noisy industrial environments, 3- or 4-wire RTD sensors are mostly used. While using these sensors, the resistance added by lead lengths is compensated by an additional third wire in case of 3-wire RTD and two additional wires, in bridge configuration, in case of 4-wire RTD. For 2-wire RTD sensor in this module, this lead compensation is provided by using an external 50 mm 22 AWG shorting wire between terminals A2, A3 and B2, B3 for channel 0 and 1, respectively. Shielded twisted pair cables are to be utilized for remote use of these sensors with cable shield grounded at controller end.

### Wire the RTD Module and RTD Sensor in the Field

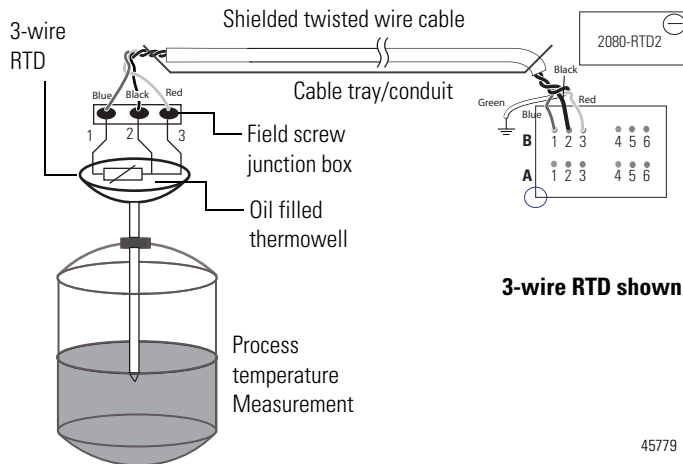

45779

The RTD sensing element should always be connected between terminals B1(+) and B2(-) for channel 1, and A1(+) and A2(-) for channel 0 in the module. Terminals B3 and A3 should always be shorted to B2 and A2, respectively, to complete the constant current loop. Mismatch in wiring can cause erroneous, over, or underrange readings.

---

**IMPORTANT** Cabling used with the 2080-TC2/RTD2 modules have to be shielded twisted cores with the shield wire shorted to chassis ground at controller end. It is advisable to use 22 AWG wires to connect the sensors to the module. Use sensors dipped in oil-filled thermowells for stable and uniform readings. Recommended cable type: Alpha wire P/N 5471C. Performance is dependent on the application. For better noise immunity, cable length should ideally be less than 10 m because the plug-ins are non-isolated. For longer cable length requirements, use the 2085 expansion I/O modules instead.

---

## Wiring Applications for 2080-MOT-HSC

The following diagrams show wiring applications for the 2080-MOT-HSC plug-in with Kinetix® Servo drives.

### Kinetix 3 in feedback configuration to 2080-MOT-HSC

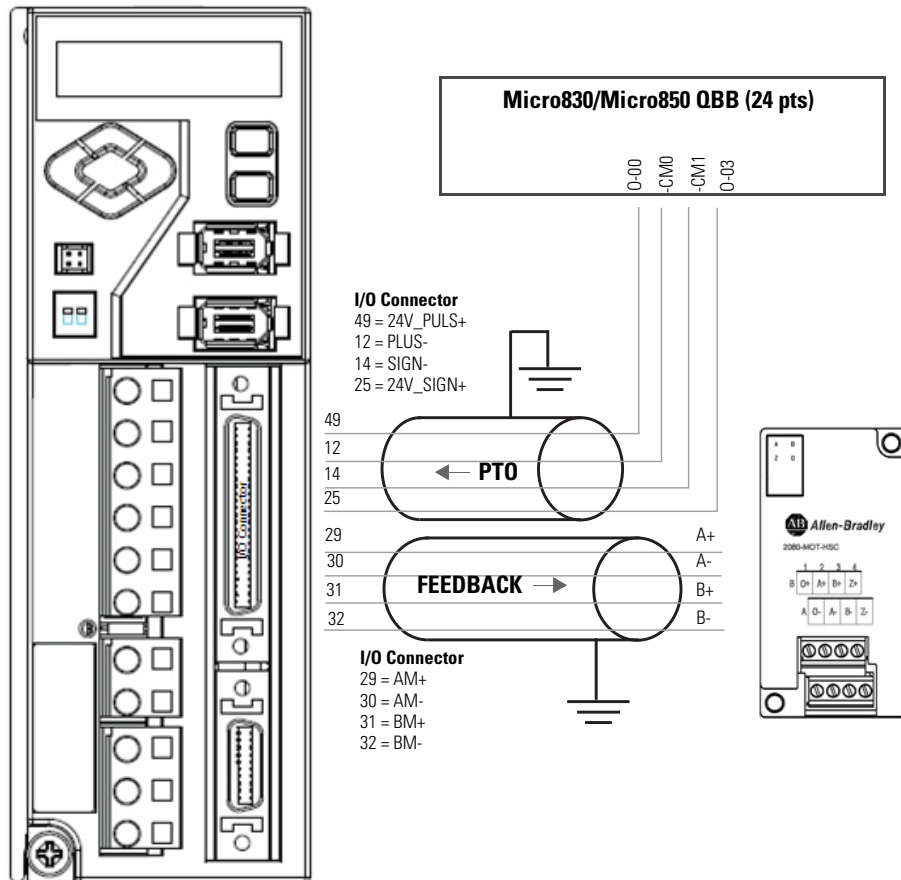

### Kinetix 300 in feedback configuration to 2080-MOT-HSC





**Notes:**

---

## **Non-isolated Thermocouple and RTD Plug-in Modules – 2080-TC2 and 2080-RTD2**

The Thermocouple (2080-TC2) and RTD (2080-RTD2) plug-in modules allow for temperature measure and control when used with PID.

This plug-in can be used in any slot of your Micro830/Micro850 controller. Removal and Insertion Under Power (RIUP) is not supported.

### **Thermocouple Module**

The 2080-TC2 two-channel plug-in module supports thermocouple measurement. It digitally converts and transmits temperature data from any combination of up to eight types of thermocouple sensors. Each input channel is individually configurable through the Connected Components Workbench software for a specific sensor, filter frequency.

### **Thermocouple Sensor Types and Ranges**

The module supports B, E, J, K, N, R, S, T types of thermocouple sensors. The module channels are referred to as Channel 0, Channel 1, and CJC, respectively. The cold junction compensation is provided by an external NTC thermistor, which comes with the module. The thermistor has to be fitted to the screw terminals A3 and B3 of the module. This CJC is common to channel 0 and 1 thermocouple sensors and provides open-circuit, overrange and underrange detection and indication.

#### *Overrange and Underrange Conditions*

If the channel temperature input is below the minimum value of its normal temperature range for the represented sensor, the module reports an underrange error through the Connected Components Workbench global variables. If the channel reads above the maximum value of its normal temperature range for the represented sensor, an over-range error is flagged.

The table below defines thermocouple types and their associated full-scale temperature ranges.

**Thermocouple Sensor Types and Temperature Ranges**

Thermocouple Type	Temperature Range °C (°F)		Accuracy °C (°F)		ADC Update Rate in Hz (Accuracy °C)
	Min	Max	±1.0 °C	±3.0 °C	
<b>B</b>	40 (104)	1820 (3308)	90...1700 (194...3092)	< 90 (194) > 1700 (3092)	4.17, 6.25, 10, 16.7 (±1.0) 19.6, 33, 50, 62, 123, 242, 470 (±3.0)
<b>E</b>	-270 (-454)	1000 (1832)	-200...930 (-328...1706)	< -200 (-328) > 930 (1706)	
<b>J</b>	-210 (-346)	1200 (2192)	-130...1100 (-202...2012)	< -130 (-202) > 1100 (2012)	
<b>K</b>	-270 (-454)	1370 (2498)	-200...1300 (-328...2372)	< -200 (-328) > 1300 (2372)	
<b>N</b>	-270 (-454)	1300 (2372)	-200...1200 (-328...2192)	< -200 (-328) > 1200 (2192)	
<b>R</b>	-50 (-58)	1760 (3200)	40...1640 (104...2984)	< 40 (104) > 1640 (2984)	
<b>S</b>	-50 (-58)	1760 (3200)	40...1640 (104...2984)	< 40 (104) > 1640 (2984)	
<b>T</b>	-270 (-454)	400 (752)	-220...340 (-364...644)	< -220 (-364) > 340 (644)	

To configure Thermocouple type and update rate in Connected Components Workbench software, refer to the section [Quickstart on page 79](#).

**RTD Module**

The 2080-RTD2 module supports RTD measurement applications that support up to two channels. The module digitally converts analog data and transmits the converted data in its image table.

The module supports connections from any combination of up to eleven types of RTD sensors. Each channel is individually configurable through the Connected Components Workbench software. When configured for RTD inputs, the module can convert the RTD readings into temperature data. Refer to [Temperature Conversion – Data to Degree Celsius \(°C\) on page 23](#), for converting temperature data to actual temperature degree.

**RTD Sensor Types and Ranges**

Each channel provides open-circuit (all wires), short-circuit (excitation and return wires only), and over- and under-range detection and indication. The 2080-RTD2 module supports 11 types of RTD sensors:

Pt100 385	PT1000 385	PT500 392	Ni120 672
PT200 385	PT100 392	PT1000 392	NiFe604 518
PT500 385	PT200 392	Cu10 427	

It supports two- and three-wire type of RTD sensor wiring.

### RTD Compatibility

An RTD consists of a temperature-sensing element connected by two, three, or four wires that provide resistance input to the module. The following table lists the RTD types that you can use with the module, including their temperature range, accuracy, and ADC update rate.

### Overrange and Underrange Conditions

If the channel temperature input is below the minimum value of its normal temperature range for the represented sensor, the module reports an underrange error through the Connected Components Workbench global variables. If the channel temperature input is above the maximum value of its normal temperature range for the represented sensor, an over-range error is flagged.

### RTD Sensor Types and Temperature Ranges

RTD Type	Temperature Range ° C (°F)		Accuracy ° C (°F)		ADC Update Rate in Hz (Accuracy ° C)
	Min	Max	±1.0 °C	±3.0 °C	
<b>PT100 385</b>	-200 (-328)	660 (1220)	-150...590 (-238...1094)	< -150 (-238) > 590 (1094)	<b>3-wire others</b> 4.17, 6.25, 10, 16.7, 19.6, 33, 50 (±1.0) 62, 123, 242, 470 (±3.0)
<b>PT200 385</b>	-200 (-328)	630 (1166)	-150...570 (-238...1058)	< -150 (-238) > 570 (1058)	
<b>PT500 385</b>	-200 (-328)	630 (1166)	-150...580 (-238...1076)	< -150 (-238) > 580 (1076)	<b>2- and 3-wire Cu10<sup>(1)</sup></b> 4.17, 6.25, 10, 16.7 (>±1.0 < ±3.0) 19.6, 33, 50, 62, 123, 242, 470 (> ±3.0)
<b>PT1000 385</b>	-200 (-328)	630 (1166)	-150...570 (-238...1058)	< -150 (-238) > 570 (1058)	
<b>PT100 392</b>	-200 (-328)	660 (1220)	-150...590 (-238...1094)	< -150 (-238) > 590 (1094)	<b>2-wire others</b> 4.17, 6.25, 10, 16.7 (±1.0) 19.6, 33, 50, 62, 123, 242, 470 (±3.0)
<b>PT200 392</b>	-200 (-328)	630 (1166)	-150...570 (-238...1058)	< -150 (-238) > 570 (1058)	
<b>PT500 392</b>	-200 (-328)	630 (1166)	-150...580 (-238...1076)	< -150 (-238) > 580 (1076)	
<b>PT1000 392</b>	-50 (-58)	500 (932)	-20...450 (-4...842)	< -20 (-4) > 450 (842)	
<b>Cu10 427<sup>(1)</sup></b>	-100 (-148)	260 (500)		< -70 (-94) > 220 (428)	
<b>Ni120 672</b>	-80 (-112)	260 (500)	-50...220 (-58...428)	< -50 (-58) > 220 (428)	
<b>NiFe604 518</b>	-200 (-328)	200 (392)	-170...170 (-274...338)	< -170 (-274) > 170 (338)	

(1) For Cu10 427, accuracy range is within  $\pm 1.0 < \pm 3.0$  for  $-70...220$  °C ( $-94...428$  °F). Above this temperature range, it is  $> \pm 3.0$  °C as shown in the table.

# Connected Components Workbench Global Variables Data Maps

The following bit/words describe the information read from the Thermocouple and RTD plug-in modules in the Connected Components Workbench Global Variables.

Mapping Table

Word Offset	Bit															
	15	14	13	12	11	10	09	08	07	06	05	04	03	02	01	00
00 (example: _IO_P1_AI_00)	Channel 0 Temperature Data															
01 (example: _IO_P1_AI_01)	Channel 1 Temperature Data															
02 (example: _IO_P1_AI_02)	Channel 0 Information															
	UKT	UKR	Reserved			Reserved		OR	UR	OC	DI	CC	Reserved			
03 (example: _IO_P1_AI_03)	Channel 1 Information															
	UKT	UKR	Reserved			Reserved		OR	UR	OC	DI	CC	Reserved			
04 (example: _IO_P1_AI_04)	System Information															
	Reserved				SOR	SUR	COC	CE	Reserved							

### Bit Definitions

Bit Name	Description
Channel Temperature Data	The temperature count mapped from temperature Celsius degree with one decimal. Please check the section, <a href="#">Temperature Conversion – Data to Degree Celsius (°C) on page 23</a> , for the mapping formula.
UKT (Unknown Type)	Bit set to report an unknown sensor type error in configuration.
UKR (Unknown Rate)	Bit set to report an unknown update rate error in configuration.
OR (Overrange)	Bit set to indicate overrange on channel input. The Channel Temperature Data shows maximum temperature count for individual type of sensor used and the value does not change until overrange error is clear.
UR (Underrange)	Bit set to indicate the channel input underrange happens. The Channel Temperature Data will show minimum temperature count for individual type of sensor used and the value does not change until underrange error is clear.
OC (Open Circuit)	Bit set to indicate open-circuit on the channel input sensor.
DI (Data Illegal)	The data in the channel data field is illegal and cannot be used by user. This bit is set when temperature data is not ready for use.
CC (Code Calibrated)	Bit set indicates temperature data is calibrated by the system calibration coefficient.
SOR (System Overrange)	Bit set to indicate system overrange error with environment temperature over 70 °C.
SUR (System Underrange)	Bit set to indicate system underrange error with environment temperature under -20 °C.
COC (CJC open-circuit)	Bit set to indicate CJC sensor not connected for thermocouple module, open circuit. This bit is for thermocouple module only.
CE (Calibration Error)	Bit set indicates that the module is not accurate. This bit is set to 0 by default and should remain as 0. Contact Technical Support when the value is otherwise.

## Temperature Conversion – Data to Degree Celsius (°C)

To keep the precision of temperature value from the Thermocouple and RTD plug-in modules, there is a general data mapping conversion in the firmware before the actual temperature is sent to the Connected Components Workbench software.

The following equation shows how the Connected Components Workbench software data count is mapped from temperature Celsius degree by the firmware:

$$\text{Connected Components Workbench software Data Count} = (\text{Temp } (^\circ\text{C}) + 270.0) * 10;$$

---

**IMPORTANT**

This conversion formula applies to all types of Thermocouple and RTD sensors.

---

This equation illustrates how the Connected Components Workbench data count does not use full range of 0...65535 of data word.

*Derive Actual Temperature °C From Connected Components Workbench Data Count:*

The following formula shows how to derive temperature Celsius degree from temperature data word in the Connected Components Workbench software:

$$\text{Temp } (^\circ\text{C}) = (\text{Data} - 2700) / 10;$$

Examples:

$$1234 \rightarrow (1234 - 2700) / 10 \rightarrow -146.6^\circ\text{C}$$

$$8000 \rightarrow (8000 - 2700) / 10 \rightarrow 530.0^\circ\text{C}$$

---

**IMPORTANT**

Underrange, overrange error reporting checking is **not** based on Connected Components Workbench temperature data count, but the actual temperature (°C) or the voltage going into the plug-in module.

---

**Notes:**



## High Speed Counter – 2080-MOT-HSC

### Overview

The 2080-MOT-HSC plug-in module provides enhanced high speed counter capabilities to the Micro800 controller. It supports the same functionalities of an embedded high-speed counter on the Micro800 controllers but is enhanced to support up to 250 KHz 5V differential line driver for improved noise immunity and provides additional dedicated I/O.

The 2080-MOT-HSC module supports most commercial encoders (5V differential or 24V single-ended).

---

#### IMPORTANT

To configure the plug-in module, you need to download and use the HSC UDFBs from the Sample Code Library:

<http://www.rockwellautomation.com/go/scmicro800>

From Connected Components Workbench Release 7.0 onwards, the sample code is included in the installation and is located in the folder: `\documents\public documents\ccw\samples\rockwell automation\udfb`

See [Quickstart Projects for 2080-MOT-HSC Plug-in on page 93](#) for step-by-step instructions on how to use the plug-in with a sample project.

---

#### IMPORTANT

From Connected Components Workbench Release 8.0 onwards, support has been added for a HSC Feedback Axis which uses the same instructions as the PTO Motion Axis. UDFBs are still supported (you can use either one but you cannot select both for the same plug-in).

---

### Counter Specifications

Filter and decode inputs: 3 input points A, B, Z

These input points may come from different types and configurations of sensors. The user must configure the module to respond to the type of sensor connected to the module as described below. This can be configured in the 2080-MOT-HSC UDFB. From Connected Components Workbench Release 8.0 onwards, if you have configured the plug-in for Feedback Axis, you can also edit the input filter values in the plug-in configuration module properties.

Nominal Filter Settings	Maximum Guaranteed Block Pulse Width	Minimum Guaranteed Pass Pulse Width
No Filter – Default	–	–
250 kHz (DC 2 μs)	512 kHz (DC 0.95 μs)	265kHz (DC 1.9 μs)
200 kHz (DC 2.5 μs)	333 kHz (DC 1.5 μs)	201 kHz (DC 2.48 μs)

Nominal Filter Settings	Maximum Guaranteed Block Pulse Width	Minimum Guaranteed Pass Pulse Width
80 kHz (DC 6.25 μs)	128 kHz (DC 3.9 μs)	86.7 kHz (DC 5.8 μs)
40 kHz (DC 12.5 μs)	62.8 kHz (DC 8.0 μs)	42.5 kHz (DC 11.6 μs)
13.3 kHz (DC 35 μs)	20.8 kHz (DC 24.1 μs)	14.1 kHz (DC 35.5 μs)
10 kHz (DC 50 μs)	15.7 kHz (DC 32.1 μs)	10.5 kHz (DC 47.2 μs)
4 kHz (DC 125 μs)	6.3 kHz (DC 80.3 μs)	4.2 kHz (DC 119 μs)
2 kHz (DC 250 μs)	3.2 kHz (DC 161 μs)	2.1 kHz (DC 237 μs)
1 kHz (DC 0.5 ms)	1.6 kHz (DC 0.33 ms)	1.0 kHz (DC 0.48 ms)
500 Hz (DC 1 ms)	778 Hz (DC 0.65 ms)	527 Hz (DC 0.95 ms)
250 Hz (DC 2 ms)	389 Hz (DC 1.3 ms)	263 Hz (DC 1.9 ms)
125 Hz (DC 4 ms)	195 Hz (DC 2.6 ms)	131 Hz (DC 3.79 ms)
62.5 Hz (DC 8 ms)	97.3 Hz (DC 5.2 ms)	65.9 Hz (DC 7.6 ms)
31.25 Hz (DC 16 ms)	38.8 Hz (DC 10.3 ms)	32.9 Hz (DC 15.2 ms)

**IMPORTANT** For low frequency pulses, filter times should be set appropriately to avoid extra pulses from a noisy environment. For high frequency pulses, shielded cable must always be used.

**IMPORTANT** When the controller is power cycled, the value of the counters are reset to zero.

The counters are not reset to zero for program download. For example, if using the feedback axis, use the MC\_ResetPosition function block to reset the position to zero.

### Number of Counters: 1 to 2

The module may be configured, using HSC\_Mode, to use the inputs as 1 or 2 counters.

1 counter: A, B, Z = Counter 0

2 counters: A, Z = Counter0; B = Counter 1

#### Counter Pin Usage

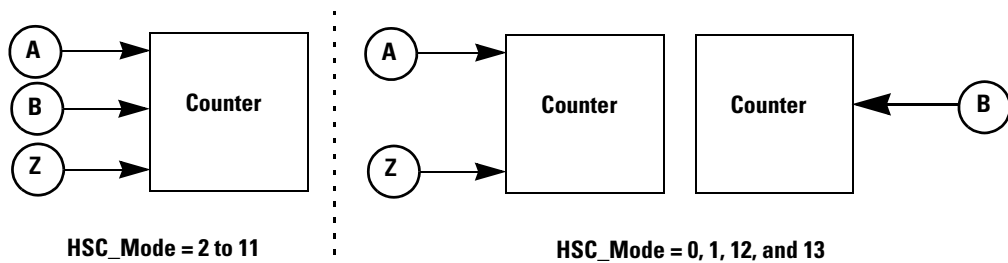

### Input Operational Modes

Mode	Description
0	Up Counter – The accumulator is immediately cleared (0) when it reaches the high preset. A low preset cannot be defined in this mode.
1	Up Counter with external reset and hold – The accumulator is immediately cleared (0) when it reaches the high preset. A low preset cannot be defined in this mode.
2	Counter with external direction.
3	Counter with external direction, reset, and hold.
4	Two input counter (up and down).
5	Two input counter (up and down) with external reset and hold.
6	Quadrature counter (phased inputs A and B).
7	Quadrature counter (phased inputs A and B) with external reset and hold.
8	Quadrature X4 counter (phased inputs A and B).
9	Quadrature X4 counter (phased inputs A and B) with external reset and hold.
10	Quadrature X2 counter (phased inputs A and B).
11	Quadrature X2 counter (phased inputs A and B) with external reset and hold.
12	Down Counter.
13	Down Counter with external reset and hold.

### Up Counter

Pulses on A will cause the up counter (Counter 0). Also Pulses on B will cause the up counter (Counter 1).

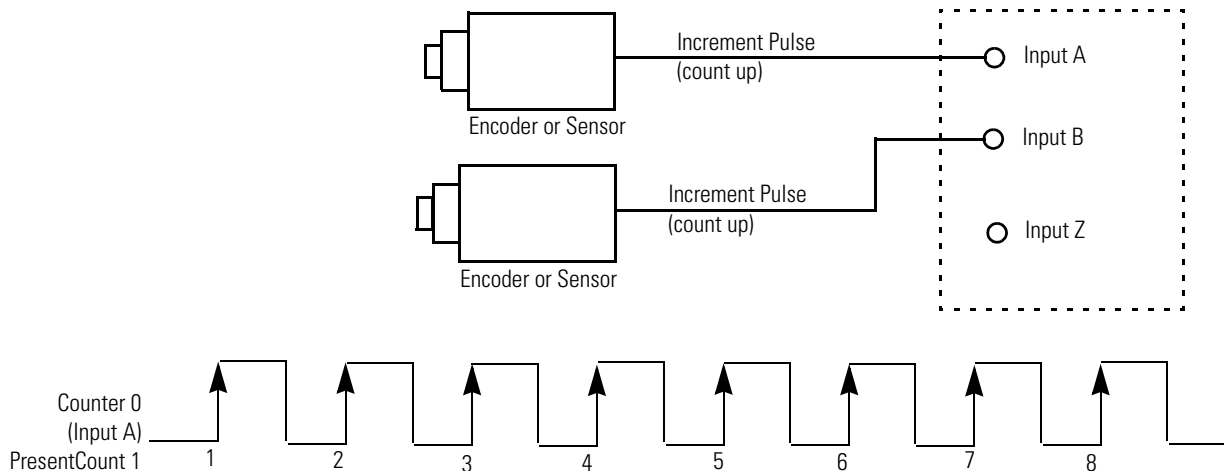

## Counter with External Direction

Pulses on A cause the counter to increment when B is low and decrement when B is high. When B is open or undriven, the counter will increment. See [Pulse External Direction Counting on page 28](#).

### Pulse External Direction Counting

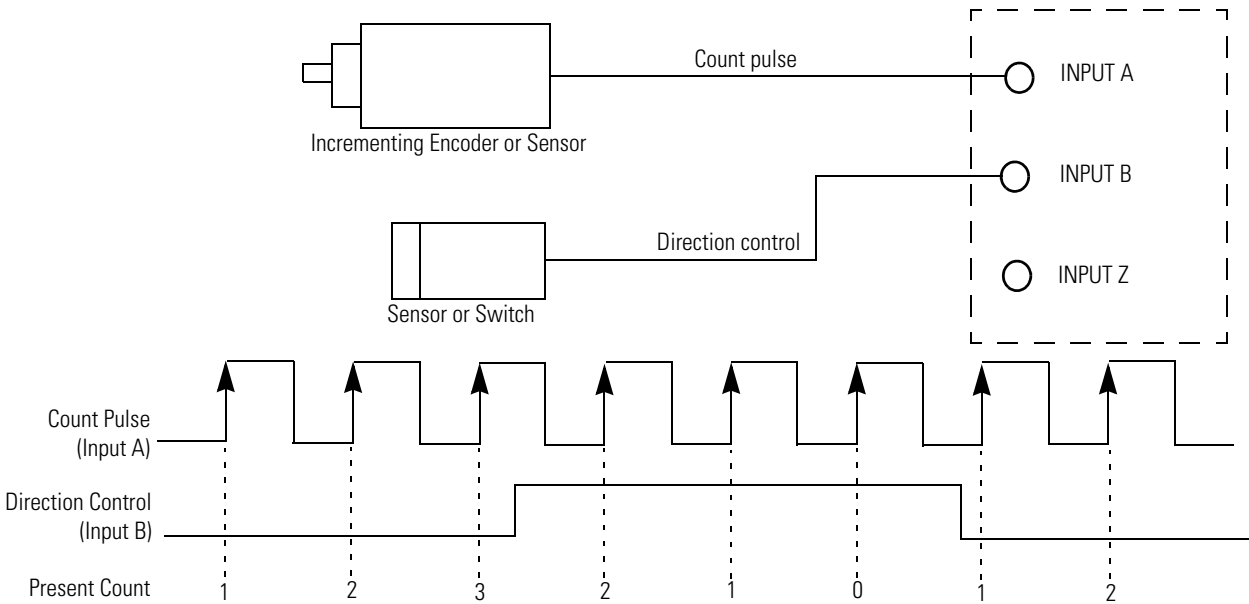

A	B	Change in Count Value
↑	0 (Open or No Connection)	+1
↑	1	-1
1	X (don't care)	0
0	X (don't care)	0

### Two input counter (Up/Down Pulses)

Pulses on A causes the counter to increment. Pulses on B causes the counter to decrement. Pulses may occur at any time. Note that pulses can occur very closely (that is, much faster than plug-in scan time) that the plug-in never notices the change in count. In such cases, both counts may be ignored (the net change being zero anyway). In no case shall a pulse be lost. See the following diagram.

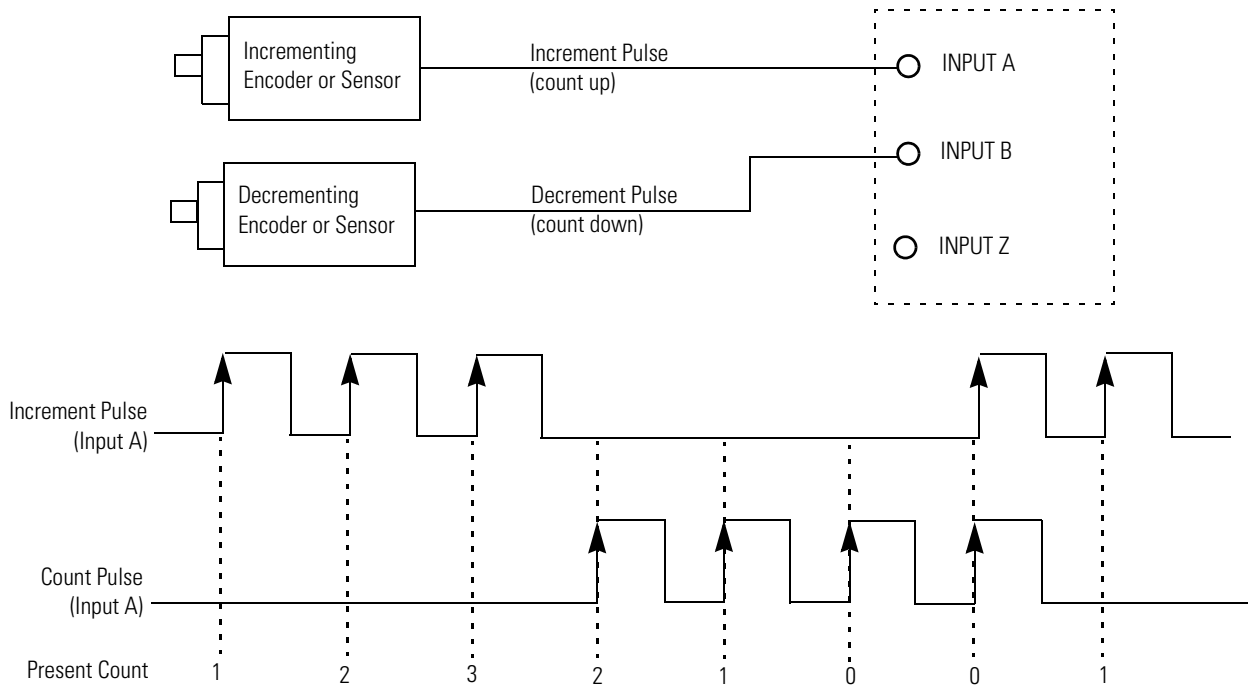

**Up/Down Counting**

A	B	Change in Count Value
↑	0 or 1	+1
0 or 1	↑	-1
↑	↑	0
0	0	0

*Quadrature Counter (X1)*

The module is compatible with 2 and 3 signal quadrature, or incremental encoders. The A and B signals are offset by 90 degrees and encode the direction of the rotation. The third signal, Z, occurs once per revolution and is often used as a home reference. The module’s use of this signal is discussed below in the Z input section.

### Quadrature Counting

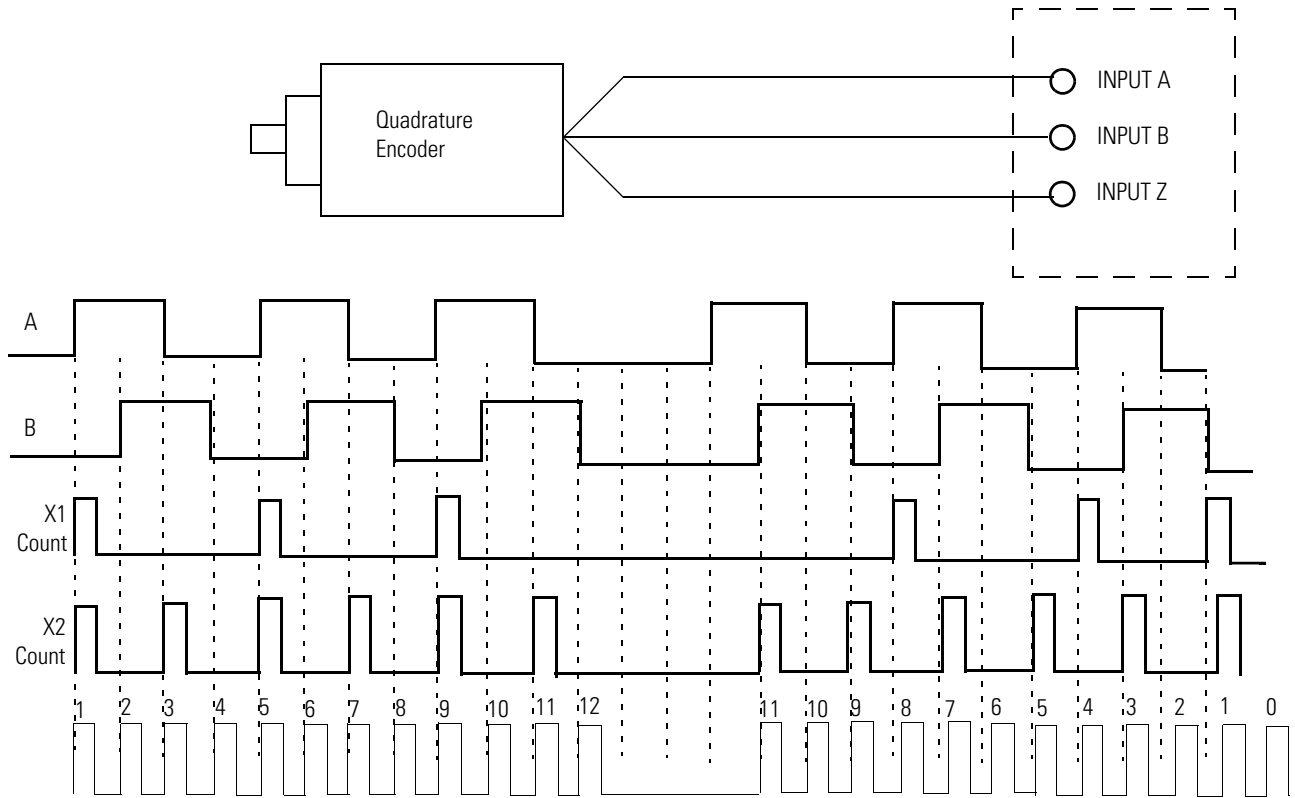

#### Quadrature X4 Counter

Counter shall increment or decrement on each edge of the A and B pulses when the signal is in the positive or negative direction respectively. See previous illustration.

#### Quadrature X2 Counter

The counter increments or decrements on each edge of the A pulse when the signal is in the positive or negative direction respectively. See previous illustration.

#### Down Counter

Pulses on A will cause the down counter (Counter 0). Also pulses on B will cause the down counter (Counter 1).

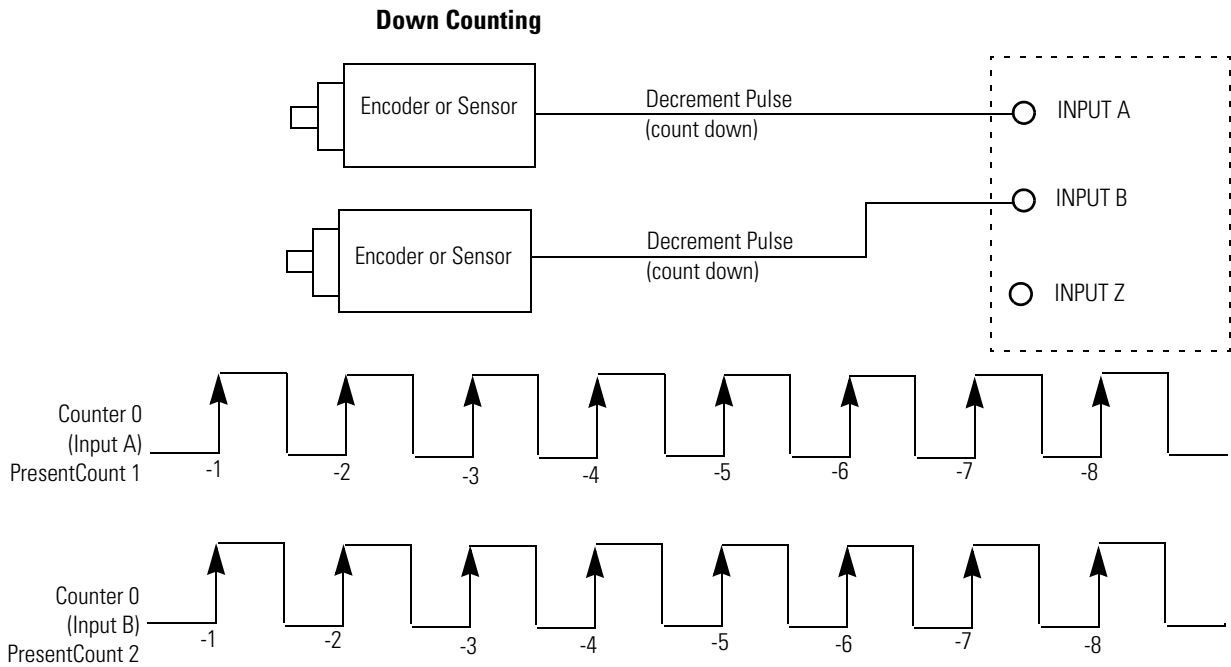

### Z Input (Gate) Function/Touch Probe

This signal functionality supports:

- **Touch Probe** the present count value on the rising edge of IntZ\_n to the HSC\_Touch Probe term in the backplane input file.
- **Hold** the counter at its present count value while IntZ\_n = 1,
- **Reset** the present count value on rising edge of IntZ\_n.

---

**IMPORTANT** If the module gets two or more Z pulses during a single plug-in scan the HSC\_TouchProbe will be overwritten with the last stored value. There will be no indication that more than one store has occurred.

---

### Ring or Linear Counter

The counter may be configured with the RingOrLinearCnt\_n control bit to rollover at its limits (ring counter) or to stop counting and set a flag (linear counter).

**0: ring counter.** When the counter is a ring counter and the present count value is equal to MaxCountValue\_n, the next input count in the up direction will cause the PresentCount\_n to become the MinCountValue\_n. This action is known as rollover. And the CountOverflow\_n flag will be set to indicate that a rollover has happened. It is reset using the ResetCountOverflow bit.

Conversely, when the PresentCount\_n is equal to MinCountValue\_n the next input count in the down direction will cause the PresentCount\_n to become the MaxCountValue\_n. This action is known as rollunder. The CountUnderflow\_n

flag will be set to indicate that a rollover has occurred. It is reset using the ResetCountUnderflow\_n bit.

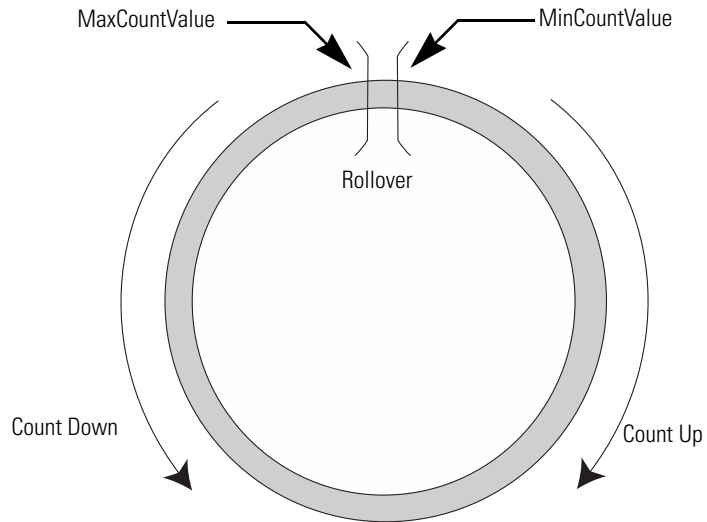

**1: linear counter.** When the counter is a linear counter and the present count value is equal to MaxCountValue\_n the next input count in the up direction will activate the CountOverflow\_n bit and also the PresentCount\_n will remain at the MaxCountValue\_n. CountOverflow\_n is reset using the ResetCountOverflow\_n bit.

Conversely, when the PresentCount\_n is equal to MinCountValue\_n the next input count in the down direction will activate the CountUnderflow\_n bit and the PresentCount\_n will remain at MinCountValue\_n. CountUnderflow\_n is reset using the ResetCountUnderflow\_n bit.

---

**IMPORTANT** The counts in overflow and underflow will not be accumulated at all. That is, even if 1000 pulses are applied while in overflow, the first pulse with the opposite direction (down in this case) will cause the counter to be decremented by 1. (The CountOverflow\_n bit is only reset using the ResetCountUnderflow\_n bit.)

---



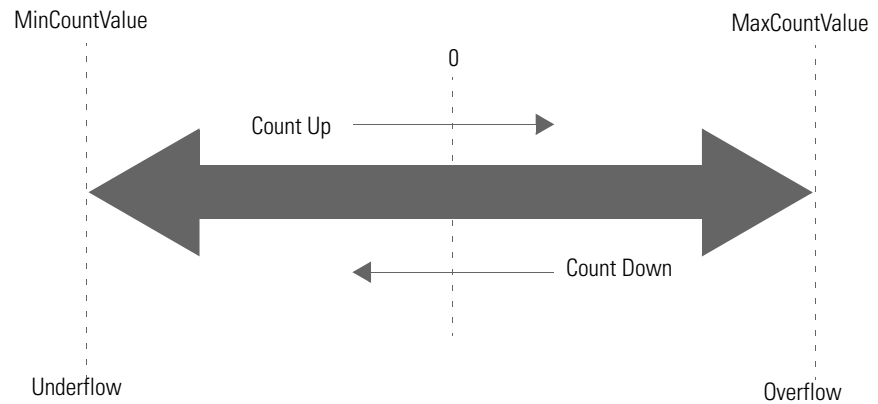

### *Enabling and Disabling a Counter using the HSC\_EN bit*

Disabling the counter does not inhibit any HSC\_ACC\_Bn loading functions (preset or direct write) or any Z function.

The module continuously calculates rates for each of the counters regardless of input operational mode.

### *Timer*

For the first two counters, a timer is used to measure the time between two successive pulses. This value is reported to the backplane as HSC\_PULSE\_WIDTH\_Bn.

## **Understanding Rates**

There are different applications which require rate information but there is no one perfect method for all. Generally, the user must weigh rate accuracy with the need for new information quickly.

Broadly, there are two different ways to calculate rates and optimize accuracy and speed of the rate of calculation:

- Per Pulse  
 $1/\text{HSC\_PULSE\_WIDTH\_B}$  (supported through 2080-MOT-HSC plug-in)  
HSC\_PULSE\_WIDTH\_Bn is reported to the user in the input array
- Cyclic  
Number of Pulses/User Defined Time Interval (supported through Connected Components Workbench)  
PresentRate\_n is reported to the user in the input array.

*Per Pulse*

The Per Pulse rate method can be very accurate if the time between pulses is large compared to the timer clock (1 μs for 2080-MOT-HSC). A timer is used to measure the time between the two successive pulses. This value is reported to the backplane as HSC\_PULSE\_WIDTH\_Bn after each pulse. The user may invert this value to derive a rate.

$$\text{Per Pulse rate} = 1 / \text{HSC\_PULSE\_WIDTH\_B}$$

However, when the time between pulses shrinks, two factors can distort the Per Pulse calculation of rate values:

- The time between pulses is closer to measuring the clock’s frequency, making the granularity of the time increments have a greater effect on rate inaccuracy.
- Also, the rate may be calculated many times over during the course of one backplane scan time. This means that the rate data is obtained at a backplane scan is only that of the very last pair of pulses and disregards the other rate calculations that have happened during that interval. This is especially problematic if the pulses during the update time are unevenly spaced, the reported rate could be based entirely on two pulses which are extremely close together (a very high rate) but a third pulse was separated by a greater time (low rate).

You must understand these limitations when using HSC\_PULSE\_WIDTH\_Bn to derive a rate.

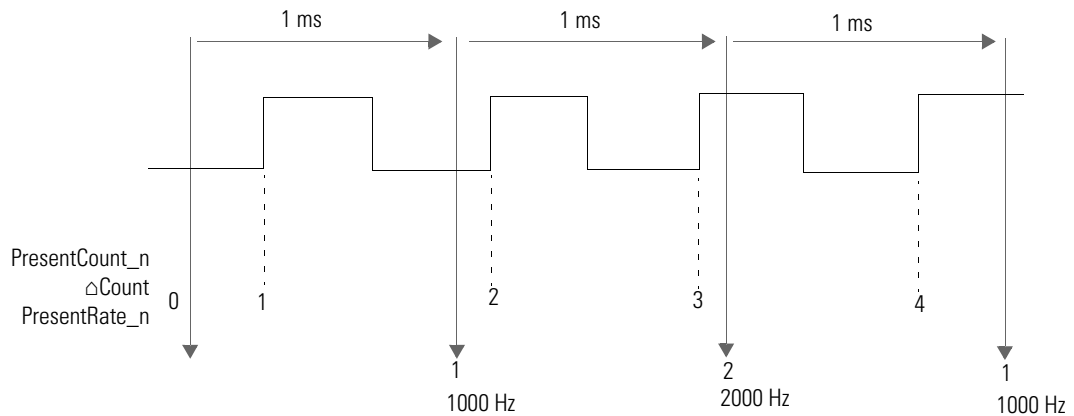

**Per Pulse Errors<sup>(1)</sup>**

Real pulses (note 1.9999 can be rounded to 2)	Pulses reported by module	Real Frequency	Reported Frequency	% Error
2	1	500 kHz	1 MHz	100%
9	10	111 kHz	100 kHz	11.1%
101	100	9.901 kHz	10.000 kHz	1.00%

**Per Pulse Errors<sup>(1)</sup>**

Real pulses (note 1.9999 can be rounded to 2)	Pulses reported by module	Real Frequency	Reported Frequency	% Error
1001	1000	999 Hz	1000 Hz	0.10%
9,999	10,000	100.01 Hz	100.00 Hz	0.010%
99,999	100,000	10.00010 Hz	10.00000 Hz	0.001%

(1) This table does not represent accuracy per pulse but repeatability. This repeatability can be applied in No Filter setting.

**Maximum Cyclic Rate Errors**

Update Time Value Scalar	Frequency				
	100 Hz	1 kHz	10 kHz	100 kHz	1 MHz
1	NA	NA	20.02%	20.02%	0.210%
10	NA	20.11%	2.020%	0.210%	0.030%
100	20.01%	2.110%	0.220%	0.031%	0.012%
1000	3.010%	0.310%	0.040%	0.013%	0.010%
10,000	1.210%	0.130%	0.022%	0.011%	0.010%

**IMPORTANT** For low frequency pulses, filter times should be set appropriately to avoid extra pulses from a noisy environment. For high frequency pulses, shielded cable must always be used.

**User Defined Function  
Blocks**

**RA\_HSCPlugin**

The purpose of this UDFB is to get high speed counter accumulator value and current pulse frequency.

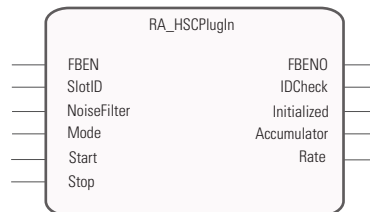

**RA\_HSCPlugIn: Input and Output Parameters**

Parameter	Type	Data Type	Description
FBEN	INPUT	BOOL	Function block Enable input
SlotID	INPUT	UINT	Plug-in slot number. Slot ID = 1...5 (starting with the far left slot 1.)
NoiseFilter	INPUT	USINT	00: No filter 01: 250 kHz 02: 200 kHz 03: 80 kHz 04: 40 kHz 05: 13.3 kHz 06: 10 kHz 07: 4 kHz 08: 2 kHz 09: 1 kHz 10: 500 Hz 11: 250 Hz 12: 125 Hz 13: 63.5 Hz 14: 31.25 Hz
HSCMode	INPUT	USINT	0, 2, 4, 6, 8, 10, 12
Start	INPUT	BOOL	Start counter.
Stop	INPUT	BOOL	Stop the counter and clear "MaxDPos" and "MaxDSpd" value.
FBENO	OUTPUT	BOOL	Function block Enable output.
IDCheck	OUTPUT	BOOL	TRUE: HSC plug-in is at selected slot. FALSE: Wrong plug-in or no plug-in at selected slot.
Initialized	OUTPUT	BOOL	TRUE: HSC plug-in initialization finished and ready to execute. FALSE: HSCplug-in initialization not yet finished.
Accumulator	OUTPUT	LINT	Accumulator value.
Rate	OUTPUT	Real	Current pulse rate. The rate calculation is based on how many pulses have been counted every 10 ms.

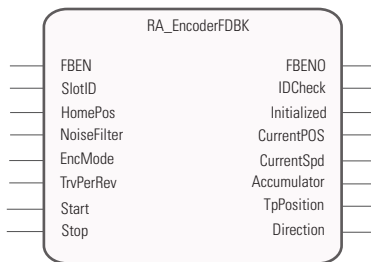

**RA\_EncoderFDBK**

**RA\_EncoderFDBK: Input and Output Parameters**

Parameter	Type	Data Type	Description
FBEN	INPUT	BOOL	Function block Enable input
SlotID	INPUT	UINT	Plug-in slot number. Slot ID = 1...5 (starting with the far left slot 1)
HomePos	INPUT	REAL	Home position. Same value indicated in MC_Home instruction.

### RA\_EncoderFDBK: Input and Output Parameters

Parameter	Type	Data Type	Description
NoiseFilter	INPUT	USINT	00 - No filter 01 - 250 kHz 02 - 200 kHz 03 - 80 kHz 04 - 40 kHz 05 - 13.3 kHz 06 - 10 kHz 07 - 4 kHz 08 - 2 kHz 09 - 1 kHz 10 - 500 Hz 11 - 250 Hz 12 - 125 Hz 13 - 62.5 Hz 14 - 31.25 Hz
EncMode	INPUT	USINT	Encoder Mode. 1-X1, 2- X2, 4-X4.
ECntPerRev	INPUT	REAL	User input to indicate how many X1 counts will be generated when Encoder disk turns one revolution.
TrvPerRev	INPUT	REAL	The actual distance travelled when motor turns one revolution.
Start	INPUT	BOOL	Start counter.
Stop	INPUT	BOOL	Stop the counter and clear MaxDPos and MaxDSpd value
FBENO	OUTPUT	BOOL	Function block enable output.
IDCheck	OUTPUT	BOOL	TRUE: HSC plug-in is at selected slot. FALSE: Wrong plug-in or no plug-in at selected slot.
Initialized	OUTPUT	BOOL	TRUE: Indicates HSC initialization has finished. FALSE: Indicates HSC initialization has not finished.
CurrentPos	OUTPUT	REAL	Current position.
CurrentSpd	OUTPUT	REAL	Current speed (Unit = user distance per second).
Accumulator	OUTPUT	LINT	Accumulator value.
TpPosition	OUTPUT	REAL	Position recorded when the latest touch probe is triggered.
Direction	OUTPUT	SINT	1 = Forward -1 = Reverse 0 = Not moving

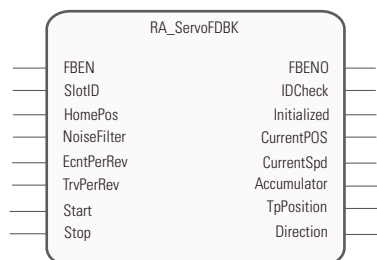

### RA\_ServoFDBK

#### RA\_ServoFDBK: Input and Output Parameters

Parameter	Type	Data Type	Description
FBEN	INPUT	BOOL	Function block Enable input
SlotID	INPUT	UINT	Plug-in slot number. Slot ID = 1...5 (starting with the far left slot 1)
HomePos	INPUT	REAL	Home position. Same value indicated in MC_Home instruction.

**RA\_ServoFDBK: Input and Output Parameters**

Parameter	Type	Data Type	Description
NoiseFilter	INPUT	USINT	00: No filter 01: 250 kHz 02: 200 kHz 03: 80 kHz 04: 40 kHz 05: 13.3 kHz 06: 10 kHz 07: 4 kHz 08: 2 kHz 09: 1 kHz 10: 500 Hz 11: 250 Hz 12: 125 Hz 13: 62.5 Hz 14: 31.25 Hz
EncMode	INPUT	USINT	Encoder Mode. 1-X1, 2- X2, 4-X4.
ECntPerRev	INPUT	REAL	User input to indicate how many X1 counts will be generated when Encoder disk turns one revolution.
TrvPerRev	INPUT	REAL	The actual distance travelled when motor turns one revolution.
Start	INPUT	BOOL	Start counter.
Stop	INPUT	BOOL	Stop the counter and clear MaxDPos and MaxDSpd value.
FBENO	OUTPUT	BOOL	Function block enable output.
IDCheck	OUTPUT	BOOL	TRUE: HSC plug-in is at selected slot. FALSE: Wrong plug-in or no plug-in at selected slot.
Initialized	OUTPUT	BOOL	TRUE: Indicates HSC initialization has finished. FALSE: Indicates HSC initialization has not finished.
CurrentPos	OUTPUT	REAL	Current position.
CurrentSpd	OUTPUT	REAL	Current speed (Unit = user distance per second).
Accumulator	OUTPUT	LINT	Accumulator value.
TpPosition	OUTPUT	REAL	Position recorded when the latest touch probe is triggered.
Direction	OUTPUT	SINT	1 = Forward -1 = Reverse 0 = Not moving

**Use the 2080-MOT-HSC Module**

For a step-by-step guide on how to use the Micro800 High Speed Counter plug-in, see [Quickstart Projects for 2080-MOT-HSC Plug-in on page 93](#).

## DeviceNet Plug-in – 2080-DNET20

### Overview

The DeviceNet plug-in serves as scanner and client for explicit messaging to remote devices. The module is designed to scan devices such as:

- CompactBlock™ LDX
- PowerFlex® drives
- E1Plus overloads
- stack lights

User-defined function blocks (UDFB) are required to enable interaction between these devices.

The 2080-DNET20 DeviceNet scanner supports a maximum of 20 nodes. For example, if the scanner ID is configured to zero, the scanner would scan from 1...20. It is supported on Micro800 controllers with available plug-in slots. Only one 2080-DNET20 DeviceNet scanner is supported per controller.

---

**IMPORTANT** Rockwell Automation recommends that only one 2080-DNET20 DeviceNet scanner be used for each network trunk-line.

---



---

**IMPORTANT** If the 2080-DNET20 DeviceNet scanner is control flashed to a new major firmware version (for example, from 1.xxx to 2.xxx or vice versa), once the plug-in is successfully upgraded, power cycle the controller.

---



---

**IMPORTANT** If RSLinx browsing is enabled, the CIP client messages can get timed out because the DeviceNet buffers are fully occupied by RSLinx messages. It is recommended not to have RSLinx browsing to the DeviceNet bridge if Client Messaging is required.

---

### Status Indicators

The DeviceNet plug-in module supports two standard DeviceNet green and red LED indicators:

- Module status
- Network status

**Module Status Indicator**

LED state	Module status	Description
OFF	No power	There is no power present.
Flashing Green	Operational	Unit is starting up.
Green	Unit operational	Device is operating normally.
Flashing Red	Minor fault.	A recoverable fault is present or the module is undergoing firmware update.
Red	Unrecoverable fault.	A non-recoverable fault is detected.

**Network Status Indicator**

LED state	Module Status	Description
OFF	No power or offline	There is no network power or device is not operating.
Flashing Green	Idle	No valid network connection has been made.
Green	Online	The plug-in module is operating normally and receiving messages.
Flashing Red	Connection time out	One or more network connections has timed out.
Red	Critical link failure	The plug-in module has detected an error that makes it incapable of communicating on the link (Bus Off or duplicate MAC_ID).

## Network Configuration

In order to configure the DeviceNet plug-in and scan the network, you need to import user-defined function blocks (UDFBs) in your Micro800 project in Connected Components Workbench. Autoscan is used to add nodes into the scan list.

**IMPORTANT** It is recommended that when Autoscan is running for the nodes in range, or for the connection to be established, the nodes should be idle without any pre-occupied connections requests.

## Network Wiring

The DeviceNet specifications provide for maximum network distances for the main trunk line and drop lines, depending upon the baud rate used on the network.

**Network Specifications**

Baud Rate	Trunk Line Length		Drop Length			
	Maximum Distance		Maximum		Cumulative	
	Meters	Feet	Meters	Feet	Meters	Feet
125k baud	420	1377	6	20	156	512
250k baud	200	656.17	6	20	78	256
500k baud	75	246	6	20	39	128



**IMPORTANT** Maximum power supply drop cable length is 3 m.

- TIP Recommended Cable**  
 Flat Cable (Kwiklink lite)  
 – Class 1 cable maximum allowable current 8A (NEC/CECode)  
 – Class 2 cable maximum allowable current 4A (NEC/CECode)

## DeviceNet Switches

### 2080-DNET20 Assembly Diagram

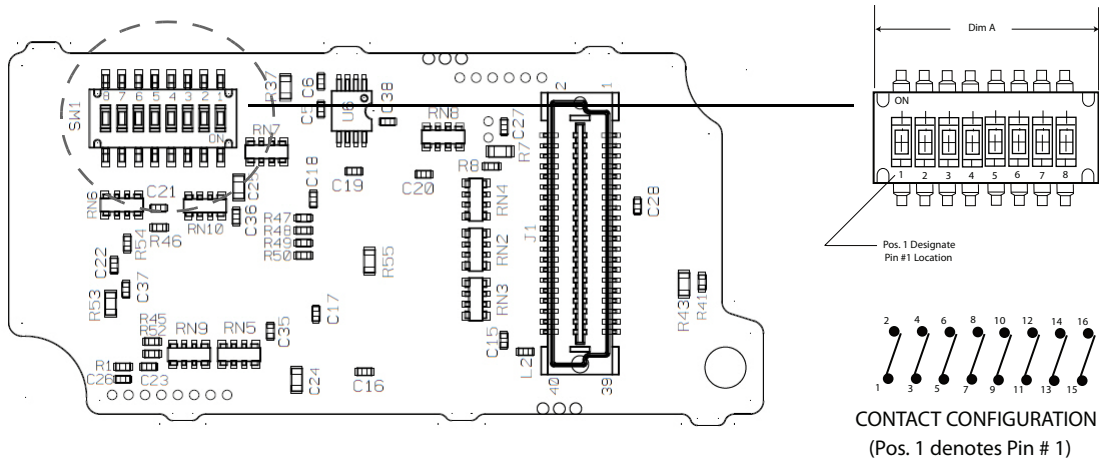

### DeviceNet Address (MAC\_ID) Switch Definitions

Node Address	SW1 Switch Positions					
	3	4	5	6	7	8
	Switch Position Values					
	32	16	8	4	2	1
0 (default)	OFF	OFF	OFF	OFF	OFF	OFF
1	OFF	OFF	OFF	OFF	OFF	ON
2	OFF	OFF	OFF	OFF	ON	OFF
3	OFF	OFF	OFF	OFF	ON	ON
4	OFF	OFF	OFF	ON	OFF	OFF
5	OFF	OFF	OFF	ON	OFF	ON
...						
62	ON	ON	ON	ON	ON	OFF
63	ON	ON	ON	ON	ON	ON

### DeviceNet Baud Rate Switch Definitions

Baud Rate DR (Data Rate)	SW1 Switch Position	
	1	2
125k	OFF	OFF
250k	OFF	ON
500k (default)	ON	OFF
Autobaud	ON	ON

---

**IMPORTANT** For most applications, Rockwell Automation recommends that you use default node and baud rate settings. The DeviceNet scanner plug-in will be at node 0 and the devices will be at nodes 1...20. The baud rate will be at 500k baud and the maximum trunkline length will be 75 m (KwikLink Lite).

---

### Power Supply

The plug-in module gets its power from the Micro800 backplane. However, the DeviceNet interface is isolated from the Micro800 system. Therefore, network power to operate the DeviceNet transceiver on the plug-in module is supplied by an external DeviceNet power supply.

If using a single power supply in the network, calculate the total current requirement of all devices in the network and add +10% for current surge. Recommended power supply is 1606-XLSDNET4.

### Power Supply Cable Dropline Length

Dropline Length	Allowable Current
1.5 m (5 ft)	3 A
2 m (6 ft)	2 A
3 m (10 ft)	1.5 A
4.5 m (15 ft)	1 A
6 m (20 ft)	0.75 A

If two or more power supplies are connected to the Kwiklink lite media (trunk cable) V+ should be broken between the two power supplies.

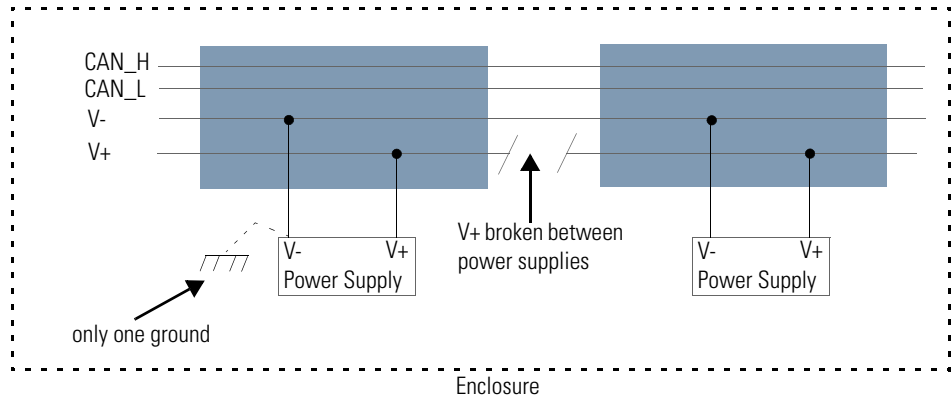

**TIP Grounding the network**

If grounding at only one location, it is recommended that you ground at the center of the network.

**Single Source Power Supply (End segment) Kwiklink Lite Cable**

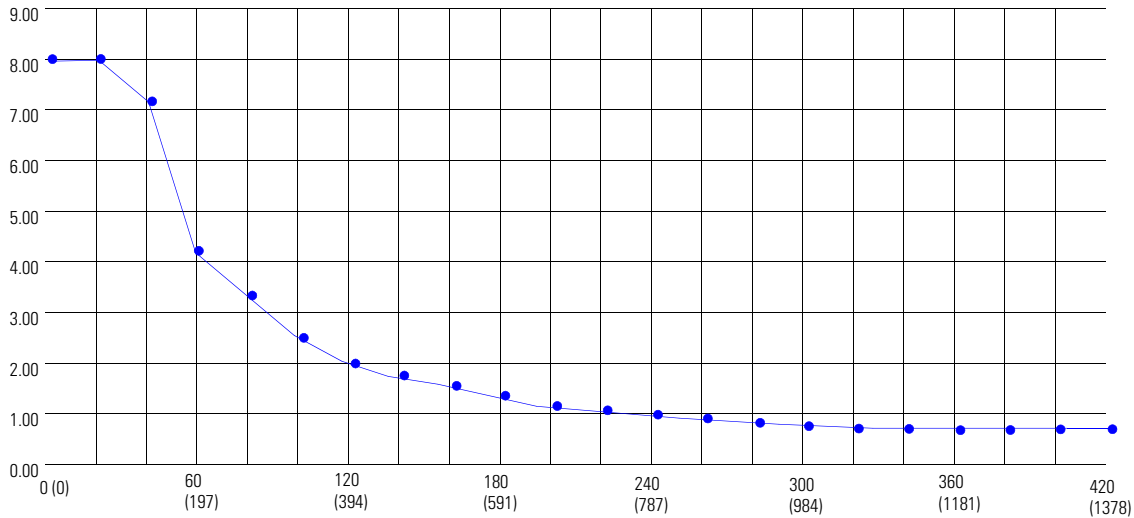

**Single Source Power Supply – Trunkline Length and Maximum Current**

Network Length in meter (ft)	Current, max	Network Length in meter (ft)	Current, max
0 (0)	8.00 <sup>(1)</sup>	220(722)	1.31
20 (66)	8.00 <sup>(1)</sup>	240 (787)	1.20
40 (131)	7.01 <sup>(1)</sup>	260 (853)	1.11
60 (197)	4.72 <sup>(1)</sup>	280 (919)	1.03
80 (262)	3.56	300 (984)	0.96
100 (238)	2.86	320 (1050)	0.90

**Single Source Power Supply – Trunkline Length and Maximum Current**

120 (394)	2.39	340 (1115)	0.85
140 (459)	2.05	360 (1181)	0.80
160 (525)	1.79	380 (1247)	0.76
180 (591)	1.60	400 (1312)	0.72
200 (656)	1.44	420 (1378)	0.69

(1) Exceeds NEC CL2/CECode 4A limit.

**Dual Source Power Supply (both ends – Kwiklink Lite Cable)**

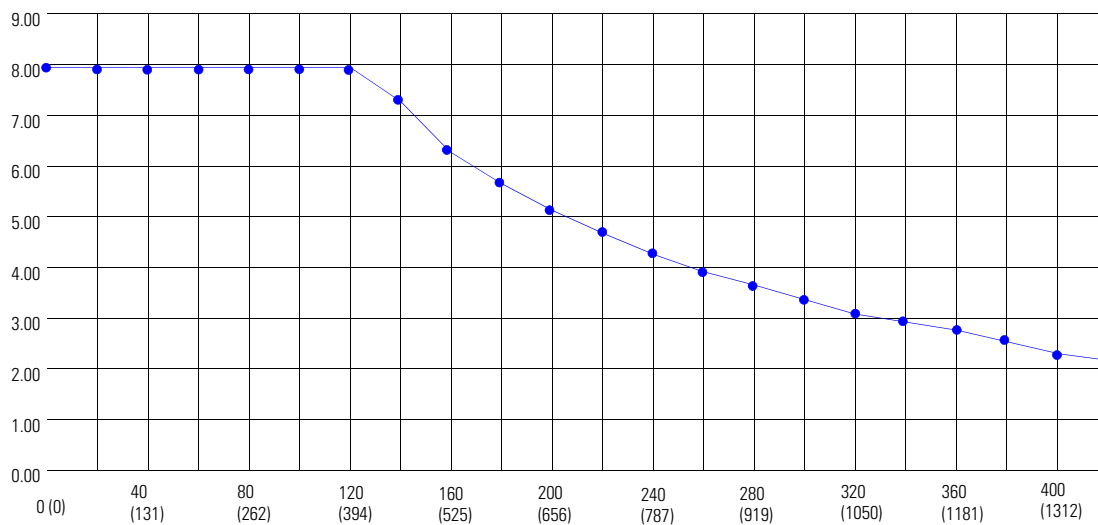

**Dual source power supply (both ends – Kwiklink Lite Cable)**

Network length in meters (ft)	Current, max	Network length in meters (ft)	Current, max
0 (0)	8.00 <sup>(1)</sup>	220 (722)	4.69
20 (66)	8.00	240 (787)	4.30
40 (131)	8.00	260 (853)	3.97
60 (197)	8.00	280 (919)	3.69
80 (262)	8.00	300 (984)	3.44
100 (328)	8.00	320 (1050)	3.23
120 (394)	8.00	340 (1115)	3.04
140 (459)	7.35	360 (1181)	2.87
160 (525)	6.43	380 (1247)	2.72
180 (591)	5.72	400 (1312)	2.59
200 (656)	5.16	420 (1378)	2.46

(1) Exceeds NEC CL2/CECode 4A limit.

### Calculate Voltage Requirement

$$\text{SUM} \{[(L_n * R_c) + (N_t * (0.005))] * I_n\} < 4.65 \text{ V}$$

Where:

$L_n$  = Length in meter or feet

$R_c$  = Resistance of the cable per meter or feet

(Kwiklink flat media = 0.019 ohms/meter or 0.0058/feet)

$N_t$  = Number of the node starting from 1 close to power supply and increasing.

0.005 = Nominal contact resistance used for every connection to the trunkline

$I_n$  = Current drawn from the cable system by the device.

**IMPORTANT** To calculate for percentage of loading, divide the total voltage calculated from the above formula by 4.65.

## User Defined Function Blocks

Download the following 2080-DNET20 user-defined function blocks from the Sample Code Library:

<http://www.rockwellautomation.com/go/scmicro800>

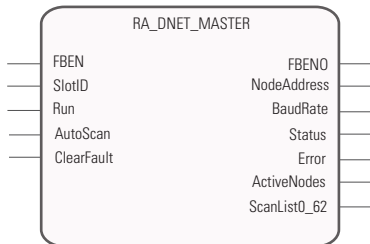

### RA\_DNET\_MASTER

This UDFB sets the 2080-DNET20 scanner to RUN mode.

#### RA\_DNET\_MASTER: Input and Output Parameters

Variable Name	Type	Data Type	Description
FBEN	INPUT	BOOL	TRUE: To continue reading and writing the scanner status. FBEN changed to level Triggered.
SlotID	INPUT	UINT	Plug-in slot number (1...5)
Run	INPUT	BOOL	TRUE: Set the scanner to RUN mode. FALSE: Scanner is in IDLE mode. AutoScan is enabled.
AutoScan	INPUT	BOOL	TRUE: AutoScan is enabled.
ClearFault	INPUT	BOOL	TRUE: Clear scanner fault. FALSE: No action.
FBENO	OUTPUT	BOOL	Function block enable output. TRUE upon exit.
NodeAddress	OUTPUT	USINT	Scanner node address. Default node address is 0.
BaudRate	OUTPUT	USINT	Network baud rate: 0: 125K 1: 250K 2: 500K 3: AutoBaud Default baud rate is 500K.
Status	OUTPUT	USINT	Scanner fault status. 0: No error.

**RA\_DNET\_MASTER: Input and Output Parameters**

Variable Name	Type	Data Type	Description
Error	OUTPUT	STRING	Scanner error description.
ActiveNodes	OUTPUT	USINT	Number of slave nodes in the network.
Scanlist0_62	OUTPUT	LWORD	Details on active node table, bit 0...62. Bit 0: Represent Node 0. Bit 62: Represent Node 62.

**Sequence of Operation: RA\_DNET\_MASTER**

Sequence	Run	Autoscan	Description
1	False	False	Reinitializes scan list from the plug-in scanner if FBEN = TRUE.
2	False	True	Triggers autoscan to scan the network after clearing scan list.
3	False	False	Puts scanner to IDLE mode by disabling autoscan if active node number = number of nodes in network.
4	True	False	Puts scanner to RUN mode.

Upon powerup, the scanner should be in IDLE Mode for the autoscan to start. Wait until the autoscan process is complete before turning the scanner to RUN Mode (that is, Run bit is TRUE).

*Sample Code*

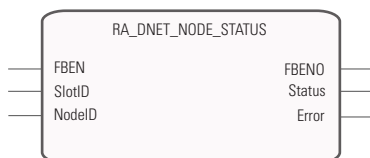
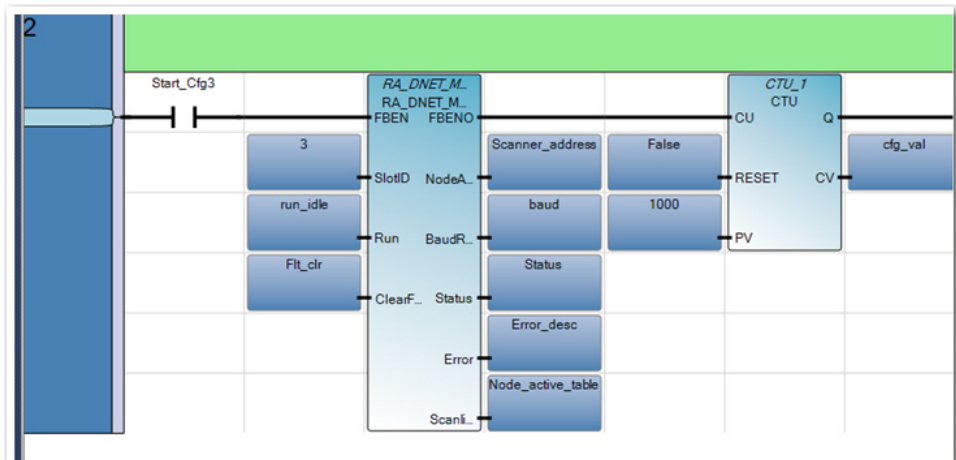

**RA\_DNET\_NODE\_STATUS**

This UDFB is used to read the node status of slave nodes in a DeviceNet network where the 2080-DNET20 scanner is connected.

**RA\_DNET\_NODE\_STATUS: Input and Output Parameters**

Variable Name	Type	Data Type	Description
FBEN	INPUT	BOOL	Function block enable input. TRUE to enable the function.
SlotID	INPUT	UINT	Plug-in slot number (1...5)
NodeID	INPUT	USINT	Slave node address.
FBENO	OUTPUT	BOOL	Function block enable output. TRUE upon exit.
Status	OUTPUT	USINT	Scanner fault status. 0: No errors.
Error	OUTPUT	STRING	Description of the node status error.

Sample Code: RA\_DNET\_NODE\_STATUS

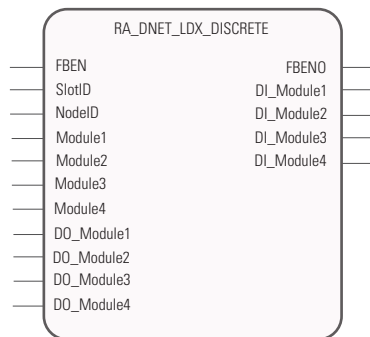
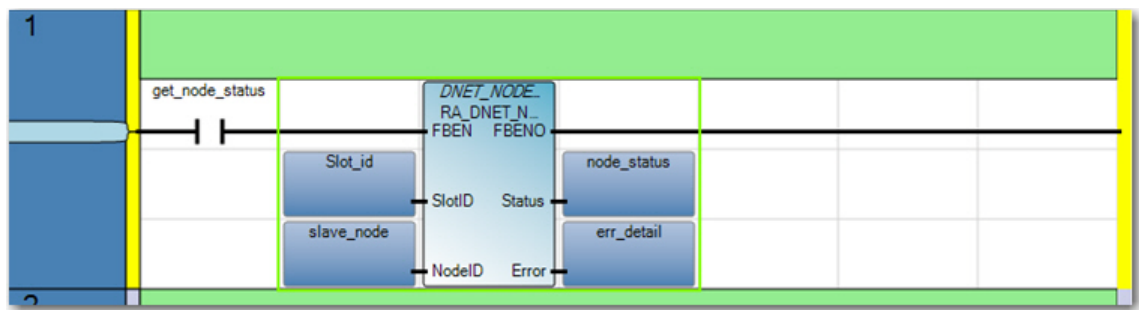

**RA\_DNET\_LDX\_DISCRETE**

This UDFB is used for I/O data exchange with discrete CompactBlock I/O.

**RA\_DNET\_LDX\_DISCRETE: Input and Output Parameters**

Variable Name	Type	Data Type	Description
FBEN	INPUT	BOOL	Function block enable input. TRUE to enable the function block.
SlotID	INPUT	UINT	Plug-in slot number (1...5)
NodeID	INPUT	USINT	Node address of the digital Compact I/O slave node.
Module1	INPUT	STRING	Base module I/O configuration. INPUT X OUTPUT Channels For example: 16X0 (16 input / 0 output is physically present as base module) Valid String: 32X0, 0X32, 16X0, 0X16, 16X16, 8X8, 8X0, 0X8, 0X6 NOTE: X should always be upper case.
Module2	INPUT	STRING	Expansion module 1 I/O configuration. INPUT X OUTPUT channels For example: 16X0 (16 input / 0 output is physically present as base module) Valid String: 32X0, 0X32, 16X0, 0X16, 16X16, 8X8, 8X0, 0X8, 0X6 NOTE: X should always be upper case.

**RA\_DNET\_LDX\_DISCRETE: Input and Output Parameters**

Variable Name	Type	Data Type	Description
Module3	INPUT	STRING	Expansion module 2 I/O configuration. INPUT X OUTPUT Channels For example: 16X0 (16 input / 0 Output is physically present as base module) Valid String: 32X0, 0X32, 16X0, 0X16, 16X16, 8X8, 8X0, 0X8, 0X6 NOTE: X should always be upper case.
Module4	INPUT	STRING	Expansion module 3I/O configuration. INPUT X OUTPUT Channels For example: 16X0 (16 input / 0 output is physically present as base module) Valid String: 32X0, 0X32, 16X0, 0X16, 16X16, 8X8, 8X0, 0X8, 0X6 NOTE: X should always be upper case.
DO_Module1	INPUT	UDINT	Output data for base module.
DO_Module2	INPUT	UDINT	Output data for expansion module 1.
DO_Module3	INPUT	UDINT	Output data for expansion module 2.
DO_Module4	INPUT	UDINT	Output data for expansion module 3.
FBENO	OUTPUT	BOOL	Function block enable output. TRUE upon exit.
DI_Module1	OUTPUT	UDINT	Input data from base module (Module 1).
DI_Module2	OUTPUT	UDINT	Input data from expansion module 1 (Module 2).
DI_Module3	OUTPUT	UDINT	Input data from expansion module 2 (Module 3).
DI_Module4	OUTPUT	UDINT	Input data from expansion module 3 (Module 4).

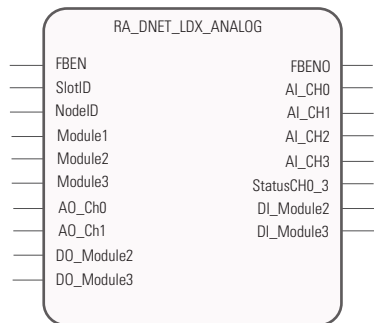

**RA\_DNET\_LDX\_ANALOG**

This UDFB is used for data exchange with analog CompactBlock I/O.

**RA\_DNET\_LDX\_ANALOG: Input and Output Parameters**

Variable Name	Type	Data Type	Description
FBEN	INPUT	BOOL	Function block enable input. TRUE to enable the function.
SlotID	INPUT	UINT	Plug-in slot number (1...5)
NodeID	INPUT	USINT	Slave node address.
Module1 <sup>(1)</sup>	INPUT	STRING	Analog base module I/O configuration. INPUT X OUTPUT Channels For example: 4X0 (4 input analog module is physically present as base module) Valid String: 0X2, 4X0 NOTE: X should always be upper case.
Module2 <sup>(1)</sup>	INPUT	STRING	Digital expansion module 1 I/O configuration. INPUT X OUTPUT Channels For example: 16X16 (16 input / 16 output is physically present as expansion module 1) Valid String: 16X0, 0X16, 16X16, 8X8, 8X0, 0X8, 0X6 NOTE: X should always be upper case.



**RA\_DNET\_LDX\_ANALOG: Input and Output Parameters**

Variable Name	Type	Data Type	Description
Module3 <sup>(1)</sup>	INPUT	STRING	Digital expansion module 2 I/O configuration. INPUT X OUTPUT channels For example: 16X16 (16 input / 16 output is physically present as expansion module 2) Valid String: 16X0, 0X16, 16X16, 8X8, 8X0, 0X8, 0X6 NOTE: X should always be upper case.
AO_Ch0	INPUT	WORD	Analog Output Channel 0 value. This value is valid only if Module1 = '0X2'
AO_Ch0	INPUT	WORD	Analog Output Channel 1 value. This value is valid only if Module1 = '0X2'
DO_Module2	INPUT	UINT	Output data for Expansion Module 1.
DO_Module3	INPUT	UINT	Output Data for Expansion Module 2.
FBENO	OUTPUT	BOOL	Function block enable output. TRUE upon exit.
AI_CH0	OUTPUT	WORD	Analog Input Channel 0 value. This value is valid only if Module1 = '4X0'
AI_CH1	OUTPUT	WORD	Analog Input Channel 1 value. This value is valid only if Module1 = '4X0'
AI_CH2	OUTPUT	WORD	Analog Input Channel 2 value. This value is valid only if Module1 = '4X0'
AI_CH3	OUTPUT	WORD	Analog Input Channel 3 Value. This value is valid only if Module1 = '4X0'
StatusCH0_3	OUTPUT	WORD	Analog input channel 0...3 status
DI_Module2	OUTPUT	UINT	Digital Expansion Module 1 Input Data. Applicable only if catalog is with digital inputs.
DI_Module3	OUTPUT	UINT	Digital Expansion Module 2 Input Data. Applicable only if catalog is with digital inputs.

(1) Use only valid strings combinations as mentioned above. If Module1, Module2, Module3 physical I/O does not match the physical I/O present in base and expansion, then incorrect sequence will be written.

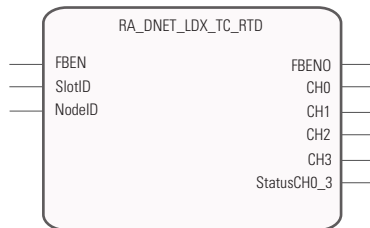

**RA\_DNET\_LDX\_TC\_RTD**

This UDFB is used to read input data from the Thermocouple/RTD module.

**RA\_DNET\_LDX\_TC\_RTD: Input and Output Parameters**

Variable Name	Type	Data Type	Description
FBEN	INPUT	BOOL	Function block enable input. TRUE to enable function.
SlotID	INPUT	UINT	Plug-in slot number (1...5)
NodeID	INPUT	USINT	Node address of the digital Compact I/O slave node.
FBENO	OUTPUT	BOOL	Function block enable output.
CH0	OUTPUT	WORD	RTD/Thermocouple input channel 0 value.
CH1	OUTPUT	WORD	RTD/Thermocouple input channel 1 value.

**RA\_DNET\_LDX\_TC\_RTD: Input and Output Parameters**

Variable Name	Type	Data Type	Description
CH2	OUTPUT	WORD	RTD/Thermocouple input channel 2 value.
CH3	OUTPUT	WORD	RTD/Thermocouple input channel 3 value.
StatusCH0_3	OUTPUT	WORD	RTD/Thermocouple Input channel 0...3 status.



**RA\_DNET\_TOWERLIGHT**

This UDFB is used for data exchange with a towerlight or stacklight.

**RA\_DNET\_TOWERLIGHT: Input and Output Parameters**

Variable Name	Type	Data Type	Description
FBEN	INPUT	BOOL	Function block enable input. TRUE to enable the function.
SlotID	INPUT	UINT	Plug-in slot number (1...5)
NodeID	INPUT	USINT	Towerlight node address.
Light_0_4	INPUT	USINT	Light 0...4, for example: Bit 0: Blue Bit 1: Yellow Bit 2: Red
FBENO	OUTPUT	BOOL	Function block enable output. TRUE upon exit.
Status_0_4	OUTPUT	USINT	Light 0...4 status.

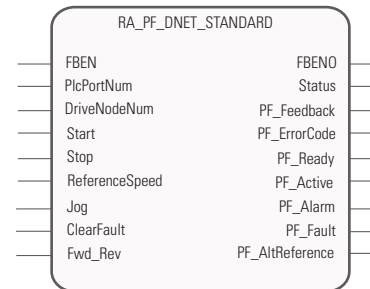

**RA\_PF\_DNET\_STANDARD**

This UDFB is used for I/O data exchange with standard PowerFlex drives configured as single mode.

**RA\_PF\_DNET\_STANDARD: Input and Output Parameters**

Variable Name	Type	Data Type	Description
FBEN	INPUT	BOOL	Function block enable input. TRUE to enable the function.
PlcPortNum	INPUT	UINT	Plug-in slot number (1...5 for plug-in slots).
DriveNodeNum	INPUT	USINT	Slave node address for PowerFlex drive.
Start	INPUT	BOOL	TRUE to start PowerFlex drive.
Stop	INPUT	BOOL	TRUE to stop PowerFlex drive.
ReferenceSpeed	INPUT	REAL	Reference speed for the device. Configure PowerFlex drive speed.
Jog	INPUT	BOOL	TRUE to enable jog in PowerFlex drive.
ClearFault	INPUT	BOOL	TRUE to clear fault in PowerFlex drive.
Fwd_Rev	INPUT	BOOL	TRUE to configure PowerFlex drive for forward motion. FALSE to configure PowerFlex drive for reverse motion.
FBENO	OUTPUT	BOOL	Function block enable output. TRUE upon exit.

**RA\_PF\_DNET\_STANDARD: Input and Output Parameters**

Variable Name	Type	Data Type	Description
Status	OUTPUT	BOOL	PowerFlex drive status.
PF_Feedback	OUTPUT	REAL	Feedback from the PowerFlex drive.
PF_ErrorCode	OUTPUT	INT	For future use.
PF_Ready	OUTPUT	BOOL	Ready bit from PowerFlex drive.
PF_Active	OUTPUT	BOOL	Active bit from PowerFlex drive.
PF_Alarm	OUTPUT	BOOL	Alarm bit from PowerFlex drive.
PF_Fault	OUTPUT	BOOL	Fault bit from PowerFlex drive.
PF_AltReference	OUTPUT	BOOL	Alt Reference bit from PowerFlex drive.

**IMPORTANT** Ensure that your PowerFlex drives settings are correct. For basic setup configuration, see the PowerFlex drives user manuals in the [Rockwell Automation Literature Library](#).

With PowerFlex 523, you need to multiply the speed reference and divide the speed feedback by a factor of 10.0 in order to get the correct value. Note that the PowerFlex 4 and PowerFlex 5 drives have a different multiplier.

**Reference and Feedback for the Different PowerFlex Drives**

Drive Type	Number	Reference	Feedback
PowerFlex 4M	132	x10	x0.1
PowerFlex 4	39	x10	x0.1
PowerFlex 40	40	x100	x0.1
PowerFlex 40P	41	x100	x0.01
PowerFlex 400	129	x100	x0.01
PowerFlex 523	8	x100	x0.01
PowerFlex 525	9	x100	x0.01

For example, if you set reference speed at 50, command speed is 50 Hz for PowerFlex 4M and only 5 Hz for PowerFlex 523 and PowerFlex 525.

**RA\_PF\_DNET\_MULTIDRIVE**

This UDFB is used for I/O data exchange with standard PowerFlex drives, configured as multi-drive.

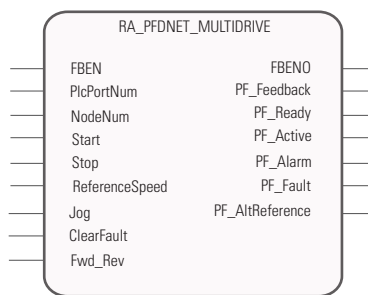

**RA\_PF\_DNET\_MULTIDRIVE: Input and Output Parameters**

Variable Name	Type	Data Type	Description
FBEN	INPUT	BOOL	Function block enable input. TRUE to enable the function.
PlcPortNum	INPUT	UINT	Plug-in slot number (1...5 for plug-in slots).
NodeNum	INPUT	USINT	DeviceNet node address for PowerFlex drive (connected as master in multi-drive setup).
Start	INPUT	BOOL[1...5]	TRUE to start each element of the array. Corresponds to each drive. For example: Start[1] for Drive 1 and Start[5] for Drive5.
Stop	INPUT	BOOL[1...5]	TRUE to stop each element of the array. Corresponds to each drive, for example, Stop [1] for Drive 1 and Stop [5] for Drive5.
ReferenceSpeed	INPUT	REAL[1...5]L	Reference speed to set the device speed. Each element of the array corresponds to each drive, for example, Reference Speed [1] for Drive 1 and Reference Speed [5] for Drive5.
Jog	INPUT	BOOL[1...5]	TRUE to enable jog in PowerFlex drive. Each element of the array corresponds to each drive, for example, Reference Jog [1] for Drive 1 and Jog [5] for Drive5.
ClearFault	INPUT	BOOL[1...5]	TRUE to clear fault in PowerFlex drive. Each element of the array corresponds to each drive, for example, ClearFault [1] for Drive 1 and ClearFault [5] for Drive5.
Fwd_Rev	INPUT	BOOL[1...5]	TRUE to configure PowerFlex drive for forward motion. FALSE to configure PowerFlex drive for Reverse motion. Each element of the array corresponds to each drive, for example, Fwd_Rev[1] for Drive 1 and Fwd_Rev [5] for Drive5.
FBENO	OUTPUT	BOOL	Function block enable output. TRUE upon exit.
PF_Feedback	OUTPUT	REAL[1...5]	Speed reference from the PowerFlex drive. Each element of the array corresponds to each drive, for example, PF_Feedback[1] for Drive 1 and PF_Feedback[5] for Drive5.
PF_Ready	OUTPUT	BOOL[1...5]	Ready bit from PowerFlex drive. Each element of the array corresponds to each drive, for example, PF_Ready[1] for Drive 1 and PF_Ready[5] for Drive5.
PF_Active	OUTPUT	BOOL[1...5]	Active bit from PowerFlex drive. Each element of the array corresponds to each drive, for example, PF_Active[1] for Drive 1 and PF_Active[5] for Drive5.

**RA\_PF\_DNET\_MULTIDRIVE: Input and Output Parameters**

Variable Name	Type	Data Type	Description
PF_Alarm	OUTPUT	BOOL[1...5]	Alarm bit from PowerFlex drive. Each element of the array corresponds to each drive, for example, PF_Alarm[1] for Drive 1 and PF_Alarm[5] for Drive5.
PF_Fault	OUTPUT	BOOL[1...5]	Fault bit from PowerFlex drive. Each element of the array corresponds to each drive, for example, PF_Fault[1] for Drive 1 and PF_Fault[5] for Drive5.
PF_AltReference	OUTPUT	BOOL[1...5]	Alt Reference bit from PowerFlex drive. Each element of the array corresponds to each drive, for example, PF_AltReference[1] for Drive 1 and PF_AltReference[5] for Drive5.

**IMPORTANT** Ensure that your PowerFlex drives settings are correct. For basic setup configuration, see the PowerFlex drives user manuals in the [Rockwell Automation Literature Library](#).

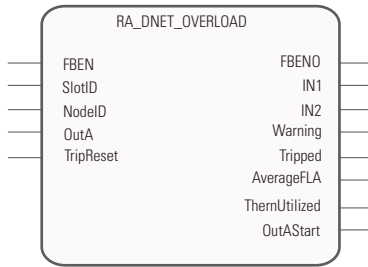

**RA\_DNET\_OVERLOAD**

This UDFB is used for I/O data exchange with an overload relay.

**RA\_DNET\_OVERLOAD: Input and Output Parameters**

Variable Name	Type	Data Type	Description
FBEN	INPUT	BOOL	Function block enable input. TRUE to enable the function.
SlotID	INPUT	UINT	Plug-in slot number (1...5 for plug-in slots).
NodeID	INPUT	USINT	DeviceNet node address of the slave node.
OutA	INPUT	BOOL	TRUE to turn on Output A.
TripReset	INPUT	BOOL	TRUE to enable Trip Reset.
FBENO	OUTPUT	BOOL	Function block enable output. TRUE upon exit.
IN1	OUTPUT	BOOL	Input 1 from overload relay.
IN2	OUTPUT	BOOL	Input 2 from overload relay.
Warning	OUTPUT	BOOL	TRUE if warning is enabled.
Tripped	OUTPUT	BOOL	TRUE if tripped.
AverageFLA	OUTPUT	WORD	Average FLA % value from overload relay.
ThermUtilized	OUTPUT	WORD	Therm Utilized value from overload relay.
OutAStatus	OUTPUT	WORD	Average FLA value from overload relay.

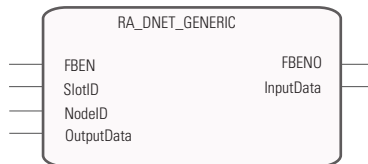

**RA\_DNET\_GENERIC**

This UDFB is used for I/O data exchange with generic I/O devices.

**RA\_DNET\_GENERIC: Input and Output Parameters**

Variable Name	Type	Data Type	Description
FBEN	INPUT	BOOL	Function block enable input. TRUE to enable function.
SlotID	INPUT	UINT	Plug-in slot number (1...5 for plug-in slots).
NodeID	INPUT	USINT	Slave node address.
OutputData	INPUT	USINT[1...64]	Slave output data.
FBENO	OUTPUT	BOOL	Function block enable output. TRUE to enable function.
InputData[1...64]	OUTPUT	USINT[1...64]	Input data from slave.

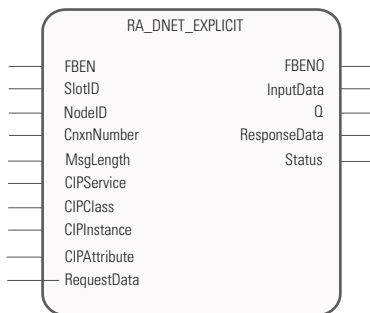

**RA\_DNET\_EXPLICIT**

This UDFB is used for sending explicit message to slave node.

**IMPORTANT** For DNET explicit message, the maximum payload supported is 256 bytes.

**RA\_DNET\_EXPLICIT: Input and Output Parameters**

Variable Name	Type	Data Type	Description
FBEN	INPUT	BOOL	Function block enable input. TRUE to enable function.
SlotID	INPUT	UINT	Plug-in slot number (1...5 for plug-in slots).
NodeID	INPUT	USINT	Node address of slave node.
CnxnNumber	INPUT	USINT	Connection number values 1, 2, 3, 4, 5.
MsgLength	INPUT	USINT	Specifies the size of the CIP message in the transaction block.
CIPService	INPUT	UINT	CIP service code.
CIPClass	INPUT	UINT	CIP Class code (valid values 0...65535).
CIPInstance	INPUT	UINT	CIP instance (valid values 0...65535).
CIPAttribute	INPUT	UINT	CIP attribute (valid values 0...65535).
RequestData	INPUT	USINT[1...54]	Request data from slave.
FBENO	OUTPUT	BOOL	Function block enable output.
Q	OUTPUT	BOOL	TRUE when message is sent out successfully.
Error	OUTPUT	BOOL	TRUE when message transmits error.
ResponseData	OUTPUT	USINT [1...50]	CIP Response error Response Data[1] : Extended Error ID Response Data[2] : Error ID  See <a href="#">Explicit Message Request Format on page 55</a> . See <a href="#">Explicit Message Status Codes on page 55</a> .
Status	OUTPUT	USINT	See <a href="#">Explicit Message Status Codes on page 55</a> .

**Transaction Block Format**

Byte Offset	Contents
0	Status
1	Transaction ID
2	Size
3	Reserved
4	MAC ID
5	Service
6...115	Transaction Body (110 bytes)

**Explicit Message Request Format**

Byte Offset	Contents
0	Status
1	Transaction ID
2	Size
3	Reserved
4	MAC ID
5	Service
6...7	Class
8...9	Instance
10...115	Service Data (106 Bytes)

**Explicit Message Response Format**

Byte Offset	Contents
0	Status
1	Transaction ID
2	Size
3	Reserved
4	MAC ID
5	Service

Byte Offset	Contents	Request Data
0	Status	Can be read from UDFB status
6...115	ServiceData	Can be read from UDFB response data. Response data shows CIP error Code.

**Explicit Message Status Codes**

Status Code	Description
0	Ignore transaction block (block empty).

**Explicit Message Status Codes**

1	Transaction completed successfully.
2	Transaction in progress (not ready).
4	Error – node offline
5	Error – DeviceNet port disabled/offline
6	Error – Transaction TXID unknown
7	Error – Duplicate TXID
9	Error – Scanner out of buffers
12	Error – Response data too large for block
14	Error – Invalid size specified
15	Error – Device timed out
16	Block queued.
17	Block allocated
18	Connection in progress
3, 8, 10, 11, 13, 19...255	Reserved

**Send Explicit Messages to 2080-DNET20 Plug-in Using Micro800 Pass Through**

MSG\_CIPGENERIC instruction can be used to send Explicit messages to the 2080-DNET20 plug-in and the Slave nodes on the DeviceNet network.

In MSG\_CIPGENERIC, configure the target path as mentioned below:

- To access the plug-in, the format of the target path is “1, Slot number”.
- To access a Slave device through the plug-in, the format of the target path is “1, Slot number, 2, DeviceNet node address”.

For example, if the 2080-DNET20 plug-in is connected at physical slot 3 and the Slave device of address 40 is present in the DeviceNet network, then:

- Using MSG\_CIPGENERIC to access the plug-in, the target path would be “1, 3”.
- Using MSG\_CIPGENERIC to access the Slave node through the plug-in, the target path would be “1, 3, 2, 40”.

Note that the number “1” refers to the Virtual backplane port number and “2” refers to the 2080-DNET20 plug-in's DeviceNet port number. These are fixed values. The slot number starts from 1 up to the maximum number of slots physically present in the controller.

When the controller pass through feature is used in the following example:

Micro850 → Micro820 [192.168.1.100] → 2080-DNET20 plug-in [Slot 3] → Slave device [Node 40]

- Using MSG\_CIPGENERIC starting from Micro850 to access the plug-in, the target path would be “4, 192.168.1.100, 1, 3”



- Using MSG\_CIPGENERIC starting from Micro850, the Slave device cannot be accessed because the MSG\_CIPGENERIC target path configuration is limited to a single hop. This path will work if you use a Logix controller/PC instead of Micro850.

Note that the number “4” refers to the EtherNet/IP port number (for Serial the port number varies from 2...5. See the controller’s user manual for detailed information).

---

<b>IMPORTANT</b>	To use the controller pass through feature, the following firmware revisions are required: <ul style="list-style-type: none"> <li>• Micro820/Micro830/Micro850 controller firmware revision 8.011 or higher.</li> <li>• 2080-DNET20 plug-in firmware revision 2.011 or higher.</li> </ul>
------------------	---

---

## Error Codes

### DeviceNet plug-in Error Codes and Descriptions

ErrorID	Description
0	No errors.
1	Node number not in scanlist.
65	AutoScan active.
70	Scanner failed DUP MAC check.
71	Illegal value in scanlist.
72	Device stopped communicating.
73	Device does not match scanlist.
74	Scanner has detected data overrun.
75	No network traffic detected.
76	No network traffic detected for scanner.
77	Data size returned does not match scanlist.
78	Device on scanlist not active on subnet.
79	Scanner failed to transmit a message.
80	Scanner is in Idle mode operation.
81	Scanner is in fault mode operation.
82	I/O fragment out of sequence.
83	Device refused to be initialized.
84	Device not yet initialized.
85	Incorrect data size upon connection with device.
86	Device/Slave went into Idle.
87	Shared master has not allocated slave.
88	Shared master has not allocated required choices.
89	Keeper download failed.

### DeviceNet plug-in Error Codes and Descriptions

ErrorID	Description
90	User has disabled scanner.
91	Bus Off detected on scanner.
92	No network power detected.
93	CRC failure detected on one or more configuration blocks.
95	Scanner application program flash is being updated.
96	Port is in test mode.
97	Scanner is halted by user.
98	ESC, overflow, divide or other processor error.
99	Scanner watchdog has timed out.

### Use the 2080-DNET20 Plug-in

For a step-by-step guide on how to use the DeviceNet plug-in, see [Quickstart Project for 2080-DNET20 Plug-in on page 88](#).

## Specifications

### Digital Plug-in Modules

#### General Specifications – 2080-OB4, 2080-OV4, 2080-IQ4OB4, 2080-IQ4OV4, 2080-IQ4

Attribute	Value
Mounting torque	0.2 Nm (1.48 lb-in.)
Status indicators	For input or output modules – 4 yellow For combination modules – 8 yellow
Terminal base screw torque	0.22...0.25 Nm (1.95...2.21 lb-in.) using a 2.5 mm (0.10 in.) flat-blade screwdriver
Enclosure type rating	None (open-style)
Isolation voltage	<b>For input modules</b> 50V (continuous), Basic Insulation Type, Inputs to Backplane Type tested for 60 s @ 720 V DC, Inputs to Backplane <b>For combination or output modules</b> 50V (continuous), Basic Insulation Type, Inputs to Outputs, I/Os to Backplane Type tested for 60 s @ 720 V DC, I/Os to Backplane
Wire size	1.3... 0.2 mm <sup>2</sup> (16...24 AWG) solid or stranded copper wire rated @ 90 °C (194 °F), or greater, insulation max
Wire category	2 – on signal ports 2 – on power ports
North American temp code	T4

#### Input Specifications – 2080-IQ4, 2080-IQ4OV4, 2080-IQ4OB4

Attribute	Value
DC on-state voltage, min	9.0V DC
DC on-state voltage, max	30V DC
DC on-state current, min	2.0 mA @ 9V DC
DC on-state current, nom	3.0 mA @ 24V DC
DC on-state current, max	5.0 mA
DC off-state voltage, max	5V DC
DC off-state current, max	1.5 mA
IEC input compatibility	Type 3
Input impedance	0...3V, >4 K $\Omega$ 3...12V, 3.5 K $\Omega$ min 12...30V, >4 K $\Omega$ <10 K $\Omega$
Input filter time ON to OFF	8...10 ms AC/DC
AC on-state voltage, min	10.25V AC (rms)
AC on-state voltage, max	30V AC (rms)

**Input Specifications – 2080-IQ4, 2080-IQ4OV4, 2080-IQ4OB4**

Attribute	Value
AC on-state current, min	2.0 mA @ 9V AC (rms)
AC on-state current, max	5.0 mA
AC off-state voltage	3.5V AC (rms)

**Output Specifications – 2080-OB4, 2080-OV4, 2080-IQ4OB4, 2080-IQ4OV4**

Attribute	Value
Power supply voltage	10.8V DC, min 30V DC, max
On-state voltage	10V DC, min 24V DC, nom 30V DC, max
On-state current	5.0 mA @ 10V DC, min 0.5 A max, steady state 2 A surge, 2 s min

**Environmental Specifications – 2080-OB4, 2080-OV4, 2080-IQ4OB4, 2080-IQ4OV4, 2080-IQ4**

Attribute	Value
Temperature, operating	IEC60068-2-1 (Test Ad, Operating Cold), IEC60068-2-2, (Test Bd, Operating Dry Heat), IEC 60068-2-14 (Test Nb, Operating Thermal Shock): -20...65 °C (-4...149 °F)
Temperature, surrounding air, max.	65 °C (149 °F)
Temperature, non-operating	IEC60068-2-1 (Test Ad, Operating Cold), IEC60068-2-2, (Test Bd, Operating Dry Heat), IEC 60068-2-14 (Test Nb, Operating Thermal Shock): -40...85 °C (-40...185 °F)
Relative humidity	IEC 60068-2-30 (Test Db, Unpackaged Damp Heat): 5...95% noncondensing
Vibration	IEC 60068-2-6 (Test Fc, Operating): 2 g @ 10...500 Hz
Shock, operating	IEC 60068-2-27 (Test Ea, Unpackaged Shock): DIN rail mounting: 25 g Panel mounting: 35 g
Shock, non-operating	IEC 60068-2-27 (Test Ea, Unpackaged Shock): 25 g
Emissions	CISPR 11: Group 1, Class A
ESD Immunity	IEC 61000-4-2: 4 kV contact discharges 8 kV air discharges
Radiated RF immunity	IEC 61000-4-3: 10 V/M with 1 kHz sine-wave 80%AM from 80...2000 MHz 10 V/M with 200 Hz 50% Pulse 100%AM @ 900 MHz 10 V/M with 200 Hz 50% Pulse 100%AM @1890 MHz 10 V/M with 1 kHz sine-wave 80%AM from 2000...2700 MHz

**Environmental Specifications – 2080-OB4, 2080-OV4, 2080-IQ4OB4, 2080-IQ4OV4, 2080-IQ4**

Attribute	Value
EFT/B immunity	±2 kV @ 5 kHz on signal ports
Surge transient immunity	±1 kV line-line(DM) and ±2 kV line-earth(CM) on signal ports
Conducted RF immunity	10V rms with 1 kHz sine-wave 80%AM from 150 kHz. . . 80 MHz

**Certifications – 2080-OB4, 2080-OV4, 2080-IQ4OB4, 2080-IQ4OV4, 2080-IQ4**

Certification (when product is marked) <sup>(1)</sup>	Value
c-UL-us	UL Listed Industrial Control Equipment, certified for US and Canada. See UL File E322657.  UL Listed for Class I, Division 2 Group A,B,C,D Hazardous Locations, certified for U.S. and Canada. See UL File E334470.
CE	European Union 2004/108/EC EMC Directive, compliant with: EN 61326-1; Meas./Control/Lab., Industrial Requirements EN 61000-6-2; Industrial Immunity EN 61000-6-4; Industrial Emissions EN 61131-2; Programmable Controllers (Clause 8, Zone A & B)
C-Tick	Australian Radiocommunications Act, compliant with: AS/NZS CISPR 11; Industrial Emissions
KC	Korean Registration of Broadcasting and Communications Equipment, compliant with: Article 58-2 of Radio Waves Act, Clause 3

(1) See the Product Certification link at <http://www.rockwellautomation.com/products/certification/> for Declarations of Conformity, Certificates, and other certification details.

**General Specifications – 2080-OW4I Digital Relay Output Plug-in Module**

Attribute	Value
Mounting torque	0.2 Nm (1.48 lb-in.)
Status indicators	4 yellow
Terminal base screw torque, max	0.19 Nm (1.7 lb-in.) using a 2.5 mm [0.10 in.] flat-blade screwdriver
Wire size	0.05...1.31 mm <sup>2</sup> (30...16 AWG) solid copper wire rated @ 90 °C (194 °F) insulation max
Enclosure type rating	None (open-style)
Isolation voltage	240V (continuous), Reinforce Insulation Type, between Output Channels and Output channels to Backplane Type tested for 60 s @ 1480 V AC Outputs to Outputs, Outputs to Backplane
Insulation stripping length	5 mm
Wiring category	2 – on signal ports 2 – on power ports
Wire type	Copper
North American temp code	T4
Inrush current	<120 mA @ 3.3V <120 mA @ 24V

**General Specifications – 2080-OW4I Digital Relay Output Plug-in Module**

Attribute	Value
Backplane power	3.3 VDC, 38 mA
Output current, resistive	2 A @ 5...30V DC 0.5 A @ 48V DC 0.22 A @ 125V DC 2 A @ 125V AC 2 A @ 240V AC
Output current, inductive	1.0 A steady state @ 5...28V DC 0.93 A steady state @ 30V DC 0.5 A steady state @ 48V DC 0.22 A steady state @ 125V DC 2.0 A steady state, 15 A make @ 125V AC, PF – cos $\theta$ = 0.4 2.0 A steady state, 7.5 A make @ 240V AC, PF – cos $\theta$ = 0.4
Output power, resistive, max	250 VA for 125V AC resistive loads 480 VA for 240V AC resistive loads 60 VA for 30V DC resistive loads 24 VA for 48V DC resistive loads 27.5 VA for 125V DC resistive loads
Pilot duty rating	C300, R150
Minimum load, per point	10 mA
Initial contact resistance of relay, max	30 m $\Omega$
Output delay time, max	10 ms ON or OFF

**Relay Contact Ratings (0.35 power factor) – 2080-OW4I**

Maximum Volts	Amperes		Amperes Continuous	Volt-Amperes	
	Make	Break		Make	Break
120V AC	15 A	1.5 A	2.0 A	1800 VA	180 VA
240V AC	7.5 A	0.75 A			
24V DC	1.0 A			28 VA	
125V DC	0.22 A				

**Environmental Specifications – 2080-OW4I**

Attribute	Value
Temperature, operating	IEC60068-2-1 (Test Ad, Operating Cold), IEC60068-2-2, (Test Bd, Operating Dry Heat), IEC 60068-2-14 (Test Nb, Operating Thermal Shock): -20...65 °C (-4...149 °F)
Temperature, surrounding air, max.	65 °C (149 °F)
Temperature, non-operating	IEC60068-2-1 (Test Ad, Operating Cold), IEC60068-2-2, (Test Bd, Operating Dry Heat), IEC 60068-2-14 (Test Nb, Operating Thermal Shock): -40...85 °C (-40...185 °F)
Relative humidity	IEC 60068-2-30 (Test Db, Unpackaged Damp Heat): 5...95% noncondensing
Vibration	IEC 60068-2-6 (Test Fc, Operating): 2 g @ 10...500 Hz
Shock, operating	IEC 60068-2-27 (Test Ea, Unpackaged Shock): 10 g

**Environmental Specifications – 2080-OW4I**

<b>Attribute</b>	<b>Value</b>
Shock, non-operating	IEC 60068-2-27 (Test Ea, Unpackaged Shock): DIN rail mounting: 25 g Panel mounting: 35 g
ESD Immunity	IEC 61000-4-2: 6kV contact 8 kV air
Radiated RF immunity	IEC 61000-4-3 10 V/M with 1 kHz sine-wave 80%AM from 80...2000 MHz 10 V/M with 200 Hz sine-wave 50% Pulse 100%AM @ 900 MHz 10 V/M with 200 Hz sine-wave 50% Pulse 100%AM @1890 MHz 10 V/M with 1 kHz sine-wave 80%AM from 2000...2700 MHz
EFT/B immunity	IEC 61000-4-4: ±2 kV @ 5 kHz on signal ports
Surge transient immunity	IEC 61000-4-5: ±1 kV line-line(DM) and ±2 kV line-earth(CM) on signal ports
Conducted RF immunity	IEC 61000-4-6: 10V rms with 1 kHz sine-wave 80%AM from 150 kHz...80 MHz

**Certifications – 2080-OW4I**

<b>Certification (when product is marked)<sup>(1)</sup></b>	<b>Value</b>
c-UL-us	UL Listed Industrial Control Equipment, certified for US and Canada. See UL File E322657.  UL Listed for Class I, Division 2 Group A,B,C,D Hazardous Locations, certified for U.S. and Canada. See UL File E334470.
CE	European Union 2004/108/EC EMC Directive, compliant with: EN 61326-1; Meas./Control/Lab., Industrial Requirements EN 61000-6-2; Industrial Immunity EN 61000-6-4; Industrial Emissions EN 61131-2; Programmable Controllers (Clause 8, Zone A & B)  European Union 2006/95/EC LVD, compliant with:EN 61131-2; Programmable Controllers (Clause 11)
C-Tick	Australian Radiocommunications Act, compliant with: AS/NZS CISPR 11; Industrial Emissions
KC	Korean Registration of Broadcasting and Communications Equipment, compliant with: Article 58-2 of Radio Waves Act, Clause 3

(1) See the Product Certification link at <http://www.rockwellautomation.com/products/certification/> for Declarations of Conformity, Certificates, and other certification details.

## Analog Plug-in Modules

### Input Specifications – 2080-IF2, 2080-IF4

Attribute	2080-IF2	2080-IF4
Number of inputs, single ended	2	4
Analog normal operating ranges	Voltage: 0...10V DC Current: 0...20 mA	
Resolution, max.	12 bits unipolar, with software selected option for 50 Hz, 60 Hz, 250 Hz, 500 Hz	
Data range	0...65535	
Input impedance	Voltage Terminal: > 220K $\Omega$ , Current Terminal: 250 $\Omega$	
Overall accuracy <sup>(1)</sup>	Voltage Terminal: $\pm 1\%$ full scale @ 25°C Current Terminal: $\pm 1\%$ full scale @ 25°C	
Non-linearity (in percent full scale)	$\pm 0.1\%$	
Repeatability <sup>(2)</sup>	$\pm 0.1\%$	
Module error over full temperature range, -20...65°C (-4...149°F)	Voltage: $\pm 1.5\%$ Current: $\pm 2.0\%$	
Input channel configuration	Through configuration software or the user program	
Field input calibration	Not required	
Update time	180 ms per enabled channel	
Input group to bus isolation	No isolation	
Channel to channel isolation	Non-isolation	
Temperature, operating	IEC 60068-2-1 (Test Ad, Operating Cold), IEC 60068-2-2 (Test Bd, Operating Dry Heat), IEC 60068-2-14 (Test Nb, Operating Thermal Shock): -20...65 °C (-4...149 °F)	
Temperature, non-operating	IEC 60068-2-1 (Test Ab, Unpackaged Nonoperating Cold), IEC 60068-2-2 (Test Bb, Unpackaged Nonoperating Dry Heat), IEC 60068-2-14 (Test Na, Unpackaged Nonoperating Thermal Shock): -40...85 °C (-40...185 °F)	
Relative humidity	IEC 60068-2-30 (Test Db, Unpackaged Damp Heat): 5%...95% non-condensing	
Operating altitude	2000 m	
Cable length, max.	10 m	

(1) Includes offset, gain, non-linearity and repeatability error terms.

(2) Repeatability is the ability of the input module to register the same reading in successive measurements for the same input signal.

### Output Specifications – 2080-OF2

Attribute	2080-OF2
Number of outputs, single ended	2
Analog normal operating ranges	Voltage: 10V DC Current: 0...20 mA
Resolution, max.	12 bits unipolar
Output count range	0...65535
D/A Conversion Rate (all channels), max.	2.5 ms



**Output Specifications – 2080-OF2**

<b>Attribute</b>	<b>2080-OF2</b>
Step Response to 63% <sup>(1)</sup>	5 ms
Current Load In voltage output, max	10 mA
Resistive load on current output	0...500 $\Omega$ (includes wire resistance)
Load range on voltage output	> 1k $\Omega$ @ 10V DC
Max. inductive load (current outputs)	0.01 mH
Max. capacitive load (voltage outputs)	0.1 $\mu$ F
Overall Accuracy <sup>(2)</sup>	Voltage Terminal: $\pm 1\%$ full scale @ 25 °C Current Terminal: $\pm 1\%$ full scale @ 25 °C
Non-linearity (in percent full scale)	$\pm 0.1\%$
Repeatability <sup>(3)</sup> (in percent full scale)	$\pm 0.1\%$
Output error over full temperature range, -20...65°C (-4...149°F)	Voltage: $\pm 1.5\%$ Current: $\pm 2.0\%$
Open and short-circuit protection	Yes
Output overvoltage protection	Yes
Input group to bus isolation	No isolation
Channel to channel isolation	Non-isolation
Temperature, operating	IEC 60068-2-1 (Test Ad, Operating Cold), IEC 60068-2-2 (Test Bd, Operating Dry Heat), IEC 60068-2-14 (Test Nb, Operating Thermal Shock): -20...65 °C (-4...149 °F)
Temperature, non-operating	IEC 60068-2-1 (Test Ab, Unpackaged Nonoperating Cold), IEC 60068-2-2 (Test Bb, Unpackaged Nonoperating Dry Heat), IEC 60068-2-14 (Test Na, Unpackaged Nonoperating Thermal Shock): -40...85 °C (-40...185 °F)
Relative humidity	IEC 60068-2-30 (Test Db, Unpackaged Damp Heat): 5...95% non-condensing
Operating altitude	2000 m
Cable length, max.	10 m

(1) Step response is the period of time between when the D/A converter was instructed to go from minimum to full range until the device is at 63% of full range.

(2) Includes offset, gain, non-linearity and repeatability error terms.

(3) Repeatability is the ability of the output module to reproduce output readings when the same controller value is applied to it consecutively, under the same conditions and in the same direction.

**Certifications – 2080-IF2, 2080-IF4, 2080-OF2**

Certification (when product is marked) <sup>(1)</sup>	Value
c-UL-us	UL Listed Industrial Control Equipment, certified for US and Canada. See UL File E322657.  UL Listed for Class I, Division 2 Group A,B,C,D Hazardous Locations, certified for U.S. and Canada. See UL File E334470.
CE	European Union 2004/108/EC EMC Directive, compliant with: EN 61326-1; Meas./Control/Lab., Industrial Requirements EN 61000-6-2; Industrial Immunity EN 61000-6-4; Industrial Emissions EN 61131-2; Programmable Controllers (Clause 8, Zone A & B)  European Union 2006/95/EC LVD, compliant with: EN 61131-2; Programmable Controllers (Clause 11)
C-Tick	Australian Radiocommunications Act, compliant with: AS/NZS CISPR 11; Industrial Emissions

(1) See the Product Certification link at <http://www.rockwellautomation.com/products/certification/> for Declarations of Conformity, Certificates, and other certification details.

**Specialty Plug-in Modules**

**Specifications – 2080-MEMBAK-RTC**

Attribute	Value
Resolution READ_RTC()	1 s
Accuracy	± 5 sec/month @ 25 °C ± 9 sec/month @ -20...65 °C
Power off	Battery — 3.5 years from date of manufacture @ 25...65 °C, 2.5 years from date of manufacture @ 0 °C
Temperature, operating	IEC 60068-2-1 (Test Ab, Unpackaged Nonoperating Cold), IEC 60068-2-2 (Test Bb, Unpackaged Nonoperating Dry Heat), IEC 60068-2-14 (Test Na, Unpackaged Nonoperating Thermal Shock): -20...65 °C (-4...149 °F)
Temperature, nonoperating	IEC 60068-2-1 (Test Ab, Unpackaged Nonoperating Cold), IEC 60068-2-2 (Test Bb, Unpackaged Nonoperating Dry Heat), IEC 60068-2-14 (Test Na, Unpackaged Nonoperating Thermal Shock): -40...85 °C (-40...185 °F)
Relative humidity	IEC 60068-2-30 (Test Db, Unpackaged Damp Heat): 5...95% non-condensing
Altitude, operating	2000 m

**IMPORTANT** Battery life does not include controller ON time. For example, if the Controller is ON for 16 hours every day for 365 days, if the module starts being used after 1 year of manufacturing, battery life is 8.5 years (1 year initial time + 2.5 years of Off time out of 7.5 years).

**Specifications – 2080-TRIMPOT6**

Attribute	Value
Data range	0...255
Number of trimpot	6
Temperature, operating	IEC 60068-2-1 (Test Ad, Operating Cold), IEC 60068-2-2 (Test Bd, Operating Dry Heat), IEC 60068-2-14 (Test Nb, Operating Thermal Shock): -20...65 °C (-4...149 °F)
Temperature, nonoperating	IEC 60068-2-1 (Test Ab, Unpackaged Nonoperating Cold), IEC 60068-2-2 (Test Bb, Unpackaged Nonoperating Dry Heat), IEC 60068-2-14 (Test Na, Unpackaged Nonoperating Thermal Shock): -40...85 °C (-40...185 °F)
Temperature, surrounding air, max	65 °C (149 °F)
Relative humidity	IEC 60068-2-30 (Test Db, Unpackaged Damp Heat): 5%...95% non-condensing
Altitude, operating	2000 m

**Certifications – 2080-TRIMPOT6**

Certification (when product is marked) <sup>(1)</sup>	Value
c-UL-us	UL Listed Industrial Control Equipment, certified for US and Canada. See UL File E322657.  UL Listed for Class I, Division 2 Group A,B,C,D Hazardous Locations, certified for U.S. and Canada. See UL File E334470.
CE	European Union 2004/108/EC EMC Directive, compliant with: EN 61326-1; Meas./Control/Lab., Industrial Requirements EN 61000-6-2; Industrial Immunity EN 61000-6-4; Industrial Emissions EN 61131-2; Programmable Controllers (Clause 8, Zone A & B)
C-Tick	Australian Radiocommunications Act, compliant with: AS/NZS CISPR 11; Industrial Emissions

(1) See the Product Certification link at <http://www.rockwellautomation.com/products/certification/> for Declarations of Conformity, Certificates, and other certification details.

**General and Environmental Specifications – 2080-TC2, 2080-RTD2**

Attribute	2080-RTD2	2080-TC2
Mounting torque	0.2 Nm (1.48 lb-in.)	
Terminal screw torque	0.22...0.25 Nm (1.95...2.21 lb-in.) using a 2.5 mm (0.10 in.) flat-blade screwdriver	
Wire size	0.14...1.5 mm <sup>2</sup> (26...16 AWG) solid copper wire or 0.14...1.0 mm <sup>2</sup> (26...17 AWG) stranded copper wire rated @ 90 °C (194 °F) insulation max	
Input impedance	> 5 MΩ	> 300 KΩ
Common mode rejection ratio	100 dB 50/60Hz	
Normal mode rejection ratio	70 dB @ 50/60 Hz	
Resolution	14-bit	

**General and Environmental Specifications – 2080-TC2, 2080-RTD2**

Attribute	2080-RTD2	2080-TC2
CJC error	—	±1.2 °C @ 25 °C (77 °F)
Accuracy	±1.0 °C for TC and RTD @ 25 °C (77 °F)	
Channels	2, non-isolated	
RTD types supported	100 Ω Platinum 385 200 Ω Platinum 385 500 Ω Platinum 385 1000 Platinum 385 100 Ω Platinum 392 200 Ω Platinum 392, 500 Ω Platinum 392 1000 Ω Platinum 392 10 Ω Copper 427 120 Ω Nickel 672 604 Ω Nickel-Iron 518	—
Thermocouple types supported	—	J, K, N, T, E, R, S, B
Open circuit detection time	8...1212 ms	8...1515 ms
Power consumption	3.3 V, 40 mA	
Temperature, surrounding air, max.	65 °C (149 °F)	
Temperature, operating	IEC60068-2-1 (Test Ad, Operating Cold), IEC60068-2-2, (Test Bd, Operating Dry Heat), IEC 60068-2-14 (Test Nb, Operating Thermal Shock): -20...65 °C (-4...149 °F)	
Temperature, nonoperating	IEC60068-2-1 (Test Ad, Operating Cold), IEC60068-2-2, (Test Bd, Operating Dry Heat), IEC 60068-2-14 (Test Nb, Operating Thermal Shock): -40...85 °C (-40...185 °F)	
North American temp code	T4	

**Certifications – 2080-TC2, 2080-RTD2**

Certification (when product is marked) <sup>(1)</sup>	Value
c-UL-us	UL Listed Industrial Control Equipment, certified for US and Canada. See UL File E322657.  UL Listed for Class I, Division 2 Group A,B,C,D Hazardous Locations, certified for U.S. and Canada. See UL File E334470.
CE	European Union 2004/108/EC EMC Directive, compliant with: EN 61326-1; Meas./Control/Lab., Industrial Requirements EN 61000-6-2; Industrial Immunity EN 61000-6-4; Industrial Emissions EN 61131-2; Programmable Controllers (Clause 8, Zone A & B)
C-Tick	Australian Radiocommunications Act, compliant with: AS/NZS CISPR 11; Industrial Emissions

(1) See the Product Certification link at <http://www.rockwellautomation.com/products/certification/> for Declarations of Conformity, Certificates, and other certification details.

**General Specifications – 2080-MOT-HSC**

Attribute	Value											
Dimensions, HxWxD, approx.	62 x 31.5 x 20 mm (2.44 x 1.24 x 0.79 in.)											
Terminal screw torque	0.22...0.25 Nm (1.95...2.21 lb-in.) using a 2.5 mm (0.10 in.) flat-blade screwdriver											
Bus current draw	60 mA @ 3.3V DC											
Recommended cable	Individually shielded, twisted-pair cable (or the type recommended by the encoder or sensor manufacturer)											
Wire size	<table border="1"> <thead> <tr> <th></th> <th>Min</th> <th>Max</th> <th></th> </tr> </thead> <tbody> <tr> <td>Solid</td> <td>0.14 mm<sup>2</sup> (26 AWG)</td> <td>1.5 mm<sup>2</sup> (16 AWG)</td> <td rowspan="2">rated @ 90 °C (194 °F) insulation max</td> </tr> <tr> <td>Stranded</td> <td>0.14 mm<sup>2</sup> (26 AWG)</td> <td>1.0 mm<sup>2</sup> (18 AWG)</td> </tr> </tbody> </table>		Min	Max		Solid	0.14 mm <sup>2</sup> (26 AWG)	1.5 mm <sup>2</sup> (16 AWG)	rated @ 90 °C (194 °F) insulation max	Stranded	0.14 mm <sup>2</sup> (26 AWG)	1.0 mm <sup>2</sup> (18 AWG)
	Min	Max										
Solid	0.14 mm <sup>2</sup> (26 AWG)	1.5 mm <sup>2</sup> (16 AWG)	rated @ 90 °C (194 °F) insulation max									
Stranded	0.14 mm <sup>2</sup> (26 AWG)	1.0 mm <sup>2</sup> (18 AWG)										
Enclosure type rating	Meets IP20											
Isolation voltage	Input module: 50V (continuous), Basic Insulation Type, Inputs/ Outputs to Backplane Type tested for 60s @ 720V DC, Inputs/Outputs to Backplane											
Wiring Category <sup>(1)</sup>	2 – on signal ports											
North American Temp Code	T4											

(1) Use this Conductor Category information for planning conductor routing. Refer to Industrial Automation Wiring and Grounding Guidelines, publication [1770-4.1](#).

**Input Specifications – 2080-MOT-HSC**

Attribute	Value
Number of inputs	1 Quadrature (ABZ) differential input
Maximum count	48 bits
Input voltage range	0...30V DC
On state voltage range	2.6...30V DC
On-state current, min	2.0 mA
Off-state voltage, max	1.0V DC
Off-state leakage current, max	1.5 mA
Input current range	2.0...9.0 mA
Input impedance, nom	3580 Ω
Pulse width, min	2 μs
Phase separation, min	500 ns <sup>(1)</sup>
Input frequency, max	250 kHz (50% duty)

(1) Phase separation is the recognition of phase time of A input and B input.

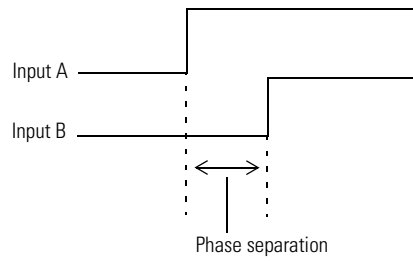

**Output Specifications – 2080-MOT-HSC**

Attribute	Value
Number of outputs	16 (1 physical output; 15 virtual)
Output voltage range	5...30V DC
Output on-state current, max	0.5 A
Output on-state current, min	1 mA
On-state voltage drop, max	0.5V DC
Off-state leakage current, max	0.5 mA
Turn ON time, max	2 ms
Turn OFF time, max	2 ms
Reverse polarity protection	None

*Temperature Derating*

**Maximum input voltage – 24V DC operation**

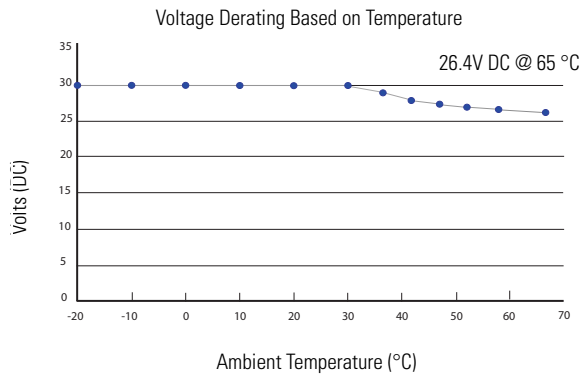

**Maximum output voltage – 24V DC operation**

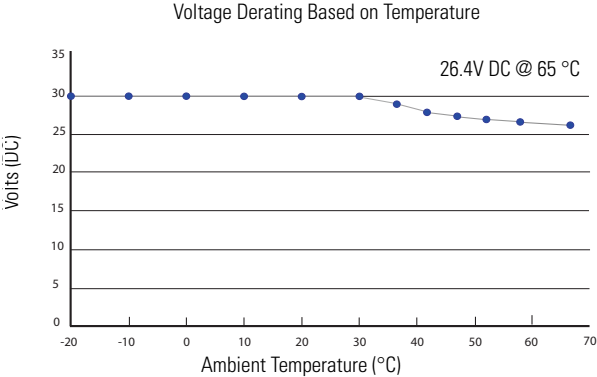

**Maximum output current per point – 5V DC operation**

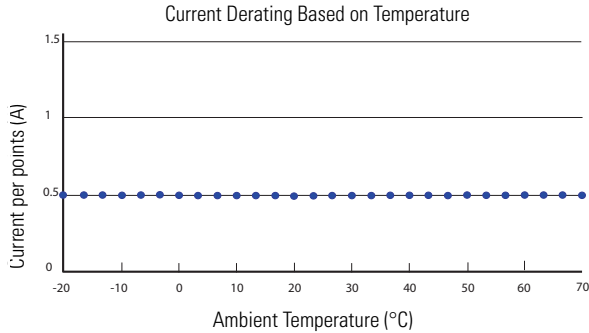

**Maximum output current per point – 24V DC operation**

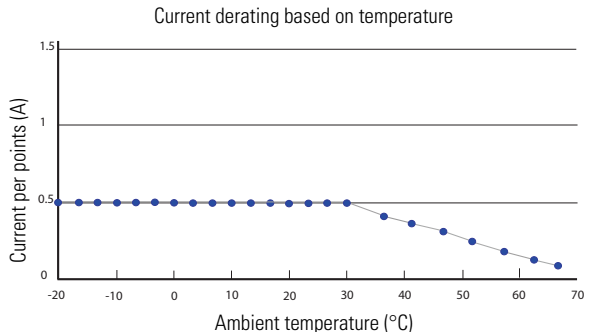

**Environmental Specifications – 2080-MOT-HSC**

Attribute	Value
Temperature, operating	IEC 60068-2-1 (Test Ad, Operating Cold), IEC 60068-2-2 (Test Bd, Operating Dry Heat), IEC 60068-2-14 (Test Nb, Operating Thermal Shock): -20...65 °C (-4...149 °F)
Temperature, nonoperating	IEC 60068-2-1 (Test Ab, Unpackaged Nonoperating Cold), IEC 60068-2-2 (Test Bb, Unpackaged Nonoperating Dry Heat), IEC 60068-2-14 (Test Na, Unpackaged Nonoperating Thermal Shock): -40...85 °C (-40...185 °F)
Temperature, surrounding air, max	65 °C (149 °F)
Relative humidity	IEC 60068-2-30 (Test Db, Unpackaged Damp Heat): 5...95% noncondensing
Vibration	IEC 60068-2-6 (Test Fc, Operating): 2 g @ 10...500 Hz
Shock, operating	IEC 60068-2-27 (Test Ea, Unpackaged Shock): 25 g
Shock, nonoperating	IEC 60068-2-27 (Test Ea, Unpackaged Shock): 25 g 35 g (PANEL mount)
Emissions	CISPR 11 (IEC 61000-6-4): Class A
ESD immunity	IEC 61000-4-2: 6 kV contact discharges 8 kV air discharges
Radiated RF immunity	IEC 61000-4-3: 10V/m with 1 kHz sine-wave 80% AM from 80...2000 MHz 10V/m with 200 Hz 50% Pulse 100% AM @ 900 MHz 10V/m with 200 Hz 50% Pulse 100% AM @ 1890 MHz 10V/m with 1 kHz sine-wave 80% AM from 2000...2700 MHz
EFT/B immunity	IEC 61000-4-4: ±2 kV @ 5 kHz on signal ports
Surge transient immunity	IEC 61000-4-5: ±2 kV line-earth(CM) on shielded ports
Conducted RF immunity	IEC 61000-4-6: 10V rms with 1 kHz sine-wave 80% AM from 150 kHz...80 MHz



**Certifications – 2080-MOT-HSC**

<b>Certification (when product is marked)<sup>(1)</sup></b>	<b>Value</b>
c-UL-us	UL Listed Industrial Control Equipment, certified for US and Canada. See UL File E322657.  UL Listed for Class I, Division 2 Group A,B,C,D Hazardous Locations, certified for U.S. and Canada. See UL File E334470.
CE	EN 61326-1; Meas./Control/Lab., Industrial Requirements EN 61000-6-2; Industrial Immunity EN 61000-6-4; Industrial Emissions EN 61131-2; Programmable Controllers (Clause 8, Zone A & B)
RCM	Australian Radiocommunications Act, compliant with: AS/NZS CISPR 11; Industrial Emissions
KC	Korean Registration of Broadcasting and Communications Equipment, compliant with: Article 58-2 of Radio Waves Act, Clause 3

(1) See the Product Certification link at <http://www.rockwellautomation.com/products/certification/> for Declarations of Conformity, Certificates, and other certification details.

## Communication Plug-in Modules

**Specifications – 2080-DNET20**

<b>Attribute</b>	<b>Value</b>
Screw torque	See <a href="#">Torque Specifications for the 2080-DNET20 Plug-in Module on page 74</a> .
Dimensions, HxWxD	62 x 31.5 x 20 mm (2.44 x 1.24 x 0.78 in.)
Weight	35 g
DeviceNet communication rate, max	125 Kbps – 420 m (1378 ft.) 250 Kbps – 200 m (656 ft.) 500 Kbps – 75 m (246 ft.)
Number of nodes, max	20 nodes for I/O operation
Network Protocol	I/O Slave Messaging: Poll Command
DeviceNet Status indicators	Module status – red/green Network status – red/green
Enclosure type rating	Meets IP20
Backplane power consumption	50 mA @ 24V DC
DeviceNet current	24V DC, 300 mA Class 2
Power dissipation, max	1.44 W
Isolation voltage	50V (continuous) Type tested for 60 s @ 500V AC
Wire size	0.25... 2.5 mm <sup>2</sup> (24...14 AWG) solid or stranded copper wire rated @ 75 °C (167 °F), or greater, 1.2 mm (3/64 in.) insulation max
Wire category	1 – on power ports
North American temp code	T4
Preferred power supply	1606-XLSDNET4

**Torque Specifications for the 2080-DNET20 Plug-in Module**

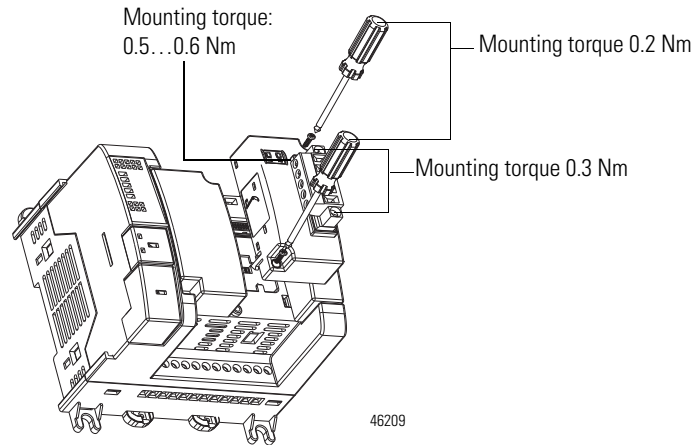

**ATTENTION:** To comply with CE Low Voltage Directive (LVD), this equipment and all connected I/O must be powered from a source compliant with the following: Safety Extra Low Voltage (SELV) or Protected Extra Low Voltage (PELV).



**ATTENTION:** To comply with UL restrictions, this equipment must be powered from a source compliant with the following: Class 2 or Limited Voltage/Current.

**Environmental Specifications – 2080-DNET20**

Attribute	Value
Temperature, operating	IEC 60068-2-1 (Test Ad, Operating Cold), IEC 60068-2-2 (Test Bd, Operating Dry Heat), IEC 60068-2-14 (Test Nb, Operating Thermal Shock): -20...65 °C (-4...149 °F)
Temperature, surrounding air, max.	65 °C (149 °F)
Temperature, nonoperating	IEC60068-2-1 (Test Ad, Operating Cold), IEC60068-2-2, (Test Bd, Operating Dry Heat), IEC 60068-2-14 (Test Nb, Operating Thermal Shock): -40...85 °C (-40...185 °F)
Relative humidity	IEC 60068-2-30 (Test Db, Unpackaged Damp Heat): 5...95% noncondensing
Emissions	CISPR 11 (IEC 61000-6-4): Class A
ESD Immunity	IEC 61000-4-2: 6 kV contact discharges 8 kV air discharges
Radiated RF immunity	IEC 61000-4-3: 10V/m with 1 kHz sine-wave 80% AM from 80...2000 MHz 10V/m with 200 Hz 50% Pulse 100% AM @ 900 MHz 10V/m with 200 Hz 50% Pulse 100% AM @ 1890 MHz 10V/m with 1 kHz sine-wave 80% AM from 2000...2700 MHz

**Environmental Specifications – 2080-DNET20**

<b>Attribute</b>	<b>Value</b>
EFT/B immunity	IEC 61000-4-4: ±4 kV @ 5 kHz on power ports ±2 kV @ 5 kHz on communication ports
Surge transient immunity	IEC 61000-4-5: ±1 kV line-line(DM) and ±2 kV line-earth(CM) on power ports ±2 kV line-earth(CM) on communication ports
Conducted RF immunity	IEC 61000-4-6: 10V rms with 1 kHz sine-wave 80% AM from 150 kHz...80 MHz

**Certifications – 2080-DNET20**

Certification (when product is marked) <sup>(1)</sup>	Value
c-UL-us	UL Listed Industrial Control Equipment, certified for US and Canada. See UL File E322657.  UL Listed for Class I, Division 2 Group A,B,C,D Hazardous Locations, certified for U.S. and Canada. See UL File E334470.
CE	EN 61326-1; Meas./Control/Lab., Industrial Requirements EN 61000-6-2; Industrial Immunity EN 61000-6-4; Industrial Emissions EN 61131-2; Programmable Controllers (Clause 8, Zone A & B)
C-Tick	Australian Radiocommunications Act, compliant with: AS/NZS CISPR 11; Industrial Emissions
KC	Korean Registration of Broadcasting and Communications Equipment, compliant with: Article 58-2 of Radio Waves Act, Clause 3
DeviceNet	ODVA conformance tested to DeviceNet specifications.

(1) See the Product Certification link at <http://www.rockwellautomation.com/products/certification/> for Declarations of Conformity, Certificates, and other certification details.

**General and Environmental Specifications – 2080-SERIALISOL**

Attribute	Value											
Mounting torque	0.2 Nm (1.48 lb-in)											
Terminal screw torque	0.22...0.25 Nm (1.95...2.21 lb-in) (using a 2.5 mm (0.10 in.) flat-blade screwdriver)											
Wire size	<table border="1"> <thead> <tr> <th></th> <th>UL</th> <th>UL</th> <th></th> </tr> </thead> <tbody> <tr> <td>Solid</td> <td>0.14 mm<sup>2</sup> (26 AWG)</td> <td>1.5 mm<sup>2</sup> (16 AWG)</td> <td rowspan="2">rated @ 90 °C (194 °F) insulation max</td> </tr> <tr> <td>Stranded</td> <td>0.14 mm<sup>2</sup> (26 AWG)</td> <td>1.0 mm<sup>2</sup> (18 AWG)</td> </tr> </tbody> </table>		UL	UL		Solid	0.14 mm <sup>2</sup> (26 AWG)	1.5 mm <sup>2</sup> (16 AWG)	rated @ 90 °C (194 °F) insulation max	Stranded	0.14 mm <sup>2</sup> (26 AWG)	1.0 mm <sup>2</sup> (18 AWG)
	UL	UL										
Solid	0.14 mm <sup>2</sup> (26 AWG)	1.5 mm <sup>2</sup> (16 AWG)	rated @ 90 °C (194 °F) insulation max									
Stranded	0.14 mm <sup>2</sup> (26 AWG)	1.0 mm <sup>2</sup> (18 AWG)										
Isolated voltage	500V AC											
Temperature, operating	IEC60068-2-1 (Test Ad, Operating Cold), IEC60068-2-2, (Test Bd, Operating Dry Heat), IEC 60068-2-14 (Test Nb, Operating Thermal Shock): -20...65 °C (-4...149 °F)											
Temperature, surrounding air, max.	65 °C (149 °F)											
Temperature, non-operating	IEC60068-2-1 (Test Ad, Operating Cold), IEC60068-2-2, (Test Bd, Operating Dry Heat), IEC 60068-2-14 (Test Nb, Operating Thermal Shock): -40...85 °C (-40...185 °F)											
North American temp code	T4											

**Certifications – 2080-SERIALISOL**

<b>Certification (when product is marked)<sup>(1)</sup></b>	<b>Value</b>
c-UL-us	<p>UL Listed Industrial Control Equipment, certified for US and Canada. See UL File E322657.</p> <p>UL Listed for Class I, Division 2 Group A,B,C,D Hazardous Locations, certified for U.S. and Canada. See UL File E334470.</p>
CE	<p>European Union 2004/108/EC EMC Directive, compliant with: EN 61326-1; Meas./Control/Lab., Industrial Requirements EN 61000-6-2; Industrial Immunity EN 61000-6-4; Industrial Emissions EN 61131-2; Programmable Controllers (Clause 8, Zone A &amp; B)</p> <p>European Union 2006/95/EC LVD, compliant with: EN 61131-2; Programmable Controllers (Clause 11)</p>
C-Tick	Australian Radiocommunications Act, compliant with: AS/NZS CISPR 11; Industrial Emissions

(1) See the Product Certification link at <http://www.rockwellautomation.com/products/certification/> Declarations of Conformity, Certificates, and other certification details.

**Notes:**

## Quickstart

This chapter provides the following quickstarts.

Topic	Page
Add and Configure Plug-ins in Connected Components Workbench	79
Browse Your 2080-DNET20 Plug-in Using RSLinx	81
Flash Upgrade Your 2080-DNET20 Plug-in Firmware	84
Quickstart Project for 2080-DNET20 Plug-in	88
Quickstart Projects for 2080-MOT-HSC Plug-in	93

### Add and Configure Plug-ins in Connected Components Workbench

This section shows you an example of how to configure the plug-ins through the Connected Components Workbench software.

**TIP** For more information about using Connected Components Workbench, you can check out the Connected Components Workbench Online Help (it comes with the software).

The following steps show a Micro820 controller.

1. Launch the Connected Components Workbench software and open your Micro800 project. On the Project Organizer pane, right-click the project name and select Open.

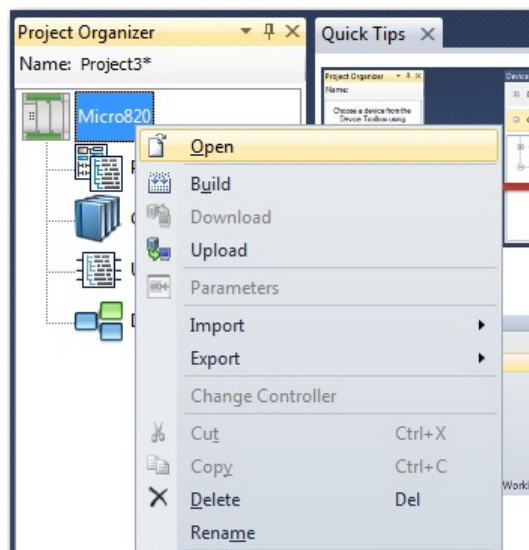

The Controller Properties page appears.

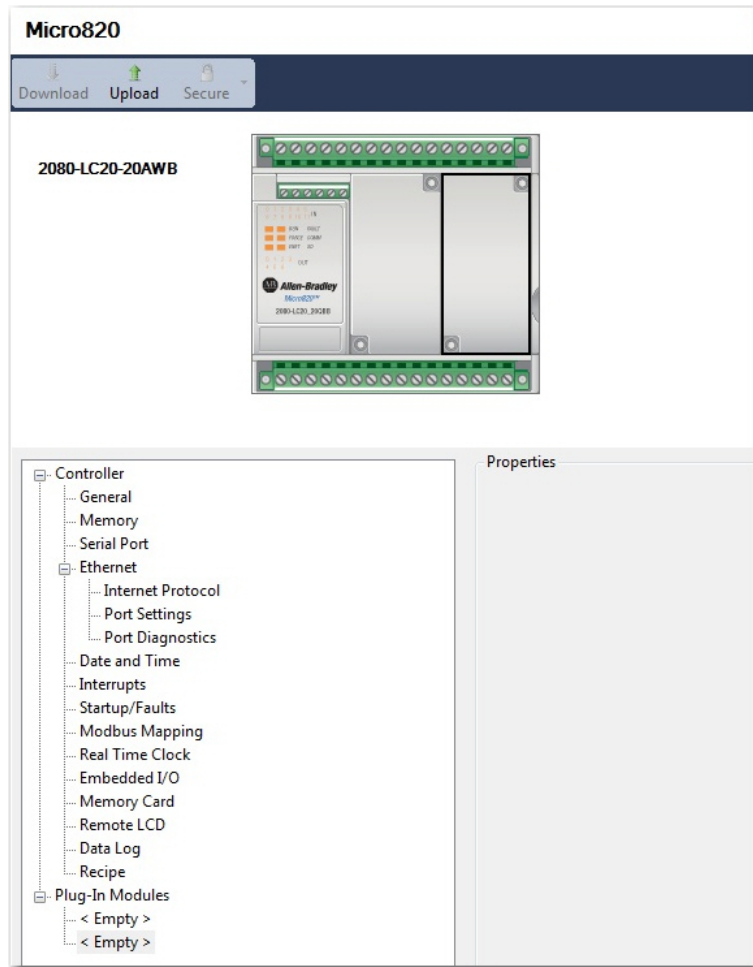

2. To add a Micro800 plug-in, you can do any of the following:
  - Right-click the plug-in slot you would like to configure and choose the plug-in, as shown below.

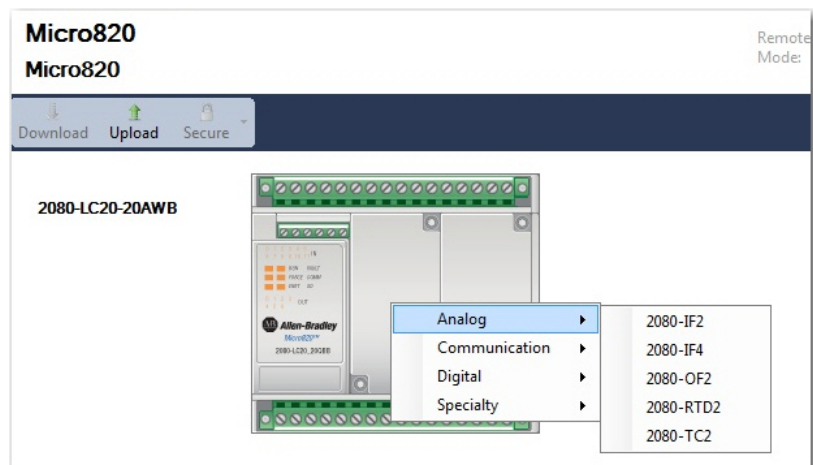



- Right-click the plug-in slot in the Controller Properties tree and choose the plug-in you would like to add.

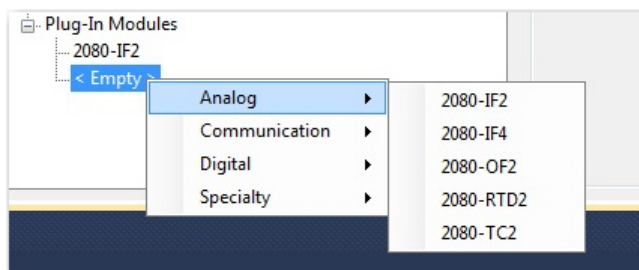

The device configuration window should show the added plug-in modules:

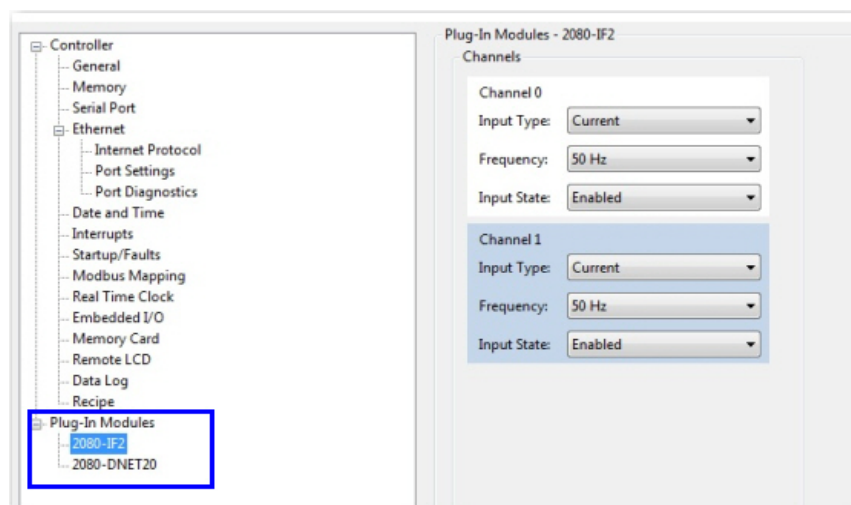

## Browse Your 2080-DNET20 Plug-in Using RSLinx

There are two methods you can use to browse for your 2080-DNET20 plug-in using RSLinx. The first method is browsing directly to the plug-in through the DeviceNet network. The second method is browsing through a Micro820/Micro830/Micro850 controller using the pass through feature. This allows you to upgrade the firmware of the plug-in.

**IMPORTANT** To use the controller pass through feature, the following firmware revisions are required:

- Micro820/Micro830/Micro850 controller firmware revision 8.011 or higher.
- 2080-DNET20 plug-in firmware revision 2.011 or higher.

## Browse Using the DeviceNet Network

From the computer, the 2080-DNET20 plug-in can be browsed through the DeviceNet network. This requires an additional device to connect the computer to the DeviceNet network. For example, you can use the 1788-EN2DN or 1784-U2DN devices. For instructions on connecting the plug-in to the DeviceNet network, see [Setup and Wiring on page 89](#).

### Browsing the 2080-DNET20 plug-in through the DeviceNet network

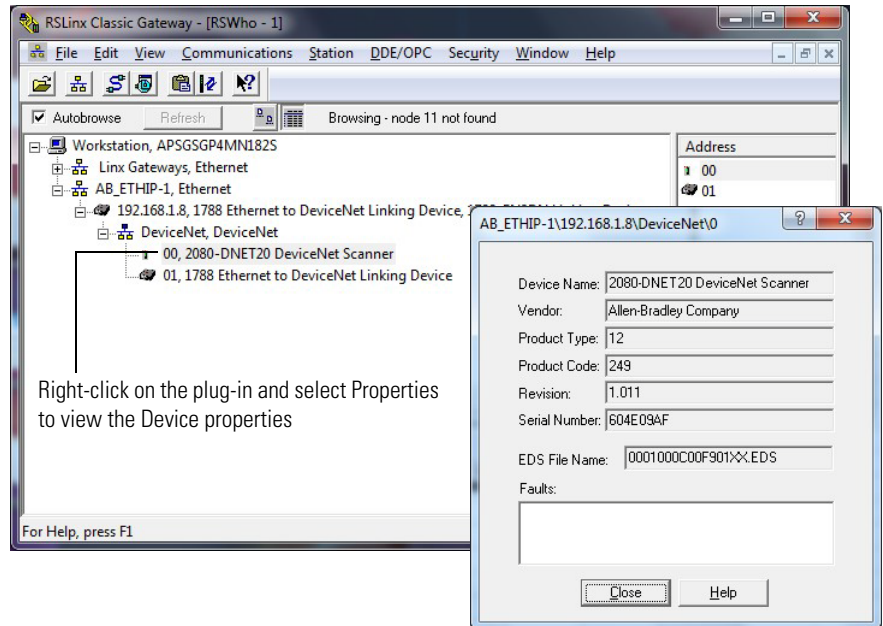

## Browse Using the Micro800 Pass Through

**IMPORTANT** To use the controller pass through feature, the following firmware revisions are required:

- Micro820/Micro830/Micro850 controller firmware revision 8.011 or higher.
- 2080-DNET20 plug-in firmware revision 2.011 or higher.

### Browsing the 2080-DNET20 plug-in from the controller backplane through EtherNet/IP.

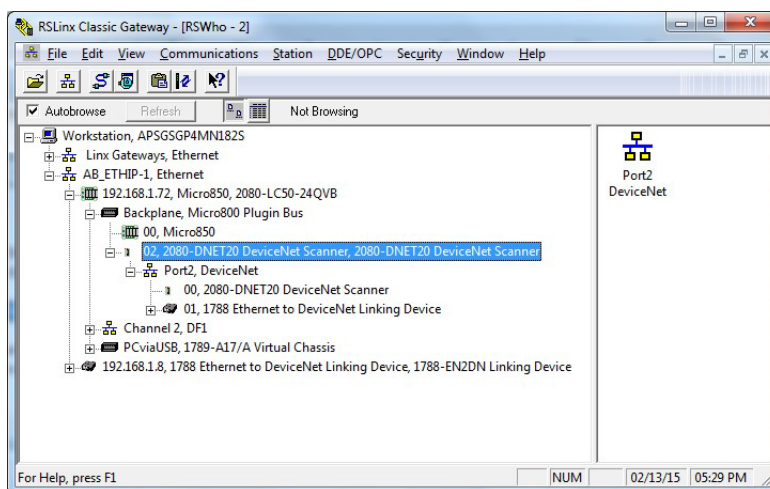

### Browsing the 2080-DNET20 plug-in from the controller backplane through USB.

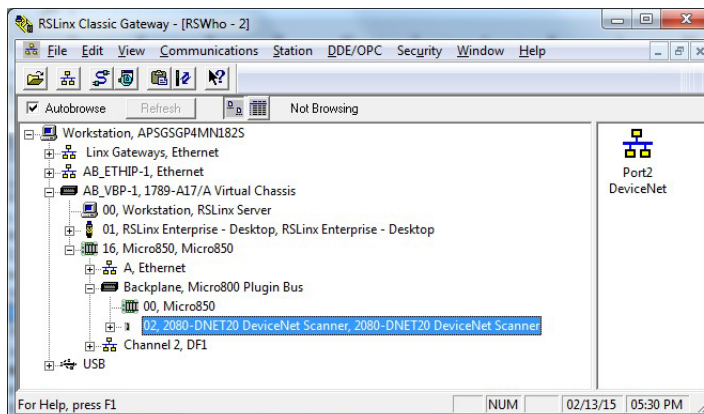

**Browsing the 2080-DNET20 plug-in from the controller backplane through Serial DF1.**

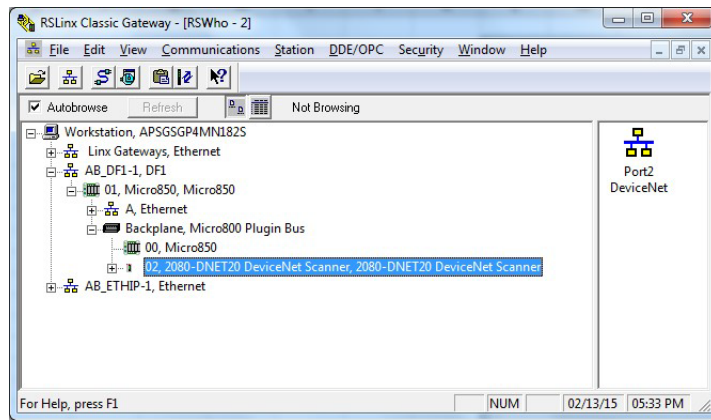

**Flash Upgrade Your 2080-DNET20 Plug-in Firmware**

This quick start will show you how to flash update the firmware in a 2080-DNET20 plug-in using ControlFLASH. ControlFLASH is installed or updated when Connected Components Workbench software is installed on your computer. It is recommended that the controller is in Program mode and the plug-in is in Idle mode when performing the upgrade.

1. Check the firmware revision of the plug-in.  
To do this, check the Device Properties of the plug-in RSLinx.

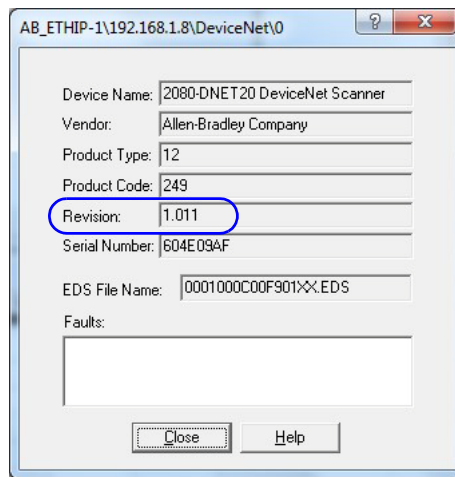

2. Launch ControlFLASH and click Next.



3. In the Catalog Number dialog, select the 2080-DNET20 plug-in and click Next.

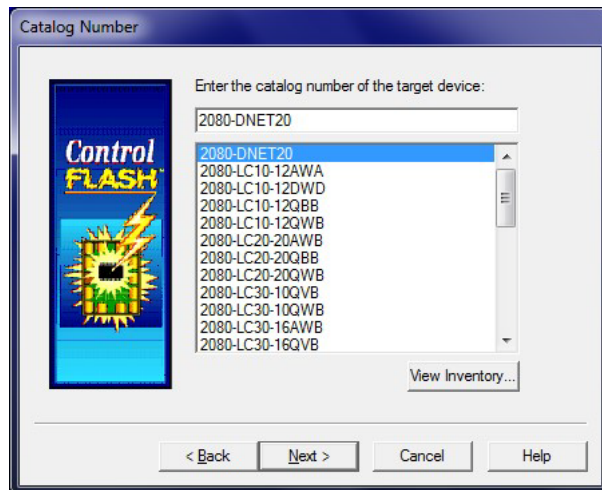

4. The Connection Browser dialog appears, select the 2080-DNET20 plug-in and click OK.

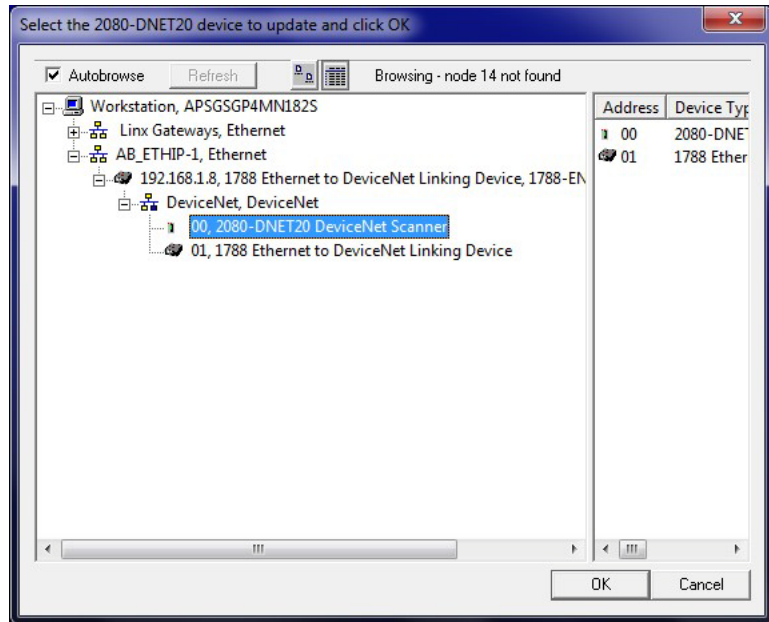

**IMPORTANT** To upgrade from firmware revision 1.012 to 2.011, the DeviceNet network should be used. From revision 2.011 onwards, you can upgrade the firmware using the controller pass through feature.

5. Select the firmware revision to flash and click Next.

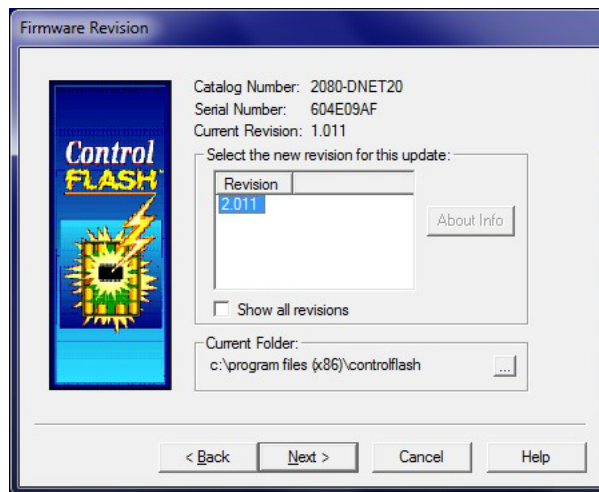

- Verify your selection and click Finish.



- Click Yes to continue.

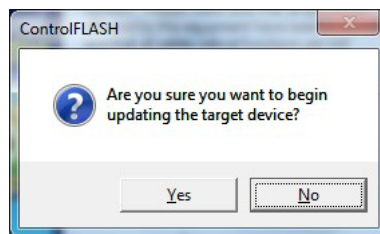

- Click OK to begin the upgrade process.

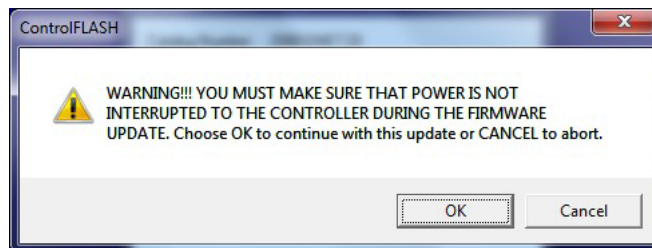

A dialog showing the progress appears.

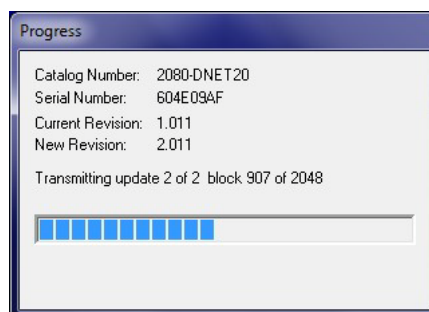



9. When the flash update is complete, the Update Status dialog appears. Check that the status is green and the update is complete. If the status is unsuccessful, power cycle the controller and restart the upgrade process.

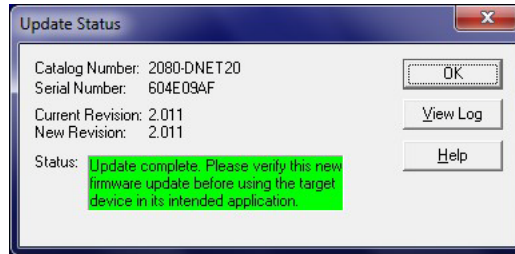

10. After a successful firmware upgrade, power cycle the controller.

## Quickstart Project for 2080-DNET20 Plug-in

Using your 2080-DNET20 plug-in module and user defined function blocks in Connected Components Workbench, the following quickstart project shows you how to turn on all the outputs of a CompactBlock LDX module connected in Node 3.

### IMPORTANT Quickstart Prerequisite

For the following quickstart projects, you first need first need to download the DNET UDFBs and sample project from the Sample Code Library:

<http://www.rockwellautomation.com/go/scmicro800>

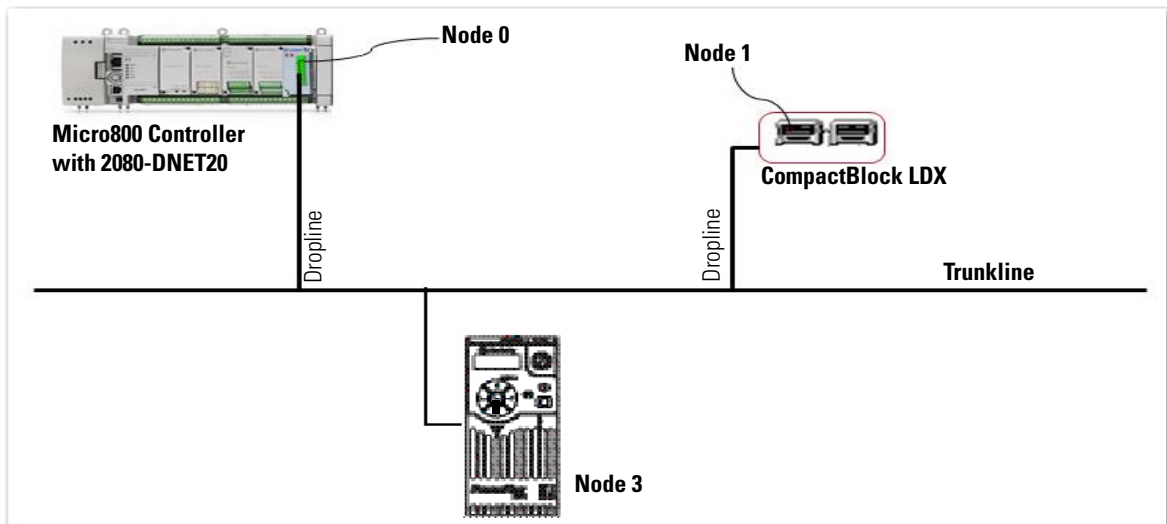



## Setup and Wiring

1. Insert your 2080-DNET20 module into the designated plug-in slot in your Micro800 controller.

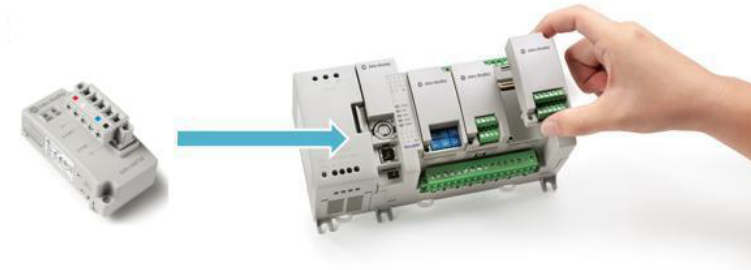

2. Next, wire your 2080-DNET20 plug-in following the diagram shown below.

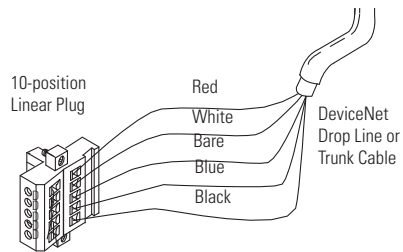
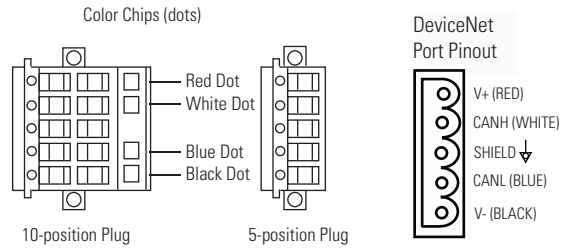

20474

3. Configure the DeviceNet devices as shown below.

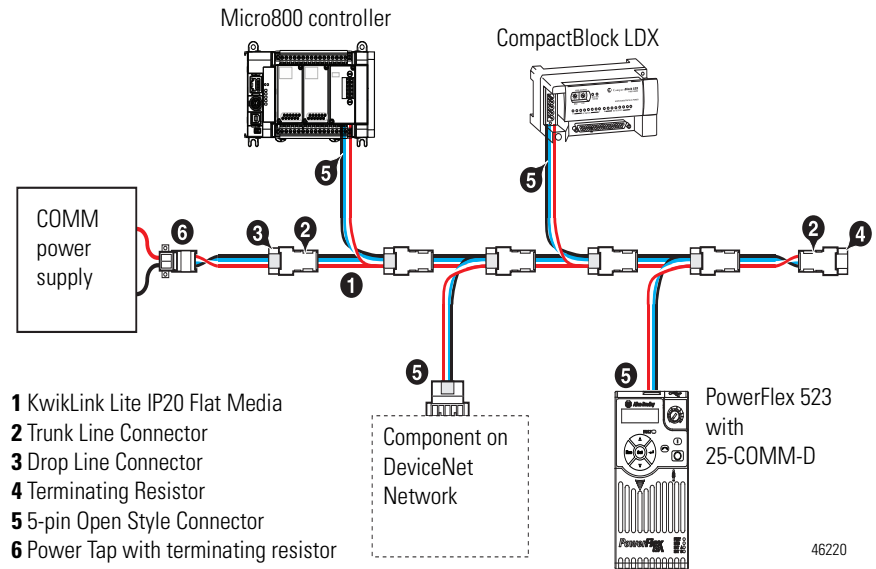

4. Set the node address for the CompactBlock LDX through the node switches to node 1.
5. Set the node address for the PowerFlex drive through the 25-COMM-D to node 2. Set the baud rate to autobaud.

## Configuration



**WARNING:** Do not change the configuration when the Controller is in RUN mode.

1. Launch Connected Components Workbench and open the sample project you have downloaded from the Sample Code Library.
2. Import the following DNET UDFBs into your project:
  - RA\_DNET\_MASTER
  - RA\_DNET\_LDX\_DISCRETE
  - RA\_PF\_DNET\_STANDARD

See [User Defined Function Blocks on page 45](#) for information on input and output parameters for these UDFBs.

3. Configure the RA\_DNET\_MASTER UDFB as shown.

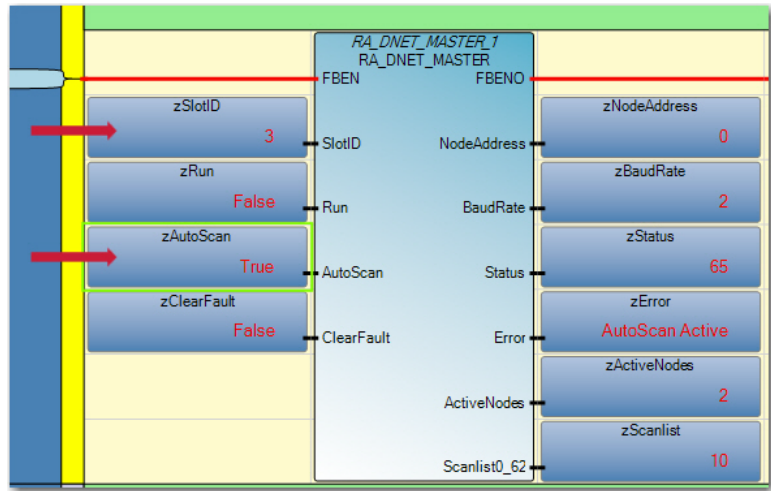

4. Configure the PowerFlex UDFB as shown (that is, set the node address, plug-in slot ID, and so on).

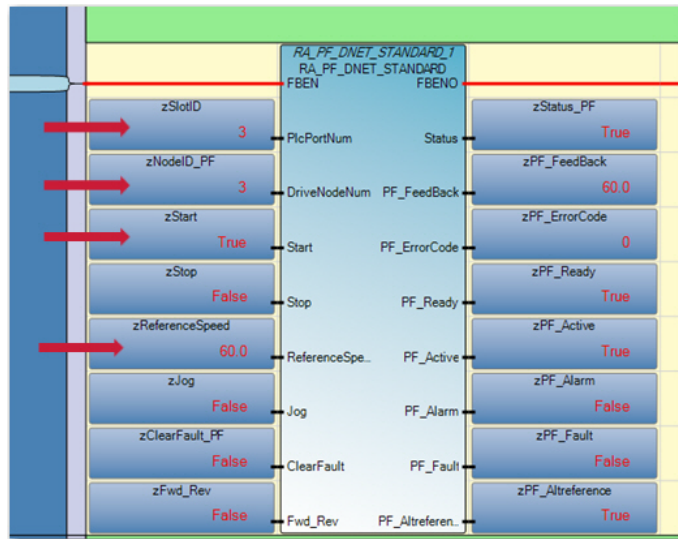

- Configure the CompactBlock LDX UDFB as shown (that is, set the node address, plug-in slot ID, Module1...Module4).

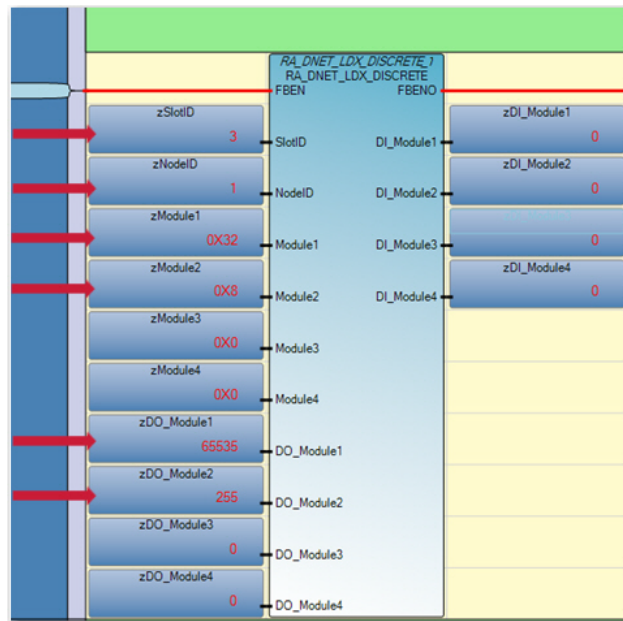

## Build and Download

Build and download the project into the controller.

## Execute Program

1. Set Micro800 controller to RUN mode.
2. Enable AutoScan in the DeviceNet Scanner UDFB.  
This will scan all the active nodes and populate the scan list.

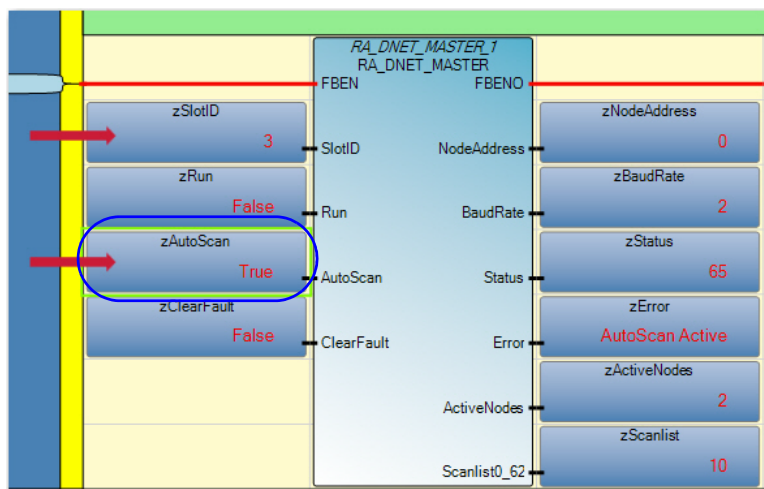

3. Set the Scanner to RUN mode.

---

### IMPORTANT

It is recommended that when Autoscan is running for the nodes in range, or for the connection to be established, the nodes should be idle without any pre-occupied connections requests.

---

## Quickstart Projects for 2080-MOT-HSC Plug-in

The following quickstart projects will show you how to write and use three user-defined function blocks to configure and use your Micro800 High Speed Counter plug-in.

---

### IMPORTANT

#### Quickstart Prerequisite

For the following quickstart projects, you first need to download the HSC UDFBs and sample project from the Sample Code Library:

<http://www.rockwellautomation.com/go/scmicro800>

---

## Setup and Wiring

1. Insert the high speed counter plug-in module into the designated slot in your Micro800 controller.



2. Wire your plug-in to your controller as shown in the following diagram.

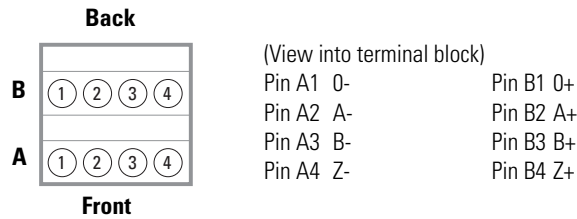

### Sinking Output Wiring

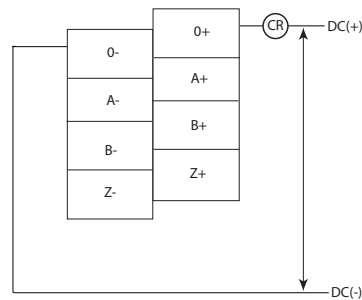

### Sourcing Output Wiring

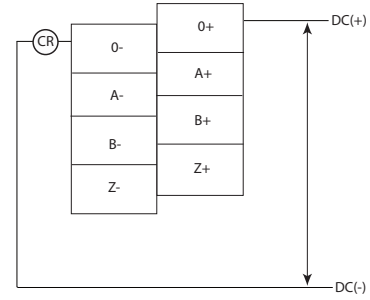

**NOTE:** Output functionality is not currently supported and is dependent on availability of UDFB support.

## Configuration for UDFB 1: RA\_HSCPlugIn

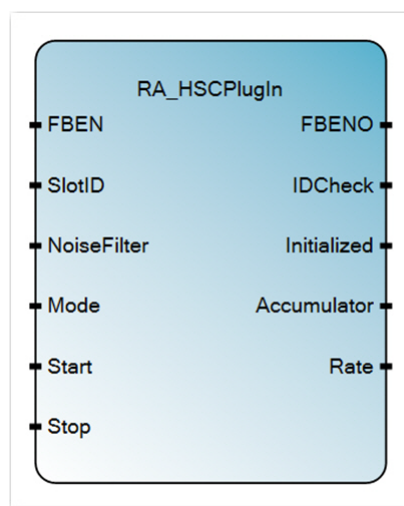

NOTE: The purpose of this UDFB is to get high speed counter accumulator value and current pulse frequency.

1. Launch Connected Components Workbench. Open the sample project you have downloaded from the Sample Code Library.
2. Import the RA\_HSCPlugIn UDFB you have downloaded into this project. Note that the sample project will have the following input and output parameters.

### Input and Output Parameters

Parameter	Type	Data Type	Description
FBEN	INPUT	BOOL	Function block Enable input
SlotID	INPUT	UINT	Plug-in slot number. Slot ID = 1...5 (starting with the far left slot 1)
NoiseFilter	INPUT	USINT	00: No filter 01: 250 kHz 02: 200 kHz 03: 80 kHz 04: 40 kHz 05: 13.3 kHz 06: 10 kHz 07: 4 kHz 08: 2 kHz 09: 1 kHz 10: 500 Hz 11: 250 Hz 12: 125 Hz 13: 63.5 Hz 14: 31.25 Hz
HSCMode	INPUT	USINT	0, 2, 4, 6, 8, 10, 12
Start	INPUT	BOOL	Start counter.
Stop	INPUT	BOOL	Stop the counter and clear "MaxDPos" and "MaxDSpd" value.
FBENO	OUTPUT	BOOL	Function block Enable output
IDCheck	OUTPUT	BOOL	TRUE: HSC plug-in is at selected slot. FALSE: Wrong plug-in or no plug-in at selected slot.

### Input and Output Parameters

Parameter	Type	Data Type	Description
Initialized	OUTPUT	BOOL	TRUE: HSC plug-in initialization finished and ready to execute. FALSE: HSCplug-in initialization not yet finished.
Accumulator	OUTPUT	LINT	Accumulator value.
Rate	OUTPUT	Real	Current pulse rate. The rate calculation is based on how many pulses have been counted every 10 ms.

### Build and Download

Build and download the program into the controller.

### Execute the Function Block

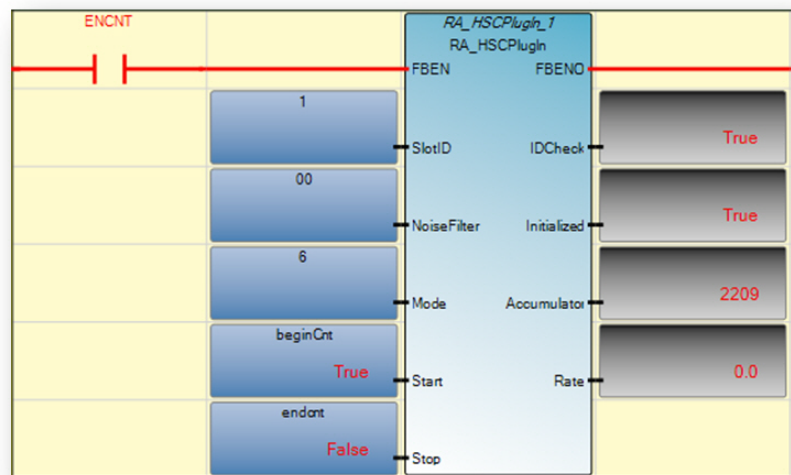

#### Operation Sequence for RA\_HSCPlugIn

- A rising edge of FBEN will cause the input Start to initialize steps. When initialization is done, Output Initialized will change to TRUE.
- User can start the feedback process (Start counting) after Initialized output becomes TRUE. A rising edge of Start will trigger the feedback process. Note that if the user wants to know the positioning information the user needs to do the following steps to make sure position information is in sync:
  - Initialize the RA\_HSCPlugIn function block
  - Start the counting process when necessary
- User can stop/pause the process by giving a rising edge of Stop. If you want to disable the function block, set Stop to true first.



- If FBEN is True and the user starts the feedback process from previous Stop state, the function block will not be reinitialized. It will resume count from previous accumulator value.
- IF FBEN is False, then all outputs are cleared and accumulator is cleared. When FBEN goes True again, the HSC will be reinitialized.

## Configuration for UDFB 2: RA\_EncoderFDBK

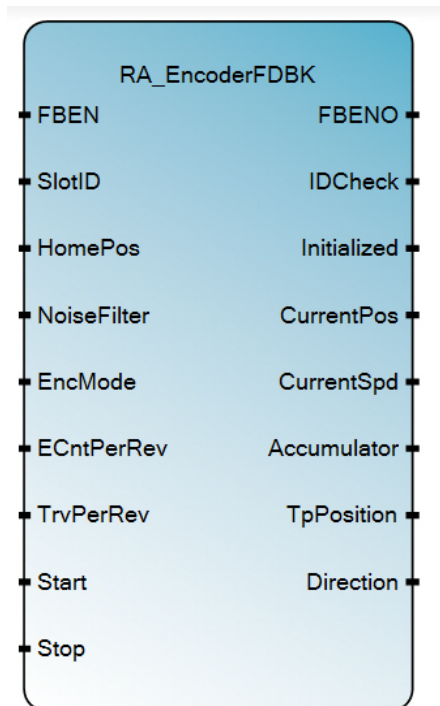

NOTE: This UDFB will get the positioning information of a motion axis based on pulses counted from the encoder.

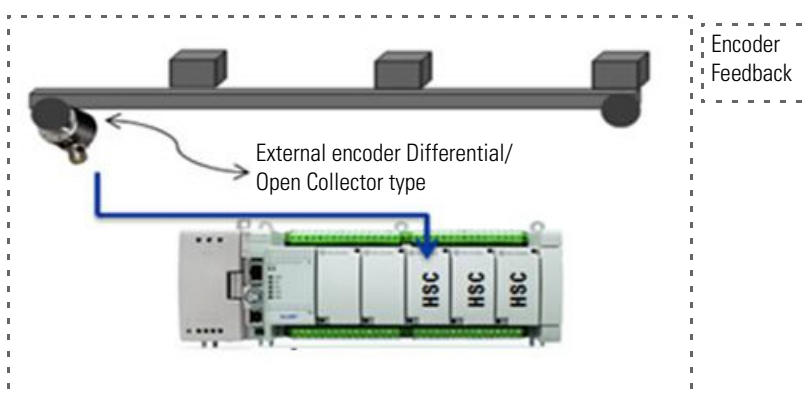

1. Launch Connected Components Workbench and open the HSC project you have downloaded from the Sample Code Library.
2. Import the downloaded RA\_EncoderFDBK into this project.  
Note that the UDFB comes with the following input and output variables.

### Input and Output Parameters

Parameter	Type	Data Type	Description
FBEN	INPUT	BOOL	Function block Enable input
SlotID	INPUT	UINT	Plug-in slot number. Slot ID = 1...5 (starting with the far left slot 1)
HomePos	INPUT	REAL	Home position. Same value indicated in MC_Home instruction.

### Input and Output Parameters

Parameter	Type	Data Type	Description
NoiseFilter	INPUT	USINT	00 - No filter 01 - 250 kHz 02 - 200 kHz 03 - 80 kHz 04 - 40 kHz 05 - 13.3 kHz 06 - 10 kHz 07 - 4 kHz 08 - 2 kHz 09 - 1 kHz 10 - 500 Hz 11 - 250 Hz 12 - 125 Hz 13 - 62.5 Hz 14 - 31.25 Hz
EncMode	INPUT	USINT	Encoder Mode. 1-X1, 2- X2, 4-X4.
ECntPerRev	INPUT	REAL	User input to indicate how many X1 counts will be generated when Encoder disk turns one revolution.
TrvPerRev	INPUT	REAL	The actual distance travelled when motor turns one revolution.
Start	INPUT	BOOL	Start counter.
Stop	INPUT	BOOL	Stop the counter and clear MaxDPos and MaxDSpd value
FBENO	OUTPUT	BOOL	Function block enable output.
IDCheck	OUTPUT	BOOL	TRUE: HSC plug-in is at selected slot. FALSE: Wrong plug-in or no plug-in at selected slot.
Initialized	OUTPUT	BOOL	TRUE: Indicates HSC initialization has finished. FALSE: Indicates HSC initialization has not finished.
CurrentPos	OUTPUT	REAL	Current position.
CurrentSpd	OUTPUT	REAL	Current speed (Unit = user distance per second).
Accumulator	OUTPUT	LINT	Accumulator value.
TpPosition	OUTPUT	REAL	Position recorded when the latest touch probe is triggered.
Direction	OUTPUT	SINT	1 = Forward -1 = Reverse 0 = Not moving

### Build and Download

Build and download the program into the controller.

## Execute the Function Block

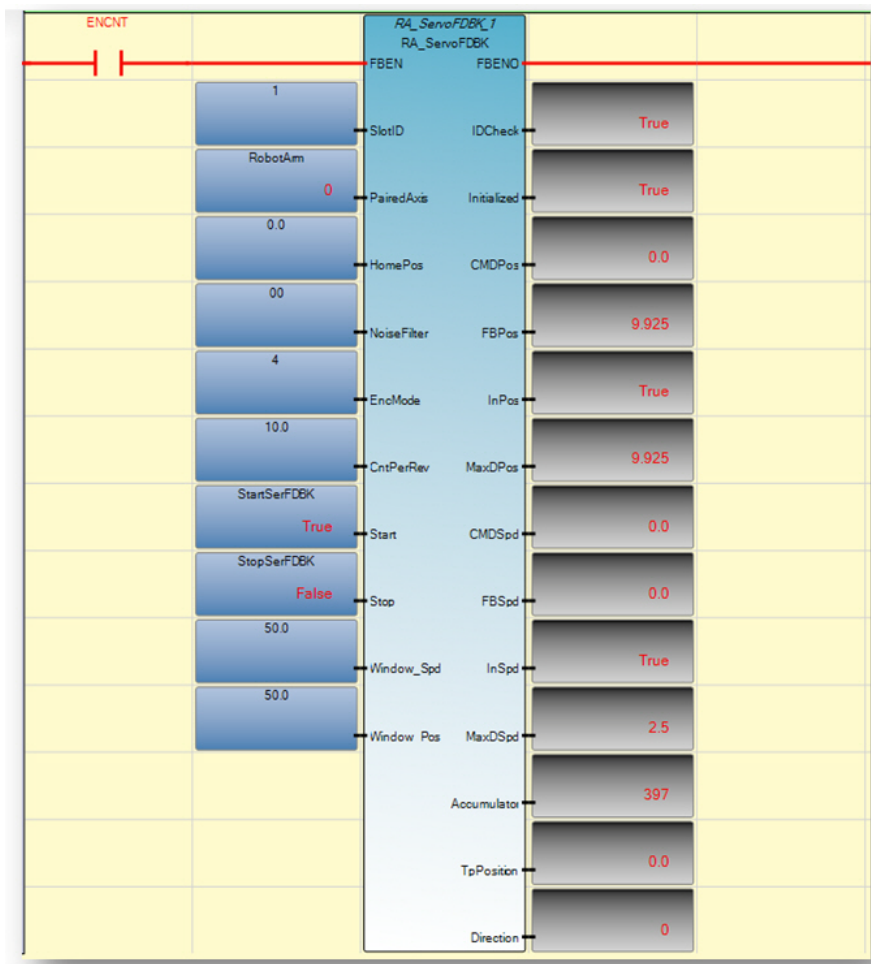

### Operation Sequence

- A rising edge of FBEN will cause the function block Start initialize steps. When initialized done, Output Initialized will change to TRUE.
- You can start the feedback process (Start counting) after Initialized output becomes TRUE. A rising edge of Start will trigger the feedback process. Note that if you want to know the positioning information, you need to do the following to make sure position information is in sync:
  - a. Initialize the RA\_FDBKAxis function block.
  - b. Home the PTO axis to be monitored.
  - c. Once home is done, start the feedback process.
- You can stop/pause the process and clear the MaxDPos and MaxDSpd by given a rising edge of Stop. To disable the function block, you first need to set Stop to false.
- If FBEN is True and you start the feedback process from previous Stop state, the function block will not be reinitialized. Count will resume from previous accumulator value.

- IF FBEN is False, then all outputs are cleared and accumulator is cleared and when FBEN goes true again, the HSC will be reinitialized.

### Configuration for HSC UDFB 3: RA\_ServoFDBK

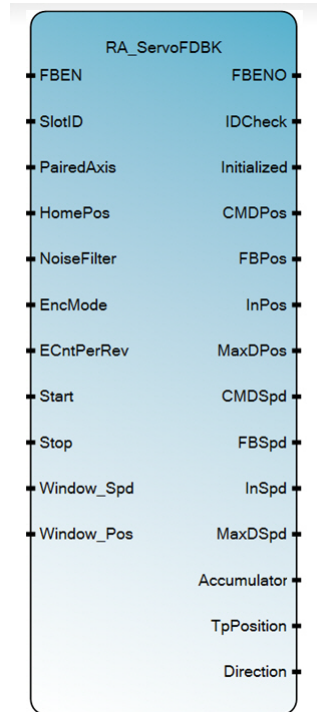

NOTE: This UDFB gets positioning information of a PTO axis that is controlled by a Micro800 controller with HSC plug-in installed.

1. Launch Connected Components Workbench and open the sample project you have just downloaded from the Sample Code Library.
2. Import the RA\_ServoFDBK UDFB into this project.  
Note that the UDFB comes with the following input and output variables.

#### Input and Output Parameters

Parameter	Type	Data Type	Description
FBEN	INPUT	BOOL	Function block Enable input
SlotID	INPUT	UINT	Plug-in slot number. Slot ID = 1...5 (starting with the far left slot 1)
HomePos	INPUT	REAL	Home position. Same value indicated in MC_Home instruction.

**Input and Output Parameters**

<b>Parameter</b>	<b>Type</b>	<b>Data Type</b>	<b>Description</b>
NoiseFilter	INPUT	USINT	00 - No filter 01 - 250 kHz 02 - 200 kHz 03 - 80 kHz 04 - 40 kHz 05 - 13.3 kHz 06 - 10 kHz 07 - 4 kHz 08 - 2 kHz 09 - 1 kHz 10 - 500 Hz 11 - 250 Hz 12 - 125 Hz 13 - 62.5 Hz 14 - 31.25 Hz
EncMode	INPUT	USINT	Encoder Mode. 1-X1, 2- X2, 4-X4.
ECntPerRev	INPUT	REAL	User input to indicate how many X1 counts will be generated when Encoder disk turns one revolution.
TrvPerRev	INPUT	REAL	The actual distance travelled when motor turns one revolution.
Start	INPUT	BOOL	Start counter.
Stop	INPUT	BOOL	Stop the counter and clear MaxDPos and MaxDSpd value
FBENO	OUTPUT	BOOL	Function block enable output.
IDCheck	OUTPUT	BOOL	TRUE: HSC plug-in is at selected slot. FALSE: Wrong plug-in or no plug-in at selected slot.
Initialized	OUTPUT	BOOL	TRUE: Indicates HSC initialization has finished. FALSE: Indicates HSC initialization has not finished.
CurrentPos	OUTPUT	REAL	Current position.
CurrentSpd	OUTPUT	REAL	Current speed (Unit = user distance per second).
Accumulator	OUTPUT	LINT	Accumulator value.
TpPosition	OUTPUT	REAL	Position recorded when the latest touch probe is triggered.
Direction	OUTPUT	SINT	1 = Forward -1 = Reverse 0 = Not moving

**Build and Download**

Build and download the program into the controller.

## Execute the Function Block

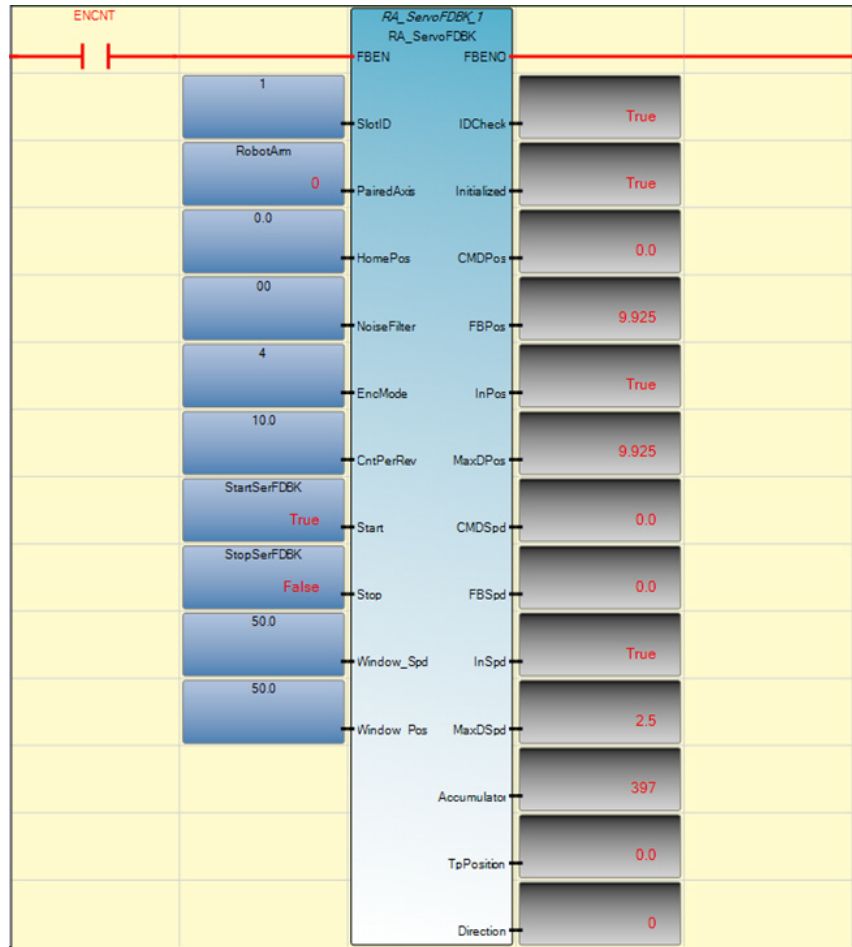

### Operation Sequence

- A rising edge of FBEN causes the function block to start initializing steps. When Initialized is done, Output Initialized changes to TRUE.
- You can start the feedback process (Start counting) after Initialized is TRUE. A rising edge of Start will trigger the feedback process. Please note that if you want to get positioning information, you need to do following steps to ensure that position information is in sync:
  - a. Initialize the RA\_FDBKAxis function block.
  - b. Home the PTO axis to be monitored.
  - c. Once home is done, start the feedback process.
- You can stop/pause the process and clear the MaxDPos and MaxDSpd by giving a rising edge of Stop. If you want to disable the function block, you need set it to Stop state first.
- If FBEN is True and you start the feedback process from previous Stop state, the function block will not be re-initialized. It will resume count from previous accumulator value.

- IF FBEN is false, then all outputs are cleared and accumulator is cleared. When FBEN goes true again, the HSC will be re-initialized.

**Notes:**



## Error Codes

### Troubleshooting

For troubleshooting your Micro800 controller system, see the User Manual for your controller:

- Micro830 and Micro850 Programmable Controllers User Manual, publication [2080-UM002](#).
- Micro820 Programmable Controllers User Manual, publication [2080-UM005](#).

### Error Codes for Micro800 Plug-ins

This section lists possible error codes for your plug-in modules, as well as recommended actions for recovery.

If an error persists after performing the recommended action, contact your local Rockwell Automation technical support representative. For contact information, go to <http://support.rockwellautomation.com/MySupport.asp>

#### List of Error Codes for Micro800 Plug-ins

Error Code	Description	Recommended Action
For the following four error codes, <b>z</b> refers to the slot number of the plug-in module. If <b>z</b> = 0, then the slot number cannot be identified		
0xF0Az	The plug-in I/O module has encountered an error during operation.	Perform one of the following: <ul style="list-style-type: none"> <li>• Check the condition and operation of the plug-in I/O module.</li> <li>• Cycle power to the Micro800 controller.</li> </ul>
0xF0Bz	The plug-in I/O module configuration does not match the actual I/O configuration detected.	Perform one of the following: <ul style="list-style-type: none"> <li>• Correct the plug-in I/O module configuration in the user program to match that of the actual hardware configuration.</li> <li>• Check the condition and operation of the plug-in I/O module.</li> <li>• Cycle power to the Micro800 controller.</li> <li>• Replace the plug-in I/O module.</li> </ul>
0xF0Dz	A hardware error has occurred while power was being applied to the plug-in module or the plug-in module was removed.	Perform the following: <ul style="list-style-type: none"> <li>• Correct the plug-in I/O module configuration in the user program.</li> <li>• Build and download the program using Connected Components Workbench.</li> <li>• Put the Micro800 controller into Run mode.</li> </ul>
0xF0Ez	The plug-in I/O module configuration does not match the actual I/O configuration detected.	Perform the following: <ul style="list-style-type: none"> <li>• Correct the plug-in I/O module configuration in the user program.</li> <li>• Build and download the program using Connected Components Workbench.</li> <li>• Put the Micro800 controller into Run mode.</li> </ul>

## Calling Rockwell Automation for Assistance

If you need to contact Rockwell Automation or local distributor for assistance, it is helpful to obtain the following (prior to calling):

- controller type, series letter, revision letter, and firmware (FRN) number of the controller
- controller indicator status

## Numerics

**2080-DNET20** 5  
 certifications 76  
 specifications 73  
 wiring 11

**2080-IF2** 3  
 certifications 66  
 specifications 64  
 wiring 8

**2080-IF4** 3  
 certifications 66  
 specifications 64  
 wiring 8

**2080-IQ4** 2  
 certifications 61  
 specifications 59  
 wiring 8

**2080-IQ4OB4** 2  
 certifications 61  
 specifications 59  
 wiring 8

**2080-IQ4OV4** 2  
 certifications 61  
 specifications 59  
 wiring 8

**2080-MEMBAK-RTC** 3, 7  
 specifications 66

**2080-MOT-HSC** 4  
 certifications 73  
 specifications 69  
 temperature derating 70  
 wiring 9

**2080-OB4** 2  
 certifications 61  
 specifications 59  
 wiring 8

**2080-OF2** 3  
 certifications 66  
 specifications 64  
 wiring 9

**2080-OV4** 2  
 certifications 61  
 specifications 59  
 wiring 8

**2080-OW4I** 3  
 certifications 63  
 relay contact ratings 62  
 specifications 61  
 wiring 8

**2080-RTD2** 3, 19, 20  
 certification 66, 67, 68  
 certifications 68  
 data maps 22  
 specifications 67  
 wiring 8

**2080-SERIALISOL** 4  
 certifications 77  
 specifications 76  
 wiring 9

**2080-TC2** 3, 12, 19  
 certifications 66, 67, 68  
 data maps 22  
 features 19  
 specifications 67  
 thermocouple sensor types and ranges 19  
 wiring 8

**2080-TRIMPOT6** 4  
 certifications 67  
 specifications 67

## A

**About Plug-In Modules and Accessories** 19

**Additional Resources** iii

## C

**cable pinout**

controller to modem cable 10

**calibration error bit (CE)** 22

**calling for assistance** 106

**channel temperature data** 22

**CJC open-circuit bit (COC)** 22

**CJC Sensor** 12

**CJC thermistor** 12

**code calibrated bit** 22

**Connected Components Workbench** iv, 19, 20, 21, 22, 23

## D

**data illegal (DI)** 22

## E

**error codes** 105

## H

**hardware features** 7

## I

**installation** 7

## M

### Micro800 plug-ins 1

- 6-channel trimpot analog input plug-in module 4
- DeviceNet scanner plug-in module 5
- digital I/O plug-in module 2
- high speed counter plug-in module 4
- memory backup and high accuracy RTC plug-in module 3
- non-isolated RTD plug-in module 3
- non-isolated unipolar analog I/O plug-in module 3
- relay output plug-in module 3
- RS232/RS485 isolated serial port plug-in module 4

## O

- open circuit** 22
- open-circuit** 19
- overrange** 19, 21, 22

## P

- plug-in modules** 7

## R

- Removal and Insertion Under Power** 19
- RS-232 cable** 10
- RTD** 19, 23
  - sensor types 20, 21

## S

- specifications**
  - analog plug-in modules 64
  - communication plug-in modules 73
  - specialty plug-in modules 66
- system overrange bit (SOR)** 22
- system underrange bit (SUR)** 22

## T

- temperature conversion** 23
- thermistor** 19
- thermocouple** 19, 23
- thermocouple sensor types** 20

## U

- underrange** 19, 21, 22

## W

- wiring** 7



# Rockwell Automation Support

Rockwell Automation provides technical information on the Web to assist you in using its products.

At <http://www.rockwellautomation.com/support/>, you can find technical manuals, a knowledge base of FAQs, technical and application notes, sample code and links to software service packs, and a MySupport feature that you can customize to make the best use of these tools.

For an additional level of technical phone support for installation, configuration, and troubleshooting, we offer TechConnect support programs. For more information, contact your local distributor or Rockwell Automation representative, or visit <http://www.rockwellautomation.com/support/>.

## Installation Assistance

If you experience a problem within the first 24 hours of installation, review the information that is contained in this manual. You can contact Customer Support for initial help in getting your product up and running.

United States or Canada	1.440.646.3434
Outside United States or Canada	Use the <a href="#">Worldwide Locator</a> at <a href="http://www.rockwellautomation.com/support/americas/phone_en.html">http://www.rockwellautomation.com/support/americas/phone_en.html</a> , or contact your local Rockwell Automation representative.

## New Product Satisfaction Return

Rockwell Automation tests all of its products to ensure that they are fully operational when shipped from the manufacturing facility. However, if your product is not functioning and needs to be returned, follow these procedures.

United States	Contact your distributor. You must provide a Customer Support case number (call the phone number above to obtain one) to your distributor to complete the return process.
Outside United States	Please contact your local Rockwell Automation representative for the return procedure.

## Documentation Feedback

Your comments will help us serve your documentation needs better. If you have any suggestions on how to improve this document, complete this form, publication [RA-DU002](#), available at <http://www.rockwellautomation.com/literature/>.

Rockwell Otomasyon Ticaret A.Ş., Kar Plaza İş Merkezi E Blok Kat:6 34752 İçerenköy, İstanbul, Tel: +90 (216) 5698400

**[www.rockwellautomation.com](http://www.rockwellautomation.com)**

### Power, Control and Information Solutions Headquarters

Americas: Rockwell Automation, 1201 South Second Street, Milwaukee, WI 53204-2496 USA, Tel: (1) 414.382.2000, Fax: (1) 414.382.4444

Europe/Middle East/Africa: Rockwell Automation NV, Pegasus Park, De Kleetlaan 12a, 1831 Diegem, Belgium, Tel: (32) 2 663 0600, Fax: (32) 2 663 0640

Asia Pacific: Rockwell Automation, Level 14, Core F, Cyberport 3, 100 Cyberport Road, Hong Kong, Tel: (852) 2887 4788, Fax: (852) 2508 1846

Rockwell Automation Publication 2080-UM004C-EN-E - March 2015

Supersedes Publication 2080-UM004B-EN-E - December 2013

Copyright © 2015 Rockwell Automation, Inc. All rights reserved.