

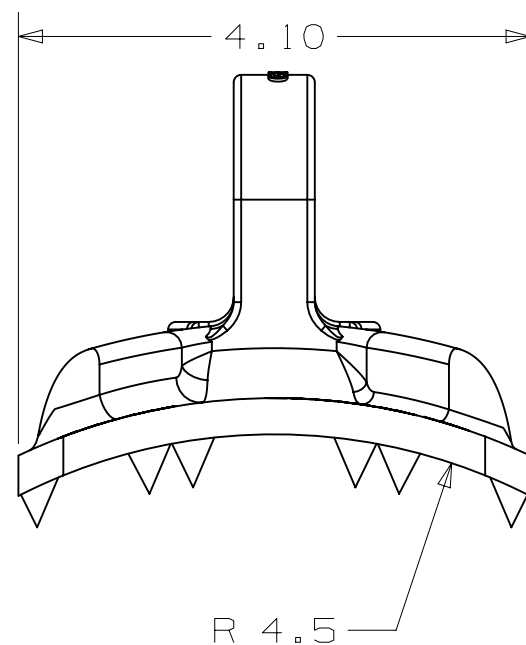

-NOTES-

1. MATERIAL: DUCTILE IRON PER ASTM A536.
2. FINISH: HOT DIP GALVANIZE PER ASTM A153.

| CATALOG NUMBER | FEATURE |
|----------------|-----------|
| GEP6 | CLEATS |
| GEP6N | NO CLEATS |

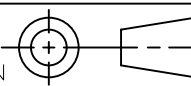
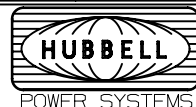

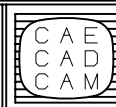
| | | | | |
|---|----------|---|---|--|
| LATEST EC NO: | REV. | DATE | CHANGED BY | RESP ENGINEER |
| --- | C | 11/28/12 | BERGER | --- |
| | | | DO NOT SCALE THIS DWG | THIRD ANGLE PROJECTION  |
| | | | ISO DUAL DIMENSIONS IN=INCH, MM=MILLIMETER | |
| DRN BY: | DATE | TITLE: | | SIZE |
| WILSON | 11/12/12 | POLE EYE PLATE | | B |
|  | |  | |  DWG NO: SAGEP6 |

CONFIDENTIAL: THIS DRAWING AND ITS CONTENTS ARE CONFIDENTIAL AND THE EXCLUSIVE PROPERTY OF HUBBELL POWER SYSTEMS, INC. NO PUBLICATION, DISTRIBUTION OR COPIES MAY BE MADE WITHOUT WRITTEN CONSENT BY HUBBELL POWER SYSTEMS, INC. © 2012 HUBBELL POWER SYSTEMS. UNPUBLISHED, ALL RIGHTS RESERVED UNDER THE COPYRIGHT LAWS