

EU - TYPE EXAMINATION CERTIFICATE

Equipment or Protective System Intended for use in Potentially Explosive Atmospheres Directive 2014/34/EU

- 1 EU - Type Examination Certificate Number: **SGS20ATEX0050X – Issue 2**
- 2 Product: **QTVR Range of Self-Regulating Trace Heating Systems**
- 3 Manufacturer: **nVent Thermal LLC**
- 4 Address: **899 Broadway Street, CA, 94063-3104, United States of America**
- 5 This re-issued certificate extends EU Type Examination Certificate No. **SGS20ATEX0050X** to apply to product designed and constructed in accordance with the specification set out in the Schedule of the said certificate but having any variations specified in the Schedule attached to this certificate and the documents therein referred to.
- 6 SGS Fimko Oy, Notified Body number 0598, in accordance with Article 17 of Directive 2014/34/EU of the European Parliament and of the Council, dated 26 February 2014, certifies that this product has been found to comply with the Essential Health and Safety Requirements relating to the design and construction of products intended for use in potentially explosive atmospheres given in Annex II to the Directive.
- 7 The examination and test results are recorded in confidential Report No. See Certificate History
- 8 Compliance with the Essential Health and Safety Requirements has been assured by compliance with:
**EN IEC 60079-0:2018 EN IEC 60079-7:2015+A1:2018 EN IEC 60079-18:2015+A1:2017
EN 60079-30-1:2017 EN 60079-31:2014**
- 9 in respect of those requirements listed at item 18 of the Schedule.
- 10 If the sign “X” is placed after the certificate number, it indicates that the product is subject to the Specific Conditions of Use specified in the schedule to this certificate.
- 11 This EU - TYPE EXAMINATION CERTIFICATE relates only to the design and construction of the specified product. Further requirements of the Directive apply to the manufacturing process and supply of this product. These are not covered by this certificate.
- 12 The marking of the product shall include the following :
- ⊕ II 2 GD Ex 60079-30-1 eb IIC T4 Gb or Ex 60079-30-1 eb mb IIC T4 Gb T_{min} -60°C
Ex 60079-30-1 tb IIIC T130°C or Ex 60079-30-1 mb tb IIIC T130°C Db**

SGS Fimko Oy Customer Reference No. **865**

Project File No. **21/0234**

This document is issued by the Company subject to their General Conditions for Certification Services accessible at <http://www.sgs.com/en/Terms-and-Conditions.aspx>. Attention is drawn to the limitation of liability, indemnification and jurisdiction issues defined therein. Any holder of this document is advised that information contained herein reflects the Company's findings at the time of their intervention only and within the limits of Client's instructions, if any. It does not necessarily indicate that the equipment may be used in particular industries or circumstances. The Company's sole responsibility is to its Client and this document does not exonerate parties to a transaction from exercising all their rights and obligations under the transaction documents. This document cannot be reproduced except in full, schedule included, without prior written approval of the Company. Any unauthorized alteration, forgery or falsification of the content or appearance of this document is unlawful and offenders may be prosecuted to the fullest extent of the law.

SGS Fimko Oy

Takomotie 8
FI-00380 Helsinki, Finland
Telephone +358 (0)9 696 361
e-mail sgs.fimko@sgs.com
web site www.sgs.fi

Business ID 0978538-5 Member of the SGS Group (SGA SA)



Tuomas Hänninen
SGS Fimko Oy

13

Schedule

14

Certificate Number SGS20ATEX0050X – Issue 2

15 Description of Product

The QTVR Range of Self-Regulating Trace Heating Systems is of the parallel circuit self-regulating type, rated at up to 277V, with power output up to 66W/m (20W/ft). The units have a maximum self-limiting temperature of 130°C. The systems are also suitable for applications at lower temperatures when used as part of a stabilised design. The limiting temperatures of the end seals, splices and power connections must be observed as part of the self-limiting or stabilised design.

Each trace heating system comprises:

- the active heating cable.
- an end seal for terminating the remote end of the unit.
- a cable gland for connecting the powered end of the unit to a suitable terminal enclosure, or alternative integrated power connection systems.

The active heating cable comprises two stranded copper conductors around which is extruded a semi-conductive core material. This core material increases in resistance with increasing temperature and gives the cable its self-limiting property. This semi conductive core with embedded conductors forms the active part of the heating cable. An extruded layer of fluoropolymer serves to insulate the semi conductive core from the conductive covering, covering the active heater. A protective anti-corrosion fluoropolymer sheath may be extruded over the conductive covering.

The declared maximum withstand temperature for the range is 135°C and the minimum installation temperature is -60°C.

CABLE ACCESSORIES

END SEALS

The end seals for terminating the remote end of the unit may be the following types:

Types E-100-L or E-100, which are mechanical end seals incorporating an end cap which is filled with silicone grease sealant covered by certificates Sira14ATEX3015X and PTB09ATEX1060U.

Types E-100-L-A or E-100-A, which are mechanical end seals incorporating an end cap which is filled with silicone grease sealant.

A Raychem Type E-20 heat shrink end seal kit.

Type E-150 mechanical end seals, covered by certificate DEKRA20ATEX0011U.

SPLICES AND JOINTS

The following splicing and jointing arrangements are provided:

A Raychem Type S-20 heat shrink splice kit for connecting lengths of active heating cable.

A Raychem T-100 tee connection system, certificate PTB20ATEX1008U, for connecting up to three heater cables.

Type S-150 mechanical splice kit, covered by certificate DEKRA20ATEX0011U.

POWER CONNECTIONS

Power connection may be achieved by the following means:

Connection Type	ATEX Certificate
JBM-100	PTB20ATEX1008U
JBS-100	PTB20ATEX1008U
JBU-100	PTB20ATEX1008U
C-150-E	DEKRA20ATEX0011U
C25-21 Connection Kit	Baseefa16ATEX0037U
C25-100 Connection Kit	Baseefa16ATEX0038U
C25-100-Metal / C3/4-100-Metal / C25-100-Metal-NP / C3/4-100-Metal- NP / C25-100-Metal-SS Kits	Baseefa16ATEX0039U

The C25-100-Metal / C3/4-100-Metal / C25-100-Metal-NP / C3/4-100-Metal-NP / C25-100-Metal-SS Kits include M25 or ¾ NPT gland to Sira01ATEX1270X and core sealer to Baseefa15ATEX0194U.

A number of power levels and voltages, up to the maximum specified, are included in the range. They are identified in the following manner:

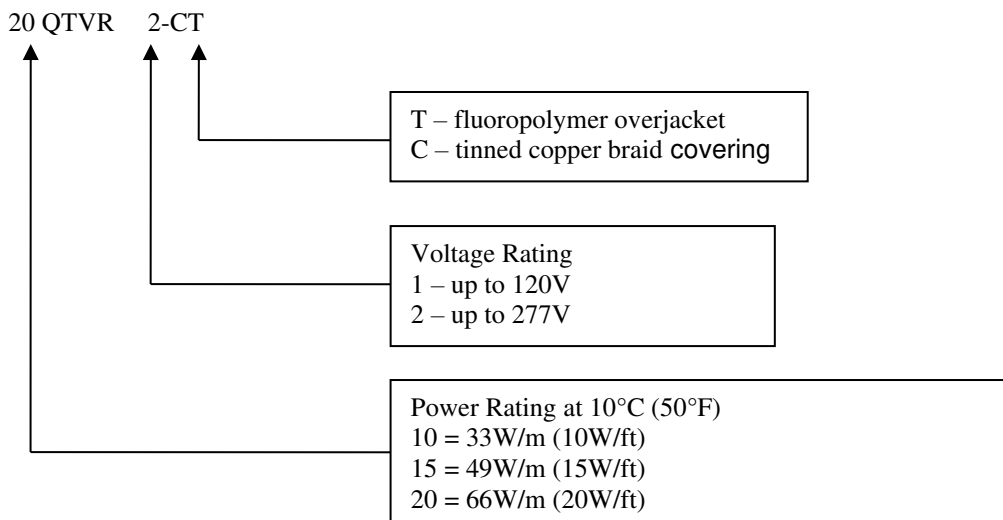

TEMPERATURE CLASS

The self-limiting QTVR trace heating cable has a temperature class of T4.

Any of the products in the range may be considered as part of a stabilised design system. In such a system the design is based upon the use of nVent proprietary software Trace calc Pro. The algorithm defined in this software may be used in additional design software. These designs may carry temperature classes other than the T4 described above and are marked with the actual maximum temperature and the appropriate T class in parenthesis.

The minimum bending radii for QTVR trace heating cable at specific temperatures are shown in the table below:

Temperature, T (°C)	Minimum Bending Radius (mm)
-60 ≤ T < -20	35
-20 ≤ T < -10	30
-10 ≤ T < 0	25
0 ≤ T < +10	20
T ≥ +10	12

16 Report Number

See Certificate History.

17 Specific Conditions of Use

- The following limiting temperature for the end seals and splices shall not be exceeded:
+110°C for the S-20 and E-20
+150°C for the C-150-E, S-150 and E-150
- The end seals, splices and power connections have the following associated ambient temperature ranges:
-60°C to +56°C for the E-20 and S-20
-55°C to +56°C for the T-100, JBM-100, JBS-100, JBU-100 and E-100
-40°C to +56°C for the JBS-100-L, JBM-100-L and JBU-100-L
-55°C to +55°C for the C-150-E, S-150 and E-150
-40°C to +40°C for the E-100-L
-55°C to +110°C for the C25-21 and C25-100
-60°C to +180°C for the C25-100-Metal / C3/4-100-Metal / C25-100-Metal-NP / C3/4-100-Metal-NP / C25-100-Metal-SS
- The assembly of glands, splices and end terminations shall be carried out in accordance with the manufacturer's instructions.
- The heating element supply circuit must include an electrical protection device in conformity with Clause 4.4 of EN 60079-30-1.
- The minimum installation temperature is -60°C. The minimum bending radii at specific temperatures for the Type QTVR units are shown in the table in the equipment description.
- The supply to the heating unit must be terminated in a suitably certified terminal enclosure.
- The minimum installation temperature for E-20 and S-20, end seal and splice is -20°C.
- The installer is to carry out a dielectric strength test on Ex equipment in which the C25-21, C25-100 and C25-100-Metal / C3/4-100-Metal / C25-100-Metal-NP / C3/4-100-Metal-NP / C25-100-Metal-SS connection kit is fitted. No dielectric breakdown shall occur. (Alternatively, an insulation resistance test may be undertaken in accordance with EN 60079-30-2).

18 Essential Health and Safety Requirements

In addition to the Essential Health and Safety Requirements (EHSRs) covered by the standards listed at item 9, the following are considered relevant to this product, and conformity is demonstrated in the report:

Clause	Subject
1.2.7	LVD type requirements
1.2.8	Overloading of equipment (protection relays, etc.)
1.4.1	External effects
1.4.2	Aggressive substances, etc.

19 Drawings and Documents

New drawings submitted for this issue of certificate:

Number	Sheet	Issue	Date	Description
906567 ⁱ	1 of 1	P	05/21/21	C25-21, C25-100 and C25-100-METAL-XX, C3/4-100-METAL-XX Connection Kits

Current drawings which remain unaffected by this issue:

Number	Sheet	Issue	Date	Description
906578-A ⁱⁱⁱ	1 of 1	N	01/15/21	QTVR Heater units (European System)
906794-A ⁱⁱ	1 of 1	AA	03/30/20	Generic ATEX and IECEx Print Dwg for BTV-CT, QTVR-CT, XTV-CT and KTV-CT Heating Cables
950017-A ⁱⁱⁱ	1 of 1	L	3/26/20	QTVR-CT (Narrow/L-Watt)
950018-A ⁱⁱⁱ	1 of 1	H	03/30/20	QTVR-CT (Wide/H-Watt)
9242869 ^{iv}	1 & 2	O	12/09/19	LABL-JBM-100-L-E
9532687 ^{iv}	1 & 2	Q	12/09/19	LABL-JBM-100-L-EP
9621473 ^{iv}	1 & 2	O	12/09/19	LABL-JBS-100-L-E
9777523 ^{iv}	1 & 2	P	12/09/19	LABL-JBS-100-L-EP
9319676 ^{iv}	1 & 2	O	12/09/19	LABL-JBU-100-L-E
9735898 ^{iv}	1 & 2	O	12/09/19	LABL-JBU-100-L-EP
908742-A ^v	1 of 1	A	2/19/20	E-20 Heat Shrinkable End Seal Kit Cut Back Dimensions
908743-A ^{vi}	1 of 1	A	2/19/20	S-20 Heat Shrinkable Splice Joint Kit Cut Back Dimensions

- i) This drawing is common to IECEx BAS 16.0040U, IECEx BAS 16.0041U, IECEx 16.0042U, IECEx BAS 20.0008X, IECEx BAS 20.0009X, IECEx BAS 20.0011X, IECEx BAS 20.0012X, IECEx BAS 20.0013X, IECEx BAS 20.0014X, Baseefa16ATEX0037U, Baseefa16ATEX0038U, Baseefa16ATEX0039U, SGS20ATEX0045X, SGS20ATEX0046X, SGS20ATEX0048X, SGS20ATEX0049X, SGS20ATEX0050X, SGS20ATEX0051X and is held with IECEx BAS 16.0040U.
- ii) These drawings are common to IECEx BAS 20.0008X, IECEx BAS 20.0009X, IECEx BAS 20.0011X, IECEx BAS 20.0012X, IECEx BAS 20.0013X, IECEx BAS 20.0014X, SGS20ATEX0045X, SGS20ATEX0046X, SGS20ATEX0048X, SGS20ATEX0049X, SGS20ATEX0050X, SGS20ATEX0051X and are held with IECEx BAS 20.0008X.
- iii) These drawings are common to IECEx BAS 20.0013X, SGS20ATEX0050X and are held with IECEx BAS 20.0013X.
- iv) These drawings are common to IECEx BAS 20.0008X, IECEx BAS 20.0011X, IECEx BAS 20.0012X, IECEx BAS 20.0013X, IECEx BAS 20.0014X, SGS20ATEX0045X, SGS20ATEX0048X, SGS20ATEX0049X, SGS20ATEX0050X, SGS20ATEX0051X and are held with IECEx BAS 20.0008X.
- v) These drawings are common to IECEx BAS 20.0010X, IECEx BAS 20.0011X, IECEx BAS 20.0013X, SGS20ATEX0047X, SGS20ATEX0048X, SGS20ATEX0050X and are held with IECEx BAS 20.0010X.
- vi) These drawings are common to IECEx BAS 20.0011X, IECEx BAS 20.0013X, SGS20ATEX0048X, SGS20ATEX0050X and are held with IECEx BAS 20.0011X.

20 Certificate History

Certificate No.	Date	Comments
SGS20ATEX0050X	19 October 2020	The release of the prime certificate. The associated test and assessment against the requirements of EN 60079-0:2012+A11:2013, EN IEC 60079-7:2015+A1:2018, EN 60079-18:2015+A1:2017, EN 60079-30-1:2017 and EN 60079-31:2014 is documented in Test Report No. GB/BAS/ExTR20.0031/00.
SGS20ATEX0050X Issue 1	11 February 2021	To assess the QTVR range of self-regulating trace heating systems against EN IEC 60079-0:2018, introduce the low profile power connection, splice and end seal kits, types C-150-E, S-150 and E-150 afforded DEKRA20ATEX0011U, minor amendments to the product description, to change the product name to "QTVR Range of Self-Regulating Trace Heating Systems" and to amend the Specific Conditions of Use. The associated test and assessment is documented in Test Report No. GB/BAS/ExTR21.0006/00.

Certificate No.	Date	Comments
SGS20ATEX0050X Issue 2	7 July 2021	Minor drawing updates not affecting certification. Baseefa Certification Report GB/BAS/ExTR21.0060/00 refers.
For drawings applicable to each issue, see original of that issue.		