

## Adapter Kit for PanelView 5000 and PanelView Plus 7 Performance Terminals

Catalog Numbers 2711P-RAAT7, 2711P-RAAK7, 2711P-RAAT10, 2711P-RAAK10, 2711P-RAAT12, 2711P-RAAT12K, 2711P-RAAT15, 2711P-RAAK15

Topic	Page
Summary of Changes	1
Before You Begin	3
Remove the Existing Terminal From the Panel	4
Drill the Holes for the Adapter Kit	4
Install the Adapter Plate and Backing Plate	6
Prepare to Mount the Terminal	8
Mount the Terminal	9
Finish the Terminal Installation and Apply Power to the Enclosure	11
Drill Template Dimensions	12
Additional Resources	16

## Summary of Changes

This publication contains new and updated information as indicated in the following table.

Topic	Page
Changed PanelView 5500 to PanelView 5000.	1, 2
Added 'Uses Drill Template Cat. No.' column to Adapter Kit Conversion table.	2
Added PanelView 5310 and PanelView 5510 user manual references to step 1.	11
Added PanelView 5310 and PanelView 5510 literature to the Additional Resources table.	16

## About This Adapter Kit

This adapter kit includes an adapter plate, gasket, and backing plate that you install into an existing cutout from a PanelView™ Plus 6 or PanelView standard terminal. Read and understand these instructions before you begin to install the adapter plate kit and terminal.

**IMPORTANT** Do not install a PanelView Plus 7 Standard terminal with this adapter kit. This adapter kit is only for PanelView 5000 and PanelView Plus 7 Performance terminals.

If you install a PanelView Plus 7 Standard terminal into this adapter kit, you can damage the standard terminal bezel. Contaminates can also enter the enclosure and damage components inside the enclosure.

See the [Adapter Kit Conversion Table on page 2](#) to determine the adapter kit for your new and existing terminal.

### Adapter Kit Conversion Table

Adapter Kit Cat. No.	Replace this Existing PanelView Plus 6 or PanelView Standard Terminal...	With this PanelView 5000 or PanelView Plus 7 Performance Terminal	Uses Drill Template Cat. No.
2711P-RAAT7	PanelView Plus 6 700 touch screen	6.5-in. touch screen	
2711P-RAAK7	<ul style="list-style-type: none"> <li>PanelView Plus 6 700 keypad, or keypad with touch screen</li> <li>PanelView Standard 600 keypad, or keypad with touch screen</li> </ul>	6.5-in. keypad with touch screen	<a href="#">VIEW-DS002</a>
2711P-RAAT10	<ul style="list-style-type: none"> <li>PanelView Plus 6 1000 touch screen</li> <li>PanelView Standard 900 touch screen</li> </ul>	10.4-in. touch screen	
2711P-RAAK10	<ul style="list-style-type: none"> <li>PanelView Plus 6 1000 keypad, or keypad with touch screen</li> <li>PanelView Standard 900 keypad</li> </ul>	10.4-in. keypad with touch screen	<a href="#">VIEW-DS003</a>
2711P-RAAT12	<ul style="list-style-type: none"> <li>PanelView Plus 6 1250 touch screen</li> <li>PanelView Standard 1000 touch screen</li> </ul>	12.1-in. touch screen	
2711P-RAAT12K	<ul style="list-style-type: none"> <li>PanelView Plus 6 1250 keypad, or keypad with touch screen</li> <li>PanelView Standard 1000 keypad</li> </ul>	12.1-in. touch screen	<a href="#">VIEW-DS004</a>
2711P-RAAT15	<ul style="list-style-type: none"> <li>PanelView Plus 6 1500 touch screen</li> <li>PanelView Standard 1400 touch screen</li> </ul>	15-in. touch screen	
2711P-RAAK15	<ul style="list-style-type: none"> <li>PanelView Plus 6 1500 keypad, or keypad with touch screen</li> <li>PanelView Standard 1400 keypad</li> </ul>	15-in. keypad with touch screen	<a href="#">VIEW-DS005</a>

## Adapter Kit Contents

The adapter kits include these parts:

- Adapter plate with threaded studs and gasket
- Backing plate
- Mounting clamps
- Mounting nuts (10-32)
- Drill template
- These installation instructions

## Required Tools

These tools are required for installation:

- Clean cloth and a suitable cleanser for dirty panels
- Masking tape and marker or grease pencil
- Scissors
- Center punch and hammer
- Drill and drill bits (pilot drill bit 4.76 mm [3/16 in.], finish drill bit 6.35 mm [1/4 in.])
- Torque wrench and a 3/8-in. socket
- Work gloves

## Before You Begin

---

**IMPORTANT** Before you install this adapter kit and new terminal, read and understand all of these instructions.

---

## Remove the Existing Terminal From the Panel



**ATTENTION:** Remove all power from the components in the enclosure and the existing terminal. Disconnect the communication cables from the terminal.

Failure to remove all power and disconnect communication cables can cause electric shock and unexpected communication signals to the machinery.



**ATTENTION:** Be careful when removing the mounting clamps. The terminals can fall out of the panel after the mounting clamps have been removed. Be sure to hold the terminal in the panel while you remove the mounting clamps, and then carefully remove the terminal from the panel.

Follow these steps to remove the existing terminal from the panel.

1. Remove all power from the enclosure and the terminal.
2. Disconnect all communication cables from the terminal.
3. While holding the terminal, remove the mounting clamps that secure the terminal in the panel.
4. Remove the terminal from the panel.

## Drill the Holes for the Adapter Kit

Follow these steps to drill the holes for the adapter kit by using the drill template included in this kit.

1. Clean the panel where the drill template will be taped over the existing cutout.
2. Determine which side of the drill template that you need.

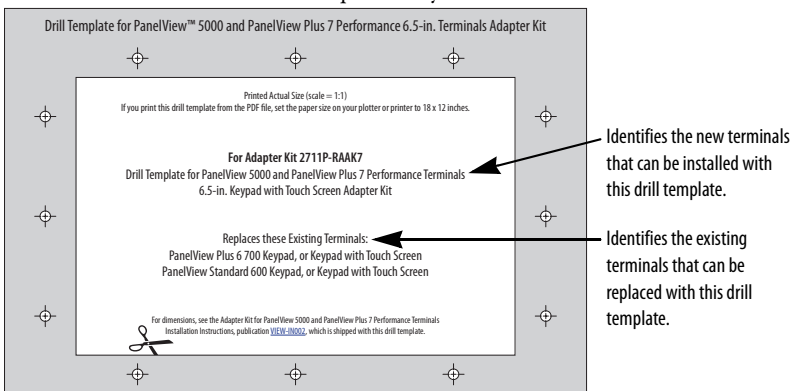

- Cut out the center white space and the white edges of the drill template, and leave the shaded part of the template that includes the drill locations.
- Center the drill template over the existing cutout in the panel.  
Align the edge of the existing panel cutout with the interior edge of the drill template.

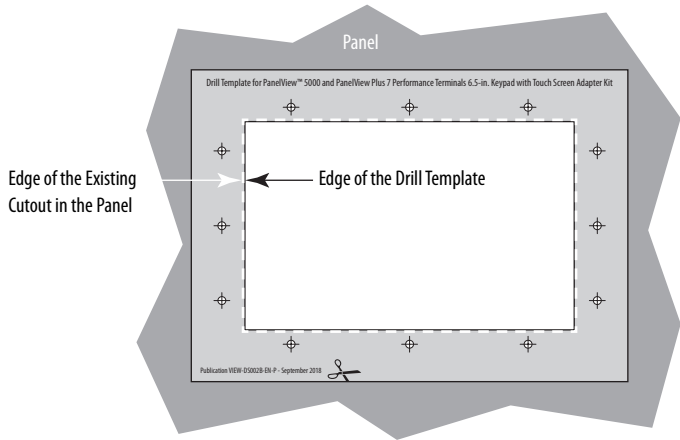

- Use the masking tape to secure the drill template to the panel.

---

**IMPORTANT** Make sure that the drill template is flat against the panel with no wrinkles or creases that can distort the drill locations.

---

- Use a center punch to mark the center of the drill locations.
- Remove the drill template and masking tape.
- Cover and protect components in the enclosure or within the drilling vicinity.



**ATTENTION:** Make sure that drill shavings do not enter any components that are installed in the enclosure or in the vicinity. Drill shavings can damage components.

- To drill the pilot holes, use the 4.76 mm (3/16 in.) drill bit.



**ATTENTION:** Use the shortest possible drill bit that will drill completely through the panel. Do not drill into any existing components inside the enclosure.

- To drill the finish holes, use the 6.35 mm (1/4 in.) drill bit.
- Remove any burrs from the drilled holes.
- Remove all drill shavings from inside the enclosure and the vicinity.
- Remove the temporary covers and protection from the enclosure and drilling vicinity.

## Install the Adapter Plate and Backing Plate

Before you install the adapter and backing plate, measure the thickness of the panel to find the correct mounting lever lock position for the new terminal installation.

### Determine the Mounting Lever Lock Position

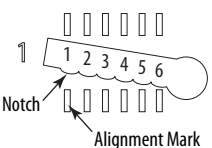
Mounting Slot	Mounting Lever Lock Position	Panel Thickness Range Before the Adapter Kit is Installed	Typical Gauge
	1	1.50...2.01 mm (0.060...0.079 in.)	16
	2	2.03...2.64 mm (0.080...0.104 in.)	14
	3	2.67...3.15 mm (0.105...0.124 in.)	12
	4	3.17...3.66 mm (0.125...0.144 in.)	10
	5	3.68...4.16 mm (0.145...0.164 in.)	8/9
	6	4.19...4.80 mm (0.165...0.188 in.)	7

Use a marker or grease pencil to mark the mounting lever lock position of each mounting slot on the back edge of the new terminal. The marked lock position helps you line up the mounting lever when you install the new terminal in [step 4](#) through [step 7](#) in [Mount the Terminal on page 9](#).

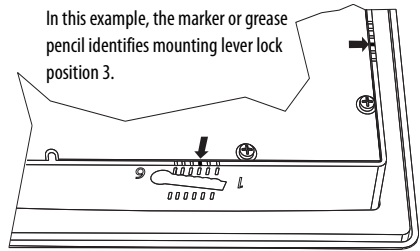

To install the adapter plate and backing plate, follow these steps.



**ATTENTION:** For the following steps, refer to [Installation Sequence on page 7](#).

1. Verify that the adapter plate and backing plate are flat and not bent.
2. Verify that the sealing gasket is installed on the adapter plate and is not damaged. This gasket forms a compression seal. Do not use sealing compounds.
3. From the front of the panel, insert the threaded studs of the adapter plate through the holes that you drilled in the panel.
4. From the back of the panel, insert the backing plate through the threaded studs of the adapter plate.

**IMPORTANT** Install the backing plate with the raised spacers facing the panel.

5. Finger tighten one nut onto each of the threaded studs. Be sure to hold the backing plate securely until at least two nuts are in place.

- Follow the tightening sequence on page 7 for your terminal adapter kit.



**ATTENTION:** To maintain a NEMA Type 4X rating, torque the nuts to 3.90 N·m (30 lb·in).

Rockwell Automation is not responsible for water or chemical damage to the terminal, or other equipment within the panel, due to improper installation.

### Installation Sequence

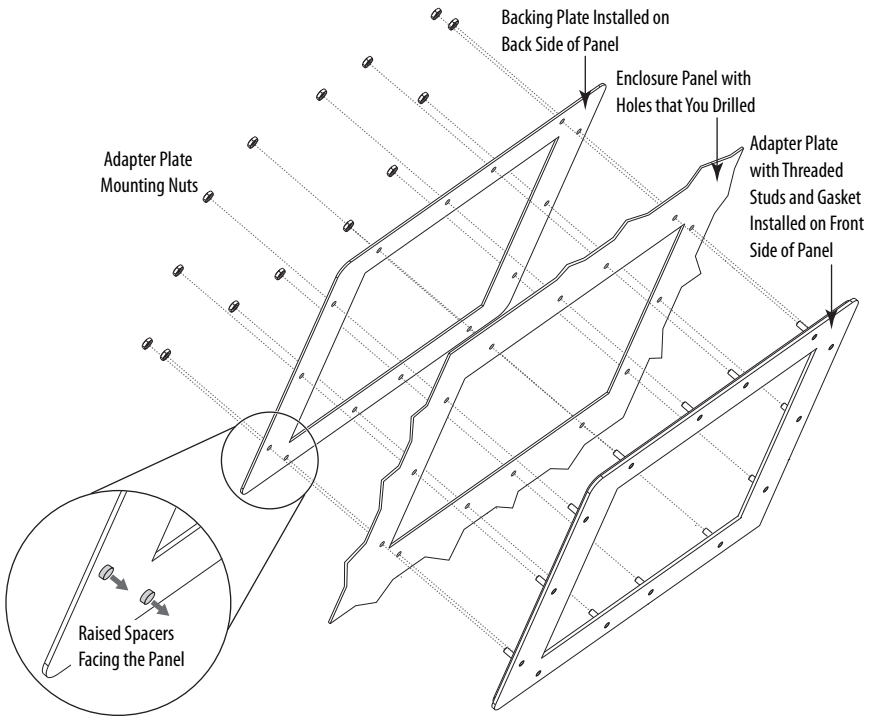

### Torque Sequence for Adapter Plate Mounting Nuts—3.90 N·m (30 lb·in)

All 6.5-in. Terminals—  
12 Mounting Nuts

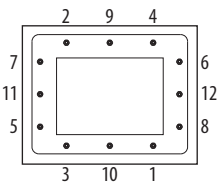

All 10.4-in. Terminals—  
14 Mounting Nuts

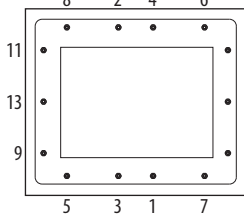

All 12.1-in. and 15-in. Terminals—  
16 Mounting Nuts

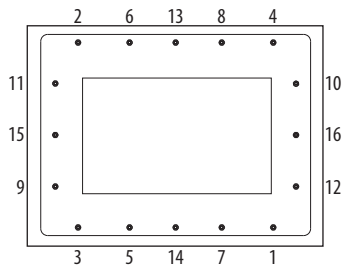

## Prepare to Mount the Terminal

Mounting levers insert into the slots around the terminal bezel to secure the terminal in the adapter plate. The number of mounting levers varies by terminal size. Each slot has six notches with alignment marks that are locking positions for a mounting lever. The thickness of the panel where the terminal is mounted determines the locking position that is required to maintain NEMA, UL Type, and IP seals. See [Determine the Mounting Lever Lock Position on page 6](#).

## Mounting Lever Orientation and Lock Sequence

**IMPORTANT** The mounting lever orientations that are shown are required to maintain NEMA, UL Type, and IP seals. If you require a NEMA, UL Type, or IP seal, do not use a mounting lever in another orientation than shown. See [Mounting Lever Orientation and Lock Sequence on page 8](#).

### Mounting Lever Orientation and Lock Sequence

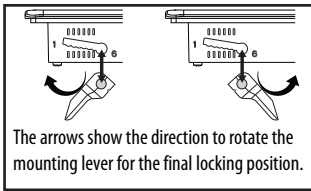

6.5-in. Touch Only—6 Levers

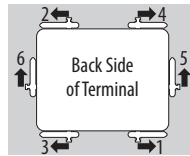

6.5-in. Keypad and Touch—8 Levers

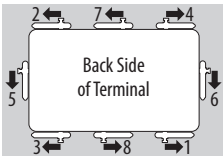

10.4-in. Touch Only—8 Levers

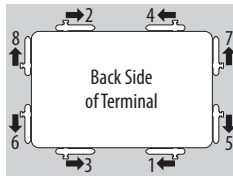

10.4-in. Keypad and Touch,  
12.1-in. Touch Only—10 Levers

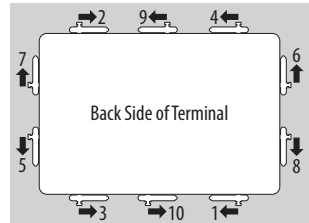

15-in. Touch Only—12 Levers

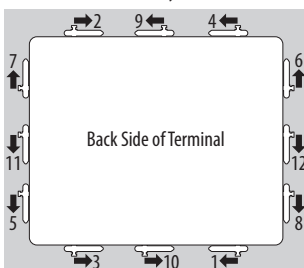

15-in. Keypad and Touch—14 Levers

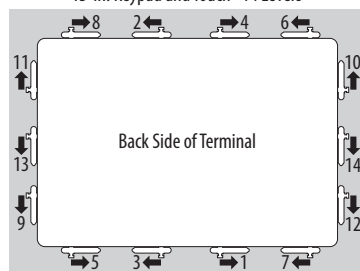



## Mount the Terminal

Installing the mounting levers is a multi-step process. Step 4 installs each lever so that the terminal is snug in the adapter plate and the gasket is slightly compressed. Step 6 moves the mounting levers into tighter locking positions until you reach the final locking position that you previously marked with a marker or grease pencil.

---

**IMPORTANT** Before you begin to mount the terminal, read this section and understand the process.

---

**IMPORTANT** Use only the adapter kit mounting levers. Do not use any other mounting levers.

---

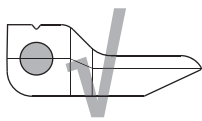

Use the Adapter Kit Mounting Levers

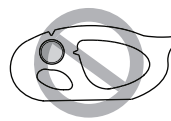

Do Not Use the Oval Mounting Levers

---

To mount the terminal in the adapter plate, follow these steps.

1. Verify that the sealing gasket is present on the terminal and is not damaged. This gasket forms a compression seal. Do not use sealing compounds.

2. Insert adapter kit mounting levers in the **top corner slots** by using the orientation in [Mounting Lever Orientation and Lock Sequence on page 8](#).

The example at right shows the top of a 6.5-in. touch screen terminal.

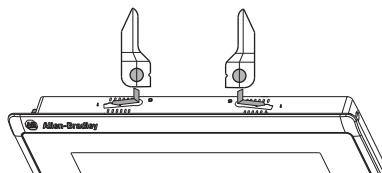

3. Tilt the terminal into the adapter plate and guide the terminal upward so that the mounting levers hold the top of the terminal in the adapter plate.

If it is difficult to insert the terminal into the adapter plate, press the bezel at the top of the terminal to compress the gasket so you can insert the terminal into the adapter plate.

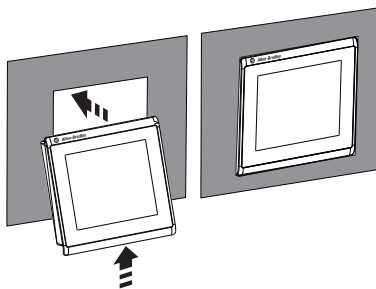

4. Insert a mounting lever in the **bottom** of the terminal to stabilize the terminal in the adapter plate.

5. Insert the remaining levers in the terminal and rotate each lever until the flat side is in contact with the backing plate and the gasket is slightly compressed.

---

**IMPORTANT** Install the mounting levers by the orientation sequence shown in [Mounting Lever Orientation and Lock Sequence on page 8](#).

---

If it is difficult to insert a mounting lever, press the bezel at the mounting lever position to compress the gasket so you can insert the mounting lever.

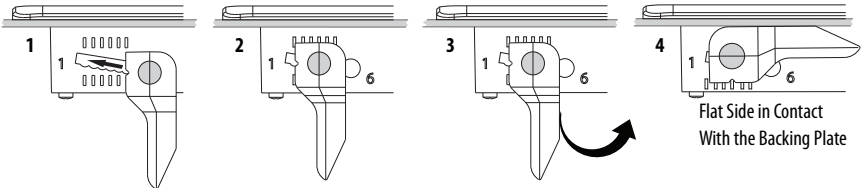

---

**IMPORTANT** Do not install the mounting levers in the final lock position yet. For example, if the final lock position is 3, slide the lever to notch 4 or 5 (see [Determine the Mounting Lever Lock Position on page 6](#)).

---

6. Readjust each mounting lever to its final lock position.
  - a. Rotate mounting lever one in the sequence away from the backing plate.
  - b. Slide the mounting lever to the final locking position.

If it is difficult to slide the mounting lever, press on the bezel at the mounting lever position to compress the gasket so you can slide the mounting lever to the final locking position.

If it is too difficult to slide a mounting lever to its final locking position, then slide the mounting lever one position at a time until you are able to slide the mounting levers to the final locking position.

- c. Rotate the mounting lever until the flat side is in contact with the backing plate.

**TIP** If the mounting levers are over torqued, the pin can break off. If a pin is broken, you can turn the mounting lever over and use the lever in another location that meets the orientation for the mounting lever.

- d. Lock the remaining mounting levers to their final position.

7. Inspect all mounting levers and verify that each lever is in the correct locked position.



**ATTENTION:** All mounting levers must be in the correct locked position and follow the correct lever installation sequence to provide an adequate gasket seal between the terminal and the adapter plate. Rockwell Automation assumes no responsibility for water or chemical damage to the terminal or other equipment within the panel because of improper installation.

The notch on the outside of mounting lever shows the locked position. The example at right shows the mounting lever locked in position 4.



The adapter plate and terminal are now installed in the panel.

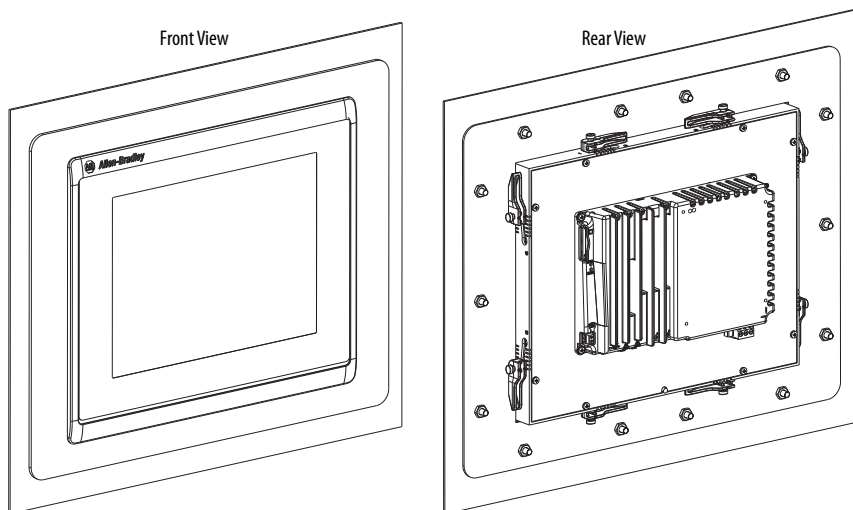

## Finish the Terminal Installation and Apply Power to the Enclosure

1. To complete the power wiring, network cabling, initial startup, and configuration of the terminal, follow the instructions in the user manual for your terminal:
  - PanelView 5310 Terminals User Manual, publication [2713P-UM001](#)
  - PanelView 5500 Terminals User Manual, publication [2715-UM001](#)
  - PanelView 5510 Terminals User Manual, publication [2715P-UM001](#)
  - PanelView Plus 7 Performance Terminals User Manual, publication [2711P-UM008](#)
2. To return power to the components in the enclosure, follow your approved sequence.

## Drill Template Dimensions

This section includes the layout dimensions for the drill locations of the adapter kit.

### 6.5-in. Only Touch – Catalog Number 2711P-RAAT7

NOTE: All dimensions are in mm (in.)

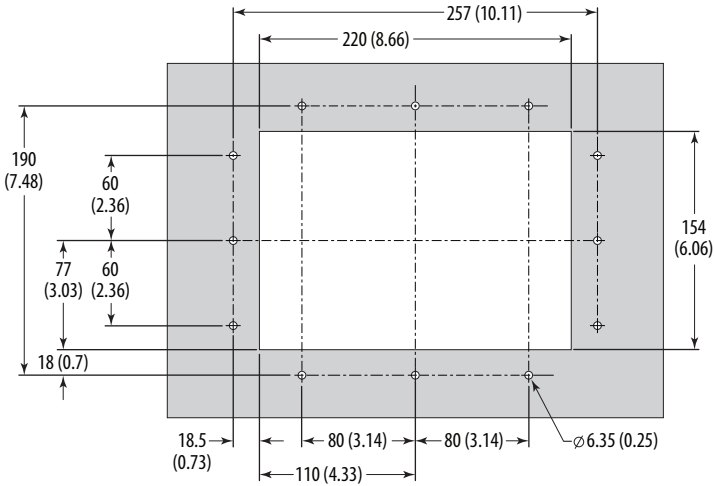

### 6.5-in. Keypad and Touch – Catalog Number 2711P-RAAK7

NOTE: All dimensions are in mm (in.)

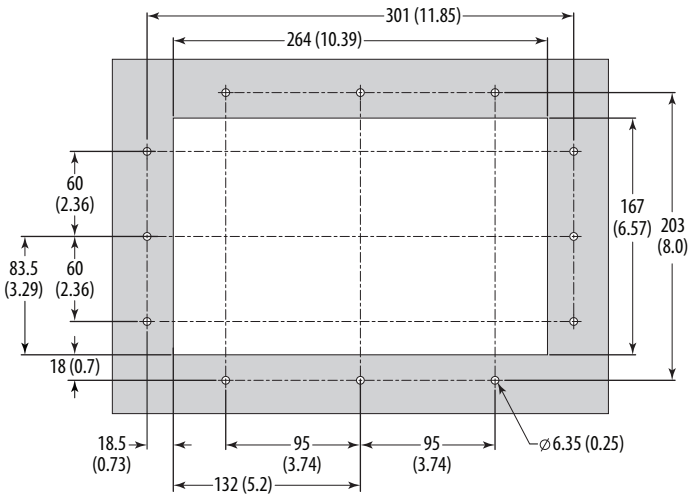

### 10.4-in. Only Touch – Catalog Number 2711P-RAAT10

NOTE: All dimensions are in mm (in.)

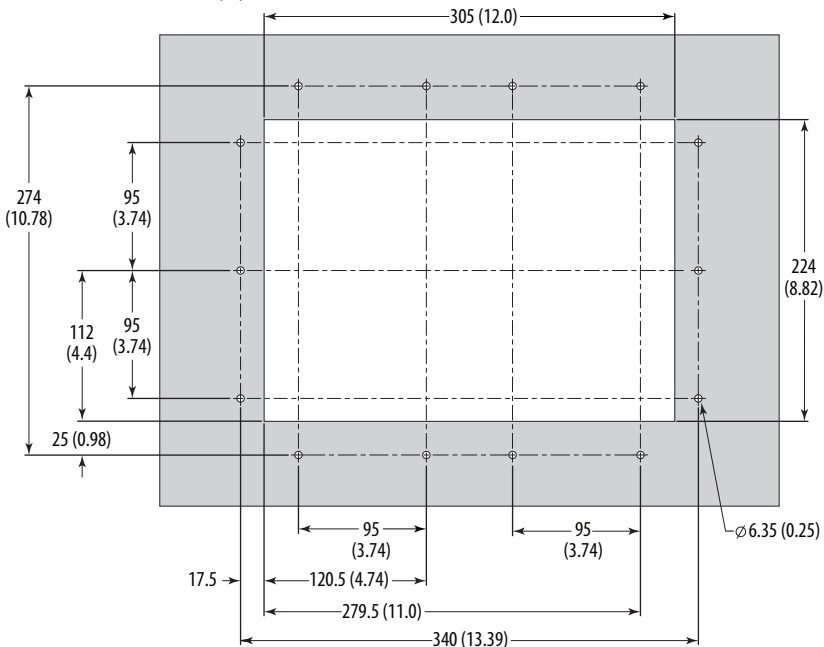

### 10.4-in. Keypad and Touch – Catalog Number 2711P-RAAK10

NOTE: All dimensions are in mm (in.)

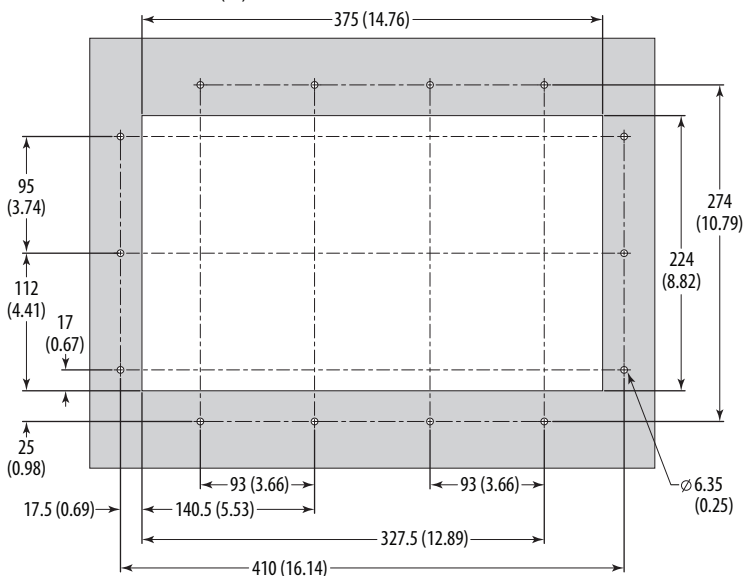



### 15-in. Only Touch – Catalog Number 2711P-RAAT15

NOTE: All dimensions are in mm (in.)

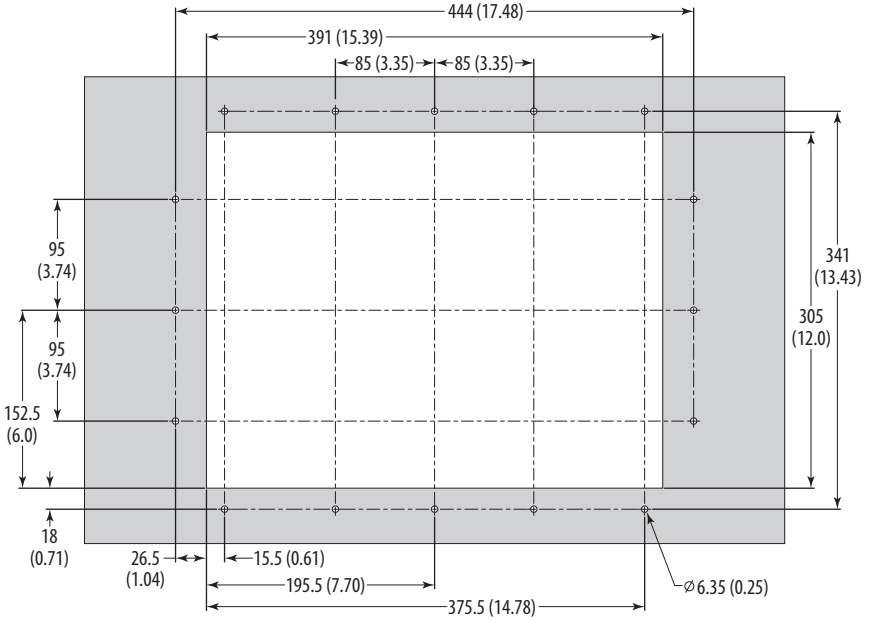

### 15-in. Keypad and Touch – Catalog Number 2711P-RAAK15

NOTE: All dimensions are in mm (in.)

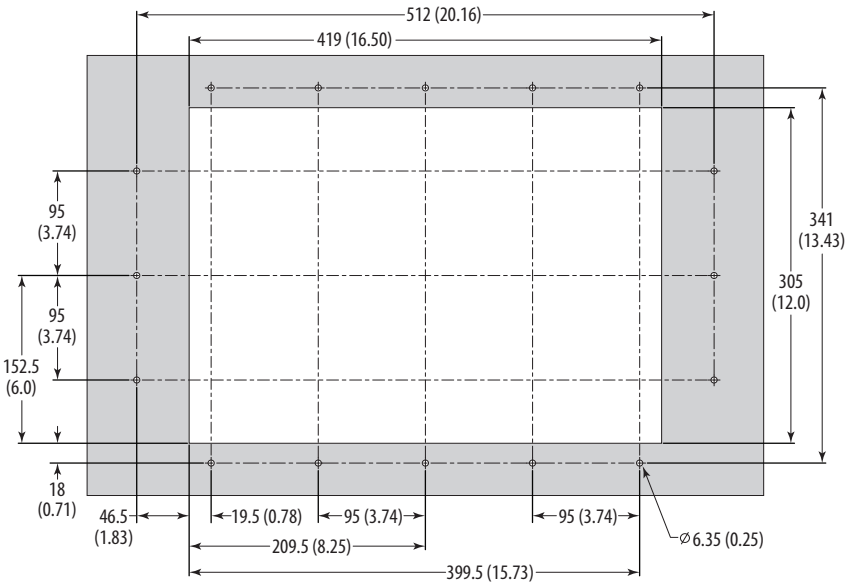

# Additional Resources

These documents contain additional information concerning related products from Rockwell Automation.

Resource	Description
<a href="#">PanelView 5310 Terminals User Manual, publication 2713P-UM001</a>	Provides information on how to install, operate, configure, and troubleshoot the PanelView 5310 terminals.
<a href="#">PanelView 5310 Terminals Technical Data, publication 2713P-TD001</a>	Provides technical specifications, environmental specifications, and certifications for the PanelView 5310 terminals.
<a href="#">PanelView 5500 Terminals User Manual, publication 2715-UM001</a>	Provides information on how to install, operate, configure, and troubleshoot the PanelView 5500 terminals.
<a href="#">PanelView 5500 Terminals Technical Data, publication 2715-TD001</a>	Provides technical specifications, environmental specifications, and certifications for the PanelView 5500 terminals.
<a href="#">PanelView 5510 Terminals User Manual, publication 2715P-UM001</a>	Provides information on how to install, operate, configure, and troubleshoot the PanelView 5510 terminals.
<a href="#">PanelView 5510 Terminals Technical Data, publication 2715P-TD001</a>	Provides technical specifications, environmental specifications, and certifications for the PanelView 5510 terminals.
<a href="#">PanelView Plus 7 Performance Terminals User Manual, publication 2711P-UM008</a>	Provides information on how to install, operate, configure, and troubleshoot the PanelView Plus 7 Performance terminals.
<a href="#">PanelView Plus 7 Performance Terminals Technical Data, publication 2711P-TD009</a>	Provides technical specifications, environmental specifications, and certifications for the PanelView Plus 7 Performance terminals.
<a href="#">Industrial Automation Wiring and Grounding Guidelines, publication 1770-4.1</a>	Provides general guidelines for installing a Rockwell Automation industrial system.
<a href="#">Product Certifications website, <a href="http://rok.auto/certifications">rok.auto/certifications</a></a>	Provides declarations of conformity, certificates, and other certification details.

You can view or download publications at <http://www.rockwellautomation.com/literature/>. To order paper copies of technical documentation, contact your local Allen-Bradley distributor or Rockwell Automation sales representative.

Rockwell Automation maintains current product environmental information on its website at <http://www.rockwellautomation.com/rockwellautomation/about-us/sustainability-ethics/product-environmental-compliance.page>.

Allen-Bradley, Rockwell Automation, and Rockwell Software are trademarks of Rockwell Automation, Inc. Trademarks not belonging to Rockwell Automation are property of their respective companies.

Rockwell Otomasyon Ticaret A.Ş., Kar Plaza İş Merkezi E Blok Kat:6 34752 Çerçenköy, İstanbul, Tel: +90 (216) 5698400

[www.rockwellautomation.com](http://www.rockwellautomation.com)

### Power, Control and Information Solutions Headquarters

Americas: Rockwell Automation, 1201 South Second Street, Milwaukee, WI 53204-2496 USA, Tel: (1) 414.382.2000, Fax: (1) 414.382.4444  
Europe/Middle East/Africa: Rockwell Automation NV, Pegasus Park, De Kleerlaan 12a, 1831 Diegem, Belgium, Tel: (32) 2 663 0600, Fax: (32) 2 663 0640  
Asia Pacific: Rockwell Automation, Level 14, Core F, Cyberport 3, 100 Cyberport Road, Hong Kong, Tel: (852) 2887 4788, Fax: (852) 2508 1846



PN-518179