



Compact 5000 I/O and Specialty Modules Specifications

Catalog Numbers

Digital I/O Modules	5069-IA16, 5069-IB16, 5069-IB16F, 5069-IB16K, 5069-IB6F-3W, 5069-OA16, 5069-OB8, 5069-OB16, 5069-OB16F, 5069-OB16K, 5069-OW4I, 5069-OW16, 5069-OX4I
Analog I/O Modules	5069-IF4IH, 5069-IF8, 5069-IY4, 5069-IY4K, 5069-OF4, 5069-OF4K, 5069-OF4IH, 5069-OF8
Safety I/O Modules	5069-IB8S, 5069-IB8SK, 5069-OBV8S, 5069-OBV8SK
Specialty Modules	5069-AENTR, 5069-AENTRK, 5069-AEN2TR, 5069-ARM, 5069-FPD, 5069-HSC2XOB4, 5069-SERIAL

Topic	Page
Summary of Changes	2
Power the Compact 5000 I/O Modules	2
Minimum Space Requirements	2
Digital I/O Modules	5
Analog I/O Modules	17
Safety I/O Modules	31
Specialty Modules	39
Additional Resources	51

The Compact 5000™ I/O architecture provides a wide range of input and output modules to span many applications, from high-speed digital to process control. The architecture uses Producer/Consumer technology that allows input information and output status to be shared among multiple Logix 5000® controllers.

Compact 5000 I/O modules are used as local I/O modules in CompactLogix™ 5380 and Compact GuardLogix® 5380 controller systems. The modules are also used as remote I/O modules with CompactLogix 5380, Compact GuardLogix 5380 controllers, and some other Logix 5000 controllers. You use the Studio 5000 Logix Designer® application to configure the modules.

The I/O modules require a removable terminal block (RTB) to connect field-side wiring. RTBs are not included with the I/O modules. You must order RTBs separately.

Summary of Changes

This publication contains the following new or updated information. This list includes substantive updates only and is not intended to reflect all changes. Change bars identify changes throughout the manual.

Topic	Pages
Updated the c-UL-us certification for the digital and analog modules	6, 18
Added the HART I/O modules, 5069-IF4IH and 5069-OF4IH	Throughout

Power the Compact 5000 I/O Modules

There are different types of power that are used with Compact 5000 I/O modules.

Power Type	Description	Related Specifications	
		Name	Description
Module (MOD) Power	System-side power that is used to operate a local or remote system. Power passes across a MOD power bus. Modules draw current from the bus and pass the remaining current to the next module.	MOD power	Level of MOD power current that the module draws from the MOD power bus
		MOD power (passthrough)	Maximum level of MOD power current that the module can pass to the next module.
Sensor Actuator (SA) Power	Field-side power that some modules use to power field-side devices. Power passes across an SA power bus. Some modules draw current from the bus and pass the remaining current to the next module. Other modules do not draw current from the bus but do pass the current to the next module. You use 5069-FPD field potential distributors to establish new SA power buses in a system. IMPORTANT: <ul style="list-style-type: none"> If the system includes DC type modules and AC type modules, you must use a field potential distributor to install them on separate SA power buses. You cannot install AC type modules directly next to a Compact GuardLogix 5380 controller. You must first install a field potential distributor. 	SA power	Level of SA power current that the module draws from the SA power bus
		SA power (passthrough)	Maximum level of SA power current that the module can pass to the next module.
Local Actuator (LA) Power	Field-side power that some Compact 5000 I/O modules use instead of SA power. Modules that use LA power do not use SA power . They only pass SA power to the next I/O module in the system. You must install modules that use LA power on an SA power bus with the same SA power type. For example, the 5069-OB8 module uses LA power but is still a DC-type module, so you must install it on a DC SA power bus.	LA power	Maximum level of LA power current that you can apply to the module, by channel, group, or module.

For more information on MOD power, SA power, and LA power, see the user manuals in [Additional Resources on page 51](#).

Minimum Space Requirements

There are minimum space requirements that are based on whether Compact 5000 I/O modules are installed in a CompactLogix™ 5380, Compact GuardLogix® 5380, CompactLogix 5480 controller system or in a Compact 5000 I/O EtherNet/IP™ adapter system.

IMPORTANT	<p>If Compact 5000 I/O modules are installed next to a CompactLogix 5380 or Compact GuardLogix 5380, or CompactLogix 5480 controller, you must mount the system horizontally.</p> <p>You can mount CompactLogix 5480 controllers in any orientation if there are no Compact 5000 I/O modules installed next to the controller.</p>
------------------	--

CompactLogix 5380 or Compact GuardLogix 5380 System Minimum Space Requirements

The minimum distance between all sides of the CompactLogix 5380 system or Compact GuardLogix 5380 system and enclosure walls, wireways, and adjacent equipment varies based on the current operating temperature.

Controllers	Minimum Space at		
	50 °C (122 °F)	55 °C (131 °F)	60 °C (140 °F)
CompactLogix 5380 Standard and Process Controllers	50.8 mm (2.00 in)	50.80 mm (2.00 in)	101.60 mm (4.00 in)
Compact GuardLogix 5380 SIL 2 Controllers			
Series A catalog numbers	50.8 mm (2.00 in)	101.6 mm (4.00 in)	152.4 mm (6.00 in)
Series B catalog numbers	50.8 mm (2.00 in)	50.8 mm (2.00 in)	101.6 mm (4.00 in)
Compact GuardLogix 5380 SIL 3 Controllers	50.8 mm (2.00 in)	50.8 mm (2.00 in)	101.6 mm (4.00 in)

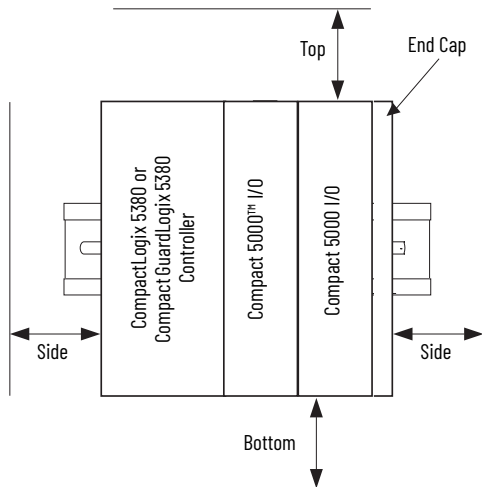

For more information on how to install a CompactLogix 5380 controller system, see the CompactLogix 5380 Controllers Installation Instructions, publication [5069-IN013](#).

For more information on how to install a Compact GuardLogix 5380 controller system, see the Compact GuardLogix 5380 SIL 2 Controllers Installation Instructions, publication [5069-IN014](#).

CompactLogix 5480 System Minimum Space Requirements

The minimum distance for a system that includes only a CompactLogix 5480 controller is as follows:

- 25.00 mm (0.98 in.) between the sides of the controller and the cabinet
- 25.00 mm (0.98 in.) between the front of the controller and the cabinet
- 50.00 mm (1.96 in.) between the top and bottom of the controller and the cabinet

We recommend that you install the controller near the bottom of the enclosure, where the ambient temperature is lower.

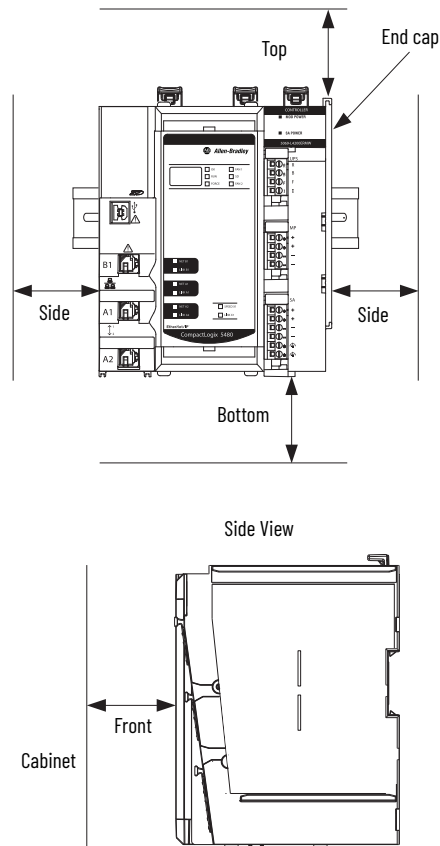

For more information on how to install a CompactLogix 5480 controller system, see the CompactLogix 5480 Controllers Installation Instructions, publication [5069-IN019](#).

Adapter Minimum Space Requirements

The minimum distance on all sides of the adapter system is as follows:

- 25.40 mm (1.00 in) - If the system uses only Compact 5000 I/O standard modules.
- 50.80 mm (2.00 in) - If the system uses at least one Compact 5000 I/O safety module.

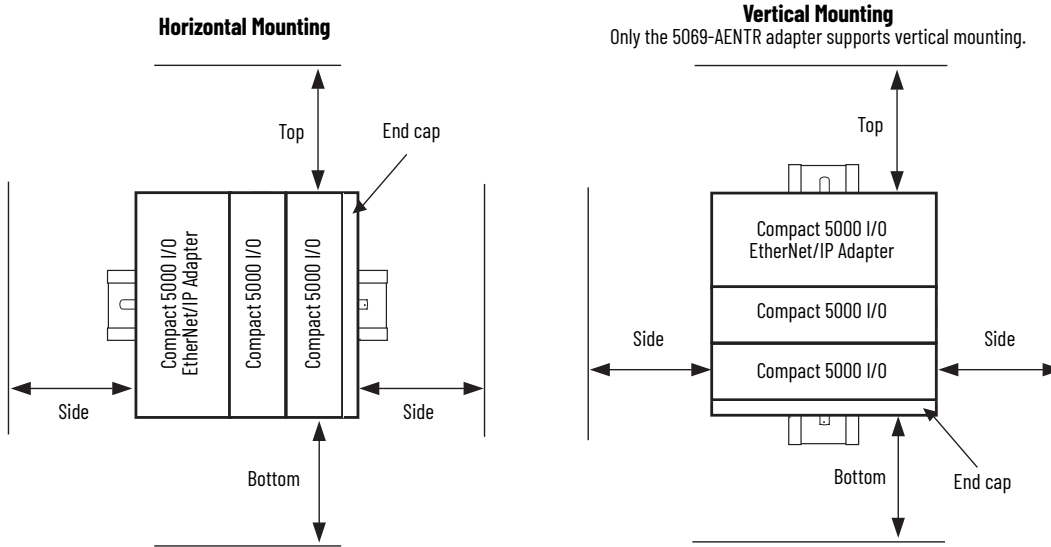

For more information on how to install a Compact 5000 I/O EtherNet/IP adapter system, see the Compact 5000 I/O EtherNet/IP Adapters Installation Instructions, publication [5069-IN003](#).

Digital I/O Modules

For information that applies to all of the digital I/O modules, see these tables.

- [Wiring and Installation Specifications - Digital I/O Modules](#)
- [Certifications - Digital I/O Modules](#)
- [Environmental Specifications - Digital I/O Modules](#)

The following digital I/O modules are available.

I/O Type	Cat. No.	Description	Page
AC digital input	5069-IA16	16-point 120/240V AC input module	7
DC digital input	5069-IB16	16-point sinking input module	8
	5069-IB16K	16-point, conformal-coated sinking input module	
	5069-IB16F	16-point, sinking fast input module	9
	5069-IB6F-3W	3-wire, sinking fast input module	
AC digital output	5069-OA16	16-point 120/240V AC output module	10
DC digital output	5069-OB8	8-point 24V DC output module	11
	5069-OB16	16-point, sourcing, high-current output module	12
	5069-OB16K	16-point, conformal-coated sourcing output module	
	5069-OB16F	16-point, sourcing fast output module	
Relay output	5069-OW4I	4-point, isolated, normally-open relay output module	13
	5069-OW16	16-point, normally-open relay output module	14
	5069-OX4I	4-point, isolated, normally-open/normally-closed relay output module	16

Wiring and Installation Specifications - Digital I/O Modules

Attribute	5069-IA16, 5069-IB16, 5069-IB16K, 5069-IB16F, 5069-IB6F-3W, 5069-OA16, 5069-OB8, 5069-OB16, 5069-OB16K, 5069-OB16F, 5069-OW4I, 5069-OX4I	5069-OW16
Channel connections	The wiring diagrams show devices that are connected to specific channels. You are not restricted to using only those channels. You can connect devices to any channel or combination of channels as needed.	
SA power device list	Connections to an external power supply that provides SA power via the SA power RTB on one of these devices. <ul style="list-style-type: none"> • CompactLogix 5380 controller • CompactLogix 5480 controller • 5069-AENTR EtherNet/IP Adapter • 5069-FPD field potential distributor 	
Isolate SA power	If you install modules in a system that uses both AC SA power and DC SA power, you must isolate SA power buses by type with a 5069-FPD field potential distributor. To create separate SA power buses, complete these steps. <ol style="list-style-type: none"> 1. Install the modules that use one type of SA power, for example DC, to the right of the adapter or controller. This is the first SA power bus. 2. To create a second SA power bus, install the 5069-FPD field module to the right of these modules. 3. Install the modules that use the other type of SA power, for example AC, to the right of the 5069-FPD module. 	
Slot width	1	1.5
Dimensions (HxWxD)	144.57 x 22 x 105.42 mm (5.69 x 0.87 x 4.15 in.)	144.57 x 36 x 105.42 mm (5.69 x 1.42 x 4.15 in.)
Weight, approx	175 g (0.39 lb)	240 g (0.53 lb.)
DIN rail	Compatible zinc-plated chromate-passivated steel DIN rail. You can use the EN50022 - 35 x 7.5 mm (1.38 x 0.30 in.) DIN rail.	
Module keying	Electronic keying via programming software	
RTB	5069-RTB18-SPRING RTB or 5069-RTB18-SCREW RTB, according to your system NOTE: RTBs do not ship with Compact 5000™ I/O modules, you must order them separately. Order only the RTB type that your system requires.	
RTB torque	Screw-type RTB only: 0.4 N•m (3.5 lb•in)	
RTB keying	None	
Wire size	0.5...1.5 mm ² (22...16 AWG) solid or stranded shielded copper wire rated at 105 °C (221 °F) or greater 5069-RTB18-SPRING RTB: 2.9 mm (0.11 in.) max diameter including insulation, single wire connection only. 5069-RTB18-SCREW RTB: 3.5 mm (0.14 in.) max diameter including insulation, single wire connection only. For the 5069-OW16 module only: Use minimum 18 AWG, 105 °C (221 °F) rated wire for load connections to relay output modules.	
Insulation-stripping length	5069-RTB18-SPRING RTB: 10 mm (0.39 in.) 5069-RTB18-SCREW RTB: 12 mm (0.47 in.)	

Environmental Specifications - Digital I/O Modules

Attribute	5069-IA16, 5069-OA16, 5069-OB8, 5069-OW16	5069-OW4I, 5069-OX4I	5069-IB16, 5069-IB16K, 5069-IB16F, 5069-IB6F-3W, 5069-OB16, 5069-OB16K, 5069-OB16F
Temperature, operating IEC 60068-2-1 (Test Ad, Operating Cold) IEC 60068-2-2 (Test Bd, Operating Dry Heat) IEC 60068-2-14 (Test Nb, Operating Thermal Shock)	0...60 °C (32...140 °F)		
Temperature, surrounding air, max	60 °C (140 °F)		
Temperature, nonoperating IEC 60068-2-1 (Test Ab, Unpackaged Nonoperating Cold) IEC 60068-2-2 (Test Bb, Unpackaged Nonoperating Dry Heat) IEC 60068-2-14 (Test Na, Unpackaged Nonoperating Thermal Shock)	-40...+85 °C (-40...+185 °F)		
Relative humidity IEC 60068-2-30 (Test Db, Unpackaged Damp Heat)	5...95% noncondensing		
Vibration IEC 60068-2-6 (Test Fc, Operating)	5 g @ 10...500 Hz		
Shock, operating IEC 60068-2-27 (Test Ea, Unpackaged Shock)	30 g		
Shock, nonoperating IEC 60068-2-27 (Test Ea, Unpackaged Shock)	50 g		
Emissions	IEC 61000-6-4		
ESD immunity IEC 61000-4-2	6 kV contact discharges 8 kV air discharges		
Radiated RF immunity IEC 61000-4-3	10V/m with 1 kHz sine wave 80% AM from 80...6000 MHz		
EFT/B immunity IEC 61000-4-4	±4 kV @ 5 kHz on power ports ±4 kV @ 5 kHz on signal ports	±4 kV @ 5 kHz on power ports ±3 kV @ 5 kHz on input ports	
Surge transient immunity IEC 61000-4-5	±1 kV line-line (DM) and ±2 kV line-earth (CM) on power ports ±1 kV line-line (DM) and ±2 kV line-earth (CM) on signal ports		
Conducted RF immunity IEC 61000-4-6	10V rms with 1 kHz sine wave 80% AM from 150 kHz...80 MHz		
Voltage variation IEC 61000-4-29	—	10 ms interruption on MOD power port	
Corrosion resistance classification	ISA S71.04 G2	—	
North American temp code	T4		
UKEX/ATEX temp code	T4		
IECEX temp code	T4		
Enclosure type	None (open-style)		

Certifications - Digital I/O Modules

Certification	5069-IA16, 5069-IB16, 5069-IB16K, 5069-IB16F, 5069-IB6F-3W, 5069-OA16, 5069-OB8, 5069-OB16, 5069-OB16K, 5069-OB16F	5069-OW4I, 5069-OW16, 5069-OX4I
c-UL-us	UL Listed Industrial Control Equipment, certified for US and Canada. See UL File E322657. UL Listed for Class I, Division 2 Group A,B,C,D Hazardous Locations, certified for U.S. and Canada. See UL File E334470.	
UKCA and CE	UK Statutory Instrument 2016 No. 1091 and European Union 2014/30/EU EMC Directive, compliant with: EN 61326-1; Meas./Control/Lab., Industrial Requirements EN 61000-6-2; Industrial Immunity EN 61000-6-4; Industrial Emissions EN 61131-2; Programmable Controllers (Clause 8, Zone A & B) UK Statutory Instrument 2016 No. 1101 and European Union 2014/35/EU LVD, compliant with: EN 61010-2-201; Control Equipment Safety Requirements UK Statutory Instrument 2012 No. 3032 and European Union 2011/65/EU RoHS, compliant with: EN IEC 63000; Technical documentation	
RCM	Australian Radiocommunications Act, compliant with EN 61000-6-4; Industrial Emissions	
Ex	UK Statutory Instrument 2016 No. 1107 and European Union 2014/34/EU ATEX Directive, compliant with: EN IEC 60079-0; General Requirements EN IEC 60079-7; Explosive Atmospheres, Protection "e" EN IEC 60079-15; Potentially Explosive Atmospheres, Protection "n" II 3 G Ex ec IIC T4 Gc DEMKO 15 ATEX 1484X and UL22UKEX2379X	
IECEX	IECEX System, compliant with: IEC 60079-0; General Requirements IEC 60079-7; Explosive Atmospheres, Protection "e" IEC 60079-15; Potentially Explosive Atmospheres, Protection "n" II 3 G Ex ec nC IIC T4 Gc IECEX UL 15.0055X When used at or below 125V DC or 30V DC	
KC	Korean Registration of Broadcasting and Communications Equipment, compliant with: Article 58-2 of Radio Waves Act, Clause 3	
Morocco	Arrêté ministériel n° 6404-15 du 1 er muharram 1437 Arrêté ministériel n° 6404-15 du 29 ramadan 1436	
CCC	CNCA-C23-01:2019 强制性产品认证实施规则 防爆电气 CNCA-C23-01:2019 CCC Implementation Rule Explosion-Proof Electrical Products CCC: 2020312309000308	

See the Product Certification link at rok.auto/certifications for Declarations of Conformity, Certificates, and other certification details.

5069-IA16

Digital 16-point 120/240V AC Input Module

Input Wiring - 5069-IA16

IMPORTANT:

- The 5069-IA16 module uses AC SA power. You must connect AC power to the device that supplies SA power to the module. See the [SA power device list](#).
- Compact GuardLogix 5380 controllers do not support AC power on their SA power RTBs. To install a local 5069-IA16 module in a Compact GuardLogix 5380 controller system, complete the steps in [Isolate SA power](#).
- The 5069-IA16 module inputs use a shared common. The inputs have a return through internal module circuitry to the SA (-) terminal on the SA power RTB. For more information, see [Power the Compact 5000 I/O Modules](#).

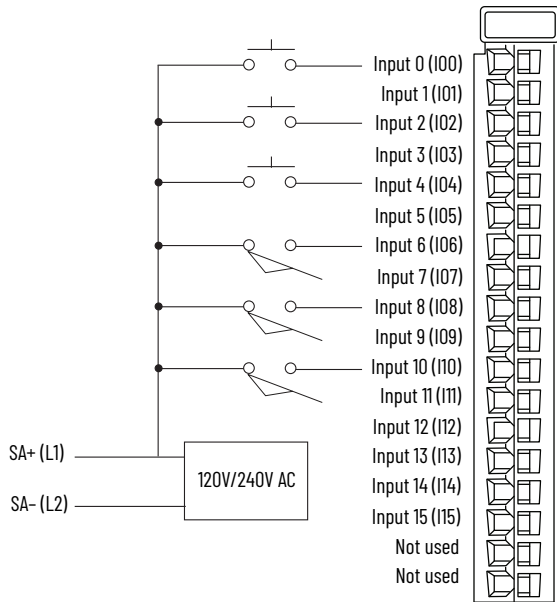

Functional Block Diagram - 5069-IA16

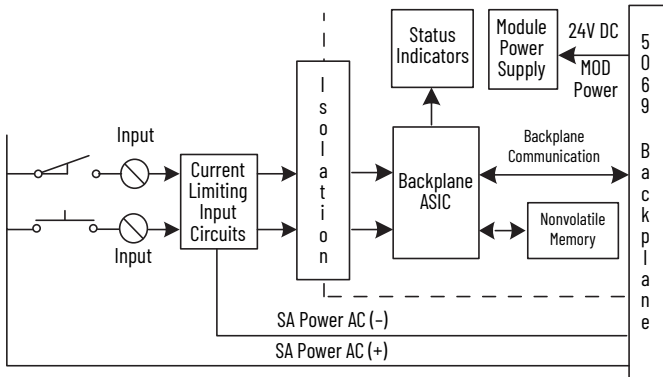

Technical Specifications - 5069-IA16

Attribute	5069-IA16
Number of inputs	16 (One group of 16)
Voltage category	120/240V AC
Voltage and current ratings	
Input voltage range	79...264V AC
Input voltage frequency	47...63 Hz
MOD power	75 mA @ 18...32V DC
MOD power (passthrough) ⁽¹⁾	9.55 A @ 18...32V DC
SA power	240 mA @ 79...264V AC
SA power (passthrough) ⁽¹⁾	9.975 A @ 79...264V AC

Do not exceed 10 A MOD or SA power (passthrough) current draw.
The 5069-IA16 module complies to UKEX/ATEX/IECEx when used at or below 125V AC.

Technical Specifications - 5069-IA16

Attribute	5069-IA16
Power dissipation, max	3.5 W
Thermal dissipation, max	11.9 BTU/hr
Isolation voltage	250V (continuous), Basic Insulation Type Type tested at 1800V AC for 60 s No isolation between individual channels
Indicators	1 green/red module status indicator 16 yellow/red I/O status indicators
Wire category ⁽²⁾	1 - input port 1 wire per terminal for each signal port
IEC Input Compatibility	Type 1
On-state voltage, min	79V AC
On-state voltage, nom	120/240V AC
On-state voltage, max	264V AC
Off-state voltage, max	40V AC
Input current per channel, max	15 mA @ 264V AC
On-state current, min	2 mA @ 79V AC 3 mA @ 164V AC
On-state current, nom	5 mA @ 120V AC/50 Hz 6 mA @ 120V AC/60 Hz 9 mA @ 240V AC/50 Hz 11 mA @ 240V AC/60 Hz
On-state current, max	15 mA @ 264V AC
Off-state current, max	2 mA
Input impedance, nom	24 kΩ @ 120V AC/50 Hz 20 kΩ @ 120V AC/60 Hz 27 kΩ @ 240V AC/50 Hz 22 kΩ @ 240V AC/60 Hz
Input impedance, min	17.6 kΩ @ 264V AC/63 Hz
Inrush current, max	600 mA
Input delay time, Off to On and On to Off	10 ms (typ) @ 0...60 °C (32...140 °F)
Input filter times	
Off to On	Hardware delay: 10 ms (typ) + filter time User-selectable filter times: 120V AC input - 1 ms 240V AC input - 1 ms, 2 ms, 5 ms
On to Off	Hardware delay: 10 ms (typ) + filter time User-selectable filter times: 120V AC input - 10 ms, 20 ms 240V AC input - 5 ms, 10 ms, 20 ms

With the 5069-IA16 module, the Logix Designer application lets you choose multiple filter values, including values that are invalid for some input signals. For example, the only valid Off to On filter value when a 120V AC signal is connected to the module is 1 ms. However, you can choose 1 ms, 2 ms, or 5 ms. If you select an invalid input filter value, the module can read signal levels incorrectly. For more information, see the Compact 5000 I/O Digital Modules User Manual, publication [5069-UM004](#).

- The level of Mod power or SA power current that passes through the module. This level depends on the system configuration, such as, module slot location and the other module types that are used in the system. For more information, see the controller user manuals in the [Additional Resources](#).
- Use this Conductor Category information to plan conductor routes. See the Industrial Automation Wiring and Grounding Guidelines, publication [1770-4.1](#).

For **Wiring and Installation Specifications**, see [page 5](#).

For **Certifications**, see [page 6](#).

For **Environmental Specifications**, see [page 6](#).

5069-IB16, 5069-IB16K, 5069-IB16F

Digital 16-point Sinking Input Modules

Input Wiring - 5069-IB16, 5069-IB16K, 5069-IB16F

IMPORTANT:

- These modules use DC SA power. You must connect DC power to the device that supplies SA power to the module. See the [SA power device list](#) and [Isolate SA power](#).
- The 5069-IB16 and 5069-IB16F module inputs use a shared common. The inputs have a return through internal module circuitry to the SA (-) terminal on the SA power RTB. For more information, see [Power the Compact 5000 I/O Modules](#).

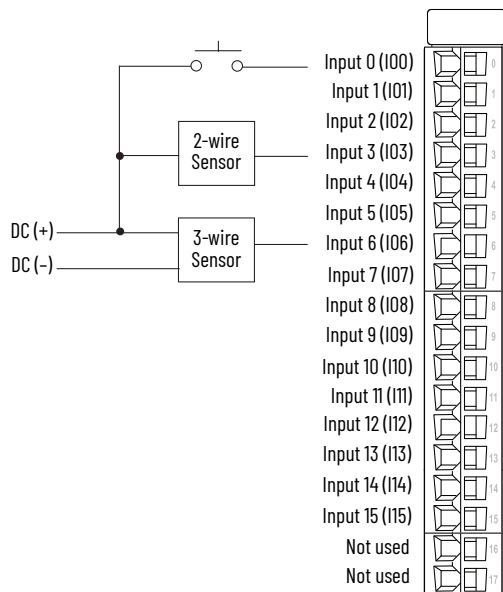

Functional Block Diagram - 5069-IB16, 5069-IB16K, 5069-IB16F

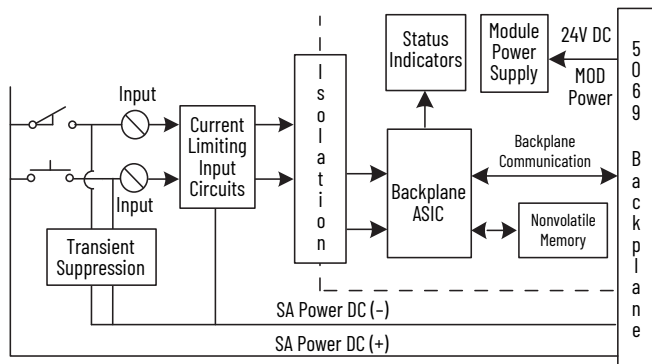

Technical Specifications - 5069-IB16, 5069-IB16K, and 5069-IB16F

Attribute	5069-IB16, 5069-IB16K	5069-IB16F
Inputs	16 Channels (1 group of 16), sinking	
Voltage category	12/24V DC Sink	
Voltage and current ratings		
Input ratings	4...7.4 mA per channel @ 10...32V DC	
MOD power	75 mA @ 18...32V DC	
MOD power (passthrough) ⁽¹⁾	9.55 A @ 18...32V DC	
SA power	200 mA @ 10...32V DC	
SA power (passthrough) ⁽¹⁾	9.95 A @ 10...32V DC	
Power dissipation, max	3.9 W	
Thermal dissipation, max	13.3 BTU/hr	
Isolation voltage	250V (continuous), Basic Insulation Type No isolation between SA power and input ports No isolation between individual input ports	

Technical Specifications - 5069-IB16, 5069-IB16K, and 5069-IB16F

Attribute	5069-IB16, 5069-IB16K	5069-IB16F
Indicators	1 green/red module status indicator 16 yellow/red I/O status indicators	
Wire category ⁽²⁾	2 - input ports 1 wire per terminal for each signal port	
On-state voltage, min	10V DC	
On-state voltage, nom	24V DC	
On-state voltage, max	32V DC	
On-state current, min	4 mA @ 10V	
On-state current, nom	6 mA @ 24V DC	
On-state current, max	7.4 mA @ 32V DC	
Off-state voltage, max	5V DC	
Off-state current, max	1.5 mA	
Input impedance, min	1.33 kΩ	
Input impedance, nom	4.1 kΩ	
Input impedance, max	7.0 kΩ	
Inrush current, max	< 250 mA peak (decaying to, 37% in 22 ms, without activation)	
Input delay time (screw to backplane) Off to On and On to Off	≤ 100 μs, ±10 μs @ 25 °C (77 °F)	≤ 10 μs, ±1 μs @ 25 °C (77 °F)
Input drift over temperature span	±100 ns/°C (55.6 ns/°F) from 0...60 °C (32...140 °F)	< 10 ns/°C (5.56 ns/°F) from 0...60 °C (32...140 °F)
Input pulse width, min Off to ON and ON to Off	60 μs	6 μs
Input filter time Off to On and On to Off	Hardware delay: 50 μs + filter time User-selectable filter time: 0...50 ms	Hardware delay: Off to On - 2 μs + filter time On to Off - 3 μs + filter time User-selectable filter time: 0...50 ms
Reverse polarity protection	Yes	
Overvoltage protection, max	36V (fuse protected)	
Counter frequency	0 - f _{max} = 500 Hz (Inv period 2 ms)	0 - f _{max} = 30 kHz (Inv period 33.3 μs)
Frequency counter	0 - f _{max} = 500 Hz (Inv period 2 ms)	0 - f _{max} = 30 kHz (Inv period 33.3 μs)
Pulse and period measurements	±2 μs	
Time stamp of inputs	±10 μs accuracy 1 ns resolution	
Pulse latching	Supported	
Events	4 events supported (triggered by any input or simple counters)	
Pattern matching	Supported	
Features, not supported	The modules do not support these features. <ul style="list-style-type: none"> • Overrides • Extended counters 	

(1) The level of Mod power or SA power current that passes through the module. This level depends on the system configuration, such as, module slot location and the other module types that are used in the system. For more information, see the controller user manuals in the [Additional Resources](#).

(2) Use this Conductor Category information to plan conductor routes. See the Industrial Automation Wiring and Grounding Guidelines, publication [1770-4.1](#).

For **Wiring and Installation Specifications**, see [page 5](#).
 For **Certifications**, see [page 6](#).
 For **Environmental Specifications**, see [page 6](#).

5069-IB6F-3W

Digital 3-wire Sinking Input Module

Input Wiring - 5069-IB6F-3W

IMPORTANT:

The 5069-IB6F-3W module uses DC SA power. You must connect DC power to the device that supplies SA power to the module. See the [SA power device list](#) and [Isolate SA power](#).

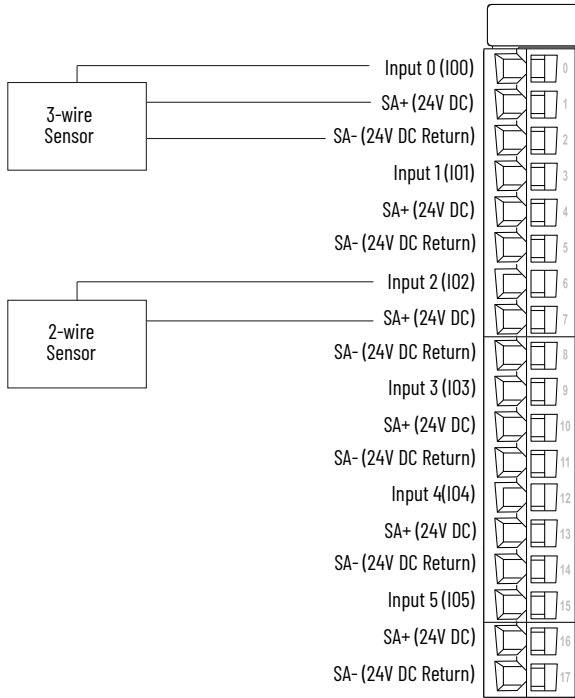

Functional Block Diagram - 5069-IB6F-3W

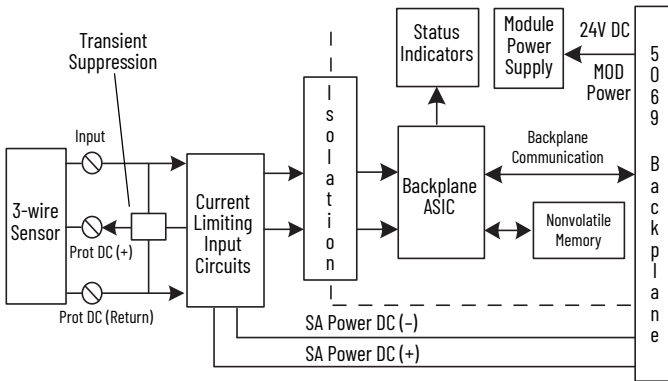

Technical Specifications - 5069-IB6F-3W

Attribute	5069-IB6F-3W
Inputs	6 Channels (1 group of 6), sinking
Voltage category	12/24V DC Sink
Voltage and current ratings	
Input ratings	4...7.4 mA per channel @ 10...32V DC
Output supply ratings	150 mA per channel @ 10...32V DC 900 mA per module @ 10...32V DC
MOD power	75 mA @ 18V...32V DC
MOD power (passthrough) ⁽¹⁾	9.55 A @ 18...32V DC
SA power	900 mA @ 10...32V DC
SA power (passthrough) ⁽¹⁾	9.95 A @ 10...32V DC
Do not exceed 10 A MOD or SA power (passthrough) current draw.	

Technical Specifications - 5069-IB6F-3W

Attribute	5069-IB6F-3W
Power dissipation, max	2.4 W
Thermal dissipation, max	8.1 BTU/hr
Isolation voltage	250V (continuous), Basic Insulation Type No isolation between SA power and input ports No isolation between individual input ports
Indicators	1 green/red module status indicator 6 yellow/red I/O status indicators
Wire category ⁽²⁾	2 - input ports 2 - power ports 1 wire per terminal for each signal port
On-state voltage, range	10V DC...32V DC
On-state voltage, nom	24V DC
Off-state voltage, max	5V DC
On-state current, min	4 mA @ 10V DC
On-state current, nom	6 mA @ 24V DC
On-state current, max	7.4 mA @ 32V DC
Off-state current, max	1.5 mA
Input impedance, nom	4.1 kΩ
Input impedance, max	7.0 kΩ
Inrush current, max	< 250 mA peak (decaying to, 37% in 22 ms, without activation)
Input delay time (screw to backplane) Off to On and On to Off	≤ 10 μs, ±1 μs @ 25 °C (77 °F)
Input drift over temperature span	±10 ns/°C (5.56 ns/°F) from 0...60 °C (32...140 °F)
Input minimum pulse width Off to On and On to Off	6 μs
Input filter time	Hardware delay Off to On: 2 μs + filter time Hardware delay On to Off: 3 μs + filter time User-selectable filter time Off to On and On to Off: 0...50 ms
Reverse polarity protection	Yes
Overvoltage protection, max	36V (fuse protected)
Pulse width and period measurements	±2 μs
Simple counters Counter frequency	0 - f _{max} = 30 kHz (Inv period 33.3 μs)
Frequency counter	0 - f _{max} = 30 kHz (Inv period 33.3 μs)
Time stamp of inputs	±10 μs accuracy 1 ns resolution
Events	4 events supported (triggered by any input or simple counters)
Features, supported	The module supports these features. <ul style="list-style-type: none"> Pulse latching Pattern matching
Features, not supported	The module does not support these features. <ul style="list-style-type: none"> Overrides Extended counters

(1) The level of Mod power or SA power current that passes through the module. This level depends on the system configuration, such as, module slot location and the other module types that are used in the system. For more information, see the controller user manuals in the [Additional Resources](#).

(2) Use this Conductor Category information to plan conductor routes. See the Industrial Automation Wiring and Grounding Guidelines, publication [1770-4.1](#).

For **Wiring and Installation Specifications**, see [page 5](#).
 For **Certifications**, see [page 6](#).
 For **Environmental Specifications**, see [page 6](#).

5069-0A16

Digital 16-point 120/240V AC Output Module

Output Wiring - 5069-0A16

IMPORTANT:

- The 5069-0A16 module uses AC SA power. You must connect AC power to the device that supplies SA power to the module. See the [SA power device list](#) and [Isolate SA power](#).
- Compact GuardLogix 5380 controllers do not support AC power on their SA power RTBs. To install a local 5069-0A16 module in a Compact GuardLogix 5380 controller system, complete the steps in [Isolate SA power](#).
- The 5069-0A16 module outputs use a shared common. The outputs have a return through internal module circuitry to the SA (-) terminal on the SA power RTB. For more information, see [Power the Compact 5000 I/O Modules](#).

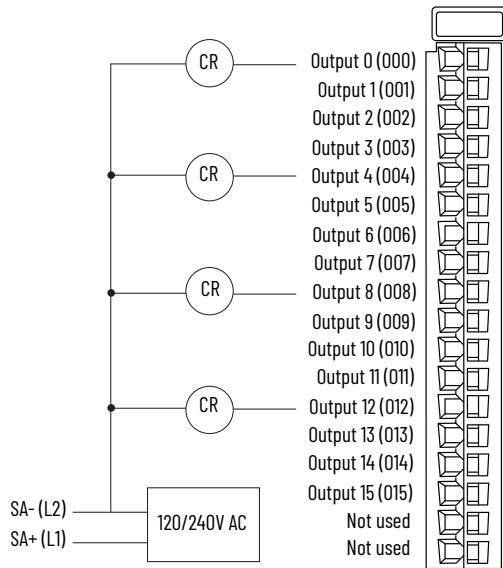

Functional Block Diagram - 5069-0A16

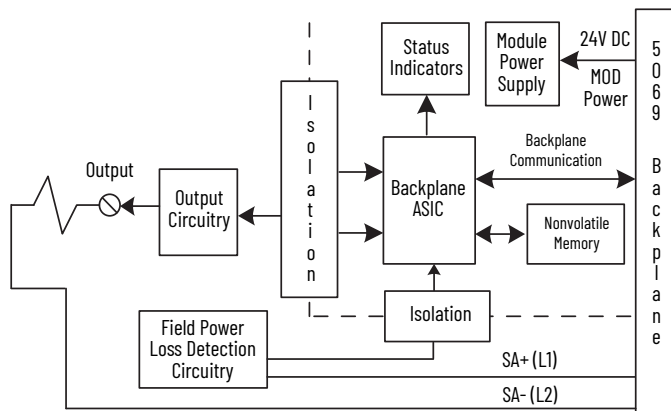

Technical Specifications - 5069-0A16

Attribute	5069-0A16
Number of outputs	16 (One group of 16)
Voltage category	120/240V AC
Voltage and current ratings	
Output voltage range	85...264V AC
Output voltage frequency	47...63 Hz
MOD power	100 mA @ 18...32V DC
MOD power (passthrough) ⁽¹⁾	9.55 A @ 18...32V DC
SA power	4 A @ 85...264V AC
SA power (passthrough) ⁽¹⁾	9.975 A @ 85...264V AC

Do not exceed 10 A MOD or SA power (passthrough) current draw. The 5069-0A16 module complies to UKEX/ATEX/IECEx when used at or below 125V AC.

Technical Specifications - 5069-0A16

Attribute	5069-0A16
Power dissipation, max	3.4 W
Thermal dissipation, max	11.6 BTU/hr
Isolation voltage	250V (continuous), Basic Insulation Type Type tested at 1800V AC for 60 s No isolation between individual channels
Indicators	1 green/red module status indicator 16 yellow/red I/O status indicators
Wire category ⁽²⁾	1 - output port 1 - power port 1 wire per terminal for each signal port
On-state voltage, min	85V AC
On-state voltage, nom	120/240V AC
On-state voltage, max	264V AC
On-state voltage drop, max	1.5V AC @ 0.5 A
Output current per channel, max	0.5 A
Output current per module, max	4 A
Off-state leakage current, max	1 mA NOTE: To limit the effects of leakage current through solid-state outputs, you can connect a loading resistor in parallel with your load. For 120V AC operation, use a 15 kΩ, 2 W resistor. For 240V AC operation, use a 15 kΩ, 5 W resistor.
Surge current per point	5 A max for 25 ms per point, repeatable every 2 s
Output delay time (backplane to screw) Off to On and On to Off	1/2 cycle time (typ) @ 0...60 °C (32...140 °F)
Field power loss detection	Yes
Features, not supported	The module does not support these features. <ul style="list-style-type: none"> No load detection per channel diagnostics Output short circuit/overload/overtemp detection per channel diagnostics Output short circuit/overload protection Reverse voltage protection Overvoltage protection Scheduled outputs
Pilot duty rating	Resistive/General Pilot Duty 0.5 A pilot duty
Output control in fault state per point	
Output states in program mode per point	<ul style="list-style-type: none"> Hold Last State On Off (default)
Output states in fault mode per point	
Duration of fault mode per point	<ul style="list-style-type: none"> 1, 2, 5, or 10 seconds Forever (default)

(1) The level of Mod power or SA power current that passes through the module. This level depends on the system configuration, such as, module slot location and the other module types that are used in the system. For more information, see the controller user manuals in the [Additional Resources](#).

(2) Use this Conductor Category information to plan conductor routes. See the Industrial Automation Wiring and Grounding Guidelines, publication [1770-4.1](#).

For **Wiring and Installation Specifications**, see [page 5](#).

For **Certifications**, see [page 6](#).

For **Environmental Specifications**, see [page 6](#).

5069-0B8

Digital 8-point 24V DC Output Module

Output Wiring - 5069-0B8

IMPORTANT:

- The 5069-0B8 module does not draw current from the SA power bus. Still, the module is a DC-type module, and you must install it on a DC SA power bus.
- The LA+ and LA- connections are used to supply field-side power to the module. Output channels 0...3 use LA0 +/-, and output channels 4...7 use LA1 +/-.

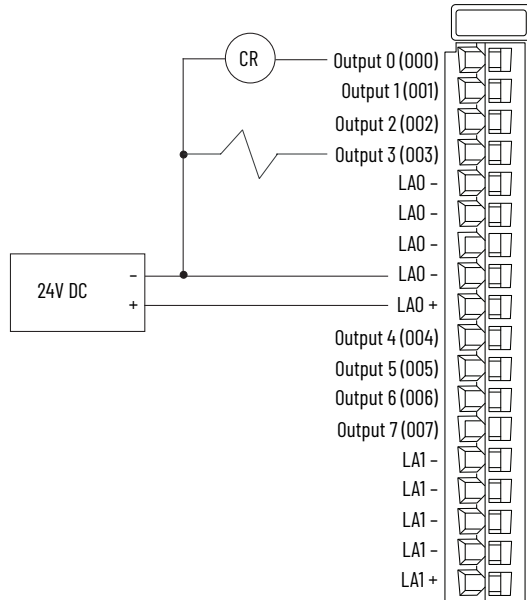

Functional Block Diagram - 5069-0B8

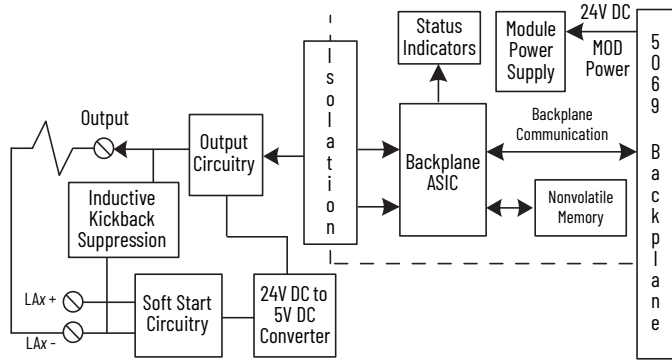

Technical Specifications - 5069-0B8

Attribute	5069-0B8
Number of outputs	8 (two groups of 4)
Voltage category	24V DC
Voltage and current ratings	
Output voltage range	10...32V DC
MOD power	75 mA @ 18...32V DC
MOD power (passthrough) ⁽¹⁾	9.55 A @ 18...32V DC
LA power	2 A per channel @ 10...32V DC 8 A per group @ 10...32V DC 16 A per module @ 10...32V DC
SA power (passthrough) ⁽¹⁾	9.95 A @ 10...32V DC NOTE: The module does not draw SA power current.
Do not exceed 10 A MOD or SA power (passthrough) current draw.	
Power dissipation, max	3.2 W
Thermal dissipation, max	10.9 BTU/hr

Technical Specifications - 5069-0B8

Attribute	5069-0B8
Isolation voltage	250V (continuous), Basic Insulation Type Type tested at 1800V AC for 60 s No isolation between LA power and output ports No isolation between individual output ports
Indicators	1 green/red module status indicator 8 yellow/red I/O status indicators
Wire category ⁽²⁾	2 - output ports 2 - power ports 1 wire per terminal for each signal port
LA power attributes	
On-state voltage, min	10V DC
On-state voltage, nom	24V DC
On-state voltage, max	32V DC
On-state voltage drop, max	0.25V DC
Off-state voltage, max	< 10V DC
On-state current per channel, min	1 mA
Off-state leakage current per point, max	0.5 mA NOTE: To limit the effects of leakage current through solid-state outputs, you can connect a loading resistor in parallel with your load. For 24V DC operation, use a 5.6 kΩ, 0.5 W resistor for transistor outputs.
Output current per channel, max	2 A
Output current per group, max	8 A
Output current per module, max	16 A
Surge current per point	4 A max for 10 ms per point, repeatable every 2 s
Output delay time (backplane to screw) Off to On and On to Off	≤ 100 μs @ 25 °C (77 °F) @ 2 A
Pulse width, min	≤ 200 μs T _{on} min + T _{off} min @ 2 A @ 25 °C (77 °F)
Output drift over temperature span	±100 ns/°C (55.6 n/°F) from 0...60 °C (32...140 °F) @ 2 A
Features, supported	The module supports these features. <ul style="list-style-type: none"> Field power loss detection No load detection per channel diagnostics Output short circuit/overload/overtemp detection per channel diagnostics Output short circuit/overload protection Reverse voltage protection
Overvoltage protection, max	36V (fuse protected)
Pilot duty rating	Resistive/General Pilot Duty 2 A pilot duty
Output control in fault state per point	<ul style="list-style-type: none"> Hold Last State On Off (default)
Output states in program mode per point	
Output states in fault mode per point	
Duration of fault mode per point	<ul style="list-style-type: none"> 1, 2, 5, or 10 seconds Forever (default)

(1) The level of Mod power or SA power current that passes through the module. This level depends on the system configuration, such as, module slot location and the other module types that are used in the system. For more information, see the controller user manuals in the [Additional Resources](#).

(2) Use this Conductor Category information to plan conductor routes. See the Industrial Automation Wiring and Grounding Guidelines, publication [1770-4.1](#).

For **Wiring and Installation Specifications**, see [page 5](#).

For **Certifications**, see [page 6](#).

For **Environmental Specifications**, see [page 6](#).

5069-OB16, 5069-OB16K, 5069-OB16F

Digital 16-point Sourcing Output Modules

Output Wiring - 5069-OB16, 5069-OB16K, 5069-OB16F

IMPORTANT:

- These modules do not draw current from the SA power bus. Still, the modules are DC-type modules, and you must install them on a DC SA power bus.
- The LA+ and LA- connections are used to supply field-side power to the module.

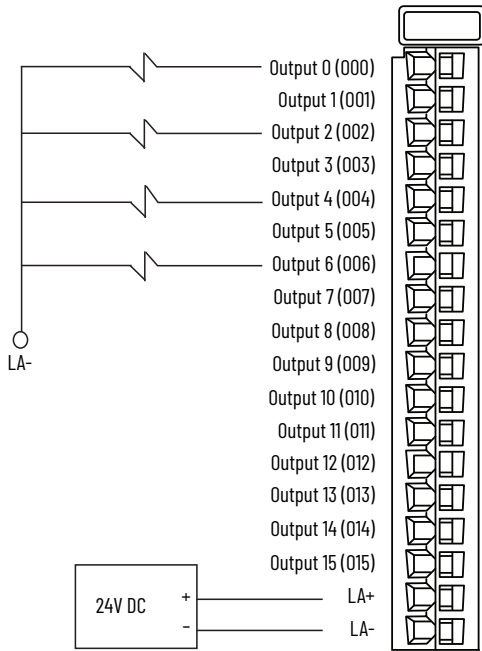

Functional Block Diagram - 5069-OB16, 5069-OB16K, 5069-OB16F

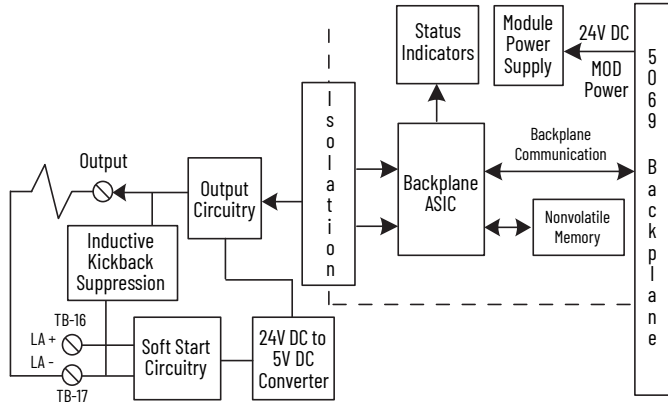

Technical Specifications - 5069-OB16, 5069-OB16K, 5069-OB16F

Attribute	5069-OB16, 5069-OB16K	5069-OB16F
Outputs	16 Channels (1 group of 16), sourcing	
Voltage category	12/24V DC source	
Voltage and current ratings		
MOD power	75 mA @ 18...32V DC	
MOD power (passthrough) ⁽¹⁾	9.55 A @ 18...32V DC	
LA Power	0.5 A per channel @ 10...32V DC 8 A per module @ 10...32V DC	
SA power (passthrough) ⁽¹⁾	9.95 A @ 10...32V DC NOTE: The module does not draw SA power current.	
Do not exceed 10 A MOD or SA power (passthrough) current draw		
Power dissipation, max	3.25 W (16 channels @ 0.5 A)	
Thermal dissipation, max	11.09 BTU/hr	

Technical Specifications - 5069-OB16, 5069-OB16K, 5069-OB16F

Attribute	5069-OB16, 5069-OB16K	5069-OB16F
Isolation voltage	250V (continuous), Basic Insulation Type No isolation between LA power and output ports No isolation between individual output ports	
Indicators	1 green/red module status indicator 16 yellow/red I/O status indicators	
Wire category ⁽²⁾	2 - output ports 2 - power ports 1 wire per terminal for each signal port	
LA power attributes		
On-state voltage, min	10V DC	
On-state voltage, nom	24V DC	
On-state voltage, max	32V DC	
On-state voltage drop, max	< 0.2V DC	
On-state current per channel, min	1 mA	
Off-state voltage, max	5V DC with 1 mA min load	
Off-state leakage current per point, max	< 0.5 mA per point NOTE: To limit the effects of leakage current through solid-state outputs, you can connect a loading resistor in parallel with your load. For 24V DC operation, use a 5.6 K Ω , 0.5 W resistor for transistor operation.	
Output current rating	0.5 A resistive per channel @ 10...32V DC 8 A resistive per module @ 10...32V DC, max	
Surge current per point	1 A max for 10 ms per point, repeatable every 2 s	
Output delay time (backplane to screw) Off to On and On to Off	$\leq 100 \mu\text{s}$, $\pm 10 \mu\text{s}$ @ 25 °C (77 °F) @ 0.5 A	10 μs , $\pm 1 \mu\text{s}$ @ 25 °C (77 °F) @ 0.5 A
Pulse width, min	200 μs @ 0.5 A @ 25 °C (77 °F)	20 μs @ 0.5 A @ 25 °C (77 °F)
Output drift over temperature span	$\pm 100 \text{ ns}/^\circ\text{C}$ (55.6 ns/ $^\circ\text{F}$) from 0...60 °C (32...140 °F) @ 0.5 A	$\pm 10 \text{ ns}/^\circ\text{C}$ (5.56 ns/ $^\circ\text{F}$) from 0...60 °C (32...140 °F) @ 0.5 A
Features, supported	The modules support these features. <ul style="list-style-type: none"> • Field power loss detection (Series B hardware only) • No load detection per channel diagnostics • Output short circuit/overload/overtemp detection per channel diagnostics • Output short circuit/overload protection • Reverse voltage protection 	
Overvoltage protection, max	36V (fuse protected)	
Pilot duty rating	0.5 A pilot duty rating per channel @ 10...32V DC	
Output control in fault state per point		
Output states in program mode per point	<ul style="list-style-type: none"> • Hold Last State • On • Off (default) 	
Output states in fault mode per point		
Duration of fault mode per point	<ul style="list-style-type: none"> • 1, 2, 5, or 10 seconds • Forever (default) 	
Scheduled outputs	-	$\pm 10 \mu\text{s}$ accuracy 1 ns resolution

(1) The level of Mod power or SA power current that passes through the module. This level depends on the system configuration, such as, module slot location and the other module types that are used in the system. For more information, see the controller user manuals in the [Additional Resources](#).

(2) Use this Conductor Category information to plan conductor routes. See the Industrial Automation Wiring and Grounding Guidelines, publication [1770-4.1](#).

For **Wiring and Installation Specifications**, see [page 5](#).
 For **Certifications**, see [page 6](#).
 For **Environmental Specifications**, see [page 6](#).

5069-0W4I

Digital 4-point Isolated Relay Output Module

Output Wiring - 5069-0W4I

IMPORTANT:

The 5069-0W4I module does not draw current from the SA power bus. Still, the module is a DC-type module, and you must install it on a DC SA power bus.

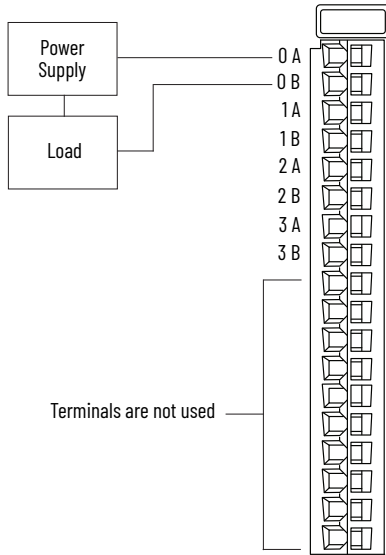

Functional Block Diagram - 5069-0W4I

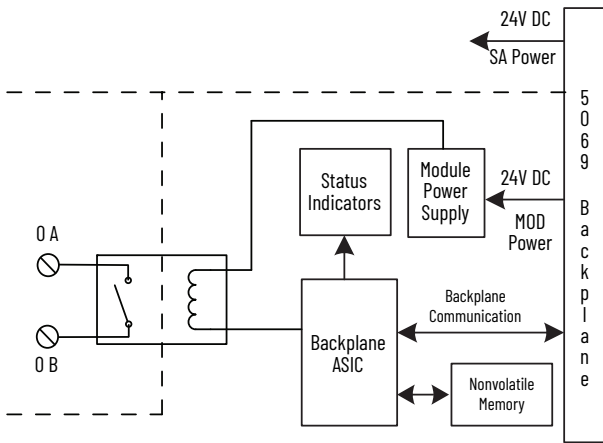

Technical Specifications - 5069-0W4I

Attribute	5069-0W4I
Outputs	4 - Form A (normally open)
Voltage and current ratings	
Output voltage range	5...125V DC 5...264V AC
MOD power	75 mA @ 18...32V DC
MOD power (passthrough) ⁽¹⁾	9.55 A @ 18...32V DC
SA power (passthrough) ⁽¹⁾	9.95 A @ 0...32V DC NOTE: The module does not draw SA power current.
Do not exceed 10 A MOD or SA power (passthrough) current draw	
Power dissipation, max	2.3 W
Thermal dissipation, max	7.85 BTU/hr
Isolation voltage	250V (continuous), Basic Insulation Type
Indicators	1 green/red module status indicator 4 yellow/red I/O status indicators

Technical Specifications - 5069-0W4I

Attribute	5069-0W4I
Wire category ⁽²⁾	1 - relay port 1 wire per terminal for each signal port
Relay rating	2 A resistive per channel @ 5...30V DC 2 A resistive per channel @ 5...264V AC, 50/60 Hz 2 A general use per channel @ 5...250V AC, 50/60 Hz 2 A @ 5...125V AC, UKEX/ATEX/IECEX 8 A per module, max NOTE: To extend the life of the module, connect surge suppressors across your external inductive load. For additional details, see the Industrial Automation Wiring and Grounding Guidelines, publication 1770-4.1 .
Off-state leakage	0 mA (dry contact, no onboard snubbers)
Output current rating, max	2 A per channel 8 A per module
Output delay time, max	
Off to On	10 ms
On to Off	10 ms
Switching frequency	1 operation every 3 seconds (0.3 Hz at rated load)
Initial contact resistance, max	30 mΩ
Bounce time, mean	500 μs
Output control in fault state per point	<ul style="list-style-type: none"> Hold last state On Off (default)
Output states in program mode per point	
Output states in fault mode per point	
Duration of fault mode per point	<ul style="list-style-type: none"> 1, 2, 5, or 10 seconds Forever (default)
Delay to fault	Supported
Fusing	Outputs are not fused.
Minimum load current	1 mA
Expected contact life	300K cycles resistive, 100K cycles inductive
Pilot duty rating	5...240V AC, 50/60 Hz, C300 pilot duty per channel 5...125V DC, R150 pilot duty per channel

- (1) The level of Mod power or SA power current that passes through the module. This level depends on the system configuration, such as, module slot location and the other module types that are used in the system. For more information, see the controller user manuals in the [Additional Resources](#) table.
- (2) Use this Conductor Category information to plan conductor routes. See the Industrial Automation Wiring and Grounding Guidelines, publication [1770-4.1](#).

Relay Contact Ratings - 5069-0W4I

Volts, Max	Continuous Amps per Point, Max	Amperes		Voltamperes		NEMA ICS 2-125
		Make	Break	Make	Break	
240V AC	2 A	7.5 A	0.75 A	1800VA	180VA	C300
120V AC		15 A	1.5 A			
125V DC	0.27 A ⁽¹⁾	0.22 A ⁽²⁾		28VA		R150
24V DC	2.0 A	1.16 A ⁽²⁾		28VA		-

- (1) Calculated based on the Rockwell Automation component derating guideline: 90% of rated contact current, that is, 0.3 A at 125V DC.
- (2) For DC voltage applications, to determine the make/break ampere rating for relay contacts, divide 28VA by the applied DC voltage. For example, 28VA/48V DC = 0.58 A.

For **Wiring and Installation Specifications**, see [page 7](#).
 For **Certifications**, see [page 8](#).
 For **Environmental Specifications**, see [page 8](#).

5069-0W16

Digital 16-point Relay Output Module

Output Wiring - 5069-0W16

IMPORTANT:

- The 5069-0W16 Series A and Series B modules require DC SA power. You must connect DC power to the device that supplies SA power to the module. See the [SA power device list](#) and [isolate SA power](#).
 - The 5069-0W16 Series C module does not use SA power. That is, it does not draw current from the SA power bus. The module passes it through to the next Compact 5000 I/O module in the system.
 - You can connect AC-type devices, DC-type devices, or a combination of the two types.
 - The module has two commons, each is shared across a set of eight output channels.
 - Common 0 is shared across Outputs 0...7
 - Common 1 is shared across Outputs 8...15
- Do not connect devices of different power types to channels that share a common.

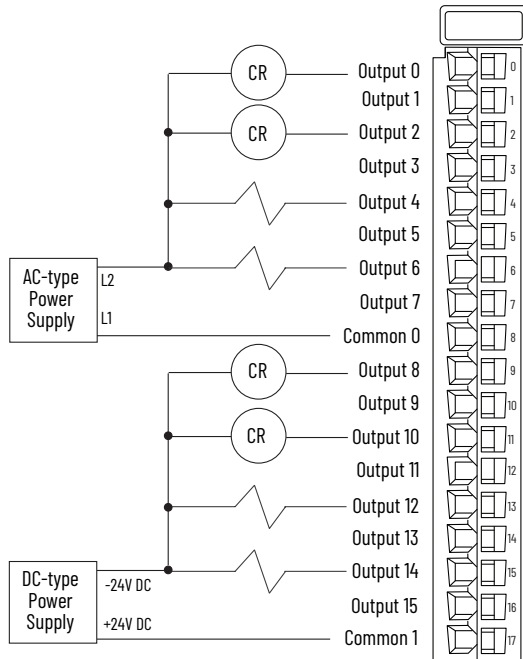

Functional Block Diagram - 5069-0W16 Series A and Series B

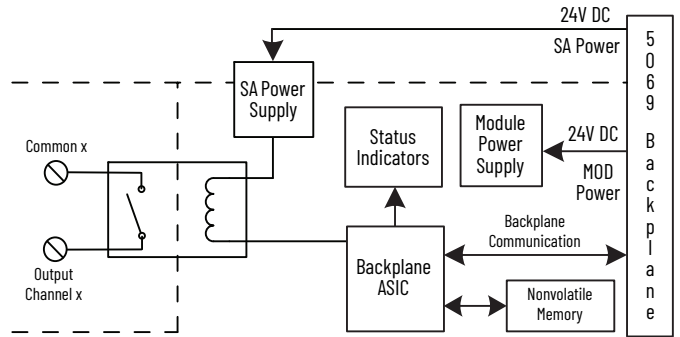

Functional Block Diagram - 5069-0W16 Series C

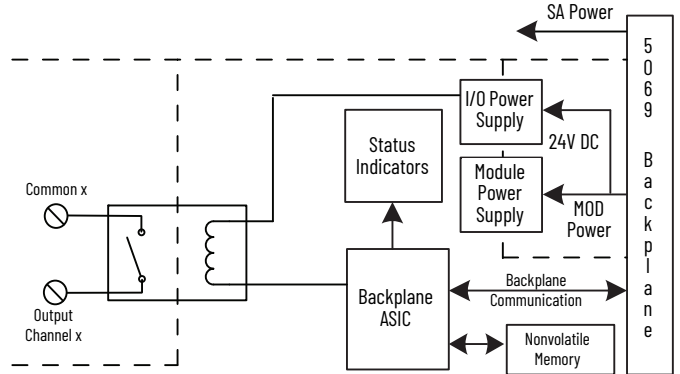

Technical Specifications - 5069-0W16

Attribute	5069-0W16
Outputs	16 (Two groups of 8) - Form A (normally open)
Voltage and current ratings	
Output voltage range	5...125V DC, 5...264V AC
MOD power	Series A and B: 75 mA @ 18...32V DC Series C: 225 mA @ 18...32V DC
MOD power (passthrough) ⁽¹⁾	9.95 A @ 18...32V DC
SA power	Series A and B: 150 mA @ 18...32V DC Series C: -
SA power (passthrough) ⁽¹⁾	9.95 A @ 18...32V DC
Do not exceed 10 A MOD or SA power (passthrough) current draw. The module complies with UKEX/ATEX/IECEX when used at or below 125V AC or 30V DC.	
Power dissipation, max	3.0 W
Thermal dissipation, max	10.2 BTU/hr
Isolation voltage	250V (continuous), Basic Insulation Type Type tested at 1800V AC for 60 s No isolation between individual channels
Module keying	Electronic keying via programming software
Indicators	1 green/red module status indicator 16 yellow/red I/O status indicators
Wire category ⁽²⁾	1 - relay port 1 - power port 1 wire per terminal for each signal port
Relay ratings	2 A resistive per channel @ 5...30V DC 2 A resistive per channel @ 5...264V AC, 50/60 Hz 2 A general use per channel @ 5...250V AC, 50/60 Hz 2 A @ 5...125V AC, UKEX/ATEX/IECEX NOTE: To extend the life of the module, connect surge suppressors across your external inductive load. For additional details, see the Industrial Automation Wiring and Grounding Guidelines, publication 1770-4.1 .
Off-state leakage current per point, max	Series A: 0 mA (dry contact, no onboard snubbers) Series B and Series C: 0 mA (with onboard TVS snubber)
Output current per group, max	8 A
Output current per module, max	16 A
Output delay time, max	
Off to On	10 ms
On to Off	10 ms
Switching frequency	1 operation every 3 seconds (0.3 Hz at rated load)
Initial contact resistance, max	30 mΩ
Bounce time, mean	500 μs

Technical Specifications - 5069-0W16

Attribute	5069-0W16
Delay to fault	Supported
Fusing	Outputs are not fused
Minimum load current	1 mA
Expected contact life	300K cycles resistive, 100K cycles inductive
Pilot duty rating	5...240V AC, 50/60 Hz, C300 pilot duty per channel 5...125V DC, R150 pilot duty per channel
Output control in fault state per point	<ul style="list-style-type: none"> Hold Last State On Off (default)
Output states in program mode per point	
Output states in fault mode per point	
Duration of fault mode per point	<ul style="list-style-type: none"> 1, 2, 5, or 10 seconds Forever (default)

- (1) The level of Mod power or SA power current that passes through the module. This level depends on the system configuration, such as, module slot location and the other module types that are used in the system. For more information, see the controller user manuals in the [Additional Resources](#) table.
- (2) Use this Conductor Category information to plan conductor routes. See the Industrial Automation Wiring and Grounding Guidelines, publication [1770-4.1](#).

Relay Contact Ratings - 5069-0W16

Volts, Max	Continuous Amps per Point, Max	Amperes		Voltamperes		NEMA ICS 2-125
		Make	Break	Make	Break	
240V AC	2 A	7.5 A	0.75 A	1800VA	180VA	C300
120V AC		15 A	1.5 A			
125V DC	0.27 A ⁽¹⁾	0.22 A ⁽²⁾		28VA		R150
24V DC	2.0 A	1.16 A ⁽²⁾		28VA		-

- (1) Calculated based on the Rockwell Automation component derating guideline: 90% of rated contact current, that is, 0.3 A at 125V DC.
- (2) For DC voltage applications, to determine the make/break ampere rating for relay contacts, divide 28VA by the applied DC voltage. For example, 28VA/48V DC = 0.58 A.

For **Wiring and Installation Specifications**, see [page 7](#).

For **Certifications**, see [page 8](#).

For **Environmental Specifications**, see [page 8](#).

5069-0X4I

Digital 4-point Isolated Normally-open/Normally-closed Output Module

Output Wiring - 5069-0X4I

IMPORTANT:

The module does not draw current from the SA power bus. Still, the module is a DC-type module, and you must install it on a DC SA power bus. See the [SA power device list](#) and [Isolate SA power](#).

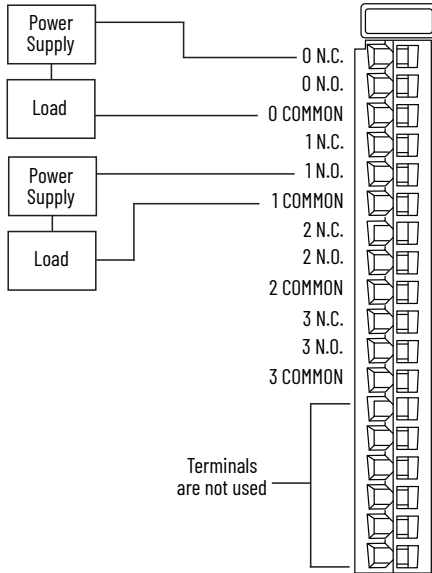

Functional Block Diagram - 5069-0X4I

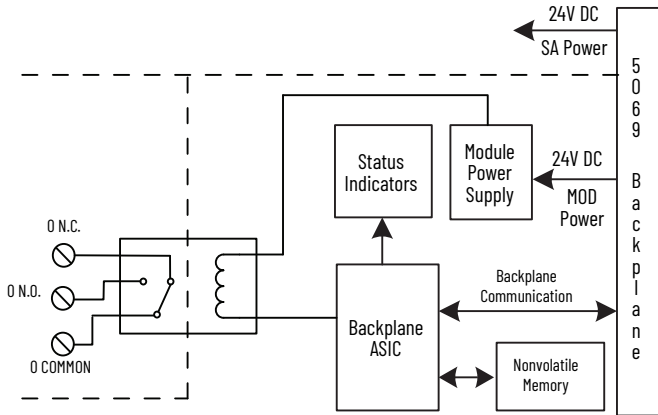

Technical Specifications - 5069-0X4I

Attribute	5069-0X4I
Outputs	4 - Form C (SPDT)
Voltage and current ratings	
Output voltage range	5...125V DC 5...264V AC
MOD power	75 mA @ 18...32V DC
MOD power (passthrough) ⁽¹⁾	9.55 A @ 18...32V DC
SA power (passthrough) ⁽¹⁾	9.95 A @ 0...32V DC NOTE: The module does not draw SA power current.
Do not exceed 10 A MOD or SA power (passthrough) current draw	
Power dissipation, max	2.6 W
Thermal dissipation, max	8.88 BTU/hr
Isolation voltage	250V (continuous), Basic Insulation Type
Indicators	1 green/red module status indicator 4 yellow/red I/O status indicators

Technical Specifications - 5069-0X4I

Attribute	5069-0X4I
Wire category ⁽²⁾	1 - relay port 1 - power port 1 wire per terminal for each signal port
Contact current rating	2 A resistive per channel @ 5...30V DC 2 A resistive per channel @ 5...264V AC, 50/60 Hz 2 A general use per channel @ 5...250V AC, 50/60 Hz 2 A @ 5...125V AC, UKEX/ATEX/IECEX 8 A per module, max NOTE: To extend the life of the module, connect surge suppressors across your external inductive load. For additional details, see the Industrial Automation Wiring and Grounding Guidelines, publication 1770-4.1 .
Off-state leakage	0 mA (dry contact, no onboard snubbers)
Output current rating	2 A per channel 8 A per module, max
Output delay time, max	
Off to On	15 ms
On to Off	15 ms
Switching frequency	1 operation every 3 seconds (.3 Hz at rated load)
Initial contact resistance, max	30 mΩ
Bounce time, mean	500 μs
Output control in fault state per point	<ul style="list-style-type: none"> Hold last state On Off (default)
Output states in program mode per point	<ul style="list-style-type: none"> Hold last state On Off (default)
Output states in fault mode per point	<ul style="list-style-type: none"> Hold last state On Off (default)
Duration of fault mode per point	<ul style="list-style-type: none"> 1, 2, 5, or 10 seconds Forever (default)
Delay to fault	Supported
Fusing	Outputs are not fused
Minimum load current	10 mA
Expected contact life	300K cycles resistive, 100K cycles inductive
Pilot duty rating	5...240V AC, 50/60 Hz, C300 pilot duty per channel 5...125V DC, R150 pilot duty per channel

(1) The level of Mod power or SA power current that passes through the module. This level depends on the system configuration, such as, module slot location and the other module types that are used in the system. For more information, see the controller user manuals in the [Additional Resources](#) table.

(2) Use this Conductor Category information to plan conductor routes. See the Industrial Automation Wiring and Grounding Guidelines, publication [1770-4.1](#).

Relay Contact Ratings - 5069-0X4I

Volts, Max	Continuous Amps per Point, Max	Amperes		Voltamperes		NEMA ICS 2-125
		Make	Break	Make	Break	
240V AC	2 A	7.5 A	0.75 A	1800VA	180VA	C300
120V AC		15 A	1.5 A			
125V DC	0.225 A ⁽¹⁾	0.22 A ⁽²⁾		28VA		R150
24V DC	2.0 A	1.16 A ⁽²⁾		28VA		-

(1) Calculated based on the Rockwell Automation component derating guideline: 90% of rated contact current, that is, 0.25 A at 125V DC.

(2) For DC voltage applications, to determine the make/break ampere rating for relay contacts, divide 28VA by the applied DC voltage. For example, 28VA/48V DC = 0.58 A.

For **Wiring and Installation Specifications**, see [page 7](#).
 For **Certifications**, see [page 8](#).
 For **Environmental Specifications**, see [page 8](#).

Analog I/O Modules

For information that applies to all of the analog I/O modules, see these tables.

- [Wiring and Installation Specifications - Analog I/O Modules](#)
- [Certifications - Analog I/O Modules](#)
- [Environmental Specifications - Analog I/O Modules](#)

The following analog I/O modules are available.

I/O Type	Cat. No.	Description	Page
Analog input	5069-IF4IH	4-channel isolated current/voltage/HART input module	19
	5069-IF8	8-channel current/voltage input module	21
	5069-IY4	4-channel current/voltage/RTD/Thermocouple input module	23
	5069-IY4K	4-channel conformal coated current/voltage/RTD/Thermocouple input module	
Analog output	5069-OF4IH	4-channel isolated current/voltage/HART output module	27
	5069-OF4	4-channel current/voltage output module	29
	5069-OF4K	4-channel conformal coated current/voltage output module	
	5069-OF8	8-channel current/voltage output module	

Wiring and Installation Specifications - Analog I/O Modules

Attribute	5069-IF4IH, 5069-IF8, 5069-IY4, 5069-IY4K, 5069-OF4, 5069-OF4K, 5069-OF4IH, 5069-OF8
Channel connections	The wiring diagrams show specific devices that are connected to specific channels. You are not restricted to using only those devices or channels. You can connect devices to any channel or combination of channels as needed.
Loop devices on a current loop	Place additional loop devices, for example, strip chart recorders, at either "A" location in a current loop.
SA power	<ul style="list-style-type: none"> • The analog I/O modules uses DC SA power. You must connect DC power to the device that supplies SA power to the module. • Use separate external power supplies to provide SA power to the system and to power external devices that are connected to the module.
Ground devices	<ul style="list-style-type: none"> • The analog I/O modules have two shield terminals. Compact 5000 I/O module RTBs only support one wire per terminal, so you can ground two devices at the module shield terminals. • For remaining devices, ground them somewhere else, like the DIN rail via a terminal strip. <p>If separate power supplies are used to power the additional devices, ground the power supplies at the same ground location.</p>
SA power device list	<p>Connections to an external power supply that provides SA power via the SA power RTB on one of these devices.</p> <ul style="list-style-type: none"> • CompactLogix 5380 controller • Compact GuardLogix 5380 controller • CompactLogix 5480 controller • 5069-AENTR EtherNet/IP Adapter • 5069-FPD field potential distributor
Isolate SA power	<p>If you install modules in a system that uses both AC SA power and DC SA power, you must isolate SA power buses by type with a 5069-FPD field potential distributor. To create separate SA power buses, complete these steps.</p> <ol style="list-style-type: none"> 1. Install the modules that use one type of SA power, for example DC, to the right of the adapter or controller. This is the first SA power bus. 2. To create a second SA power bus, install the 5069-FPD field module to the right of these modules. 3. Install the modules that use the other type of SA power, for example AC, to the right of the 5069-FPD module.
Slot width	1
Dimensions (HxWxD)	144.57 x 22 x 105.42 mm (5.69 x 0.87 x 4.15 in.)
Weight, approx	175 g (0.39 lb)
DIN rail	Compatible zinc-plated chromate-passivated steel DIN rail. You can use the EN50022 - 35 x 7.5 mm (1.38 x 0.30 in.) DIN rail.
Module keying	Electronic keying via programming software
RTB	5069-RTB18-SPRING RTB or 5069-RTB18-SCREW RTB If at least one thermocouple is connected to the 5069-IY4 or 5069-IY4K modules, you must use the 5069-RTB14CJC-SPRING RTB or 5069-RTB14CJC-SCREW RTB. NOTE: RTBs do not ship with Compact 5000™ I/O modules, you must order them separately. Order only the RTB type that your system requires.
RTB torque	Screw-type RTB only: 0.4 N•m (3.5 lb•in)
RTB keying	None
Wire size	0.5...1.5 mm ² (22...16 AWG) solid or stranded shielded copper wire rated at 105 °C (221 °F) or greater 5069-RTB18-SPRING RTB: 2.9 mm (0.11 in.) max diameter including insulation, single wire connection only. 5069-RTB18-SCREW RTB: 3.5 mm (0.14 in.) max diameter including insulation, single wire connection only. For the 5069-OW16 module only: Use minimum 18 AWG, 105 °C (221 °F) rated wire for load connections to relay output modules.
Insulation-stripping length	5069-RTB18-SPRING RTB: 10 mm (0.39 in.) 5069-RTB18-SCREW RTB: 12 mm (0.47 in.)

Environmental Specifications - Analog I/O Modules

Attribute	5069-IF4IH, 5069-IF8, 5069-IY4, 5069-IY4K, 5069-OF4, 5069-OF4K, 5069-OF4IH, 5069-OF8
Temperature, operating IEC 60068-2-1 (Test Ad, Operating Cold) IEC 60068-2-2 (Test Bd, Operating Dry Heat) IEC 60068-2-14 (Test Nb, Operating Thermal Shock)	0...60 °C (32...140 °F)
Temperature, surrounding air, max	60 °C (140 °F)
Temperature, nonoperating IEC 60068-2-1 (Test Ab, Unpackaged Nonoperating Cold) IEC 60068-2-2 (Test Bb, Unpackaged Nonoperating Dry Heat) IEC 60068-2-14 (Test Na, Unpackaged Nonoperating Thermal Shock)	-40...+85 °C (-40...+185 °F)
Relative humidity IEC 60068-2-30 (Test Db, Unpackaged Damp Heat)	5...95% noncondensing
Vibration IEC 60068-2-6 (Test Fc, Operating)	5 g @ 10...500 Hz
Shock, operating IEC 60068-2-27 (Test Ea, Unpackaged Shock)	30 g
Shock, nonoperating IEC 60068-2-27 (Test Ea, Unpackaged Shock)	50 g
Emissions	IEC 61000-6-4
ESD immunity IEC 61000-4-2	6 kV contact discharges 8 kV air discharges
Radiated RF immunity IEC 61000-4-3	10V/m with 1 kHz sine wave 80% AM from 80...6000 MHz
EFT/B immunity IEC 61000-4-4	±4 kV @ 5 kHz on power ports ±3 kV @ 5 kHz on input ports
Surge transient immunity IEC 61000-4-5	±1 kV line-line (DM) and ±2 kV line-earth (CM) on power ports ±2 kV line-earth (CM) on shielded input ports
Conducted RF immunity IEC 61000-4-6	10V rms with 1 kHz sine wave 80% AM from 150 kHz...80 MHz
Voltage variation IEC 61000-4-29	10 ms interruption on MOD power port
North American temp code	T4
UKEX/ATEX temp code	T4
IECEX temp code	T4
Enclosure type	None (open-style)

Certifications - Analog I/O Modules

Certification	5069-IF4IH, 5069-IF8, 5069-IY4, 5069-IY4K, 5069-OF4, 5069-OF4K, 5069-OF4IH, 5069-OF8
c-UL-us	UL Listed Industrial Control Equipment, certified for US and Canada. See UL File E322657. UL Listed for Class I, Division 2 Group A,B,C,D Hazardous Locations, certified for U.S. and Canada. See UL File E334470.
UKCA and CE	UK Statutory Instrument 2016 No. 1091 and European Union 2014/30/EU EMC Directive, compliant with: EN 61326-1; Meas./Control/Lab., Industrial Requirements EN 61000-6-2; Industrial Immunity EN 61000-6-4; Industrial Emissions EN 61131-2; Programmable Controllers (Clause 8, Zone A & B) UK Statutory Instrument 2016 No. 1101 and European Union 2014/35/EU LVD, compliant with: EN 61010-2-201; Control Equipment Safety Requirements UK Statutory Instrument 2012 No. 3032 and European Union 2011/65/EU RoHS, compliant with: EN IEC 63000; Technical documentation
RCM	Australian Radiocommunications Act, compliant with EN 61000-6-4; Industrial Emissions
Ex	UK Statutory Instrument 2016 No. 1107 and European Union 2014/34/EU ATEX Directive, compliant with: EN IEC 60079-0; General Requirements EN IEC 60079-7; Explosive Atmospheres, Protection "e" II 3 G Ex ec IIC T4 Gc DEMKO 15 ATEX 1484X and UL22UKEX2379X
IECEX	IECEX System, compliant with: IEC 60079-0; General Requirements IEC 60079-7; Explosive Atmospheres, Protection "e" II 3 G Ex ec IIC T4 Gc IECEX UL 15.0055X
KC	Korean Registration of Broadcasting and Communications Equipment, compliant with Article 58-2 of Radio Waves Act, Clause 3
Morocco	Arrêté ministériel n° 6404-15 du 1er muharram 1437 Arrêté ministériel n° 6404-15 du 29 ramadan 1436
CCC	CNCA-C23-01:2019强制性产品认证实施规则 防爆电气 CNCA-C23-01:2019 CCC Implementation Rule Explosion-Proof Electrical Products CCC: 2020312309000308

See the Product Certification link at rok.auto/certifications for Declarations of Conformity, Certificates, and other certification details.

5069-IF4IH

4-channel isolated current/voltage/HART input module

The 5069-IF4IH module supports a differential signal and these device modes.

Device	Supported Modes
2-wire analog device	Current
4-wire analog device ⁽¹⁾	Voltage
	Combination of current and voltage

The channel configuration in your Logix Designer application project must match the input device type that is connected to the channel. Select the input type on the Channels tab in the Module Properties. For example, if a current input device is connected to a channel, the configuration for the channel must be Input Type = Current.

(1) The 4-wire analog devices are 2-wire current and voltage devices with 2-wire sensor power connections.

IMPORTANT: This module does not support the use of the voltage input and current input terminals on the same channel at the same time.

Current Devices Input Wiring - 5069-IF4IH

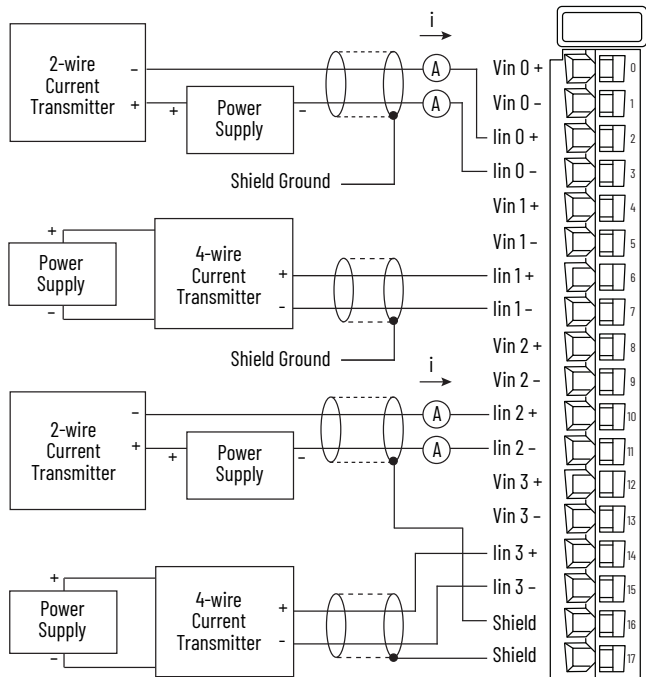

Voltage Devices Input Wiring - 5069-IF4IH

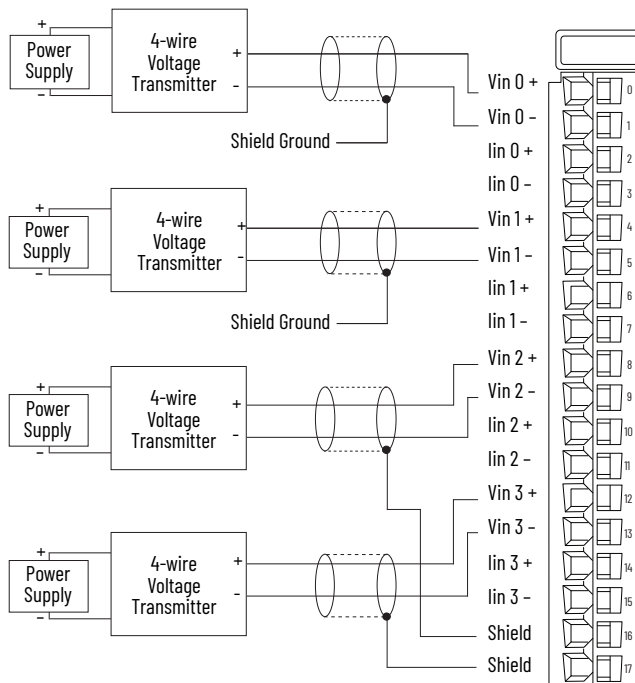

Combination of Current and Voltage Devices Input Wiring - 5069-IF4IH

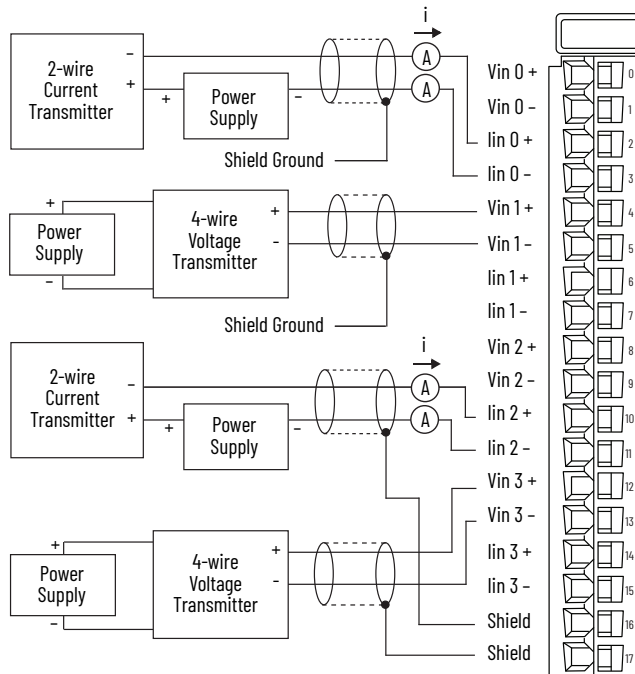

Functional Block Diagram - 5069-IF4IH Current or HART Mode

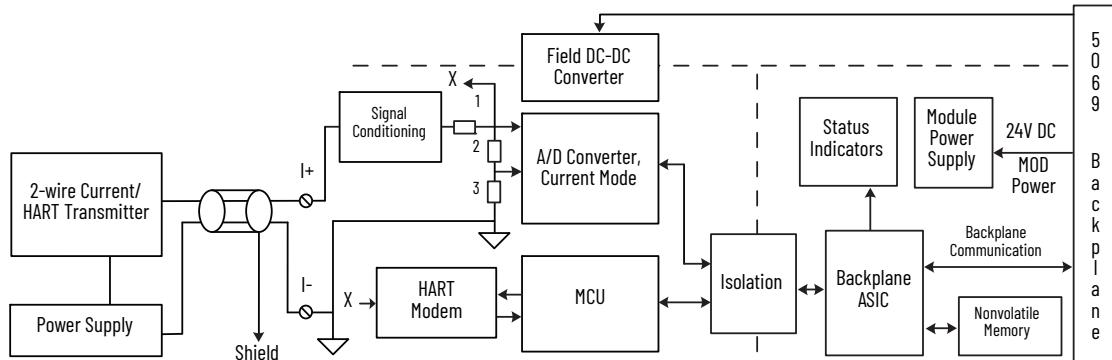

Functional Block Diagram - 5069-IF4IH Voltage Mode

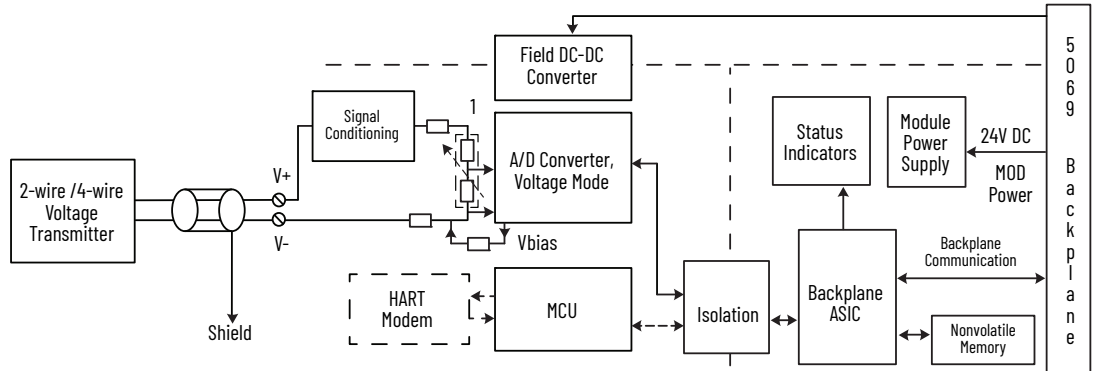

Technical Specifications - 5069-IF4IH

Attribute	Value
Inputs	4 individually isolated
Input range, voltage	±10V 0...10V 0...5V
Input range, current	0...20 mA 4...20 mA (HART)
Voltage and current ratings	
Analog input ratings	0...20 mA, +/-10V DC (per channel)
MOD power	75 mA @ 18...32V DC
MOD power (passthrough) ⁽¹⁾	9.55 A @ 18...32V DC
SA power	50 mA @ 18...32V DC
SA power (passthrough) ⁽¹⁾	9.95 A @ 18...32V DC
Power dissipation, max	Voltage and Current mode: 4.0 W
Thermal dissipation, max	Voltage and Current mode: 11.3 BTU/hr
Isolation voltage	250V (continuous), Basic Insulation Type, • SA to: Channel, FE, MP, or System • MP to: Channel or FE • System to: Channel, FE, or MP • Channel to: Channel or FE
Calibration methods	Factory calibrated User-performed (optional)
Indicators	1 green/red module status indicator 4 yellow/red I/O status indicator
Normal mode noise rejection ratio	65 dB @ 50/60 Hz, notch filter dependent
Wire category ⁽²⁾	2 - shielded input ports 1 wire per terminal for each signal port
Input impedance	Voltage mode: >1 MΩ Current mode: 250 Ω typical
Module conversion method	Sigma-Delta, Two 24-bit multiplexed ADC
Effective resolution, voltage ⁽¹⁾ (At 60 Hz notch filter)	±10V: 18 bits 0...10V: 17 bits 0...5V: 16 bits
Effective resolution, current ⁽¹⁾ (At 60 Hz notch filter)	0...20 mA: 17 bits 4...20 mA: 17 bits
Calibrated accuracy at 77 °F (25 °C)	Voltage and Current Mode: HART enabled, typical values: 0.12% full scale with 10 Hz filter 0.20% full scale with 60 Hz filter 0.05% full scale with 60 Hz filter 0.28% full scale with 100 Hz filter 0.32% full scale with 200 Hz filter 0.65% full scale with 500 Hz filter
Calibrated accuracy over temperature range of 32...140 °F (0...60 °C)	Voltage and Current Mode: HART enabled, typical values: 0.17% full scale with 10 Hz filter 0.25% full scale with 60 Hz filter 0.10% full scale with 60 Hz filter 0.33% full scale with 100 Hz filter 0.36% full scale with 200 Hz filter 0.70% full scale with 500 Hz filter

Technical Specifications - 5069-IF4IH

Attribute	Value
HART scan time	1 s typical These items can increase the update time significantly: • Additional device variables • Configured commands • Pass through messages • Handheld communicators • Secondary masters • Communication errors • Configuration changes
Scan Time at 10 kHz notch	Per channel: 2 ms Per group: 2 ms
Notch filter at minimum RPI (0.2 ms, 1 channel enabled)	10 kHz
Minimum notch filter with RPI of 2.5 ms	500 Hz
Input notch filter (Hz) selections	HART mode: 5, 10 (50/60 Hz simultaneous rejection), 15, 20, 50, 60, 100, 200, 500 Voltage and Current modes: 5, 10 (50/60 Hz simultaneous rejection), 15, 20, 50, 60, 100, 200, 500, 1000, 2500, 5000, 10000
Recommended RPI for 200 Hz notch filter with HART enabled	7 ms
Input digital filter	First order lag, 0 ms (Default)...32,767 ms (32,767 s)
Overvoltage protection, max	Voltage and Current modes: ± 32V DC
Overcurrent protection, max	Current mode: ±30 mA
Data value during overload condition	Full scale, overrange flag, underrange, Data uncertain/data bad
Data value during overrange condition	Voltage mode: 10.7V (+/- 10V, 0...10V), 5.35V (0...5V) Current mode: 23 mA (0...20 mA, 4...20 mA)
Data value during underrange condition	Voltage mode: -10.7V (+/- 10V), -0.041V (0...10V), -0.021V (0...5V) Current Mode: 0.11 mA (0...20 mA), 3mA (4...20 mA)
Open circuit detection time ⁽³⁾	Voltage mode: + full scale, < 2 s Current mode: 4...20 mA range, < 1 s
Features, supported	The module supports these features. • Onboard data alarming • Scaling to engineering units • Real-time channel sampling • Input time stamps • CIP Sync
Data format	IEEE 32-bit floating point

(1) The level of Mod power or SA power current that passes through the module. This level depends on the system configuration, such as, module slot location and the other module types that are used in the system. For more information, see the controller user manuals in the [Additional Resources](#).

(2) Use this Conductor Category information to plan conductor routes. See the Industrial Automation Wiring and Grounding Guidelines, publication [1770-4.1](#).

(3) Notch filter dependent.

For **Wiring and Installation Specifications**, see [page 17](#).

For **Certifications**, see [page 18](#).

For **Environmental Specifications**, see [page 18](#).

5069-IF8

Analog 8-channel Current/Voltage Input Module

The following table lists the supported device modes.

Device	Supported Modes
2-wire analog device	Current
3-wire analog device	Voltage
4-wire analog device ⁽¹⁾	Combination of current and voltage

The channel configuration in your Logix Designer application project must match the input device type that is connected to the channel. Select the input type on the Channels tab in the Module Properties. For example, if a current input device is connected to a channel, the configuration for the channel must be Input Type = Current.

(1) The 4-wire analog devices are 2-wire current and voltage devices with 2-wire sensor power connections.

Input Wiring - 5069-IF8 Series B

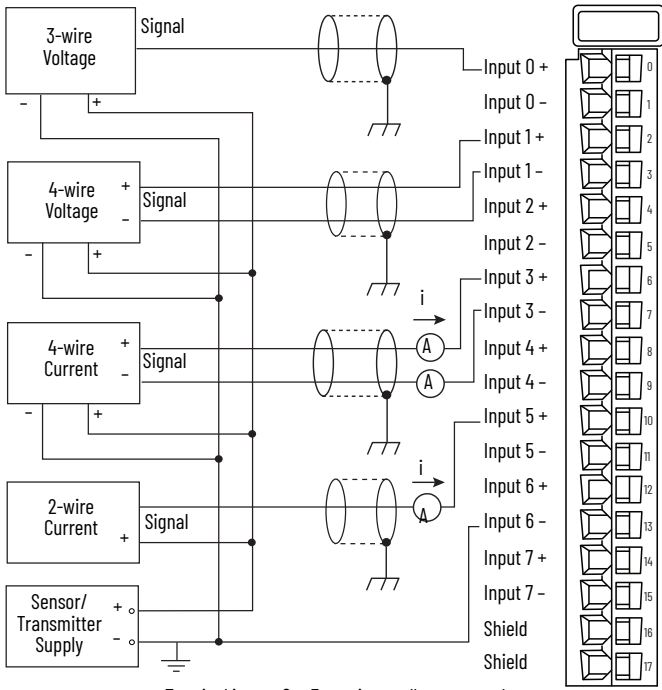

Input Wiring - 5069-IF8 Series A

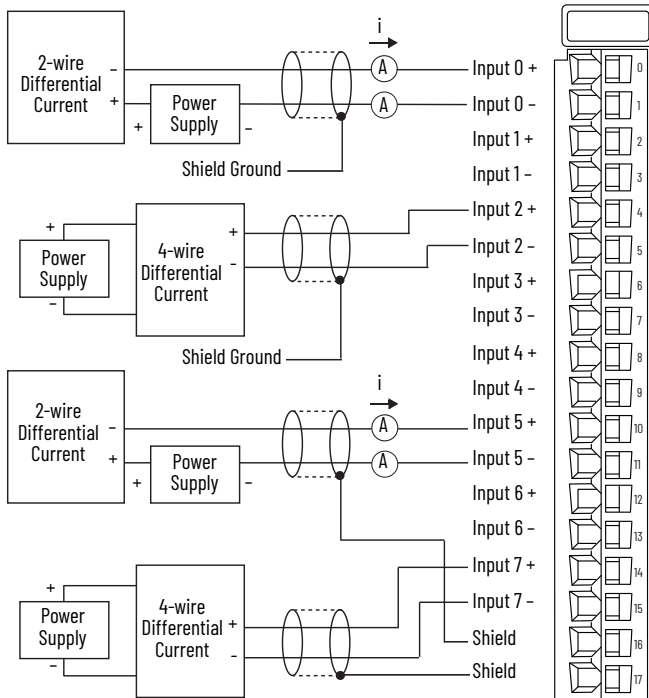

Functional Block Diagram - 5069-IF8 Series B

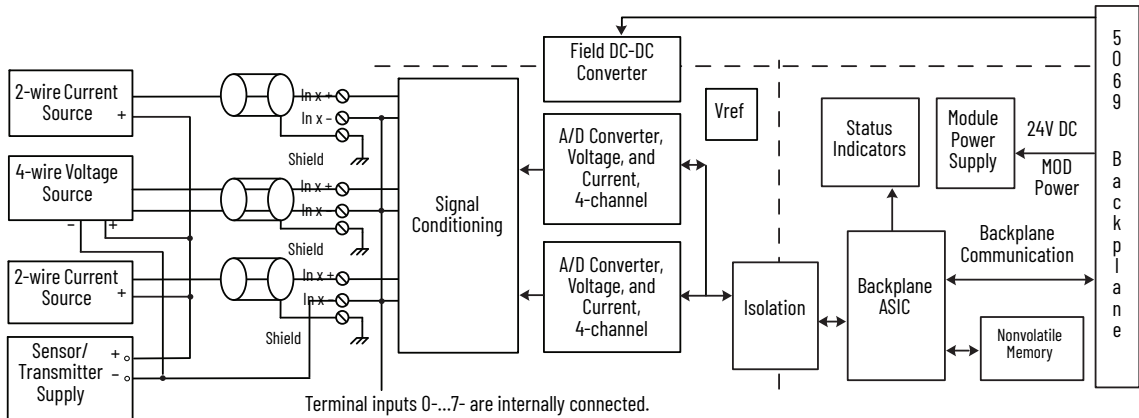

Functional Block Diagram - 5069-IF8 Series A

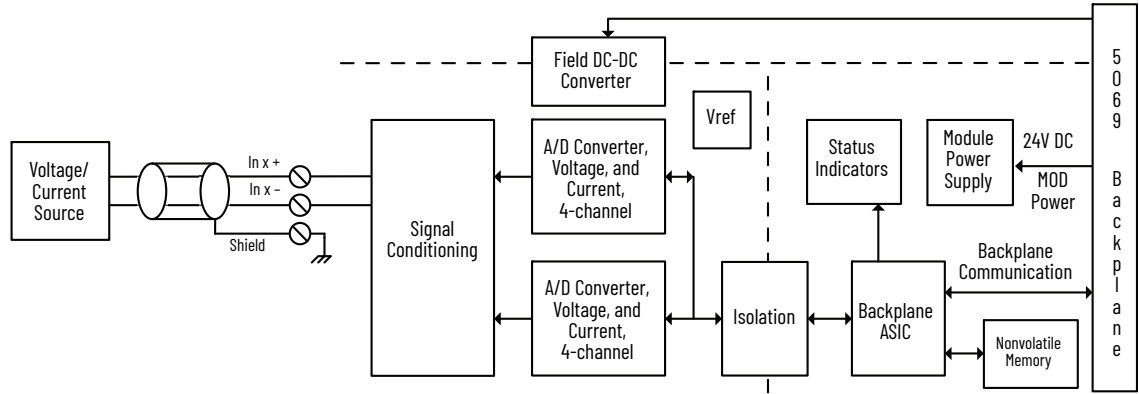

Technical Specifications - 5069-IF8

Attribute	5069-IF8
Inputs	Series A: 8 differential Series B: 8 single-ended
Input range, voltage	±10V 0...10V 0...5V
Input range, current	0...20 mA 4...20 mA
Voltage and current ratings	
MOD power	75 mA @ 18...32V DC
MOD power (passthrough) ⁽¹⁾	9.55 A @ 18...32V DC
SA power	100 mA @ 18...32V DC
SA power (passthrough) ⁽¹⁾	9.95 A @ 18...32V DC
Do not exceed 10 A MOD or SA power (passthrough) current draw.	
Power dissipation, max	Voltage mode: 2.1 W Current mode: 2.4 W
Thermal dissipation, max	Voltage mode: 7.2 BTU/hr Current mode: 8.2 BTU/hr
Isolation voltage	250V (continuous), Basic Insulation Type 50V Functional Isolation between SA power and input ports No isolation between individual Input ports
Calibration methods	Factory calibrated User calibration is optional
Indicators	1 green/red module status indicator 8 yellow/red I/O status indicator
Common mode noise rejection ratio	130 dB @ 50/60 Hz
Normal mode noise rejection ratio	65 dB @ 50/60 Hz, notch filter dependent
Wire category ⁽²⁾	2 - shielded input ports 1 wire per terminal for each signal port
Input impedance	Voltage: >1 MΩ Current: 90 Ω typical, 70...110 Ω range
Common mode voltage (channel to channel)	Series A: ±10V (Current mode) ±2V (Voltage mode) Series B: -
Module conversion method	Sigma-Delta, Two 24-bit multiplexed ADC
Resolution, voltage ⁽³⁾ (16 bits at 10 Hz notch filter)	±10.5V: <320 μV/count (15 bits plus sign bipolar) 0...10.5V: <160 μV/count (16 bits unipolar) 0...5.25V: <80 μV/count (16 bits unipolar)
Resolution, current ⁽³⁾ (16 bits at 10 Hz notch filter)	0...21 mA: <0.32 μA/count (16 bits) 3.6...21 mA: <0.27 μA/count (16 bits)
Calibrated accuracy at 77 °F (25 °C)	Voltage 0.10% full scale Current 0.10% full scale
Accuracy drift with temperature	Voltage 0.20% full scale Current 0.30% full scale

Technical Specifications - 5069-IF8

Attribute	5069-IF8
Input Total Unadjusted Error (TUE) (Over full temperature range)	Voltage 0.30% full scale Current 0.40% full scale NOTE: Includes offset, gain, non-linearity, and repeatability error terms.
Scan Time Per channel Per group (channel group 0...3 or channel group 4...7)	625 μs 2.5 ms
Notch filter at minimum RPI (0.2 ms, 1 channel enabled)	62.5 kHz
Minimum notch filter frequency at RPI of 2.5 ms	10 kHz
Step response time to 63% of value (Notch filter 10 kHz)	7.5 ms
Input notch filter (Hz) selections	5, 10 (50/60 Default), 15, 20, 50, 60, 100, 200, 500, 1000, 2500, 5000, 10000, 15625, 25000, 31250, 62500
Input anti-aliasing filter cutoff frequency, nom	500 Hz
Input digital filter	First order lag, 0 ms (Default)...32,767 ms (32.767 s)
HART handheld compliance	Add an external 250 Ω resistor into the current loop for HART transmitter compliance.
Overvoltage protection, max	Voltage and Current modes: ± 30V DC
Overcurrent protection, max	Current mode: ±30 mA
Data value during overload condition	Full scale, overrange flag, Data uncertain/data bad
Open circuit detection time	Voltage: + full scale, < 2 s Current: 4...20 mA range, < 2 s
Features, supported	The module supports these features. • Onboard data alarming • Scaling to engineering units • Real-time channel sampling
Data format	IEEE 32-bit floating point

- (1) The level of Mod power or SA power current that passes through the module. This level depends on the system configuration, such as, module slot location and the other module types that are used in the system. For more information, see the controller user manuals in the [Additional Resources](#).
- (2) Use this Conductor Category information to plan conductor routes. See the Industrial Automation Wiring and Grounding Guidelines, publication [1770-4.1](#).
- (3) Notch filter dependent.

For **Wiring and Installation Specifications**, see [page 17](#).

For **Certifications**, see [page 18](#).

For **Environmental Specifications**, see [page 18](#).

5069-IY4 and 5069-IY4K

Analog Input Modules

The following table lists the analog devices that are supported.

Device	Supported Modes	Wiring Diagram Example Page
1-wire analog device 2-wire analog device 4-wire analog device ⁽¹⁾	Current	23
	Voltage	
	Any combination of current, voltage, RTD, Thermocouple	
2-wire RTD device 3-wire RTD device	RTD	24
	Any combination of current, voltage, RTD, Thermocouple	24
2-wire Thermocouple device	Thermocouple	24
	Any combination of current, voltage, RTD, Thermocouple	24

- The channel configuration in your Logix Designer application project must match the input device type that is connected to the channel. Select the input type on the Channels tab in the Module Properties. For example, if a current input device is connected to a channel, the configuration for the channel must be Input Type = Current.
 - If at least one thermocouple is connected to the module, you must use the 5069-RTB14CJC RTB.
- (1) The 4-wire analog devices are 2-wire current and voltage devices with 2-wire sensor power connections.

Current and Voltage Devices with Single-ended Transmitter Inputs Wiring - 5069-IY4, 5069-IY4K

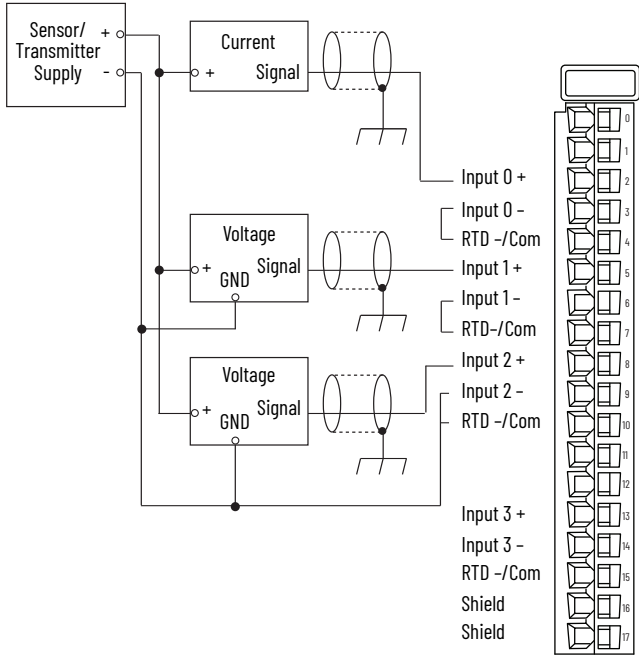

Current and Voltage Devices with Mixed Transmitter Inputs Wiring - 5069-IY4, 5069-IY4K

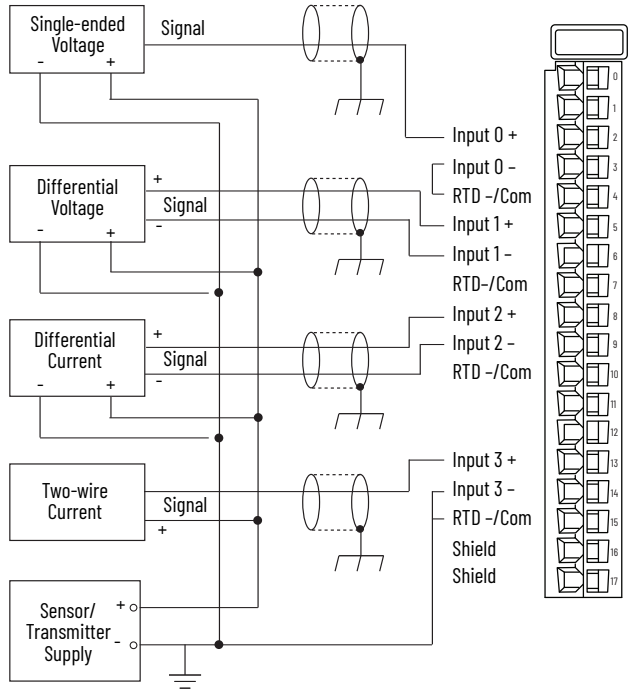

RTD Devices with Three Wires Input Wiring - 5069-IY4, 5069-IY4K

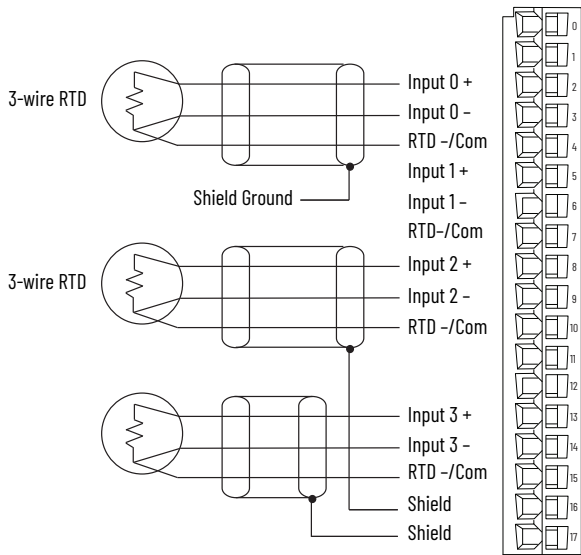

RTD Devices with Two Wires Input Wiring - 5069-IY4, 5069-IY4K

IMPORTANT: When you use a 2-wire RTD in 3-wire mode, you must jumper terminals Input x- and RTD x together.

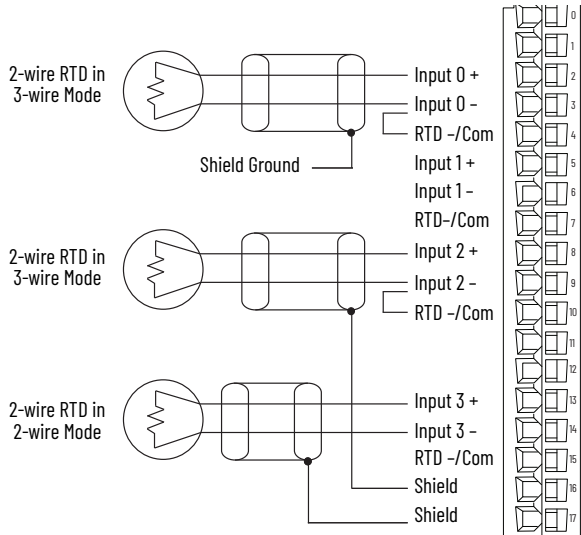

Current, Voltage, and RTD Devices Input Wiring - 5069-IY4, 5069-IY4K

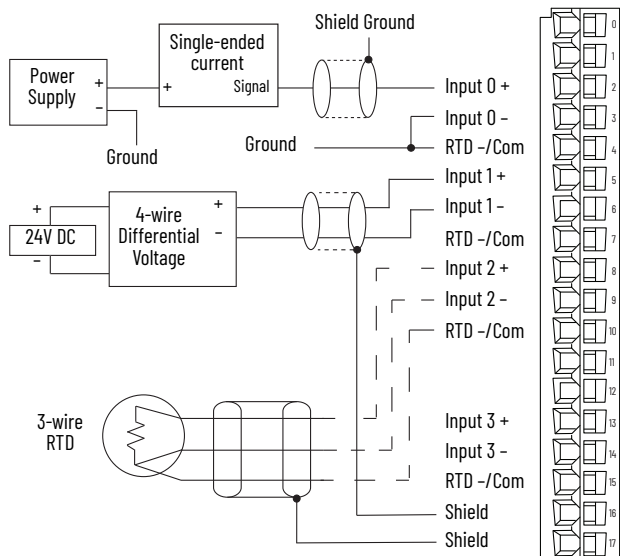

Thermocouple Device Input Wiring - 5069-IY4, 5069-IY4K

IMPORTANT: When you connect at least one Thermocouple to the module, you must use a 5069-RTB14CJC RTB.

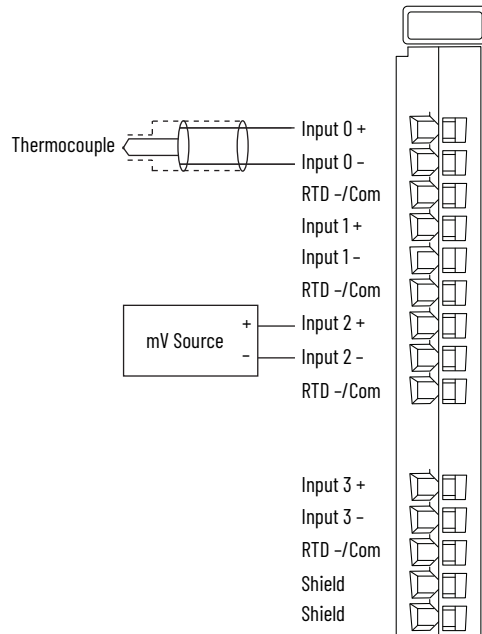

Current, Voltage, RTD, and Thermocouple Devices Input Wiring - 5069-IY4, 5069-IY4K

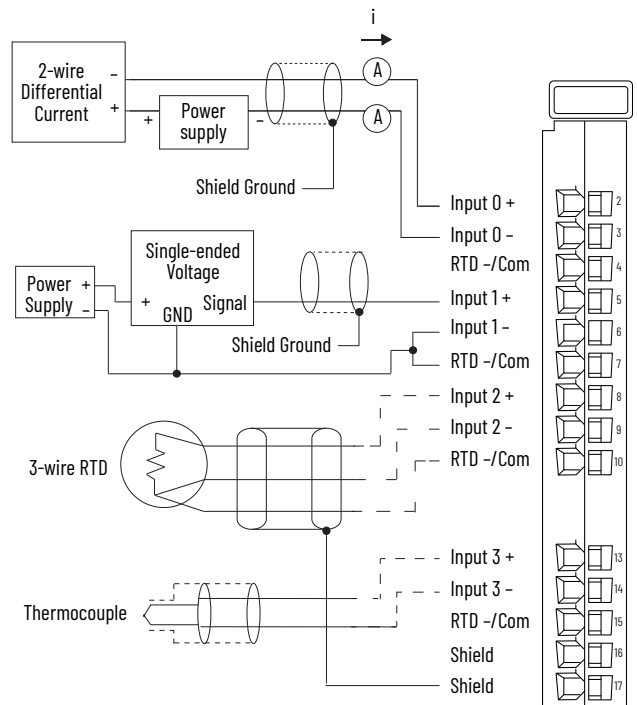

Functional Block Diagram - 5069-IY4, 5069-IY4K
Current Mode, Voltage Mode, and Mixed Transmitter Inputs

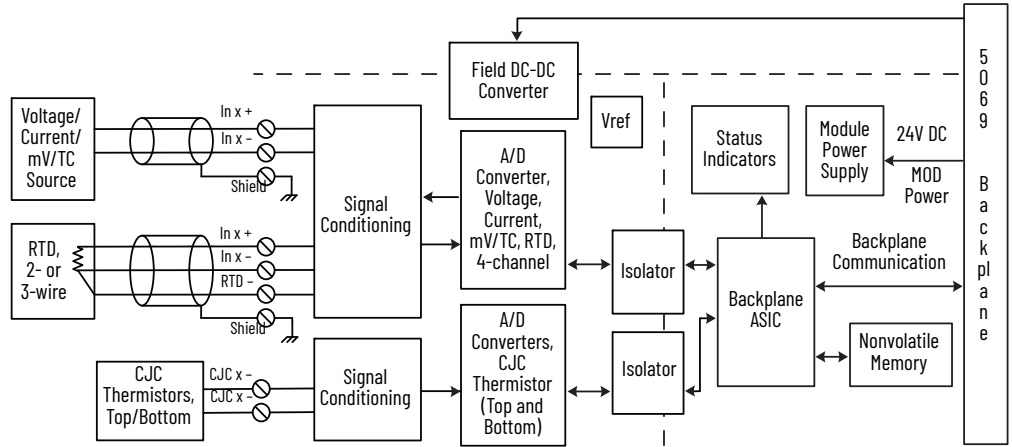

Technical Specifications - 5069-IY4, 5069-IY4K

Attribute	5069-IY4, 5069-IY4K
Inputs	4 differential
Input range, voltage	±10V 0...10V 0...5V
Input range, current	0...20 mA 4...20 mA
Voltage and current ratings	
MOD power	75 mA @ 18...32V DC
MOD power (passthrough) ⁽¹⁾	9.55 A @ 18...32V DC
SA power	100 mA @ 18...32V DC
SA power (passthrough) ⁽¹⁾	9.95 A @ 18...32V DC
Do not exceed 10 A MOD or SA power (passthrough) current draw	
Power dissipation, max	Voltage mode: 1.8 W Current mode: 2.1 W RTD mode: 2.1 W Thermocouple / millivolt mode: 1.8 W
Thermal dissipation, max	Voltage mode: 6.1 BTU/hr Current mode: 7.2 BTU/hr RTD mode: 7.2 BTU/hr Thermocouple/millivolt: 6.1 BTU/hr
Isolation voltage	250V (continuous), Basic Insulation Type 50V Functional Isolation between SA power and input ports No isolation between individual input ports
Calibration methods	Factory calibrated User-performed (optional)
Indicators	1 green/red module status indicator 4 yellow/red I/O status indicators 2 yellow/red CJC status indicators
Noise rejection ratio	Common mode - 130 dB @ 50/60 Hz Normal mode - 65 dB @ 50/60 Hz, notch filter dependent
Wire category ⁽²⁾	2 - shielded input ports 1 wire per terminal for each signal port

Technical Specifications - 5069-IY4, 5069-IY4K

Attribute	5069-IY4, 5069-IY4K
Input range, resistive	1...500 Ω 2...1000 Ω 4...2000 Ω 8...4000 Ω
Input type, RTD	100, 200, 500, 1000 Ω platinum, alpha=385 100, 200, 500, 1000 Ω platinum, alpha=3916 120 Ω nickel, alpha=672 100, 120, 200, 500 Ω nickel, alpha=618 10 Ω copper 427
Input range, thermocouple	± 100 mV
Input type, thermocouple	B, C, D, E, J, K, L (TXK/XK), N, R, S, T
Input impedance	Voltage: >1 MΩ Current: 90 Ω typical, 70...110 Ω range RTD: >1 MΩ Thermocouple/millivolt: >1 MΩ
Common mode voltage (channel to channel)	±10V (Current mode and 3-wire RTD mode) ±2V (Voltage mode)
Module conversion method	Sigma-Delta, One 24-bit multiplexed ADC
Resolution, voltage ⁽³⁾ (16 bits at 10 Hz notch filter)	±10.5V: <320 μV/count (15 bits plus sign bipolar) 0...10.5V: <160 μV/count (16 bits unipolar) 0...5.25V: <80 μV/count (16 bits unipolar)
Resolution, current ⁽³⁾ (16 bits at 10 Hz notch filter)	0...21 mA: <0.32 μA/count (16 bits) 3.6...21 mA: <0.27 μA/count (16 bits)
Resolution, RTD ⁽³⁾ (16 bits at 10 Hz notch filter) 3 Wire mode	< 7.9 mΩ/cnt in 1...500 Ω mode < 15.8 mΩ/cnt in 2...1000 Ω mode < 31.7 mΩ/cnt in 4...2000 Ω mode < 63.4 mΩ/cnt in 8...4000 Ω mode
Resolution, thermocouple / millivolt ⁽³⁾ (16 bits at 10 Hz notch filter)	< 3.1 μV/cnt in ±100 mV mode
RTD excitation current	600 μA, 3 wire mode 100 μA, 2 wire mode
Wire impedance (3-wire RTD mode only)	25 Ω maximum for specified accuracy

Technical Specifications - 5069-IY4, 5069-IY4K

Attribute	5069-IY4, 5069-IY4K
RTD sensor types:	Supported temperature ranges:
100, 200, 500, 1000 Ohm PT 385	-200...+870 °C (-328...+1598 °F) 73...1143 °K (132...2058 °R)
100, 200, 500, 1000 Ohm PT 3916	-200...+630 °C (-328...+1166 °F) 73...903 °K (132...1626 °R)
10 Ohm CU 247	-200...+260 °C (-328...+500 °F) 73...533 °K (132...960 °R)
120 Ohm NI 672	-80...+320 °C (-112...+608 °F) 193...593 °K (348...1068 °R)
100, 120, 200, 500 Ohm NI 618	-60...+250 °C (-76...+482 °F) 213...523 °K (384...942 °R)
Thermocouple type:	Supported temperature ranges:
Thermocouple Type B	21...1820 °C (68...3308 °F) 293...2093 °K (528...3768 °R)
Thermocouple Type C	0...2320 °C (32...4208 °F) 273...2593 °K (492...4668 °R)
Thermocouple Type D	
Thermocouple Type E	-270...+1000 °C (-454...+1832 °F) 3...1273 °K (6...2292 °R)
Thermocouple Type J	-210...+1200 °C (-346...+2192 °F) 63...1473 °K (114...2652 °R)
Thermocouple Type K	-270...+1372 °C (-454...+2502 °F) 3...1645 °K (6...2961 °R)
Thermocouple Type N	-270...+1300 °C (-454...+2372 °F) 3...1573 °K (6...2832 °R)
Thermocouple Type R	-50...+1768 °C (-58...+3215 °F) 223...2041 °K (402...3674 °R)
Thermocouple Type S	
Thermocouple Type T	-270...+400 °C (-454...+752 °F) 3...673 °K (6...1212 °R)
Thermocouple Type TXK/XK (L)	-200...+800 °C (-328...+1472 °F) 73...1073 °K (132...1932 °R)
Thermocouple linearization	ITS-90
CJC inputs (for thermocouple mode use only)	Two CJC sensors: 2 thermistors embedded in a 5069-RTB14CJC RTB -or- 2 thermistors wired to a 5069-RTB18 RTB Thermistor type: Measurement Specialties, Inc. 10K3A1A
Local CJC sensor accuracy	±0.54 °F (±0.3 °C)
Remote CJC sensor accuracy (Based on specified thermistor)	±0.54 °F (±0.3 °C)
Calibrated accuracy at 77 °F (25 °C)	Voltage 0.100% full scale Current 0.100% full scale RTD 0.100% full scale Thermocouple/millivolt 0.100% full scale
Accuracy drift with temperature	Voltage 0.200% full scale Current 0.300% full scale RTD 0.200% full scale Thermocouple/millivolt 0.200% full scale
Input Total Unadjusted Error (TUE) ⁽⁴⁾ (Over full temperature range)	Voltage 0.300% Full Scale Current 0.400% Full Scale RTD 0.300% Full Scale Thermocouple/millivolt 0.300% Full Scale

Technical Specifications - 5069-IY4, 5069-IY4K

Attribute	5069-IY4, 5069-IY4K
Scan time	Per channel: 625 µs Per group (channel group 0...3): 2.5 ms
Notch filter at minimum RPI (0.2 ms, 1 channel enabled)	62.5 kHz
Minimum notch filter frequency at RPI of 2.5 ms	10 kHz
Step response time to 63% of value (Notch filter 10 kHz)	7.5 ms
Input notch filter (Hz) selections	5, 10 (50/60 default), 15, 20, 50, 60, 100, 200, 500, 1000, 2500, 5000, 10000, 15625, 25000, 31250, 62500
Input anti-aliasing filter cutoff frequency, typical	500 Hz
Input digital filter	First Order Lag, 0 ms (Default)...32,767 ms (32.767 s)
HART handheld compliance:	Add an external 250 Ω resistor into the current loop for HART transmitter compliance.
Overvoltage protection, max	Voltage, current, RTD, and thermocouple/mV modes: ± 30V DC
Overcurrent protection, max	Current mode: ± 30 mA
Data value during overload condition	Full scale, overrange flag, Data uncertain / data bad
Open circuit detection time, nom	Voltage: + full scale, < 2 s Current: 4...20 mA range, < 2 s RTD: < 2 s Thermocouple / millivolt: + full scale, < 10 s
Features, supported	The module supports these features. • Onboard data alarming • Scaling to engineering units • Real-time channel sampling
Data format	IEEE 32-bit floating point

- (1) The level of Mod power or SA power current that passes through the module. This level depends on the system configuration, such as, module slot location and the other module types that are used in the system. For more information, see the controller user manuals in the [Additional Resources](#).
- (2) Use this Conductor Category information to plan conductor routes. See the Industrial Automation Wiring and Grounding Guidelines, publication [1770-4.1](#).
- (3) Notch filter dependent.
- (4) Includes offset, gain, non-linearity, and repeatability error terms.

For **Wiring and Installation Specifications**, see [page 17](#).

For **Certifications**, see [page 18](#).

For **Environmental Specifications**, see [page 18](#).

5069-OF4IH

4-channel isolated current/voltage/HART output module

IMPORTANT: This module does not support the use of the voltage input and current input terminals on the same channel at the same time.

Current Devices Output Wiring - 5069-OF4IH

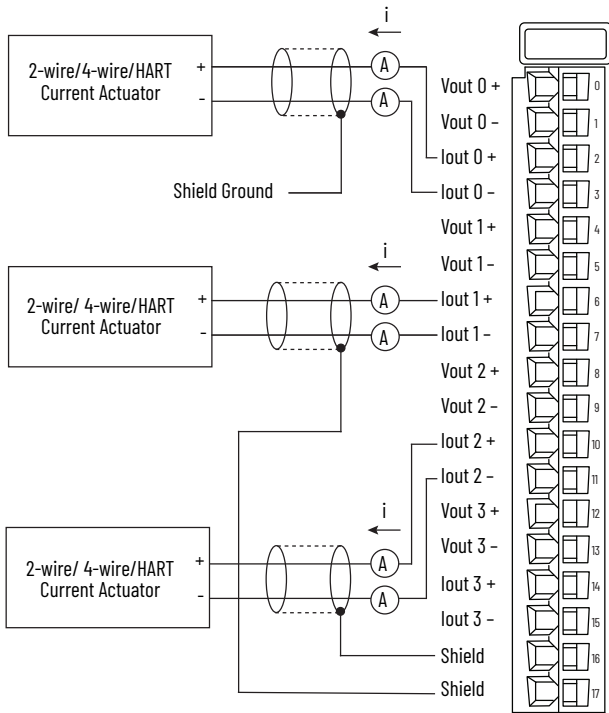

Voltage Devices Output Wiring - 5069-OF4IH

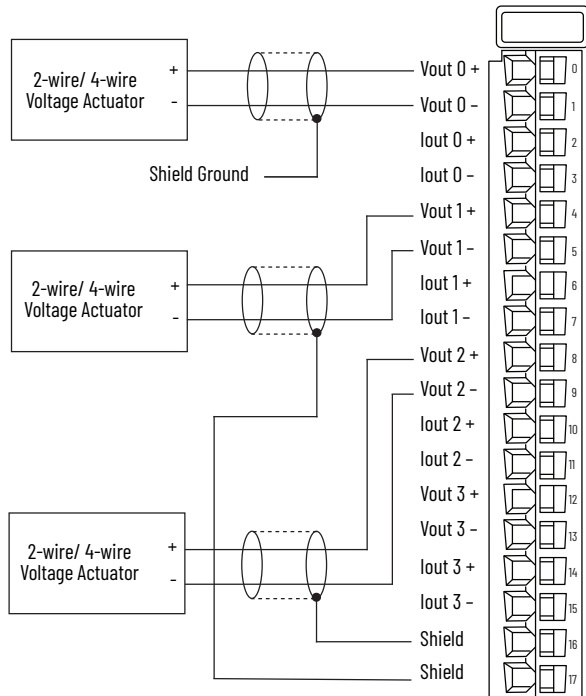

Functional Block Diagram - 5069-OF4IH
Current or HART Actuator

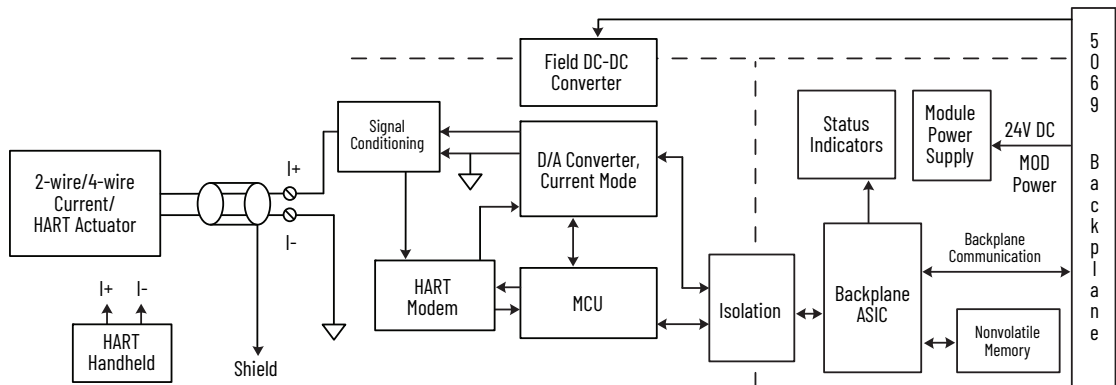

Functional Block Diagram - 5069-OF4IH
Voltage Actuator

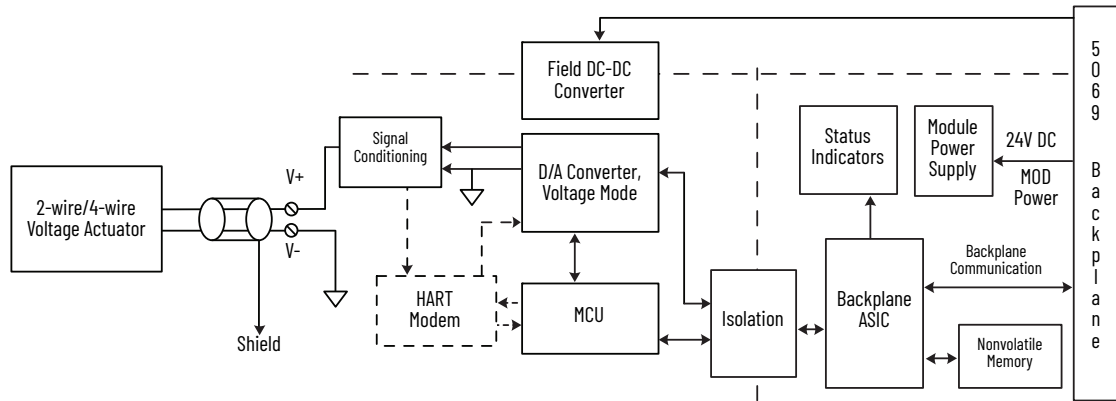

Technical Specifications - 5069-0F4IH

Attribute	Value
Outputs	4 individually isolated
Output range, voltage	±10V 0...10V 0...5V
Output range, current	0...20 mA 4...20 mA (HART)
Voltage and current ratings	
Analog output ratings	+/-10V DC, 0...20 mA (per channel)
MOD power	75 mA @ 18...32V DC
MOD power (passthrough) ⁽¹⁾	9.55 A @ 18...32V DC
SA power	200 mA @ 18...32V DC
SA power (passthrough) ⁽¹⁾	9.85 A @ 18...32V DC
Power dissipation, max	4.0 W
Thermal dissipation, max	11.3 BTU/hr
Isolation voltage	250V (continuous), Basic Insulation Type, <ul style="list-style-type: none"> SA to: Channel, FE, MP, or System MP to: Channel or FE System to: Channel, FE, or MP Channel to: Channel or FE
Calibration methods	Factory calibrated User-performed (optional)
Indicators	1 green/red module status indicator 4 yellow/red I/O status indicator
Wire category ⁽²⁾	2 - shielded output ports 1 wire per terminal for each signal port
Resolution	16 bits ±10V: 366µV/bit 0...10V: 183µV/bit 0...5V: 90µV/bit 0...20mA: 366 nA/bit 4...20mA: 366 nA/bit
Drive capability	Voltage mode: 1000 Ω min Current mode: 750 Ω max
Capacitive load, max (voltage mode only)	1 µF
Inductive load, max (current mode only)	1 mH

Technical Specifications - 5069-0F4IH

Attribute	Value
Open circuit detection	Current mode only
Short circuit detection	Voltage mode only
Data format	IEEE 754, 32-bit floating point
Module conversion method	R-Ladder DAC, monotonicity with no missing codes
Conversion time per channel at 25 °C (77 °F), typical	Voltage mode: 0.2 ms Current mode: 0.6 ms
HART scan time	1 s typical These items can increase the update time significantly. <ul style="list-style-type: none"> Additional device variables Configured commands Pass through messages Handheld communicators Secondary masters Communication errors Configuration changes
Scan time, all channels	1.5 ms
Step response time to 63% of value	2.5 ms
Overvoltage protection, max	Voltage mode: ± 32V DC Current mode: + 32V DC
Repeatability	0.05%
Calibrated accuracy at 25 °C (77 °F)	Voltage and Current mode: 0.05% full scale
Accuracy drift with temperature	Voltage and Current mode: 0.10% full scale

(1) The level of Mod power or SA power current that passes through the module. This level depends on the system configuration, such as, module slot location and the other module types that are used in the system. For more information, see the controller user manuals in the [Additional Resources](#).

(2) Use this Conductor Category information to plan conductor routes. See the Industrial Automation Wiring and Grounding Guidelines, publication [1770-4.1](#).

For **Wiring and Installation Specifications**, see [page 17](#).

For **Certifications**, see [page 18](#).

For **Environmental Specifications**, see [page 18](#).

5069-OF4, 5069-OF4K, and 5069-OF8

Analog Current/Voltage Output Modules

Current Mode Output Wiring - 5069-OF4 and 5069-OF4K

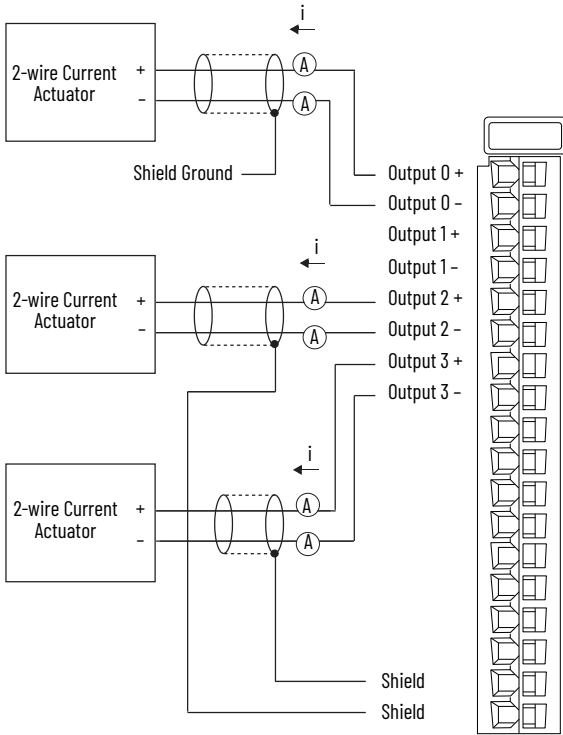

Current Mode Output Wiring - 5069-OF8

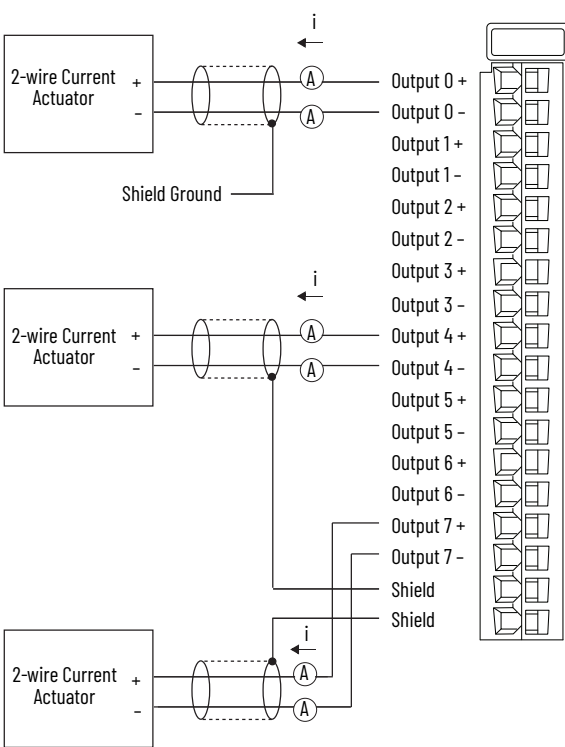

Voltage Mode Output Wiring - 5069-OF4 and 5069-OF4K

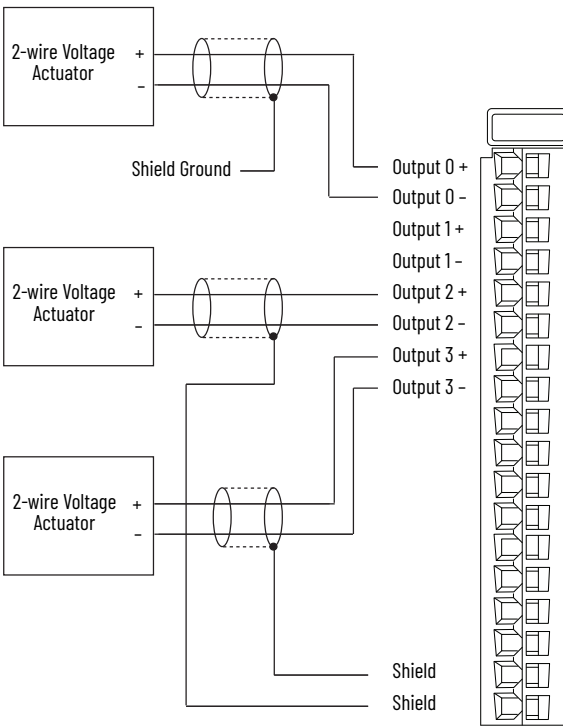

Voltage Mode Output Wiring - 5069-OF8

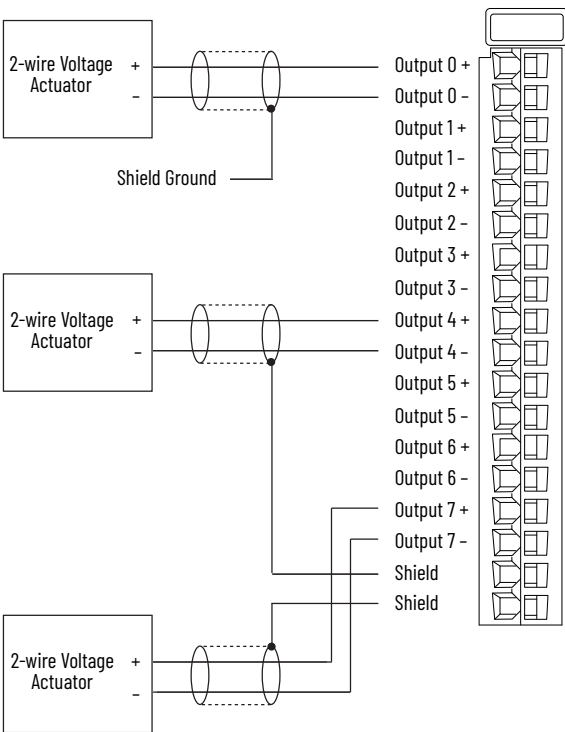

Functional Block Diagram - 5069-OF4, 5069-OF4K

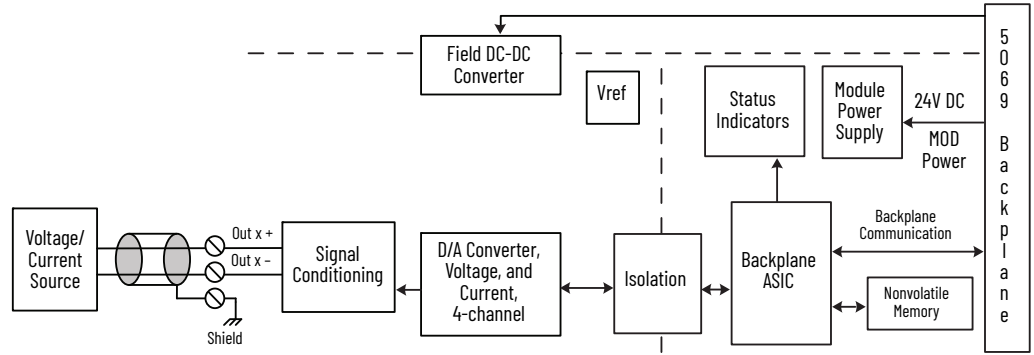

Functional Block Diagram - 5069-OF8

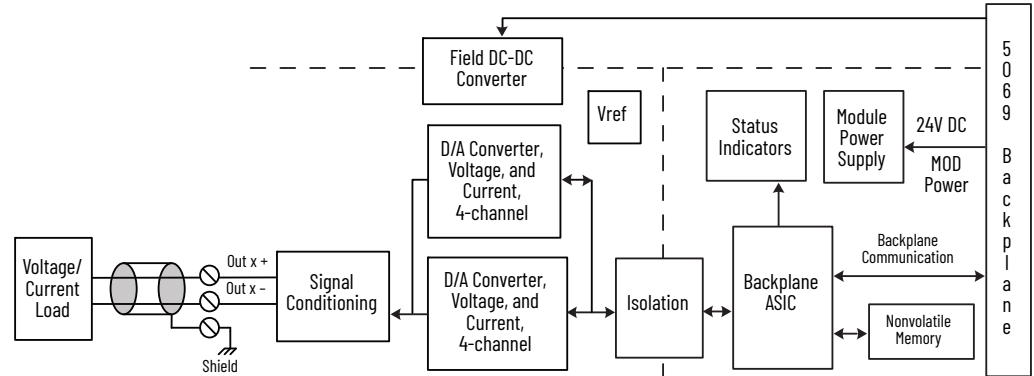

Technical Specifications - 5069-OF4, 5069-OF4K, 5069-OF8

Attribute	5069-OF4, 5069-OF4K	5069-OF8
Outputs	4 voltage or current	8 voltage or current
Output range, voltage	± 10V 0...10V 0...5V	
Output range, current	0...20 mA 4...20 mA	
Voltage and current ratings		
Analog output ratings	+/-10V DC, 0...20 mA per channel	
MOD power	75 mA @ 18...32V DC	
MOD power (passthrough) ⁽¹⁾	9.55 A @ 18...32V DC	
SA power	150 mA @ 18...32V DC	250 mA @ 18...32V DC
SA power (passthrough) ⁽¹⁾	9.95 A @ 18...32V DC	
Power dissipation, max	3.3 W	5.3 W
Thermal dissipation, max	11.3 BTU/hr	18.1 BTU/hr
Isolation voltage	250V (continuous), Basic Insulation Type 50V Functional Isolation between SA power and output ports No isolation between individual output ports	
Calibration methods	Factory Calibrated User-performed (optional)	
Indicators	1 green/red module status indicator	
	4 yellow/red I/O status indicators	8 yellow/red I/O status indicators
Wire category ⁽²⁾	2 - shielded output ports 1 wire per terminal for each signal port	
Resolution	16 bits across ± 10.5V - 320 µV/bit 16 bits across 10.5V - 160 µV/bit 16 bits across 5.25V - 80 µV/bit 16 bits across 21 mA - 320 nA/bit	
Drive capability	Voltage mode: 1000 Ω min Current mode: 500 Ω max	

Technical Specifications - 5069-OF4, 5069-OF4K, 5069-OF8

Attribute	5069-OF4, 5069-OF4K	5069-OF8
Capacitive load, max (voltage mode only)	1 µF	
Inductive load, max (current mode only)	1 mH	
Open circuit detection	Current mode only	
Short circuit detection	Voltage mode only: Output electronically limited to 16 mA or less	
Data format	IEEE 32-bit floating point	
Module conversion method	R-Ladder DAC, monotonicity with no missing codes	
Conversion time per channel	25 µs	
Scan time	Per group 0...3: 1.0 ms	Per group 0...3: 1.0 ms Per group 0...7: 2.0 ms
Step response time to 63% of value	Voltage mode: 18 µs max Current mode - 1 ms max	
Overvoltage protection, max	± 32V DC	
Repeatability	0.05%	
Calibrated accuracy at 25 °C (77 °F)	Voltage - 0.10% full scale Current - 0.10% full scale	
Accuracy drift with temperature	Voltage - 0.30% full scale Current - 0.50% full scale	

(1) The level of Mod power or SA power current that passes through the module. This level depends on the system configuration, such as, module slot location and the other module types that are used in the system. For more information, see the controller user manuals in the [Additional Resources](#).
 (2) Use this Conductor Category information to plan conductor routes. See the Industrial Automation Wiring and Grounding Guidelines, publication [1770-4.1](#).

For **Wiring and Installation Specifications**, see [page 17](#).
 For **Certifications**, see [page 18](#).
 For **Environmental Specifications**, see [page 18](#).

Safety I/O Modules

For information that applies to all of the safety I/O modules, see these tables.

- [Wiring and Installation Specifications - Safety I/O Modules](#)
- [Certifications - Safety I/O Modules](#)
- [Environmental Specifications - Safety I/O Modules](#)

The following safety modules are available.

I/O Type	Cat. No.	Description	Page
DC safety sinking input	5069-IB8S	18...32V DC 8-point, safety sinking input module	34
	5069-IB8SK	18...32V DC 8-point, conformal coated safety sinking input module	
DC safety output	5069-OBV8S	18...32V DC 8-point, safety output module that can be used as a Bipolar output module or sourcing output module	36
	5069-OBV8SK	18...32V DC 8-point, conformal coated safety output module that can be used as a Bipolar output module or sourcing output module	

Wiring and Installation Specifications - Safety I/O Modules

Attribute	5069-IB8S, 5069-IB8SK	5069-OBV8S, 5069-OBV8SK
Channel connections	The wiring diagrams show devices that are connected to specific channels or channel pairs. You are not restricted to using only those channels or channel pairs. You can connect devices to any channel, channel pair, or combination of channels, or channel pairs, as needed.	
SA power device list	Connections to an external power supply that provides SA power via the SA power RTB on one of these devices. <ul style="list-style-type: none"> • Compact GuardLogix 5380 controller • 5069-AENTR or 5069-AEN2TR EtherNet/IP Adapter • 5069-FPD field potential distributor 	
Isolate SA power	If you install modules in a system that uses both AC SA power and DC SA power, you must isolate SA power buses by type with a 5069-FPD field potential distributor. To create separate SA power buses, complete these steps. <ol style="list-style-type: none"> 1. Install the modules that use one type of SA power, for example DC, to the right of the adapter or controller. This is the first SA power bus. 2. To create a second SA power bus, install the 5069-FPD field module to the right of these modules. 3. Install the modules that use the other type of SA power, for example AC, to the right of the 5069-FPD module. 	
Slot width	1	1.5
Dimensions (HxWxD)	144.57 x 22 x 105.42 mm (5.69 x 0.87 x 4.15 in.)	144.57 x 36 x 105.42 mm (5.69 x 1.42 x 4.15 in.)
Weight, approx	175 g (0.39 lb)	240 g (0.53 lb.)
DIN rail	Compatible zinc-plated chromate-passivated steel DIN rail. You can use the EN50022 - 35 x 7.5 mm (1.38 x 0.30 in.) DIN rail.	
Module keying	Electronic keying via programming software	
RTB	5069-RTB18-SPRING RTB or 5069-RTB18-SCREW RTB, according to your system NOTE: RTBs do not ship with Compact 5000™ I/O modules, you must order them separately. Order only the RTB type that your system requires.	
RTB torque	Screw-type RTB only: 0.4 N•m (3.5 lb•in)	
RTB keying	None	
Wire size	0.5...1.5 mm ² (22...16 AWG) solid or stranded shielded copper wire rated at 105 °C (221 °F) or greater 5069-RTB18-SPRING RTB: 2.9 mm (0.11 in.) max diameter including insulation, single wire connection only. 5069-RTB18-SCREW RTB: 3.5 mm (0.14 in.) max diameter including insulation, single wire connection only. For the 5069-OW16 module only: Use minimum 18 AWG, 105 °C (221 °F) rated wire for load connections to relay output modules.	
Insulation-stripping length	5069-RTB18-SPRING RTB: 10 mm (0.39 in.) 5069-RTB18-SCREW RTB: 12 mm (0.47 in.)	

Environmental Specifications - Safety I/O Modules

Attribute	5069-IB8S, 5069-IB8SK, 5069-OBV8S, 5069-OBV8SK
Temperature, operating IEC 60068-2-1 (Test Ad, Operating Cold) IEC 60068-2-2 (Test Bd, Operating Dry Heat) IEC 60068-2-14 (Test Nb, Operating Thermal Shock)	0 °C ≤ Ta ≤ +60 °C (+32 °F ≤ Ta ≤ +140 °F)
Temperature, surrounding air, maximum	System mounted in horizontal orientation: 60 °C (140 °F) System mounted in any orientation other than horizontal (module derating): 50 °C (122 °F) NOTE: The additional supported mounting orientations are inverted horizontal, vertical, inverted vertical, upside down, and upside up.
Temperature, nonoperating IEC 60068-2-1 (Test Ab, Unpackaged Nonoperating Cold) IEC 60068-2-2 (Test Bb, Unpackaged Nonoperating Dry Heat) IEC 60068-2-14 (Test Na, Unpackaged Nonoperating Thermal Shock)	-40...+85 °C (-40...+185 °F)
Relative humidity IEC 60068-2-30 (Test Db, Unpackaged Damp Heat)	5...95% noncondensing
Vibration IEC 60068-2-6 (Test Fc, Operating)	5 g @ 10...500 Hz
Shock, operating IEC 60068-2-27 (Test Ea, Unpackaged Shock)	30 g
Shock, nonoperating IEC 60068-2-27 (Test Ea, Unpackaged Shock)	50 g
Emissions	IEC 61000-6-4
ESD immunity IEC 61000-4-2	6 kV contact discharges 8 kV air discharges
Radiated RF immunity IEC 61000-4-3	20V/m with 1 kHz sine wave 80% AM from 80...6000 MHz
EFT/B immunity IEC 61000-4-4	±4 kV @ 5 kHz on signal ports
Surge transient immunity IEC 61000-4-5	±1 kV line-line (DM) and ±2 kV line-earth (CM) on signal ports
Conducted RF immunity IEC 61000-4-6	20V rms with 1 kHz sine wave 80% AM from 150 kHz...80 MHz
Voltage variation IEC 61000-4-29	10 ms interruption on DC supply ports
North American temp code	T4
UKEX/ATEX temp code	T4
IECEX temp code	T4
Enclosure type	None (open-style)

Certifications - Safety I/O Modules

Certification	5069-IB8S, 5069-IB8SK, 5069-OBV8S, 5069-OBV8SK
c-UL-us	UL Listed Industrial Control Equipment, certified for US and Canada. See UL File E322657. UL Listed for Class I, Division 2 Group A,B,C,D Hazardous Locations, certified for U.S. and Canada. See UL File E334470.
UKCA and CE	UK Statutory Instrument 2016 No. 1091 and European Union 2014/30/EU EMC Directive, compliant with: EN 61326-1; Meas./Control/Lab., Industrial Requirements EN 61000-6-2; Industrial Immunity EN 61000-6-4; Industrial Emissions EN 61131-2; Programmable Controllers (Clause 8, Zone A & B) UK Statutory Instrument 2008 No. 1597 and European Union 2006/42/EC MD, compliant with: EN 60204-1; Electrical equipment of machines EN ISO 13849-1; Safety-related parts of control systems EN 62061; Functional safety of safety-related control systems Cat. 4/PLe according to EN ISO 13849-1, and SIL 3 according to EN 62601/IEC 61508/IEC 62511 UK Statutory Instrument 2012 No. 3032 and European Union 2011/65/EU RoHS, compliant with: EN IEC 63000; Technical documentation
RCM	Australian Radiocommunications Act, compliant with EN 61000-6-4; Industrial Emissions
Ex	UK Statutory Instrument 2016 No. 1107 and European Union 2014/34/EU ATEX Directive, compliant with: EN IEC 60079-0; General Requirements EN IEC 60079-7; Explosive Atmospheres, Protection "e" II 3 G Ex ec IIC T4 Gc DEMKO 18 ATEX 2019X and UL22UUEX2496
IECEX	IECEX System, compliant with: IEC 60079-0; General Requirements IEC 60079-7; Explosive Atmospheres, Protection "e" II 3 G Ex ec IIC T4 Gc IECEX UL 18.0014X
TÜV	TÜV Certified for Functional Safety; Capable of SIL 3, CAT. 4/PLe NOTE: When used with specified firmware revisions. See the Product Safety Certificate at rok.auto/certifications for a full list of safety-related certifications.
KC	Korean Registration of Broadcasting and Communications Equipment, compliant with: Article 58-2 of Radio Waves Act, Clause 3
Morocco	Arrêté ministériel n° 6404-15 du 1 ^{er} muharram 1437 Arrêté ministériel n° 6404-15 du 29 ramadan 1436
CCC	CNCA-C23-01:2019 强制性产品认证实施规则 防爆电气 CNCA-C23-01:2019 CCC Implementation Rule Explosion-Proof Electrical Products CCC: 202012230911301 and 2021122309113957

See the Product Certification link at rok.auto/certifications for Declarations of Conformity, Certificates, and other certification details.

5069-IB8S and 5069-IB8SK

Safety Sinking Input Modules

IMPORTANT: The modules use DC SA power. You must connect DC power to the device that supplies SA power to the module. See the [SA power device list](#) and [Isolate SA power](#).

Single Channel with Switches and Light Curtain Wiring - 5069-IB8S and 5069-IB8SK

- When the module is wired as shown, it is suitable for applications that are rated up to, and including, **Category 3** as defined in ISO 13849-1.
- The switches are suitable for applications that are rated up to, and including, SIL CL 3, PLe, Cat. 3.
- The light curtain is suitable for applications that are rated up to, and including, SIL CL 3, PLe, Cat. 4.

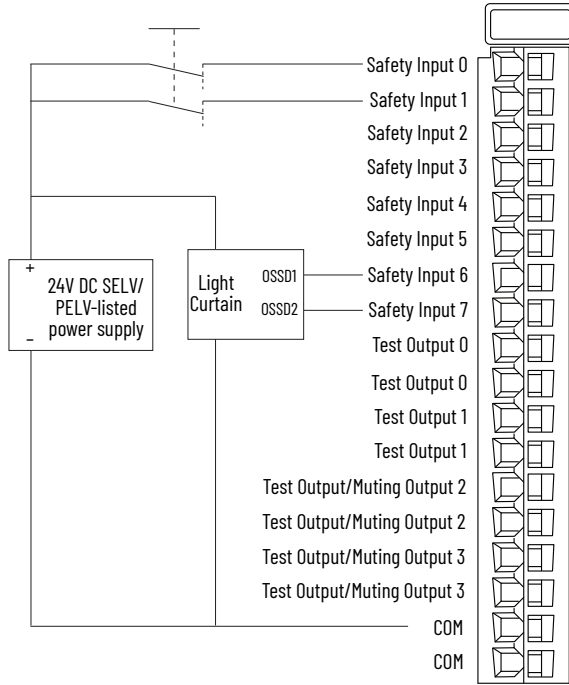

Single Channel with Switches and Muting Lamp Wiring - 5069-IB8S and 5069-IB8SK

- When the module is wired as shown, and the requirements listed are met in the project of the safety controller, it is suitable for applications that are rated up to, and including, **Category 4** as defined in ISO 13849-1. To achieve that suitability rating, you may have to perform diagnostic testing and monitoring of the safety function. One diagnostic test method is to configure the safety input channel for Safety Pulse Test to test the circuit for short circuits to 24V DC.
- Safety input pairs must be associated with different Test Output sources.
- When the power supply and muting lamp are configured for a test output, you must connect the return wire on the device to a COM point on the module.

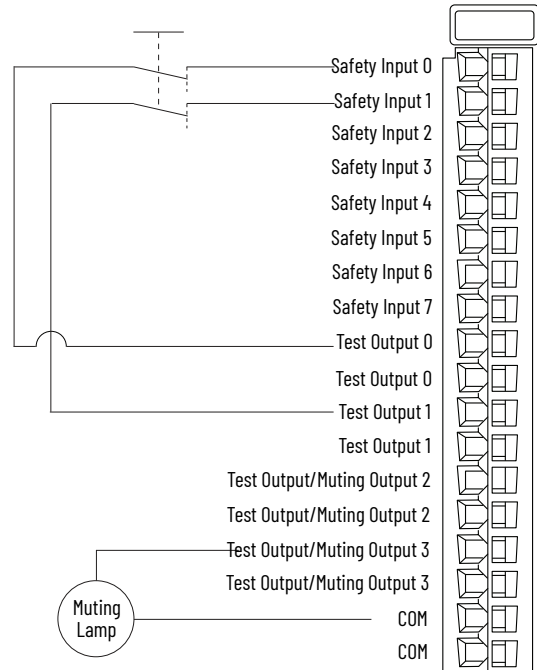

Single Channel with Sensor Wiring - 5069-IB8S and 5069-IB8SK

When the module is wired as shown, and the requirements listed are met in the project of the safety controller, it is suitable for applications that are rated up to, and including, Category 3 as defined in ISO 13849-1.

To achieve that suitability rating, you must meet the following requirements:

- Fault Exclusion is an External Wiring fault.
- Use a SIL CL 3, PLd, Cat. 3 qualified sensor.
- One of the following configuration combinations:
 Input Point Mode = Safety Pulse Test
 Test Output Mode = Pulse Test
 Input Point Mode = Safety
 Test Output Mode = Power Supply

IMPORTANT:

- We recommend that you connect even-numbered input points to even-numbered test output points and odd-numbered input points to odd-numbered test output points. This wiring practice can maximize diagnostic independence and separation.
- The SA power to adjacent SA power electrical isolation that the 5069-FPD field potential distributor provides has a rating of 240V AC (continuous) reinforced insulation type.

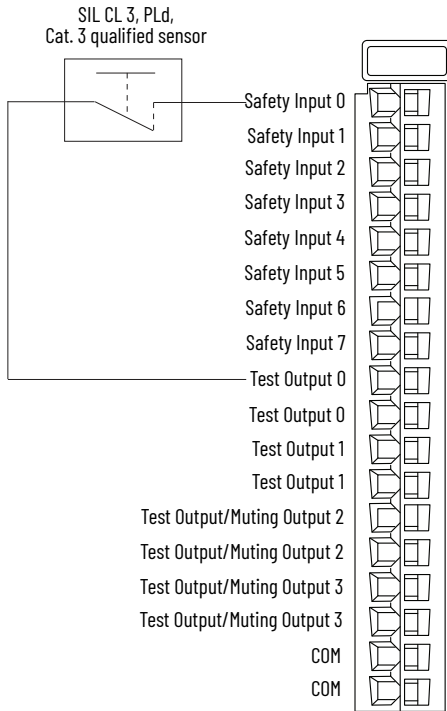

Technical Specifications - 5069-IB8S and 5069-IB8SK

Attribute	5069-IB8S, 5069-IB8SK	
Inputs	8 channels, safety sinking	
Test Outputs	2 test output channels 2 test output/muting output channels	
Voltage category	12/24V DC source	
Voltage and current ratings	System mounted in horizontal orientation:	System mounted in any orientation other than horizontal (module derating):
Input Rating	2.5 mA per channel	2.5 mA per channel
Test Output Rating	300 mA per channel	200 mA per channel
MOD power	75 mA @ 18...32V DC	75 mA @ 18...32V DC
MOD power (passthrough) ⁽¹⁾	5 A @ 18...32V DC	5 A @ 18...32V DC
SA power	1.3 A @ 18...32V DC	100 mA @ 18...32V DC
SA power (passthrough) ⁽¹⁾	9.95 A @ 18...32V DC	5 A @ 18...32V DC

Do not exceed 5 A MOD or SA power (passthrough) current draw in any orientation other than Horizontal.

NOTE: The additional supported mounting orientations are inverted horizontal, vertical, inverted vertical, upside down, and upside up.

Technical Specifications - 5069-IB8S and 5069-IB8SK

Attribute	5069-IB8S, 5069-IB8SK
Power dissipation, max	3.5 W
Thermal dissipation, max	4 W
Isolation voltage	250V (continuous), Basic Insulation Type
Indicators	1 green/red module status indicator 1 green/red SA power status indicator 12 yellow/red I/O status indicators
Wire category ⁽²⁾	2 - signal ports 1 wire per terminal for each signal port

Safety Inputs

On-state voltage, min	10V DC
On-state voltage, nom	24V DC
On-state voltage, max	32V DC
On-state current, min	1.8 mA
On-state current, nom	2 mA
On-state current, max	2.2 mA
Off-state voltage, max	5V DC
Off-state current, max	1.5 mA
Input delay time Off to On and On to Off	0 ms...50 ms, default = 0 ms
Safety integrity level (SIL)	SIL CL 3, PLd, Cat. 4
Safety reaction time (SRT)	6 ms

Test Outputs

Output current per channel, max	0.3 A
Output current per group, max	1.2 A
Output current per module, max	1.2 A
Test output pulse width	< 700 µs
Test output pulse period	< 100 ms
Test output field capacitance, max	0.5 µF
Test output leakage current	1.5 mA
SA power overvoltage protection, max	36.5V DC
Power consumption	3.8 W

Features, supported	The modules support these features. <ul style="list-style-type: none"> • Test output short circuit protection • Test output overvoltage protection (Thermal shutoff) • SA power reverse voltage protection • CIP Sync™
---------------------	--

Features, not supported	The modules do not support these features. <ul style="list-style-type: none"> • Time stamp of inputs • Overrides • Pulse latching • Events • Pattern matching • Extended counters • Scheduled outputs
-------------------------	--

(1) The level of Mod power or SA power current that passes through the module. This level depends on the system configuration, such as, module slot location and the other module types that are used in the system. For more information, see the controller user manuals in the [Additional Resources](#).

(2) Use this Conductor Category information to plan conductor routes. See the Industrial Automation Wiring and Grounding Guidelines, publication [1770-4.1](#).

For **Wiring and Installation Specifications**, see [page 32](#).

For **Certifications**, see [page 33](#).

For **Environmental Specifications**, see [page 33](#).

5069-OBV8S, 5069-OBV8SK

Safety Output Modules

You can use the safety output modules in Bipolar mode or Sourcing mode.

IMPORTANT:

- The modules do not draw current from the SA power bus. Still, the modules are DC-type modules and you must install them on a DC SA power bus. See the [SA power device list](#).
- LA Power - The Local Actuator (LA+ and LA-) power connections are used to supply field-side power to the module.
- If you have a direct connection between the safety output module and an input module and those modules are powered by separate power supplies, we recommend that you connect SA- and LA- together. This practice helps to prevent diagnostics disruption due to grounding float.
- Bipolar mode - The terminals for each channel function as a Bipolar connection pair when you use a 5069-OBV8S or 5069-OBV8SK module in Bipolar switching mode. For example, the Safety Output 0 P (Sourcing) terminal and the Safety Output 0 N (Sinking) terminal are a Bipolar connection pair. That is, they are a P-N pair. When the module is in Bipolar switching mode, you must connect the device to both terminals.
- For Category 4 applications, if your application remains in safe state, that is, the output is off, for a prolonged duration, we recommend that you take one of the following actions:
 - Apply output monitoring at the actuator. The monitoring can be direct or indirect.
 - Limit the safe state to no more than 24 hours.
 - Conduct functional test if safe state dwell time increases.

Bipolar Mode: Single Channel Output Wiring - 5069-OBV8S, 5069-OBV8SK

When the module is wired as shown, and the requirements listed are met in the project of the safety controller, it is suitable for applications that are rated up to, and including, **Category 4** as defined in ISO 13849-1. To achieve that suitability rating, you may have to perform diagnostic testing and monitoring of the safety function. One diagnostic test method is to configure the safety output channel for Safety Pulse Test to test the circuit for short circuits to 24V DC. Configure the application so that a No Load fault can only be detected if the wires from both the P- terminal and the N- terminal are disconnected. For Category 4 applications, if your application remains in safe state, that is, the output is off, for a prolonged duration, we recommend that you take one of the following actions:

- Apply output monitoring at the actuator. The monitoring can be direct or indirect.
- Limit the safe state to no more than 24 hours.
- Conduct functional test if safe state dwell time increases.

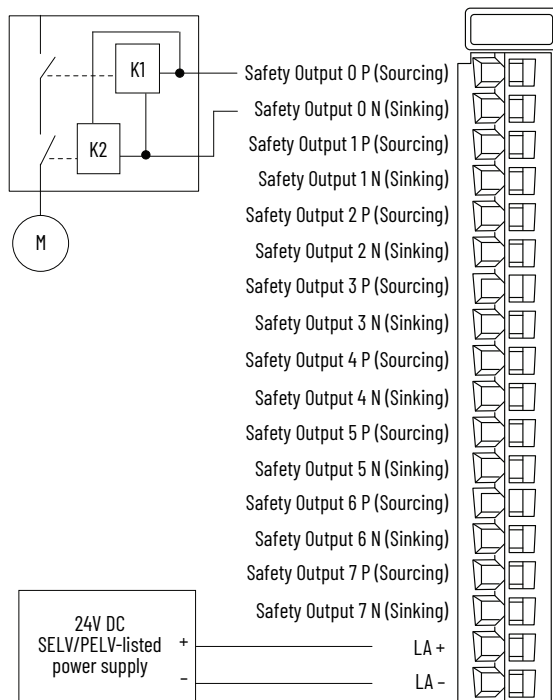

Bipolar Mode: Single Channel with Actuator Subsystem Wiring - 5069-OBV8S, 5069-OBV8SK

When the module is wired as shown, and the requirements listed are met in the project of the safety controller, it is suitable for applications that are rated up to, and including, **Category 4** as defined in ISO 13849-1. To achieve that suitability rating, you may have to perform diagnostic testing and monitoring of the safety function. One diagnostic test method is to configure the safety output channel for Safety Pulse Test to test the circuit for short circuits to 24V DC.

- We strongly recommend that you connect separate shielded cables to the P terminal and the N terminal to reduce the possibility of a wire short between the terminals. If a wire-short fault is detected across the P-N pair, the module outputs are turned off, but the actuator that is connected to it remains on.
- Configure the application so that No Load and Overload conditions are only detectable at the P terminal.

Actuator LA Power In this wiring configuration, you must connect the LA+ terminal to an SELV/PELV-listed power supply. The LA+ and LA- on the actuator must be connected to the same power supply as the LA+ and LA- on the module.

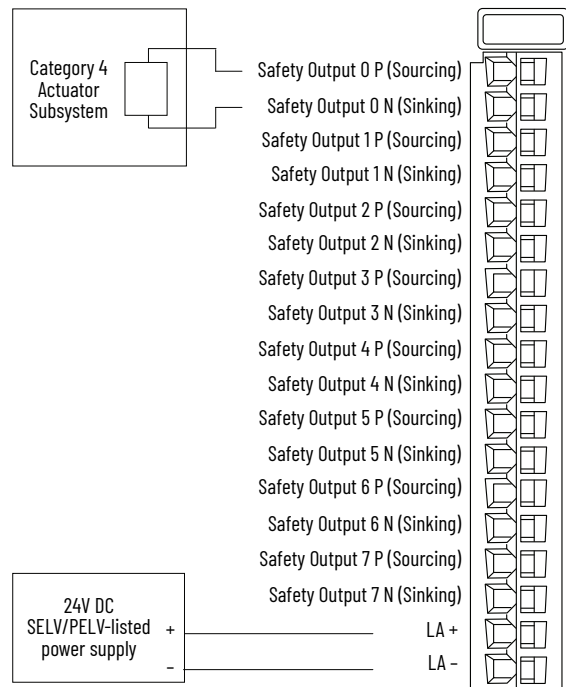

Bipolar Mode: Single Channel with Actuator Wiring - 5069-0BV8S, 5069-0BV8SK

When the module is wired as shown, and the requirements listed are met in the project of the safety controller, it is suitable for applications that are rated up to, and including, **Category 4** as defined in ISO 13849-1.

To achieve that suitability rating, you may have to perform diagnostic testing and monitoring of the safety function. One diagnostic test method is to configure the safety output channel for Safety Pulse Test to test the circuit for short circuits to 24V DC.

IMPORTANT: The SA power to adjacent SA power electrical isolation, that the 5069-FPD field potential distributor provides, has a rating of 240V AC (continuous) reinforced insulation type.

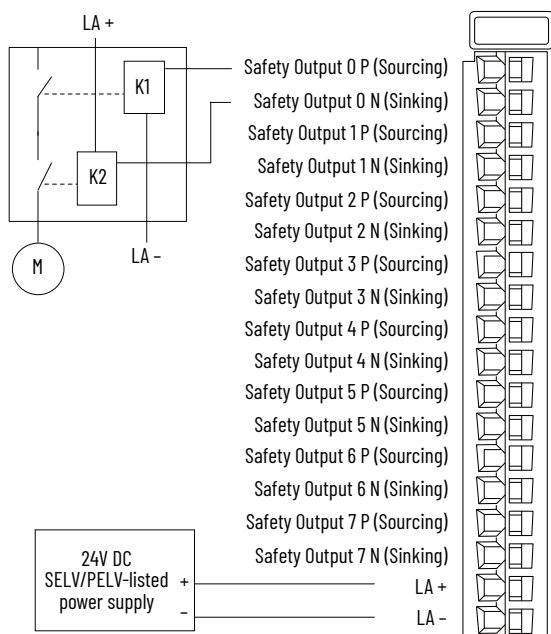

Sourcing Mode: Dual Channel with Actuator Wiring - 5069-0BV8S, 5069-0BV8SK

When the module is wired as shown, it is suitable for applications that are rated up to, and including, **Category 4** as defined in ISO 13849-1.

To achieve that suitability rating, you may have to perform diagnostic testing and monitoring of the safety function. One diagnostic test method is to configure the safety output channel for Safety Pulse Test to test the circuit for short circuits to 24V DC.

IMPORTANT: When you use dual-channel sourcing wiring, you must connect the devices to dual-channel connection pairs. These channels are dual-channel connection pairs: 0 and 1 (shown), 2 and 3, 4 and 5, 6 and 7.

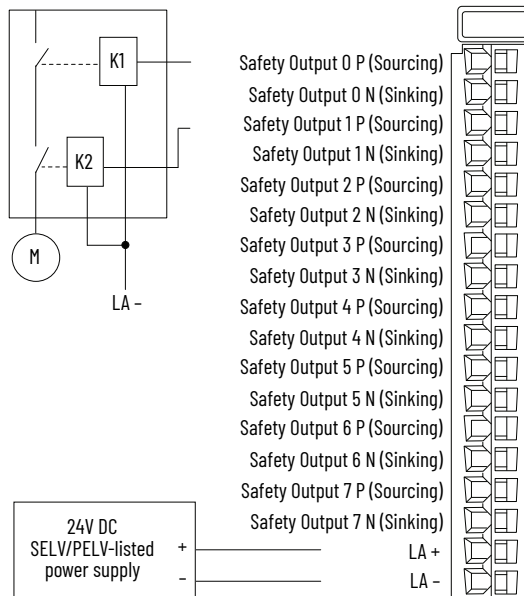

Sourcing Mode: Single Channel with Actuator Wiring - 5069-0BV8S, 5069-0BV8SK

When the module is wired as shown, it is suitable for applications that are rated up to, and including, **Category 2** as defined in ISO 13849-1.

To achieve that suitability rating, you may have to perform diagnostic testing and monitoring of the safety function. One diagnostic test method is to configure the safety output channel for Safety Pulse Test to test the circuit for short circuits to 24V DC.

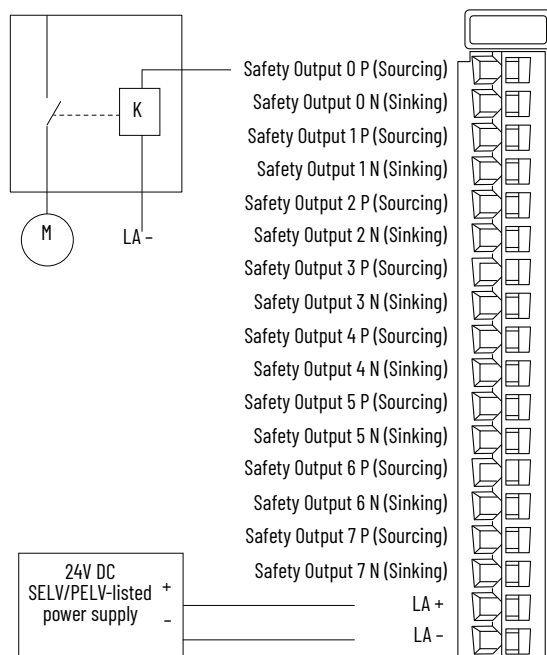

Sourcing Mode: Single Channel with Actuator Subsystem Wiring - 5069-0BV8S, 5069-0BV8SK

When the module is wired as shown, and the requirements listed are met in the project of the safety controller, it is suitable for applications that are rated up to, and including, **Category 4** as defined in ISO 13849-1.

To achieve that suitability rating, you may have to perform diagnostic testing and monitoring of the safety function. One diagnostic test method is to configure the safety output channel for Safety Pulse Test to test the circuit for short circuits to 24V DC.

- All power source cables must be installed separately, for example, with a separate cable duct or shielded cable. Power source cables are connections to the MOD+, SA+, or LA+ terminals.
- Otherwise, a Short Circuit condition between SA+ and P can be detected and the output is turned off but the actuator that is connected to it remains on.
- You must connect two ground terminals. Otherwise, the maximum residual current at signal 0 cannot be maintained if only one ground line is connected and it is interrupted.
- A qualified actuator must be installed, for example, in accordance with IEC 60947.

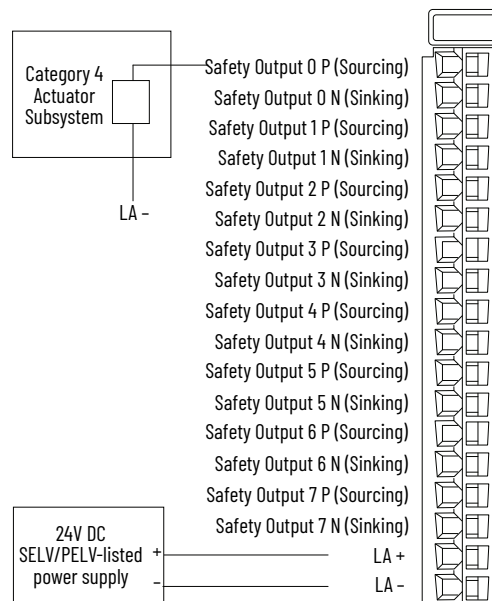

Technical Specifications - 5069-OBV8S, 5069-OBV8SK

Attribute	5069-OBV8S, 5069-OBV8SK	
Outputs	8	
Voltage category	24V DC	
Voltage and current ratings	System mounted in horizontal orientation:	System mounted in any orientation other than horizontal (module derating):
Output Rating	1 A per channel	0.7 A per channel
MOD power	75 mA @ 18...32V DC	75 mA @ 18...32V DC
MOD power (passthrough) ⁽¹⁾	5 A @ 18...32V DC	5 A @ 18...32V DC
LA power	1 A per channel @ 18...32V DC 8 A per module @ 18...32V DC	0.7 A per channel @ 18...32V DC 5.6 A per module @ 18...32V DC
SA power (passthrough) ⁽¹⁾	9.95 A @ 18...32V DC	5 A @ 18...32V DC
NOTE: The modules do not draw SA power current.		
Horizontal orientation - Do not exceed 5 A Mod or power (passthrough) current draw. Do not exceed 10 A SA power (passthrough) current draw. Any orientation other than Horizontal - Do not exceed 5 A MOD or SA power (passthrough) current draw. NOTE: The additional supported mounting orientations are inverted horizontal, vertical, inverted vertical, upside down, and upside up.		
Power dissipation, max	6.5 W	
Thermal dissipation, max	6.5 W	
Isolation voltage	250V (continuous), Basic Insulation Type No isolation between LA power and output ports No isolation between individual output ports	
Indicators	1 green/red module status indicator 1 green/red SA power status indicator 16 yellow/red I/O status indicators	
Wire category ⁽²⁾	2 - signal ports 1 wire per terminal for each signal port	
LA power attributes		
On-state voltage, min	17.5V DC	
On-state voltage, nom	24V DC	
On-state voltage, max	32V DC	
On-state voltage drop, max	0.5V DC	
On-state current per channel, min	10 mA	
Off-state voltage, max	0.5V DC	

Technical Specifications - 5069-OBV8S, 5069-OBV8SK

Attribute	5069-OBV8S, 5069-OBV8SK
Off-state leakage current per point, max	1.5 mA NOTE: To limit the effects of leakage current through solid-state outputs, you can connect a loading resistor in parallel with your load. For 24V DC operation, use a 5.6 KΩ, 0.5 W resistor for transistor operation.
Output current rating per channel	1 A
Surge current per point, max	1.5 A
Output delay time (backplane to screw) Off to On and On to Off	4 ms, max
Safety Integrity Level	SIL CL 3, PLe, Cat. 4
Safety reaction time (SRT)	4.5 ms
Pulse width, min	400 μs
Features, supported	The modules support these features. <ul style="list-style-type: none"> • Field power loss detection, per point • No load detection diagnostics, per point • Output short circuit/overload detection, per point • Output short circuit/overload protection, per point • Output overtemperature detection, per point • Output overtemperature protection, per point • Reverse voltage protection • Overvoltage protection, max • CIP Sync™
Features, not supported	The modules support these features. <ul style="list-style-type: none"> • Output control in fault mode per point
Output states	In program mode per point: Off In fault mode per point: Off
Duration of fault mode per point	Forever - Safety outputs turn off when the fault is detected and remain off until the cause of the fault is removed and the safety outputs are commanded into the safe state.
<p>(1) The level of Mod power or SA power current that passes through the module. This level depends on the system configuration, such as, module slot location and the other module types that are used in the system. For more information, see the controller user manuals in the Additional Resources.</p> <p>(2) Use this Conductor Category information to plan conductor routes. See the Industrial Automation Wiring and Grounding Guidelines, publication I770-4.1.</p>	

For **Wiring and Installation Specifications**, see [page 32](#).
For **Certifications**, see [page 33](#).
For **Environmental Specifications**, see [page 33](#).

Specialty Modules

For information that applies to all of the specialty modules, see these tables.

- [Wiring and Installation Specifications - Specialty Modules](#)
- [Certifications - Specialty Modules](#)
- [Environmental Specifications - Specialty Modules](#)

The following specialty modules are available.

Cat. No.	Description	Page
5069-AENTR and 5069-AENTRK	EtherNet/IP adapters	42
5069-AEN2TR	EtherNet/IP adapter	43
5069-ARM	Address reserve module	44
5069-FPD	Field potential distributor	44
5069-HSC2XOB4	High speed counter module	45
5069-SERIAL	Serial module	48

Wiring and Installation Specifications - Specialty Modules

Attribute	5069-ARM, 5069-HSC2XOB4	5069-FPD	5069-SERIAL	5069-AEN2TR	5069-AENTR, 5069-AENTRK
Slot width	1			4.5	3
Dimensions (HxWxD)	144.01 x 22 x 105.35 mm (5.67 x 0.87 x 4.15 in.)		144.01 x 25 x 105.35 mm (5.67 x 0.98 x 4.15 in.)	124.5 x 98.1 x 136.81 mm (4.9 x 3.86 x 5.39 in.)	141.36 x 63 x 105.3 mm (5.57 x 2.48 x 4.15 in.)
Weight, approx	175 g (0.39 lb)			680 g (1.50 lb)	485 g (1.07 lb)
DIN rail	Compatible zinc-plated chromate-passivated steel DIN rail. You can use the EN50022 - 35 x 7.5 mm (1.38 x 0.30 in.) DIN rail.				
Module keying	Electronic keying via programming software	None		Electronic keying via programming software	
RTB	5069-RTB18-SPRING or 5069-RTB18-SCREW	5069-RTB6-SCREW or 5069-RTB6-SPRING	-	5069-RTB64-SPRING or 5069-RTB64-SCREW	5069-RTB5-SPRING RTB or 5069-RTB5-SCREW RTB
	NOTE: RTBs do not ship with Compact 5000™ I/O modules, you must order them separately. Order only the RTB type that your system requires.				
RTB torque, screw-type RTB	0.4 N•m (3.5 lb•in)			0.5...0.6 N•m (4.4...5.3 lb•in)	
RTB keying	None				
Wire size	0.5...1.5 mm ² (22...16 AWG) solid or stranded shielded copper wire rated at 105 °C (221 °F) or greater Spring-type RTB: 2.9 mm (0.11 in.) max diameter including insulation, single wire connection only. Screw-type RTB: 3.5 mm (0.14 in.) max diameter including insulation, single wire connection only.			0.25...2.5 mm ² (22...14 AWG) solid or stranded copper wire rated at 105 °C (221 °F), or greater, 1.2 mm (3/64 in) insulation max diameter including insulation, single wire connection only. Grounding: 2.5 mm ² (14 AWG) solid or stranded copper wire rated at 105 °C (221 °F), or greater, 3.5 mm (0.14 in) max diameter including insulation, single wire connection only.	
				Ethernet cabling and installation according to IEC 61918 and IEC 61784-5-2	
Insulation-stripping length	5069-RTB18-SPRING RTB: 10 mm (0.39 in.) 5069-RTB18-SCREW RTB: 12 mm (0.47 in.)			5069-RTB5-SPRING RTB: 10 mm (0.39 in.) 5069-RTB5-SCREW RTB: 10 mm (0.39 in.)	

Environmental Specifications - Specialty Modules

Attribute	5069-ARM	5069-AENTR, 5069-AENTRK ⁽¹⁾	5069-FPD	5069-HSC2X0B4	5069-SERIAL
Temperature, operating IEC 60068-2-1 (Test Ad, Operating Cold) IEC 60068-2-2 (Test Bd, Operating Dry Heat) IEC 60068-2-14 (Test Nb, Operating Thermal Shock)	0...60 °C (32...140 °F)				
Temperature, surrounding air, max	60 °C (140 °F)				
Temperature, nonoperating IEC 60068-2-1 (Test Ab, Unpackaged Nonoperating Cold) IEC 60068-2-2 (Test Bb, Unpackaged Nonoperating Dry Heat) IEC 60068-2-14 (Test Na, Unpackaged Nonoperating Thermal Shock)	-40...+85 °C (-40...+185 °F)				
Relative humidity IEC 60068-2-30 (Test Db, Unpackaged Damp Heat)	5...95% noncondensing				
Vibration IEC 60068-2-6 (Test Fc, Operating)	5 g @ 10...500 Hz				
Shock, operating IEC 60068-2-27 (Test Ea, Unpackaged Shock)	30 g				
Shock, nonoperating IEC 60068-2-27 (Test Ea, Unpackaged Shock)	50 g				
Emissions	IEC 61000-6-4				
ESD immunity IEC 61000-4-2	6 kV contact discharges 8 kV air discharges				
Radiated RF immunity IEC 61000-4-3	10V/m with 1 kHz sine wave 80% AM from 80...6000 MHz				
EFT/B immunity IEC 61000-4-4	—	±3 kV @ 5 kHz on power ports ±3 kV @ 5 kHz on Ethernet ports	±4 kV @ 5 kHz on power ports	±4 kV @ 5 kHz on power ports ±2 kV @ 5 kHz on shielded output ports ±2 kV @ 5 kHz on shielded counter ports	±4 kV @ 5 kHz on power ports ±3 kV @ 5 kHz on communication ports
Surge transient immunity IEC 61000-4-5	—	±1 kV line-line (DM) and ±2 kV line-earth (CM) on power ports ±2 kV line-earth (CM) on Ethernet ports	±1 kV line-line (DM) and ±2 kV line-earth (CM) on power ports	±1 kV line-line (DM) and ±2 kV line-earth (CM) on power ports ±2 kV line-earth (CM) on shielded output ports ±2 kV line-earth (CM) on shielded counter ports	±1 kV line-line (DM) and ±2 kV line-earth (CM) on power ports ±2 kV line-earth (CM) on communication ports
Conducted RF immunity IEC 61000-4-6	—	10V rms with 1 kHz sine wave 80% AM from 150 kHz...80 MHz			
Voltage variation IEC 61000-4-29		On power and Ethernet ports	—		
ESD immunity IEC 61000-4-2	10 ms interruption on DC supply ports	—		10 ms interruption on MOD power port	—
North American temp code	T4				
UKEX/ATEX temp code	T4				
IECEX temp code	T4				
Enclosure type	None (open-style)				

(1) (1) For 5069-AEN2TR module environmental specifications, see [page 43](#).

Certifications - Specialty Modules

Certification	5069-ARM	5069-FPD	5069-HSC2X0B4	5069-AENTR, 5069-AENTRK ⁽¹⁾	5069-SERIAL
c-UL-us	UL Listed Industrial Control Equipment, certified for US and Canada. See UL File E65584. UL Listed for Class I, Division 2 Group A,B,C,D Hazardous Locations, certified for U.S. and Canada. See UL File E194810.			UL Listed Industrial Control Equipment, certified for US and Canada. See UL File E322657. UL Listed for Class I, Division 2 Group A,B,C,D Hazardous Locations, certified for U.S. and Canada. See UL File E334470.	
UKCA and CE	UK Statutory Instrument 2016 No. 1091 and European Union 2014/30/EU EMC Directive, compliant with: EN 61326-1; Meas./Control/Lab., Industrial Requirements EN 61000-6-2; Industrial Immunity EN 61000-6-4; Industrial Emissions EN 61131-2; Programmable Controllers (Clause 8, Zone A & B)				
	UK Statutory Instrument 2012 No. 3032 and European Union 2011/65/EU RoHS, compliant with: EN IEC 63000; Technical documentation				
	–			UK Statutory Instrument 2016 No. 1101 and European Union 2014/35/EU LVD, compliant with: EN 61010-2-201; Control Equipment Safety Requirements	
RCM	Australian Radiocommunications Act, compliant with EN 61000-6-4; Industrial Emissions				
Ex	UK Statutory Instrument 2016 No. 1107 and European Union 2014/34/EU ATEX Directive, compliant with: EN IEC 60079-0; General Requirements EN IEC 60079-7; Explosive Atmospheres, Protection "e" II 3 G Ex ec IIC T4 Gc				
	DEMKO 15 ATEX 1455X and UL22UKEK2307X			DEMKO 16 ATEX 1758X and UL22UKEK2494X	DEMKO 15 ATEX 1484X and UL22UKEK2379
	When used at or below 125V AC			–	
IECEX	IECEX System, compliant with: EN IEC 60079-0; General Requirements EN IEC 60079-7; Explosive Atmospheres, Protection "e" II 3 G Ex ec IIC T4 Gc				
	IECEX UL 15.0007X			IECEX UL 16.0124X	IECEX UL 15.0055X
	When used at or below 125V AC			–	
KC	Korean Registration of Broadcasting and Communications Equipment, compliant with: Article 58-2 of Radio Waves Act, Clause 3				
Morocco	Arrêté ministériel n° 6404-15 du 1 er muharram 1437 Arrêté ministériel n° 6404-15 du 29 ramadan 1436				
CCC	CNCA-C23-01:2019 强制性产品认证实施规则 防爆电气 CNCA-C23-01:2019 CCC Implementation Rule Explosion-Proof Electrical Products				
	CCC: 202012230911301 and 2021122309113957				CCC: 2020312309000308
EtherNet/IP	–			ODVA conformance tested to EtherNet/IP specifications	–

See the Product Certification link at rok.auto/certifications for Declarations of Conformity, Certificates, and other certification details.

(1) For 5069-AEN2TR module certifications, see [page 43](#).

5069-AENTR, 5069-AENTRK

EtherNet/IP Adapters

MOD Power Wiring - 5069-AENTR, 5069-AENTRK

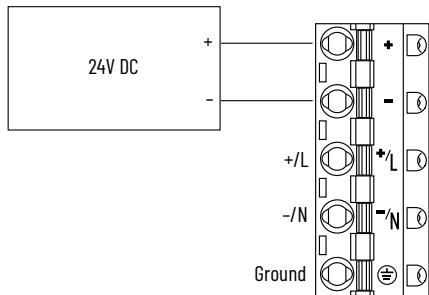

SA Power Wiring - 5069-AENTR, 5069-AENTRK

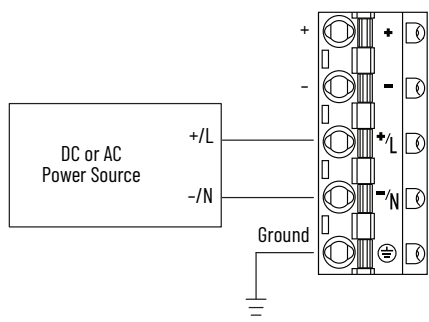

Technical Specifications - 5069-AENTR and 5069-AENTRK

Attribute	5069-AENTR, 5069-AENTRK
Voltage and current ratings	
MOD power	220 mA @ 18...32V DC
MOD power inrush	1750 mA for 70 ms
MOD power (passthrough) ⁽¹⁾	9.78 A @ 18...32V DC
SA power	5 mA @ 0...32V DC 2 mA @ 0...240V AC, 47...63 Hz Ex, 125V AC Max
SA power (passthrough) ⁽¹⁾	9.95 A @ 0...32V DC 9.975 A @ 0...240V AC, 47...63 Hz Ex, 125V AC Max
Do not exceed 10 A current draw at the MOD or SA power RTB.	
Recommended external overcurrent protection	MOD power: 10...12A @ 22.5...43.2 A2t, Fast Acting SA power: 20 A @ 250V AC
Power dissipation, max	8.5 W
Thermal dissipation, max	29 BTU/hr
Isolation voltage	300V (continuous), Basic Insulation Type, SA, and MOD power to Backplane 300V (continuous), Basic Insulation Type, SA to MOD power 300V (continuous), Basic Insulation Type, Ethernet to Backplane Type tested at 1500V AC for 60 s 300V (continuous), Double Insulation Type, Ethernet to MOD power 300V (continuous), Double Insulation Type, Ethernet to SA power Type tested at 4242V DC for 60 s No isolation between Ethernet ports
Wiring category ⁽²⁾	2 - on signal ports 1 - on power ports 2 - on Ethernet ports

(1) The level of Mod power or SA power current that passes through the module. This level depends on the system configuration, such as, module slot location and the other module types that are used in the system. For more information, see the controller user manuals in the [Additional Resources](#) table.

(2) Use this Conductor Category information to plan conductor routes. See the Industrial Automation Wiring and Grounding Guidelines, publication [1770-4.1](#).

For **Wiring and Installation Specifications**, see [page 39](#).

For **Certifications**, see [page 40](#).

For **Environmental Specifications**, see [page 41](#).

5069-AEN2TR

EtherNet/IP Adapter

MOD Power Wiring - 5069-AEN2TR

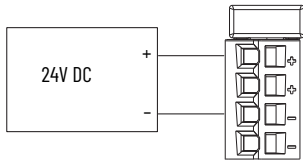

SA Power Wiring - 5069-AEN2TR

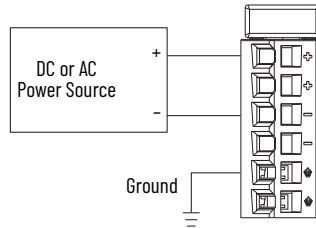

Technical Specifications - 5069-AEN2TR

Attribute	5069-AEN2TR
Voltage and current ratings	
MOD power	450 mA @ 18...32V DC
MOD power inrush	850 mA for 125 ms
MOD power (passthrough) ⁽¹⁾	9.55 A @ 18...32V DC
SA power	10 mA @ 0...32V DC 25 mA @ 0...240V AC, 47...63 Hz ATEX/IECEx, 125V AC Max
SA power (passthrough) ⁽¹⁾	9.95 A @ 0...32V DC 9.975 A @ 0...240V AC, 47...63 Hz ATEX/IECEx, 125V AC Max
Do not exceed 10 A current draw at the MOD or SA power RTB.	
Recommended external overcurrent protection	-
Power dissipation, max	8.5 W
Thermal dissipation, max	29 BTU/hr
Isolation voltage	250V (continuous), basic insulation type, SA and MOD power to backplane 250V (continuous), basic insulation type, SA to MOD power 250V (continuous), basic insulation type, Ethernet to backplane 250V (continuous), double insulation type, Ethernet to MOD power 250V (continuous), double insulation type, Ethernet to SA power 50V (continuous), functional insulation type, Ethernet to USB 250V (continuous), basic insulation type, USB to backplane 250V (continuous), double insulation type, USB to MOD power 250V (continuous), double insulation type, USB to SA power No isolation between Ethernet ports Type tested at 1500V AC for 60 s
Wiring category ⁽²⁾	3 - on USB port 2 - on power ports 2 - on Ethernet ports

(1) The level of Mod power or SA power current that passes through the module. This level depends on the system configuration, such as, module slot location and the other module types that are used in the system. For more information, see the controller user manuals in the [Additional Resources](#) table.

(2) Use this Conductor Category information to plan conductor routes. See the Industrial Automation Wiring and Grounding Guidelines, publication [1770-4.1](#).

For **Wiring and Installation Specifications**, see [page 39](#).

Environmental Specifications - 5069-AEN2TR

Attribute	5069-AEN2TR
Temperature, operating IEC 60068-2-1 (Test Ab, Operating Cold) IEC 60068-2-2 (Test Bb, Unpackaged Nonoperating Dry Heat) IEC 60068-2-14 (Test Na, Operating Thermal Shock)	0...60 °C (32...140 °F)
Temperature, surrounding air, max	60 °C (140 °F)

Environmental Specifications - 5069-AEN2TR

Attribute	5069-AEN2TR
Temperature, nonoperating IEC 60068-2-1 (Test Ab, Unpackaged Nonoperating Cold) IEC 60068-2-2 (Test Bb, Unpackaged Nonoperating Dry Heat) IEC 60068-2-14 (Test Na, Unpackaged Nonoperating Thermal Shock)	-40...+85 °C (-40...+185 °F)
Relative humidity IEC 60068-2-30 (Test Db, Unpackaged Damp Heat)	5...95% noncondensing
Vibration IEC 60068-2-6 (Test Fc, Operating)	5 g @ 10...500 Hz
Shock, operating IEC 60068-2-27 (Test Ea, Unpackaged Shock)	30 g
Shock, nonoperating IEC 60068-2-27 (Test Ea, Unpackaged Shock)	50 g
Emissions	IEC 61000-6-4
ESD immunity IEC61000-4-2	6 kV contact discharges 8 kV air discharges
Radiated RF immunity IEC61000-4-3	10V/m with 1 kHz sine wave 80% AM from 80...2000 MHz 10V/m with 200 Hz 50% Pulse 100% AM at 900 MHz 10V/m with 200 Hz 50% Pulse 100% AM at 1890 MHz 3V/m with 1 kHz sine wave 80% AM from 2000...2700 MHz
EFT/B immunity IEC 61000-4-4	±4 kV @ 5 kHz on power ports ±2 kV @ 5 kHz on Ethernet ports
Surge transient immunity IEC 61000-4-5	±1 kV line-line (DM) and ±2 kV line-earth (CM) on power ports ±2 kV line-earth (CM) on Ethernet ports
Conducted RF immunity IEC 61000-4-6	10V rms with 1 kHz sine wave 80% AM from 150 kHz...80 MHz on power and Ethernet ports
Voltage variation IEC 61000-4-29	10 ms interruption on MOD power port

Certifications - 5069-AEN2TR

Certifications	5069-AEN2TR
c-UL-us	UL Listed Industrial Control Equipment, certified for US and Canada. See UL File E65584. UL Listed for Class I, Division 2 Group A,B,C,D Hazardous Locations, certified for U.S. and Canada. See UL File E194810.
CE	European Union 2014/30/EU EMC Directive, compliant with: • EN 61326-1; Meas./Control/Lab., Industrial Requirements • EN 61000-6-2; Industrial Immunity • EN 61000-6-4; Industrial Emissions • EN 61131-2; Programmable Controllers (Clause 8, Zone A & B) European Union 2014/35/EU LVD, compliant with: • EN 61010-2-201; Control Equipment Safety Requirements European Union 2011/65/EU RoHS, compliant with: • EN IEC 63000; Technical documentation
RCM	Australian Radiocommunications Act, compliant with EN 61000-6-4; Industrial Emissions
Ex - When used at or below 125V AC	European Union 2014/34/EU ATEX Directive, compliant with: • EN 60079-15; Potentially Explosive Atmospheres, Protection "n" • EN 60079-0; General Requirements • II 3 G Ex nA IIC T4 Gc • DEMKO 15 ATEX 1455X
IECEX	IECEX System, compliant with: • IEC 60079-15; Potentially Explosive Atmospheres, Protection "n" • IEC 60079-0; General Requirements • II 3 G Ex nA IIC T4 Gc • IECEx UL 15.0007X When used at or below 125V AC
KC	Korean Registration of Broadcasting and Communications Equipment, compliant with Article 58-2 of Radio Waves Act, Clause 3
EtherNet/IP	ODVA conformance tested to EtherNet/IP specifications

See the Product Certification link at [rok.auto/certifications](#) for Declarations of Conformity, Certificates, and other certification details.

5069-ARM

Address Reserve Module

Functional Block Diagram - 5069-ARM

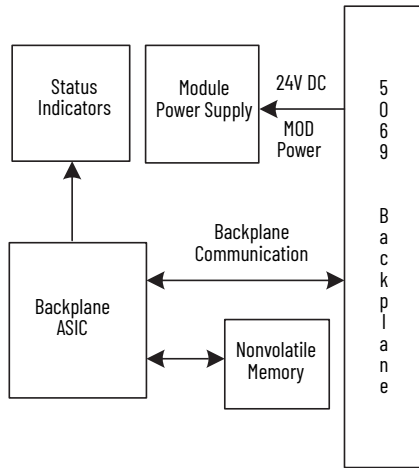

Technical Specifications - 5069-ARM

Attribute	5069-ARM
Voltage and current ratings	
MOD power	45 mA @ 18...32V DC
MOD power (passthrough) ⁽¹⁾	9.55 A @ 18...32V DC
SA power (passthrough) ⁽¹⁾	9.95 A @ 0...32V DC 9.975 A @ 0...240V AC, 47...63 Hz EX, 125V AC, max NOTE: This module does not draw SA power current.
Do not exceed 10 A MOD or SA power (Passthrough) current draw	
Power dissipation, max	1.0 W
Thermal dissipation, max	3.4 BTU/hr
Indicators	1 green/red module status indicator
<small>(1) The level of Mod power or SA power current that passes through the module. This level depends on the system configuration, such as, module slot location and the other module types that are used in the system. For more information, see the controller user manuals in the Additional Resources table.</small>	

For **Wiring and Installation Specifications**, see [page 39](#).
 For **Certifications**, see [page 40](#).
 For **Environmental Specifications**, see [page 41](#).

5069-FPD

Field Potential Distributor

Wiring - 5069-FPD

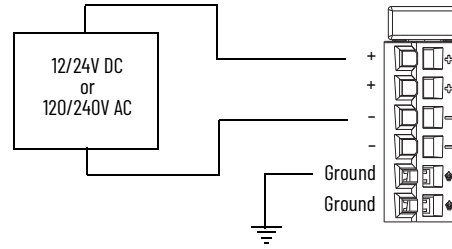

Technical Specifications - 5069-FPD

Attribute	5069-FPD
Voltage and current ratings	
MOD power (passthrough) ⁽¹⁾	9.55 A @ 18...32V DC
SA power	10 mA @ 0...32V DC 25 mA @ 0...240V AC, 47...63 Hz EX, 125V AC, max
SA power (passthrough) ⁽¹⁾	9.99 A @ 0...32V DC 9.975 A @ 0...240V AC, 47...63 Hz EX, 125V AC, max
Do not exceed 10 A MOD or SA power (passthrough) current draw	
Power dissipation, max	4.0 W
Thermal dissipation, max	13.6 BTU/hr
Isolation voltage	250V (continuous), Basic Insulation Type Type tested at 1500V AC for 60 s
Indicators	1 green module status indicator
Wire category ⁽²⁾	2 - on power ports
<small>(1) The level of Mod power or SA power current that passes through the module. This level depends on the system configuration, such as, module slot location and the other module types that are used in the system. For more information, see the controller user manuals in the Additional Resources table.</small>	
<small>(2) Use this Conductor Category information to plan conductor routes. See the Industrial Automation Wiring and Grounding Guidelines, publication 1770-4.1.</small>	

For **Wiring and Installation Specifications**, see [page 39](#).
 For **Certifications**, see [page 40](#).
 For **Environmental Specifications**, see [page 41](#).

5069-HSC2X0B4

High-speed Counter Module

Channel connections | The wiring diagrams show connections to specific channels. You are not restricted to using only those channels. You can connect to any channel or combination of channels as needed.

Differential Encoder Wiring - 5069-HSC2X0B4

We recommend that you use twisted-pair, individually shielded cable with a maximum length of 300 m (1000 ft) when connecting a differential encoder. For more information on the cable type to use, see the encoder documentation.

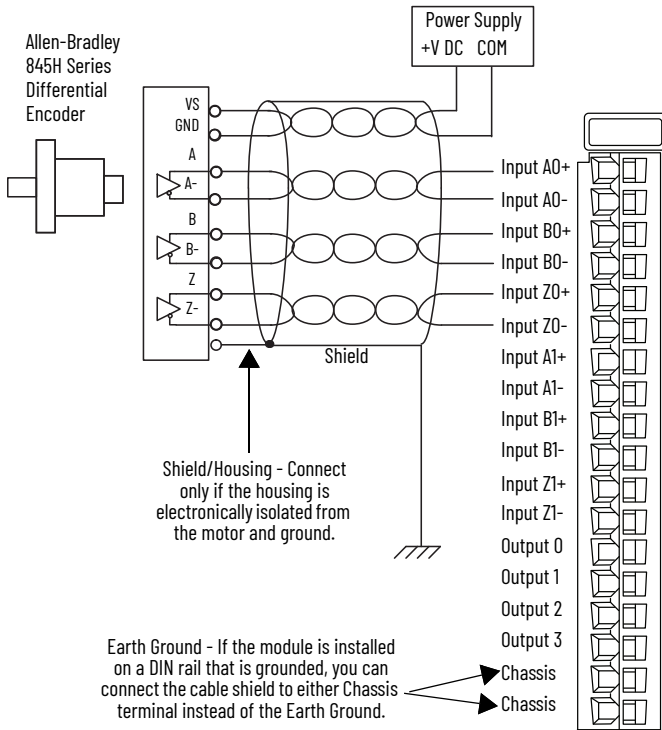

Single-ended Encoder Wiring - 5069-HSC2X0B4

We recommend that you use twisted-pair, individually shielded cable with a maximum length of 300 m (1000 ft) when you connect a single-ended encoder. For more information on the cable type to use, see the encoder documentation.

IMPORTANT: External resistors, as indicated by the "R" in the diagram, are required if they are not internal to the encoder. The pull-up resistor (R) value depends on the power supply value. The following table shows the maximum resistor values for typical supply voltages. To calculate the maximum resistor value, use the following formula:

$$R = \frac{VDC - Vmin}{Imin}$$

where:
 R = Maximum pull-up resistor value
 VDC = Power supply voltage
 Vmin = 3.0V DC
 Imin = 4.0 mA

Power Supply Voltage (V DC)	Pull-up Resistor Value (R), Max ⁽¹⁾
5	500 Ω
12	2250 Ω
24	5250 Ω

(1) Resistance values can change, depending on your application. The minimum resistor (R) value depends on the current-sinking capability of the encoder.

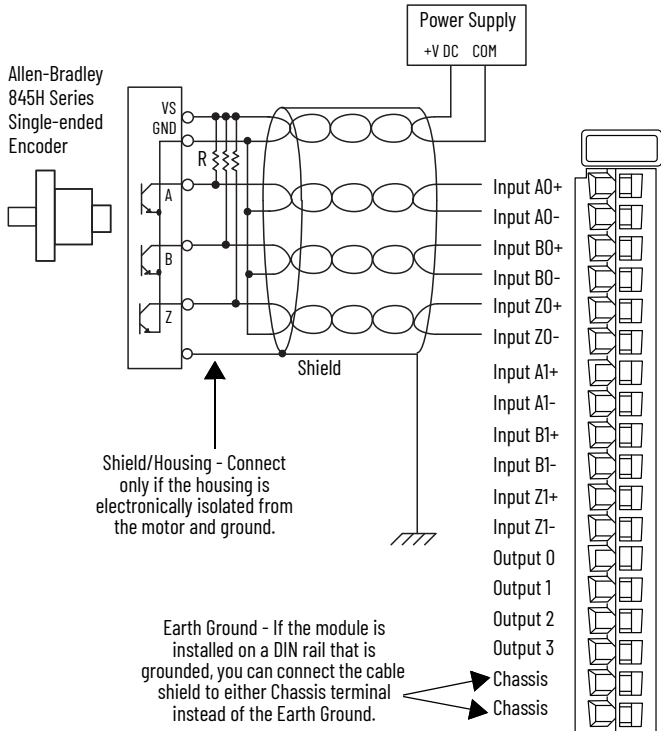

Discrete Input Device Wiring - 5069-HSC2X0B4

IMPORTANT: External resistors, as indicated by the "R" in the diagram, are required if they are not internal to the encoder. The pull-up resistor (R) value depends on the power supply value. The following table shows the maximum resistor values for typical supply voltages. To calculate the maximum resistor value, use the following formula:

$$R = \frac{VDC - Vmin}{Imin}$$

where:
 R = Maximum pull-up resistor value
 VDC = Power supply voltage
 Vmin = 3.0V DC
 Imin = 4.0 mA

Power Supply Voltage (V DC)	Pull-up Resistor Value (R), Max ⁽¹⁾
5	500 Ω
12	2250 Ω
24	5250 Ω

(1) Resistance values can change, depending on your application. The minimum resistor (R) value depends on the current-sinking capability of the encoder.

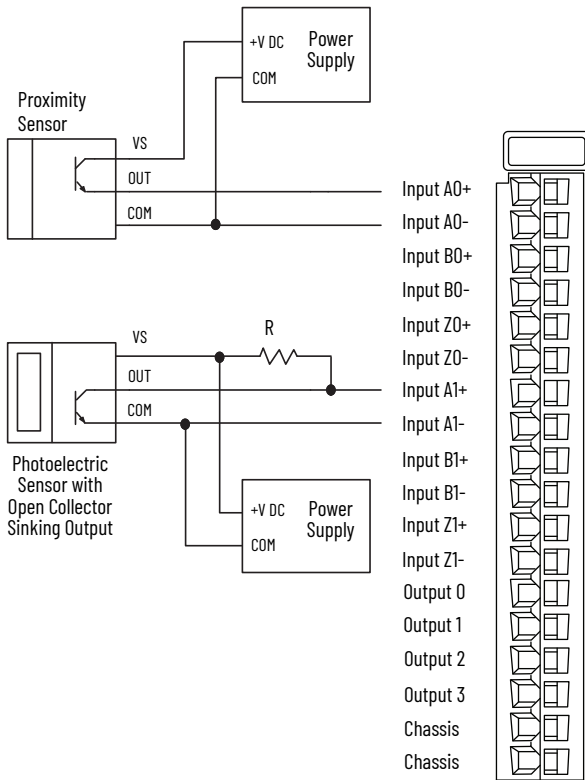

Discrete Output Device Wiring - 5069-HSC2X0B4

IMPORTANT:

- The 5069-HSC2x0B4 module uses DC SA power.
- The 5069-HSC2x0B4 module outputs use a shared common. The outputs have a return through internal module circuitry to the SA (-) terminal on the SA power RTB. For more information, see page 6.

Surge Suppression	The module has built-in suppression that is sufficient for most applications. For high-noise applications, we recommend that you use a 1N4004 diode reverse-wired across the load for transistor outputs switching 24V DC inductive loads. For additional details, see the Industrial Automation Wiring and Grounding Guidelines, publication 1770-4.1 .
SA Power	Connections to an external power supply that provides SA power via the SA power RTB on one of these devices: <ul style="list-style-type: none"> • CompactLogix 5380 controller • Compact GuardLogix 5380 controller • CompactLogix 5480 controller • 5069-AENTR EtherNet/IP Adapter • 5069-FPD field potential distributor
Isolate SA power	If you install modules in a system that uses both AC SA power and DC SA power, you must isolate SA power buses by type with a 5069-FPD field potential distributor. To create separate SA power buses, complete these steps: <ol style="list-style-type: none"> 1. Install the modules that use one type of SA power, for example DC, to the right of the adapter or controller. This is the first SA power bus. 2. To create a second SA power bus, install the 5069-FPD field module to the right of these modules. 3. Install the modules that use the other type of SA power, for example AC, to the right of the 5069-FPD module.

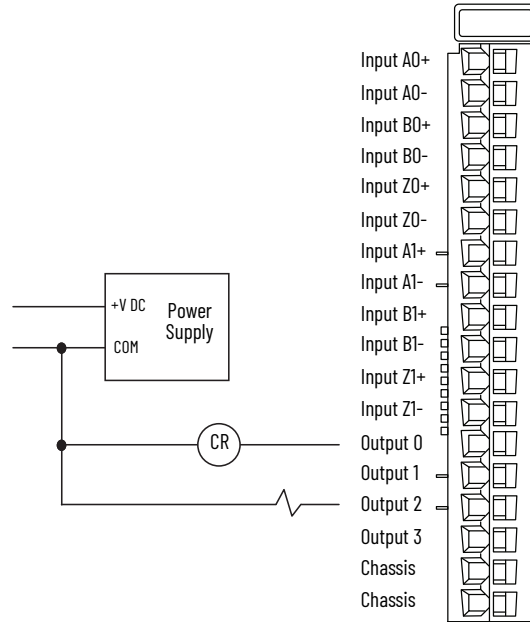

Functional Block Diagram - 5069-HSC2X0B4
Module Outputs to SA Power

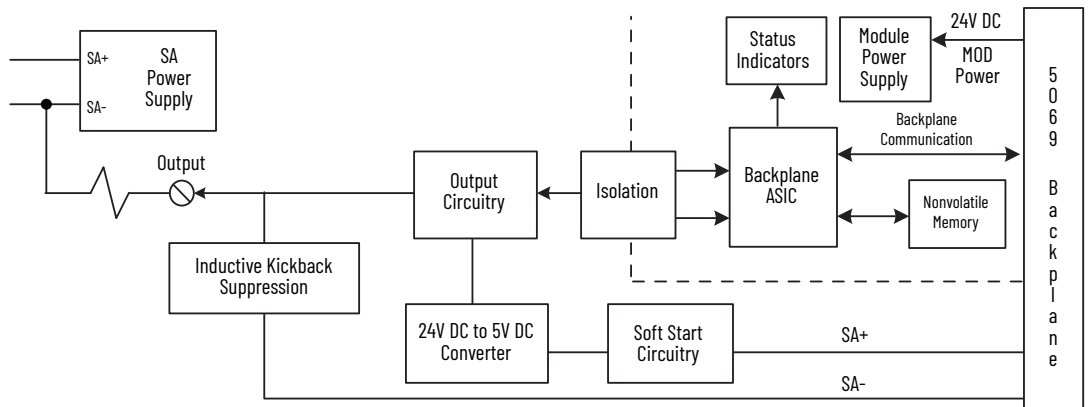

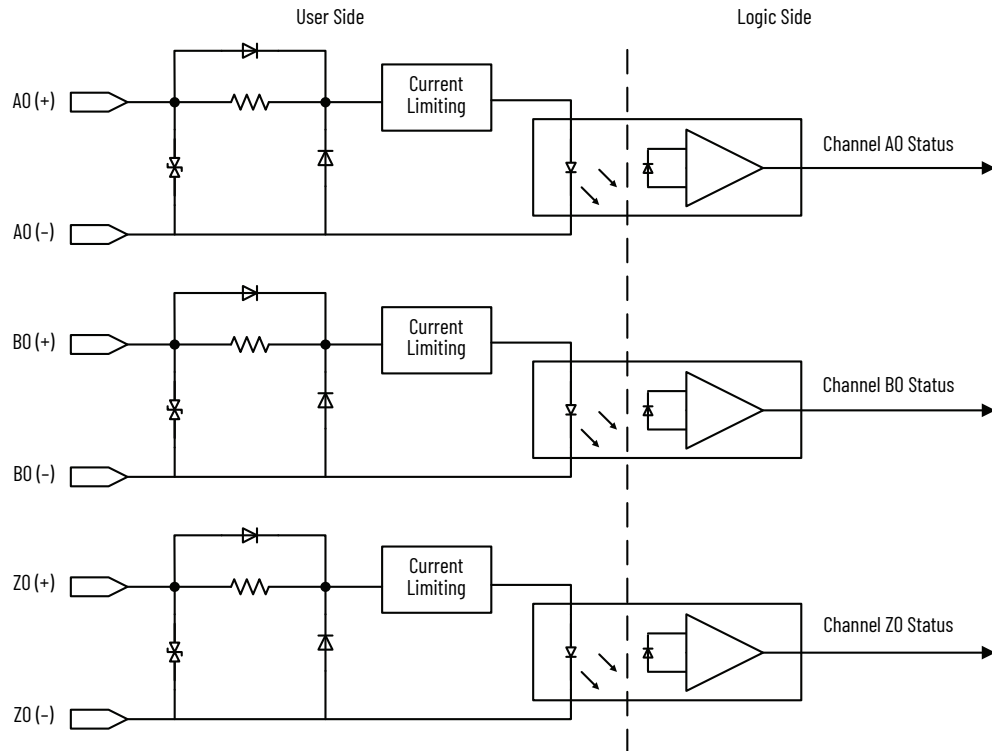

Functional Block Diagram - 5069-HSC2X0B4

Module Inputs - This is a diagram for Counter 0. Counter 1 uses the same design.

Technical Specifications - 5069-HSC2X0B4

Attribute	5069-HSC2X0B4
Inputs	2 quadrature (ABZ) differential inputs
Outputs	4 Channels (1 group of 4), sourcing
Voltage category	12/24V DC source
Voltage and current ratings	
Counter input ratings	4 mA @ 18...32V DC
MOD power	50 mA @ 18...32V DC
MOD power (passthrough) ⁽¹⁾	9.55 A @ 18...32V DC
SA power	3 A @ 18...32V DC
SA power (passthrough) ⁽¹⁾	9.95 A @ 10...32V DC
Do not exceed 10 A MOD or SA power (passthrough) current draw	
Power dissipation, max	3 W
Thermal dissipation, max	10.2 BTU/hr
Isolation voltage	300V (continuous), Basic Insulation Type No isolation between SA power and I/O ports No isolation between individual I/O ports Type tested at 1500V AC for 60 s
Indicators	1 green/red module status indicator 10 yellow/red I/O status indicator
Wiring category ⁽²⁾	2 - on shielded output ports 2 - on output power ports 2 - on shielded counter ports
Input current, max	8 mA
On-state voltage, range	3V DC...32V DC
On-state voltage, nom	24V DC
On-state voltage drop, max	< 0.3V DC
On-state current, min	4 mA
Off-state voltage, max	1.5V
Off-state current, max	1 mA
Output voltage range	10...32V DC
On-state output current, min	1 mA per channel 4 mA per module

Technical Specifications - 5069-HSC2X0B4

Attribute	5069-HSC2X0B4
Pulse width, min	125 ns
Pulse separation, min	100 ns
Reverse voltage protection	32V DC
Overvoltage protection, max	36V (fuse protected)
Features, supported	The module supports these features. <ul style="list-style-type: none"> No load detection, per channel diagnostics Output short circuit/overload/overtemp detection, per channel diagnostics Output short circuit/overload protection Pilot duty - Make current electronically limited/protected @ 3.6 A
Output control in fault state per point	
Output states in program mode per point	<ul style="list-style-type: none"> Hold last state On Off (default)
Output states in fault mode per point	
Duration of fault mode per point	<ul style="list-style-type: none"> 1, 2, 5, or 10 seconds Forever (default)

(1) The level of Mod power or SA power current that passes through the module. This level depends on the system configuration, such as, module slot location and the other module types that are used in the system. For more information, see the controller user manuals in the [Additional Resources](#) table.

(2) Use this Conductor Category information to plan conductor routes. See the Industrial Automation Wiring and Grounding Guidelines, publication [1770-4.1](#).

For **Wiring and Installation Specifications**, see [page 39](#).

For **Certifications**, see [page 40](#).

For **Environmental Specifications**, see [page 41](#).

5069-SERIAL

Serial Module

The Compact 5000 I/O serial module provides a network interface to RS-232, RS-422, and RS-485 devices.

Use the following information to wire the connector.

Communication Port Pins

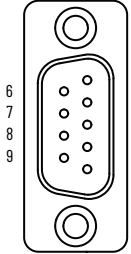

This image shows the pin layout on the 5069-serial module. See the following tables for pin descriptions, where:

– = Not Used

A = Changing signal level (Active/Inactive)

B = Fixing signal level (Active/Inactive)

SA Power	The 5069-SERIAL module does not draw current from the SA power bus. Still, the module is a DC-type module, and you must install it on a DC SA power bus.
Isolate SA power	If you install modules in a system that uses both AC SA power and DC SA power, you must isolate SA power buses by type with a 5069-FPD field potential distributor. To create separate SA power buses, complete these steps: <ol style="list-style-type: none"> 1. Install the modules that use one type of SA power, for example DC, to the right of the adapter or controller. This is the first SA power bus. 2. To create a second SA power bus, install the 5069-FPD field module to the right of these modules. 3. Install the modules that use the other type of SA power, for example AC, to the right of the 5069-FPD module.

RS-232C Pin Descriptions

Pin	RS-232C	Input (i)/Output (o) from 5069-SERIAL	Wiring	
			No Handshaking	Handshaking
1	Data Carrier Detect (DCD)	(i)	–	–
2	Receive Data (RXD)	(i)	A	A
3	Transmit Data (TXD)	(o)	A	A
4	Data Terminal Ready (DTR)	(o)	B	B
5	Common (COM)	–	A	A
6	Data Set Ready (DSR)	(i)	–	–
7	Request to Send (RTS)	(o)	B	A
8	Clear to Send (CTS)	(i)	–	A
9	–	–	–	–

RS-422 Pin Descriptions

Pin	RS-422	Input (i)/Output (o) from 5069-SERIAL	Wiring
1	–	–	–
2	Receive Data + (RXD+)	(i)	A
3	Transmit Data + (TXD+)	(o)	A
4	–	–	–
5	Common (COM)	–	A
6	–	–	–
7	Transmit Data - (TXD-)	(o)	A
8	Receive Data - (RXD-)	(i)	A
9	–	–	–

RS-485 Pin Descriptions

Pin	RS-485	Input (i)/Output (o) from 5069-SERIAL	Wiring
1	–	–	–
2	–	–	–
3	Transmit/Receive Data + (TRXD+)	(i/o)	A
4	–	–	–
5	Common (COM)	–	A
6	–	–	–
7	Transmit/Receive Data - (TRXD-)	(i/o)	A
8	–	–	–
9	–	–	–

RS-232 Connections

IMPORTANT:

If you wire the module incorrectly, the control between wiring and output signal can fail.

5069-SERIAL to DTE Device without Hardware Handshaking

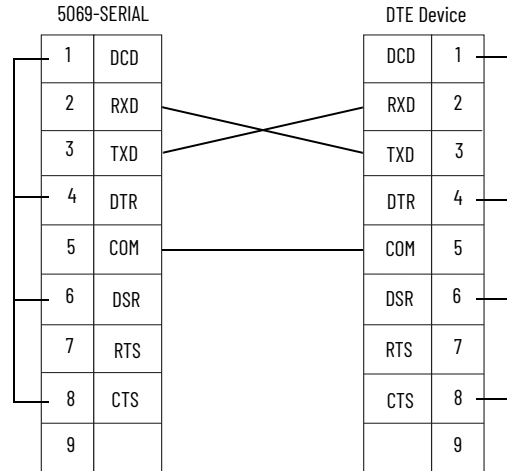

5069-SERIAL to DTE Device with "Half-duplex"

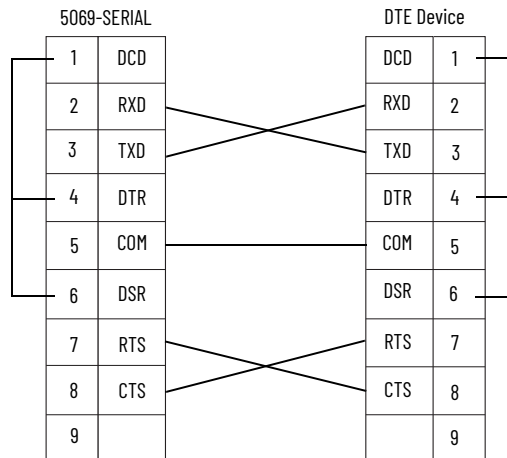

5069-SERIAL to DCE Device with "Full-duplex"

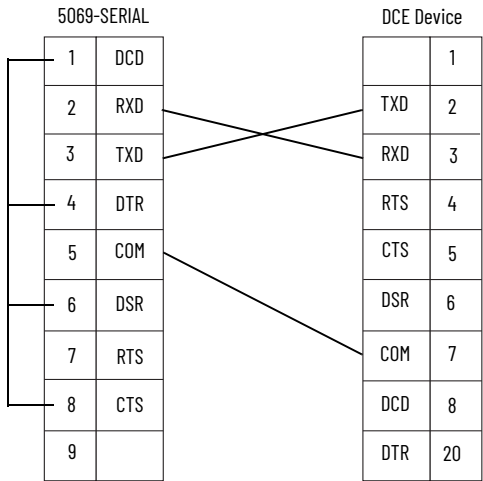

5069-SERIAL to DCE Device (Modem) with "Full or Half-duplex"

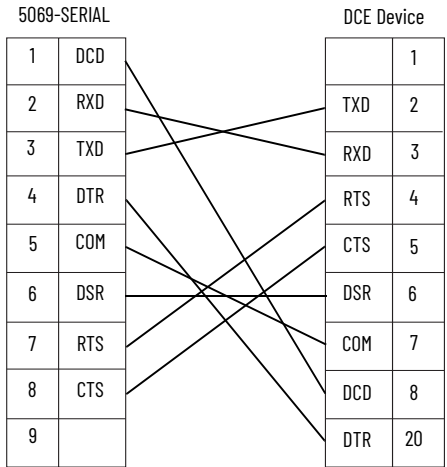

5069-SERIAL to DTE Device with "Full or Half-duplex" or Null Modem

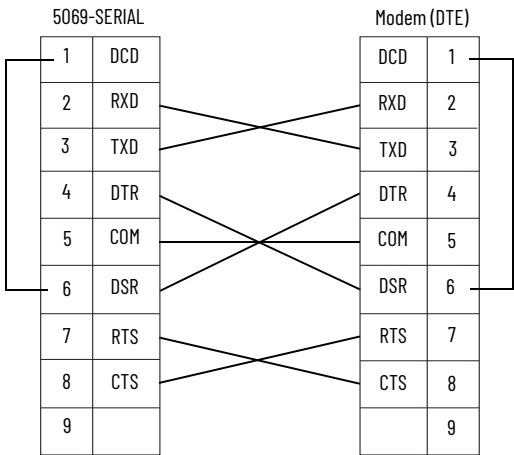

RS-422 Connections

5069-SERIAL to DTE Device

IMPORTANT:
Place the termination resistor between RXD+ and RXD- to implement this connection.

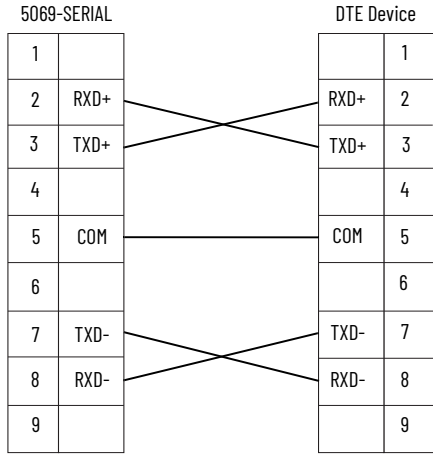

RS-485 Connections

5069-SERIAL to DTE Device

IMPORTANT:
Place the termination resistor between TRXD+ and TRXD- to implement this connection.

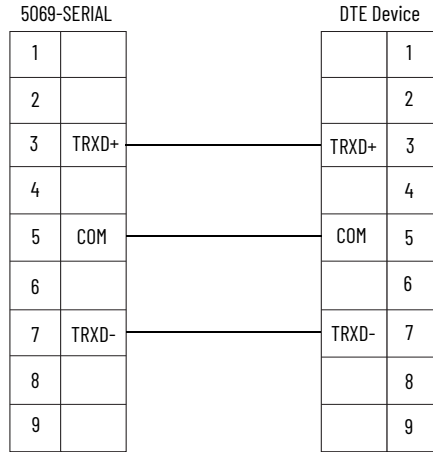

Functional Block Diagram - 5069-SERIAL

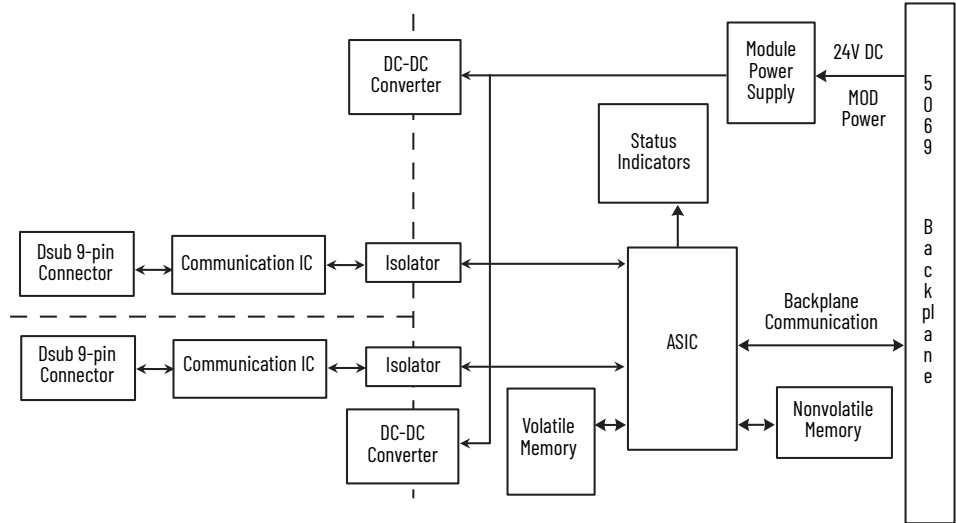

Technical Specifications - 5069-SERIAL

Attribute	5069-SERIAL
Operating modes	<ul style="list-style-type: none"> Generic ASCII Modbus RTU Modbus ASCII DF1 (local Channel 1 only) DH-485 (local Channel 1 only)
Inputs	<ul style="list-style-type: none"> 2 full-duplex (RS-232, RS-422) 2 half-duplex (RS-485)
Serial input voltage signal	<ul style="list-style-type: none"> 3...25V DC regarding signal ground (SG) 0, Asserted, ON, Space, Active -3...-25V DC regarding signal ground (SG) 1, Deasserted, OFF, Mark, Inactive
Voltage and current ratings	
MOD power	100 mA @ 18...32V DC
MOD power (passthrough) ⁽¹⁾	9.55 A @ 18...32V DC
SA power (passthrough) ⁽¹⁾	9.95 A @ 0...32V DC The module does not draw SA power current.
Do not exceed 10 A MOD or SA power (passthrough) current draw	
Power dissipation, max	2.8 W
Thermal dissipation, max	9.6 BTU/hr
Isolation voltage	250V (continuous), Basic Insulation Type, SA and MOD power to Backplane 250V (continuous), Basic Insulation Type, Backplane to Communication Channels 250V (continuous), Basic Insulation Type, Backplane to Chassis Ground 250V (continuous), Basic Insulation Type, Between Communication Channels 250V (continuous), Basic Insulation Type, SA to MOD power 250V (continuous), Basic Insulation Type, Communication Channels to Chassis Ground 250V (continuous), Basic Insulation Type, SA and MOD power to Chassis Ground 250V (continuous), Reinforced Insulation Type, SA and MOD power to Communication Channels Basic Insulation Type tested at 2100V DC for 60 s Reinforced Insulation Type tested at 4200V DC for 60 s

Technical Specifications - 5069-SERIAL

Attribute	5069-SERIAL
Transmit transaction ID	0...255
Handshaking	RTS/CTS hardware handshake always enabled. RTS/CTS can be user-controlled.
Indicators	1 green/red module status indicator 1 transmit data (TXD) and 1 receive data (RXD) yellow/red status indicator per channel
Serial port connectors	Two DB-9 male with pins
Wire category ⁽²⁾	2 - power ports 2 - communication ports
Corrosion resistance classification	ISA S71.04 G2

- (1) The level of Mod power or SA power current that passes through the module. This level depends on the system configuration, such as, module slot location and the other module types that are used in the system. For more information, see the controller user manuals in the [Additional Resources](#) table.
- (2) Use this Conductor Category information to plan conductor routes. See the Industrial Automation Wiring and Grounding Guidelines, publication [1770-4.1](#).

For **Wiring and Installation Specifications**, see [page 39](#).

For **Certifications**, see [page 40](#).

For **Environmental Specifications**, see [page 41](#).

Additional Resources

These documents contain additional information concerning related products from Rockwell Automation. You can view or download publications at rok.auto/literature.

Resource	Description
Compact 5000 I/O Digital Modules User Manual, publication 5069-UM004	Describes how to configure and operate Compact 5000™ I/O digital modules.
Compact 5000 I/O Analog Modules User Manual, publication 5069-UM005	Describes how to configure and operate Compact 5000 I/O analog modules.
Compact 5000 I/O High-speed Counter Module User Manual, publication 5069-UM006	Describes how to configure and operate the Compact 5000 I/O high-speed counter module.
Compact 5000 I/O Serial Module User Manual, publication 5069-UM003	Describes how to configure and operate Compact 5000 serial modules.
CompactLogix 5380 and Compact GuardLogix 5380 Controllers User Manual, publication 5069-UM001	Describes how to configure and operate CompactLogix™ 5380 and Compact GuardLogix® 5380 controllers.
CompactLogix 5480 Controllers User Manual, publication 5069-UM002	Describes how to configure and operate CompactLogix 5480 controllers.
Compact 5000 EtherNet/IP Adapters User Manual, publication 5069-UM007	Describes how to configure and operate the Compact 5000 I/O EtherNet/IP™ adapters.
Industrial Automation Wiring and Grounding Guidelines, publication 1770-4.1	Provides general guidelines for installing a Rockwell Automation industrial system.
Product Certifications website, rok.auto/certifications	Provides declarations of conformity, certificates, and other certification details.

Rockwell Automation Support

Use these resources to access support information.

Technical Support Center	Find help with how-to videos, FAQs, chat, user forums, Knowledgebase, and product notification updates.	rok.auto/support
Local Technical Support Phone Numbers	Locate the telephone number for your country.	rok.auto/phonesupport
Technical Documentation Center	Quickly access and download technical specifications, installation instructions, and user manuals.	rok.auto/techdocs
Literature Library	Find installation instructions, manuals, brochures, and technical data publications.	rok.auto/literature
Product Compatibility and Download Center (PCDC)	Download firmware, associated files (such as AOP, EDS, and DTM), and access product release notes.	rok.auto/pcdc

Documentation Feedback

Your comments help us serve your documentation needs better. If you have any suggestions on how to improve our content, complete the form at rok.auto/docfeedback.





Allen-Bradley, Compact 5000, CompactLogix, expanding human possibility, GuardLogix, Logix 5000, Rockwell Automation, Rockwell Software, and Studio 5000 Logix Designer are trademarks of Rockwell Automation, Inc.

CIP Sync and EtherNet/IP are trademarks of ODVA, Inc.

Trademarks not belonging to Rockwell Automation are property of their respective companies.

Rockwell Automation maintains current product environmental compliance information on its website at rok.auto/pec.

Rockwell Otomasyon Ticaret A.Ş. Kar Plaza İş Merkezi E Blok Kat:6 34752, İçerenköy, İstanbul, Tel: +90 (216) 5698400 EEE Yönetmeliğine Uygundur

Connect with us.    

rockwellautomation.com ————— **expanding human possibility®**

AMERICAS: Rockwell Automation, 1201 South Second Street, Milwaukee, WI 53204-2496 USA, Tel: (1) 414.382.2000

EUROPE/MIDDLE EAST/AFRICA: Rockwell Automation NV, Pegasus Park, De Kleetlaan 12a, 1831 Diegem, Belgium, Tel: (32) 2663 0600

ASIA PACIFIC: Rockwell Automation SEA Pte Ltd, 2 Corporation Road, #04-05, Main Lobby, Corporation Place, Singapore 618494, Tel: (65) 6510 6608

UNITED KINGDOM: Rockwell Automation Ltd., Pitfield, Kiln Farm, Milton Keynes, MK11 3DR, United Kingdom, Tel: (44)(1908) 838-800

Publication 5069-TD0010-EN-P - May 2024

Supersedes Publication 5069-TD0010-EN-P - November 2023

Copyright © 2024 Rockwell Automation, Inc. All rights reserved. Printed in the U.S.A.