

1 Position Three-Phase Cutout / Arrester Bracket (0°) with Hardware

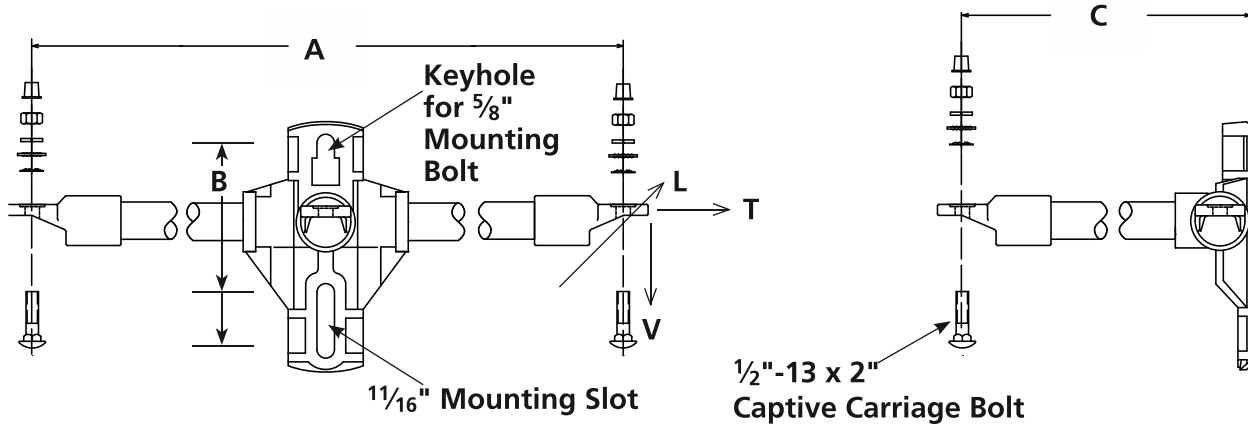

- Base design permits bolting or banding to structure.
- Base is aluminum alloy.
- B Dimension is 6" & 8"

- End Fittings are hot-dip-galvanized ductile iron.

Catalog Number	Length A	Length C	Minimum Ultimate*			Weight (Each)
			Vertical V	Longitudinal L	Transverse T	
Medium Duty 1 1/2" (38 mm) Dia. Fiberglass Rod						
3SBM3613SGLB	36" (91.4 cm)	13" (33.0 cm)	1200 lb. (544 kg)	800 lb. (363 kg)	5000 lb. (2268 kg)	11.9 lb. (5.4 kg)
3SBM3618SGLB	36" (91.4 cm)	18" (45.7 cm)	1200 lb. (544 kg)	800 lb. (363 kg)	5000 lb. (2268 kg)	12.6 lb. (5.7 kg)
3SBM4813SGLB	48" (121.9 cm)	13" (33.0 cm)	900 lb. (408 kg)	700 lb. (318 kg)	5000 lb. (2268 kg)	13.5 lb. (6.1 kg)
3SBM4818SGLB	48" (121.9 cm)	18" (45.7 cm)	900 lb. (408 kg)	700 lb. (318 kg)	5000 lb. (2268 kg)	14.1 lb. (6.4 kg)

*Recommended maximum working load is 50% of minimum ultimate ratings listed.
 Consult factory for additional lengths.
 Add "SC" suffix to the end of the catalog number to denote Silicone Coated rod