

CS
CONTRACTOR
SELECT™

Everyday Lighting Done Right™

Contractor Select™ products are simply our most popular products for the most common projects - perfect for those everyday lighting jobs.

nLIGHT

nLight® AIR wireless lighting controls are a smart solution for simplifying installation and aiding in energy code compliance.

One Lithonia Way, Conyers, GA 30012 | 770-922-9000 | www.acuitybrands.com
© 2020 Acuity Brands Lighting, Inc. All rights reserved. | LL_511517.09_0920

NORTH AMERICA'S

#1 Selling High Bay Brand

lithonialighting.com/compactpro



AcuityBrands.

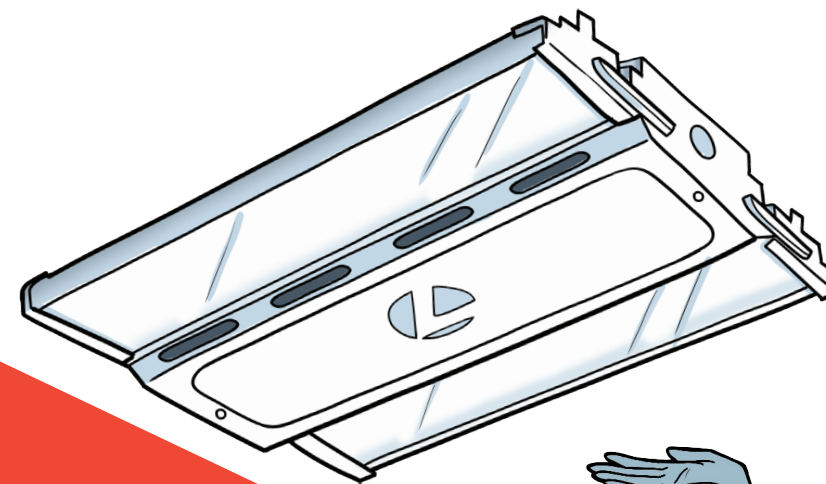

**Compact Pro
LED High Bay**

The best choice for the budget
and quality-conscious contractor

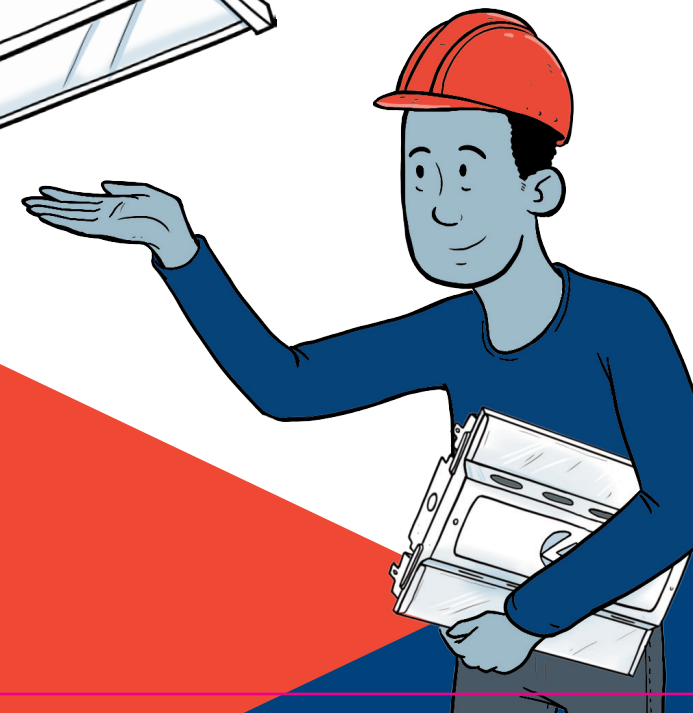

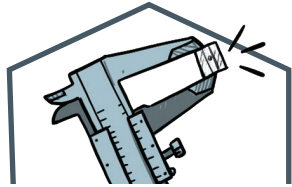

COMPACT DESIGN

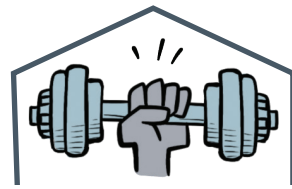

BIG HIGH BAY PERFORMANCE

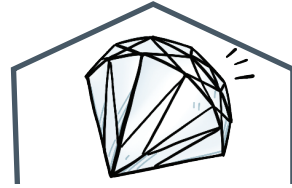

ROCK SOLID QUALITY

The Affordable High Bay You Need

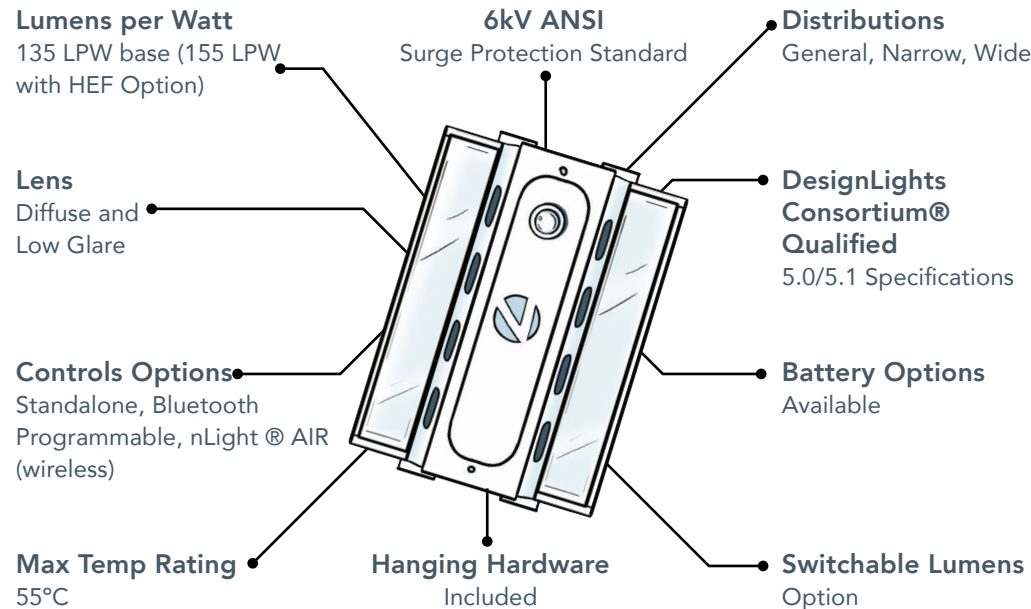

Compact Pro High Bay by Lithonia Lighting™, the **smallest** and **lightest** high bay on the market!

Other sizes available:
Size 2
22.5" L x 11.5" W x 2.2" D
24,000LM & 30,000LM *

Size 1
14" L x 11.5" W x 2.2" D
9,000LM, 12,000LM,
15,000LM & 18,000LM*

Size 3
44" L x 11.5" W x 2.2" D
36,000LM, 48,000LM,
60,000LM

*Part of Contractor Select™ program

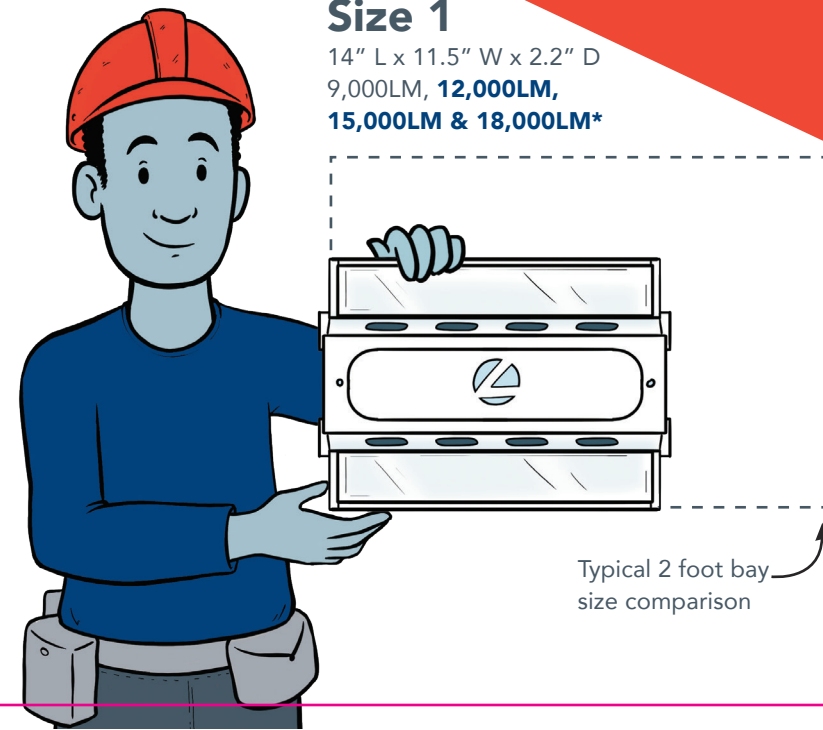

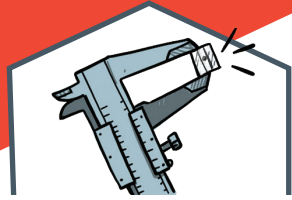

**COMPACT
DESIGN**

Slim/Compact Everyday Unit Pack

**Get the job
done easier
faster, and
cheaper!**

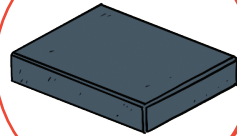

Faster staging, install,
and cleanup

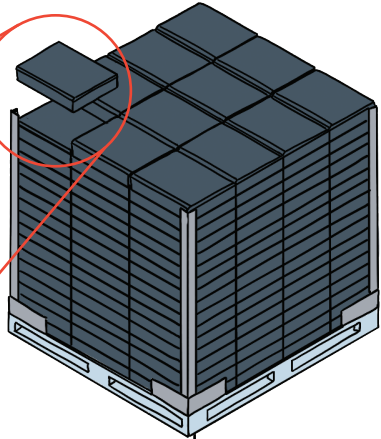

Fit up to 3X more
product on a pallet

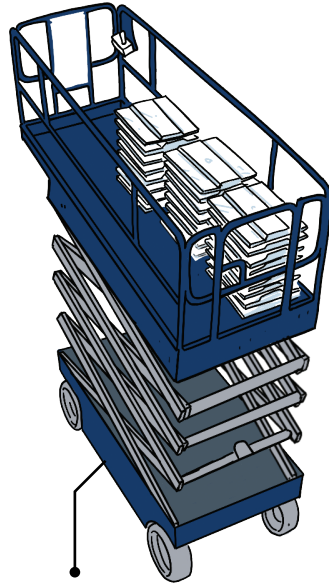

Fit up to 3X more
on a lift platform



Reduces install
time & labor up to
30%



Reduces packaging
waste by
>75%
*Size dependent

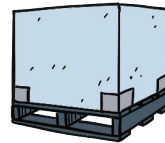

Ships with
>140
units per pallet
*Size dependent

Contractor-Friendly Job Pack

At < 6 lbs per fixture, easily
install with 1 person!

Sized to fit
scissor lift

Contractor
Approved!

Quick and easy
to access and
dispose

Trays come together
to form a neat and
organized pallet

Stackable

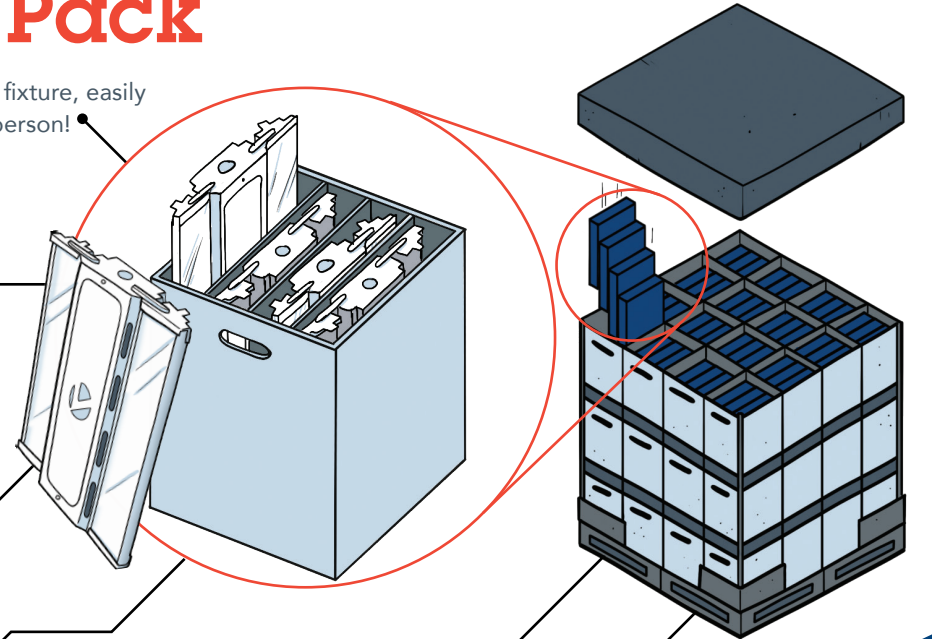



BIG HIGH BAY PERFORMANCE

Illuminates the same amount of space as fixtures 4x the length!

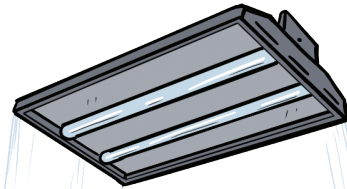

Typical 24"/48" High bay

30-50% Smaller

than typical high bays without sacrificing performance

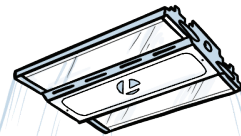

Compact Pro High Bay

Glare Control

Engineered Optics allow for comfortable illumination

DLC Qualified

Meets 5.0 and 5.1 UGR glare requirements

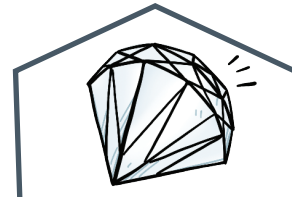

ROCK SOLID QUALITY



Typical "budget" High bay	Compact Pro High Bay	Features	Why should I care?
X	✓	Surge Protection 6kV per ANSI standards	Industrial Power Quality challenges
X	✓	True Industrial Temperature Ratings – Temp Label	Ensures fixture was tested to elevated ambient temps
X	✓	Lumen Maintenance (L70 > 100,000 hours)	Typical Budget high bays lose 30% of light within 50,000 Hours
X	✓	Quality Components	The fixture is only as reliable as its weakest component
X	✓	Trusted Name Brand	Lithonia is the #1 High Bay Brand in North America