

FEATURES

The OEC is a versatile LED strip light that can be suspended or surface mounted. Available in single pendant or continuous mounting with a form factor that ensures continuous illumination. An acrylic lens delivers low-glare, even illumination for comfortable environments. The slim 3-3/8" profile makes the OEC ideal for illuminating a variety of narrow applications such as aisles, hallways, corridors, parking garages, as well as education, healthcare, and transportation applications.

NOMINAL LUMENS	DELIVERED LUMENS	WATTAGE
5000	5272	39 W
4000	4121	30 W
3000	2978	23 W

Based on 4000K, 85+ CRI. Actual wattage may vary +/- 5%

LUMENS	3000, 4000, 5000
CCT	35K, 40K, 50K
CRI	85+
COLOR QUALITY	3 Step MacAdam Ellipse
LENGTH	2', 4' or 8'
MOUNTING	Suspended or Surface
DIMMING & CONTROL	0-10V Flicker Free 1% Dimming Standard (DIM10)
EMERGENCY	10W - Up to 1000L output (Bodine BSL310)
LIFETIME	L70 at 50,000 Hours
PHOTOMETRIC TESTS	In Accordance with IES LM79-08, LM80 and TM-30, TM-21



OPTICS & PERFORMANCE

Frosted acrylic lens provides even, shadow-free illumination. Lens has tool-less removal, ensuring easy upgrading and maintenance.

CONSTRUCTION

Heavy-duty 20-gauge cold rolled steel body, post-painted. High-gloss white finish is pre-treated with 5-stage iron phosphate coating, which provides superior paint adhesion and protection against weathering.

INSTALLATION

Surface or suspended mounting; individual or continuous row mounting (CRM). The first luminaire in the row for CRM will always be the power supply feed. After plugging in the male and female harnesses, which are supplied with each luminaire, they will easily slide together. Secure with two screws in the connecting brackets.

DRIVER ELECTRICAL INFORMATION

Powered by high-quality constant-current power LED drivers, rated for 50 to 60Hz at 120-277V input, produce less than 20% THD, and have a power factor of .90 to 1.00. Male and female 18-gauge 6 wire plug connectors are included with every luminaire to allow for simple, hassle-free continuous wiring. Each luminaire must be installed male to female.

DIMMING & DRIVER INFORMATION

DIM10 - Flicker Free 1% Dimming Standard (DIM10) 0-10V dimming on either MVOLT 120, 277V.

WARRANTY

Five-year warranty for parts and components. (Labor not included)

LISTINGS

c-UL-us - Listed for Feed Through Wiring.
Listed for DLC, California Title 24 compliant.
c-UL-us Damp location listed

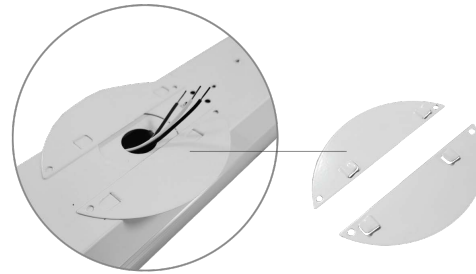

Cover for junction box is shipped standard with fixture, along with necessary hardware to secure cover to j-box.

Example: **4-OEC-LED-3000L-DIM10-MVOLT-40K-85**

4	OEC	LED																
FIXTURE SIZE	SERIES	TYPE	LUMENS	DIMMING	VOLTAGE	CCT	CRI	EMERGENCY	MOUNTING									
4 - 4'	OEC - LED General Linear	LED	3000L - 3000 lumens 4000L - 4000 lumens 5000L - 5000 lumens	DIM10 - 0-10V Dimming	MVOLT	35K 40K 50K	85	O-EMG-LED-10W	CRM - Continuous Row Mounting									

Wattstopper Lens options

FSP-L2-W	White	360° lens, maximum coverage 48' diameter from 8' height
FSP-L2-B	Black	
FSP-L2-BR	Bronze	
FSP-L2-G	Grey	
FSP-L2-S-W	White	360° lens, maximum coverage 48' diameter from 8' height, with shroud; Minimizes high-angle light contribution to photocell
FSP-L3-W	White	360° lens, maximum coverage 40' diameter from 20' height
FSP-L3-B	Black	
FSP-L3-BR	Bronze	
FSP-L3-G	Grey	
FSP-L3-S-W	White	360° lens, maximum coverage 40' diameter from 20' height, with shroud; Minimizes high-angle light contribution to photocell
FSP-L7-W	White	360° lens, maximum coverage 100' diameter from 40' height
FSP-L7-B	Black	
FSP-L7-BR	Bronze	
FSP-L7-G	Grey	
FSP-L7-S-W	White	360° lens, maximum coverage 100' diameter from 40' height, with shroud; Minimizes high-angle light contribution to photocell
FSP-C1-W	White	Small collar, for use with FSP-L2 and FSP-L3 lenses (Optional aesthetic collar to transition from fixture housing to lens) Note: Not used with lenses that include shroud
FSP-C2-W	White	Large collar, for use with FSP-L7 lens (Optional aesthetic collar to transition from fixture housing to lens) Note: Not used with lens that includes shroud

- MOUNTING**
CRM - Continuous Row Mounting
- WIRING OPTIONS**
FBF - Internal Fast Blow Fuse
SBF - Internal Slow Blow Fuse
RIS - Radio Interference Suppressor
- OTHER OPTIONS**
OCSS - Cable Gripper Suspension Kit
WG - WireGuard
USA - Made in America Compliance
S05 - Power cord with 5 conductors for 0-10v dimming fixtures
S06 - Power cord with 6 conductors for 0-10V dimming and with emergency
VHCH - V-Hook & chain
MFG-BRACKET-CR-OEC - bracket for continuous row mounting
- SIDE MOUNT CONTROL**
FSP-311-B-D - 0-10V continuous dimming PIR photo/motion sensor with bluetooth control option.

4-OEC-LED-3000L-DIM10-MVOLT-40K-85

INPUT WATTS: 22.5

LUMENS: 2978

CRI: 90

EFFICACY: 132

CCT: 4000K

TEST NO.: EL1118106

SPACING CRITERIA: 1.40

Candle Power Distribution (Candelas)

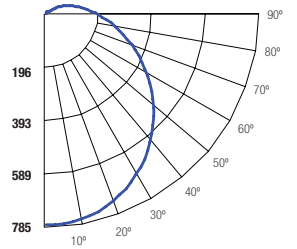

Zonal Lumens Summary

Zone	Lumens	%Lamp	%Fixt
0-20	286.62	N.A.	9.60
0-30	608.72	N.A.	20.40
0-40	999.01	N.A.	33.60
0-60	1801.65	N.A.	60.50
0-80	2399.03	N.A.	80.60
0-90	2587.3	N.A.	86.90

Luminance (Average candela/M²)

Angle in Degrees	Average		
	0°	45°	90°
45	5505	5055	4382
55	5861	5163	4041
65	6636	5582	3608
75	8739	6978	2979
85	20327	15352	2109

Lumens Per Zone

Zone	Lumens
0-10	74.21
10-20	212.41
20-30	322.10
30-40	390.29
40-50	412.12
50-60	390.51
60-70	335.46
70-80	261.92
80-90	188.27

Candela Tabulation

0	
0	784.740
5	783.245
15	763.018
25	722.774
35	664.915
45	593.587
55	512.717
65	427.699
75	344.947
85	270.182
90	237.398

Coefficients of Utilization - Zonal Cavity Method

Effective Floor Cavity Reflectance 0.20

ROOM CAVITY RATIO	RC	80%				70%				50%				30%				10%				0%			
		RW	70%	50%	30%	10%	70%	50%	30%	10%	50%	30%	10%	50%	30%	10%	50%	30%	10%	50%	30%	10%	0%		
0	116	116	116	116	116	112	112	112	112	104	104	104	97	97	97	90	90	90	90	90	90	90	87		
1	103	98	93	88	88	99	94	90	85	87	84	80	81	78	75	76	73	71	68	68	68	68	68		
2	93	84	76	70	70	89	81	74	68	75	70	65	70	65	61	65	61	58	55	55	55	55			
3	85	73	64	57	57	81	71	63	56	66	59	53	61	56	51	57	52	48	45	45	45	45			
4	77	65	48	41	41	74	62	54	47	58	51	45	54	48	43	50	45	41	38	38	38	38			
5	71	57	48	41	41	68	56	47	40	52	44	39	48	42	37	45	40	35	33	33	33	33			
6	65	52	42	36	36	62	50	41	35	47	39	34	44	37	32	41	35	31	29	29	29	29			
7	60	47	38	31	31	58	45	37	31	42	35	30	40	33	29	37	32	27	25	25	25	25			
8	56	42	34	28	28	54	41	33	27	39	32	26	36	30	25	34	29	25	22	22	22	22			
9	52	39	31	25	25	50	38	30	24	36	29	24	34	27	23	32	26	22	20	20	20	20			
10	49	36	28	22	22	47	35	27	22	33	26	21	31	25	21	29	24	20	18	18	18	18			

RC - Ceiling Cavity Reflectance

RW - Wall Reflectance

Cone of Light

Beam Dia. (ft)	Initial Footcandle at Nadir	Beam Vert. Spread	Beam Horiz. Spread
2	204	10	5.1
4	51.1	20	10.3
6	22.7	29.9	15.4
8	12.8	39.9	20.5
10	8.17	49.9	25.6
12	5.68	59.9	30.8

BEAM DIA. MEASURED AT 50% OF NADIR F.C.

4-OEC-LED-4000L-DIM10-MVOLT-40K-85

INPUT WATTS: 30.5

LUMENS: 4121

CRI: 85

EFFICACY: 135

CCT: 4000K

TEST NO.: EL0119166

SPACING CRITERIA: 1.40

Candle Power Distribution (Candelas)

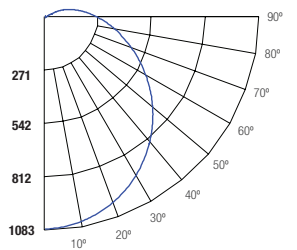

Zonal Lumens Summary

Zone	Lumens	%Lamp	%Fixt
0-20	394.07	9.60	9.60
0-30	836.91	20.30	20.30
0-40	1376.77	33.40	33.40
0-60	2489.16	60.40	60.40
0-80	3318.23	80.50	80.50
0-90	3580.00	86.90	86.90

Luminance (Average candela/M²)

Angle in Degrees	Average		
	0°	45°	90°
45	7567	8270	9107
55	6952	8178	9645
65	6294	8596	10850
75	5204	10548	14235
85	3547	22346	33452

Lumens Per Zone

Zone	Lumens
0-10	102.07
10-20	292.00
20-30	442.84
30-40	539.86
40-50	571.28
50-60	541.11
60-70	465.14
70-80	363.93
80-90	261.77

Candela Tabulation

0	
0	1079.418
5	1073.010
15	1024.270
25	932.440
35	804.110
45	656.790
55	489.460
65	326.500
75	165.330
85	37.950
90	6.360

Coefficients of Utilization - Zonal Cavity Method

Effective Floor Cavity Reflectance 0.20

ROOM CAVITY RATIO	RC	80%				70%				50%				30%				10%				0%			
		RW	70%	50%	30%	10%	70%	50%	30%	10%	50%	30%	10%	50%	30%	10%	50%	30%	10%	50%	30%	10%	0%		
0	116	116	116	116	116	112	112	112	112	104	104	104	97	97	97	90	90	90	90	90	90	90	87		
1	103	98	93	88	88	99	94	90	85	87	84	80	81	78	75	76	73	71	68	68	68	68	68		
2	93	84	76	70	70	89	81	74	68	75	70	65	70	65	61	65	61	58	55	55	55	55	55		
3	85	73	64	57	57	81	71	63	56	66	59	53	61	56	51	57	52	48	45	45	45	45	45		
4	77	65	48	41	41	74	62	54	47	58	51	45	54	48	43	50	45	41	38	38	38	38	38		
5	71	57	48	41	41	68	55	47	40	52	44	39	48	42	37	45	40	35	33	33	33	33	33		
6	65	51	42	36	36	62	50	41	35	47	39	34	44	37	32	41	35	31	29	29	29	29	29		
7	60	47	38	31	31	58	45	37	31	42	35	30	40	33	28	37	32	27	25	25	25	25	25		
8	56	42	34	28	28	54	41	33	27	39	31	26	36	30	25	34	29	24	22	22	22	22	22		
9	52	39	30	25	25	50	38	30	24	36	29	24	34	27	23	32	26	22	20	20	20	20	20		
10	49	36	28	22	22	47	35	27	22	33	26	21	31	25	21	29	24	20	18	18	18	18	18		

RC - Ceiling Cavity Reflectance

RW - Wall Reflectance

Cone of Light

Beam Dia. (ft)	Initial Footcandle at Nadir	Beam Vert. Spread	Beam Horiz. Spread
2	270	5.2	10.1
4	67.5	10.4	20.2
6	30	15.5	30.3
8	16.9	20.7	40.4
10	10.8	25.9	50.5
12	7.5	31.1	60.6

BEAM DIA. MEASURED AT 50% OF NADIR F.C.

4-OEC-LED-5000L-DIM10-MVOLT-40K-85

INPUT WATTS: 39.4

LUMENS: 5272

CRI: 85

EFFICACY: 134

CCT: 4000K

TEST NO.: EL0119165

SPACING CRITERIA: 1.40

Candle Power Distribution (Candelas)

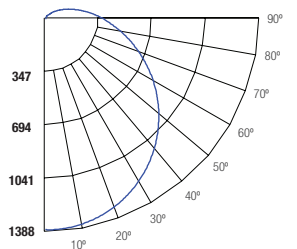

Zonal Lumens Summary

Zone	Lumens	%Lamp	%Fixt
0-20	505.28	9.60	9.60
0-30	1072.89	20.40	20.40
0-40	1760.73	33.40	33.40
0-60	3180.94	60.30	60.30
0-80	4242.47	80.50	80.50
0-90	4577.39	86.80	86.80

Luminance (Average candela/M²)

Angle in Degrees	Average		
	0°	45°	90°
45	12235	11203	9647
55	13068	11483	8908
65	14833	12426	7976
75	19517	15496	6653
85	45232	34310	4338

Lumens Per Zone

Zone	Lumens
0-10	130.87
10-20	374.41
20-30	567.61
30-40	687.83
40-50	727.72
50-60	692.50
60-70	596.09
70-80	465.43
80-90	334.92

INTEGRATED SENSOR AND CONTROL OPTIONS

With the integration of controls, Elite Lighting now offers its products with controls-ready performance that increases energy efficiency, smarter space planning, and the enhancement of safety and productivity in the workplace. By utilizing these controls, Elite Lighting luminaires enable your customer's facility to run smarter, with the use of an easily controlled system through any platform.

Luminaire will be shipped with Powerpacks pre-installed, ready to be integrated to designated control systems

Luminaire will be shipped with Sensors installed on the luminaire, allowing for individual luminaire control. Luminaires will be ready to be integrated with designated control systems

Luminaire will be shipped with Sensors to be remotely installed on the ceiling. Luminaires will be ready to be integrated with designated control systems

BRAND	
PIR INTEGRATED SENSOR	<input type="checkbox"/> FSP-311-B-D 0-10V continuous dimming PIR photo/motion sensor with bluetooth control option.

SIDE MOUNT

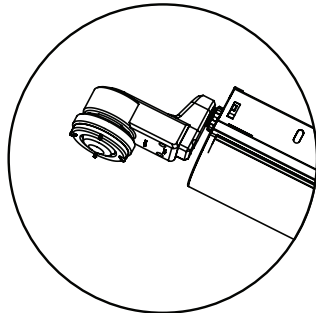

LEGRAND

FSP-311-B-D
 0-10V continuous dimming PIR photo/motion sensor with bluetooth control option.