

# Section 4

## Power Monitoring and Control



EcoStruxure Power Monitoring Expert Software

ION9000 Power and Energy Meters



PowerLogic PM8000 Power and Energy Meters



AccuSine PCS+

AccuSine PFV+

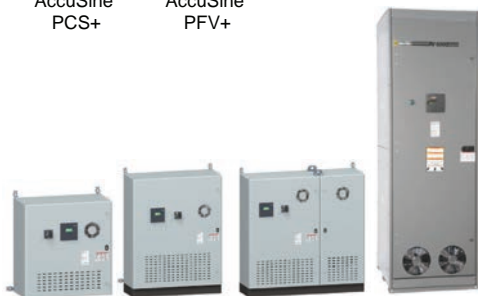

VarSet Low-Voltage Capacitor Banks

### PowerLogic™ Energy and Power Management Systems 4-2

Power Monitoring Software	4-4
EcoStruxure™ Power Monitoring Expert Software	4-4
EcoStruxure™ Power Operation	4-5
Power Quality Meters — Selection	4-6
Power Quality Meters — ION9000	4-7
ION9000 Series Advanced Power Quality Meters	4-7
Power Quality Meters — ION8650	4-9
PowerLogic™ ION7400 Utility Feeder Meter	4-11
PowerLogic PM8000 Advanced Power Quality Meters	4-13
Power and Energy Meters	4-15
Series PM5000 Power Meters	4-15
Series PM2000 Power Meters	4-15
PowerLogic™ EM3500 Power and Energy Meters	4-16
PowerLogic™ EM3570 Power and Energy Meters	4-17
PowerLogic™ PM3000 Power and Energy Meters	4-18
iEM3000 Energy Meters	4-18
Power and Energy Meter Selection	4-21
PowerLogic™ EM4200 Enercept Meter	4-22
Multi Circuit Energy Meters	4-23
PowerLogic Branch Circuit Power Meter	4-24
PowerLogic™ EM4900 Series Multi-Circuit Meters	4-26
Communications—EcoStruxure™ Panel Server	4-27
EcoStruxure™ Panel Server	4-27
Engineering, Maintenance, and Training Services	4-29
Integration and Equipment	4-33
System Integration	4-33
Factory Assembled Equipment	4-34

### Power Quality Improvement Solutions 4-36

Power Factor Correction	4-37
PowerLogic™ PFC Smart Cap Banks	4-37
PowerLogic™ PFC Smart Cap Banks	4-38
PowerLogic™ PFC	4-39
AccuSine PFV+ Electronic VAR Control	4-40
AccuSine Current Transformers	4-41
VarSet Hybrid	4-43
Harmonic Filtration	4-44
AccuSine PCS+ Active Harmonic Filter (AHF)	4-44
AccuSine PCSn Active Harmonic Filter (AHF)	4-45
PowerLogic™ AccuSine™ EVC+	4-46

POWER MONITORING AND CONTROL

4

## Join the Next Generation of Power and Energy Management

**More performance. More intelligence. More integration.**

Our industry-leading systems offer the latest in technological advancements to help you simultaneously maximize reliability, availability, and quality, as well as improve operational and cost efficiency for your entire enterprise. You'll benefit from:

- Holistic approach**  
 Our solutions aggregate data from all your energy assets, including power, building, and process systems, into one user-friendly view so you can make more informed decisions and address problems efficiently.
- Actionable intelligence**  
 Our solutions provide real-time and historical information to multiple stakeholders anywhere in the world, including easy-to-use analytics, alarms and controls, as well as regulatory compliance and financial reporting.
- Proactive capabilities**  
 Our sophisticated products help you analyze and identify future needs so you can develop a long-term plan for things like energy purchasing, demand response, load changes, and equipment maintenance or replacement.



### Advanced Power Management

Delivers power quality, availability, and reliability

- Maximize facility uptime by reducing power outages and ensuring back-up power generation
- Verify reliable power equipment operation and proactively optimize power networks
- Improve power reliability, availability, and quality through proactive analytics and diagnostics
- Optimize existing infrastructure capacity and avoid over-building
- Prolong asset life with proactive maintenance and optimization
- Reduce peak demand and power factor penalties with monitoring, alerts, and corrective actions
- Deliver enhanced network protection and control with data integration and automation



### Superior Energy Management

Delivers cost and operational efficiencies

- Identify, prioritize, and verify savings through automated load management, benchmarking, and progress reporting
- Improve sustainability performance with greenhouse gas emissions tracking and industry compliance reporting
- Improve rates with energy suppliers through demand response programming
- Confirm ROI for system improvements with advanced reporting and analysis
- Identify billing discrepancies and avoid contract penalties by validating utility bills and confirming onsite generation benefits
- Encourage conservation among tenants, departments, and processes through cost allocation reporting

### Don't settle for fragmented views and unreliable data

Maximize performance with a fully integrated power management solution

You'll benefit from our decades of expertise in electrical system management, hardware and software development, and integration. Our solutions are designed for compatibility so your installation is both optimized and more efficient. Our systems are modular and interoperable for better continuity of supply, enhanced safety for people and equipment, and more effective monitoring and control. Plus, our full range of in-person and remote services keep your system operating at peak performance.

Application

	Data Presentation & Management		Data Acquisition, Alarms & Monitoring			
	Enterprise	Online Energy Analysis	Supervisory Control & Data Acquisition	Power Monitoring System	Tenant Submetering	
	Data Centers; Industrial Buildings, Property Management, Utilities	Utilities	Water/Wastewater, Heavy Process Industry, Data Centers, Critical Power	Industrial, large commercial buildings, Military Bases, Healthcare	Commercial Buildings, Government Buildings, Military Bases	
Cost Management	Meter Application					
	Automatic Meter Reading			.	....	..
	Revenue Metering			.	....	..
	WAGES Utility Pulses				...	
	Sub-billing	...	...			....
	Measurement & Verification	....	..		...	
	Cost Allocation & Utility Billing					
	Energy Usage Analysis	....	...	.		.
	Procurement Optimization	..	...	.		
	Allocate Energy Costs	.				
	Interval Benchmarking & Profiling	....	...	.	..	
	Total Load Aggregation	....				
	Energy Efficiency					
	Emissions Tracking	..	...			
	Power Factor Correction	.	.		...	
	Peak Demand Reduction	..	.	...	...	
Demand Response & Curtailment			...	...		
Ensure Power Quality	Improve Maintenance Practices					
	Commissioning & Troubleshooting			...	....	
	Equipment Monitoring: transformers, MCCs, switchgear, switchboards, circuit breaker status, protective equipment, capacitors, generators, panelboards, PDU, UPS, etc.			...	....	
	Facility Planning					
	Identify Equipment Capacity				...	
	Determine Transformer Stress				...	
	Equipment Asset Optimization	..		..	...	
	Improve Efficiency					
	Balance Circuit Loading				...	
	Balance Generator Usage				...	
Optimize Chiller & Mechanical Equipment				.		
Network Management	System Monitoring & Analysis					
	Transient Voltage Detection				....	
	Sag/Swell Disturbance Monitoring				....	
	Power Quality & Harmonic Analysis				....	
	Power Quality Compliance	....		.	...	
	Alarm & System Diagnostics					
	Electrical Distribution Alarm & Event Analysis	.		...	....	
	Waveform capture viewing				....	
Remote alarm notification			....	...		
Engineering, Maintenance, and Training Services	Energy Services					
	Total Energy Control Services	....	see Engineering, Maintenance, and Training Services, page 4-29		...	see Engineering, Maintenance, and Training Services, page 4-29
	Peak Shaving/Generator Control	see Engineering, Maintenance, and Training Services, page 4-29		....	..	see Engineering, Maintenance, and Training Services, page 4-29
	Load Management/Shedding			....	..	
	WAGES				...	
	Advanced Reliability Services					
	Auto Throw Over (ATO)			....	..	see Engineering, Maintenance, and Training Services, page 4-29
	Emergency Power Supply System Test Reporting				....	
	Sequence of Events Recording (1ms time/stamp)	see Engineering, Maintenance, and Training Services, page 4-29		....	...	
	GPS Time Stamping			....	...	
	Power System Control			....	.	
	Network Protection			....	..	
	Consulting Services					
System Studies (SC/TCC/Arc Flash)	see Engineering, Maintenance, and Training Services, page 4-29					
Power System Assessments						



- Manage power quality, availability, and reliability
- Optimize use of your electrical and infrastructure assets
- Drive energy efficiency initiatives and improve financial performance

## EcoStruxure™ Power Monitoring Expert Software

### EcoStruxure Power Monitoring Expert

EcoStruxure™ Power Monitoring Expert is an integrated power & energy management software platform that enables you to optimize your power distribution infrastructure, maximize operational efficiency, and improve your bottom-line performance. This complete, interoperable, and scalable solution will help you

- Maximize facility uptime and reliability
- Analyze and mitigate power quality related issues
- Track and optimize equipment performance
- Analyze energy consumption, uncover savings opportunities and accurately allocate energy related costs
- Enable compliance with power quality and energy standards such as ANSI/IEEE and ISO50001

#### Typical Applications

- Monitor the facility electrical network to verify reliable operation and proactively optimize performance
- Maximize facility uptime by improving response to power-related events and restore operations quickly
- Perform root cause analysis to power-related disturbances through sequence of events reporting
- Analyze and isolate the source of power quality problems
- Analyze total energy use from all electrical and piped utilities identify waste and reduce cost
- Improve sustainability performance with greenhouse gas emissions tracking and industry compliance reporting
- Identify billing discrepancies and avoid contract penalties by validating utility bills to verify accuracy
- Allocate energy costs to departments to drive accountability, awareness and support energy action programs like ISO50001
- Reduce peak demand and power factor penalties with monitoring, alerts, and corrective actions
- Negotiate rates with energy suppliers and enable participation in demand response programs
- Confirm return on investment for infrastructure improvements with advanced reporting and analysis
- Optimize existing infrastructure capacity and avoid over-building
- Prolong asset life with proactive maintenance and optimization

#### Functional Components:

- Power quality analytics
  - Monitor events and waveform plotting system-wide
  - Monitor harmonics, K-factor, crest factor, symmetrical components
  - Diagnose and isolate PQ problems to increase reliability
  - Automatically detect and report on voltage disturbances
  - Quickly evaluate PQ events plotted on standard ITIC curve
- Customized real-time monitoring
  - Access real-time status of sensitive power distribution components
  - Trend chart tools with customized views to reveal patterns and anomalies quickly
- Data analytics and visualization
  - Smart dashboards with configurable presentation widgets and kiosk options
  - Powerful graphics templates and libraries
  - Automated power quality reports and waveform analysis tools
  - Comprehensive templates for energy and power reporting, with flexible report distribution options
- Alarm and event management
  - Powerful alarm triggering, notification, and analysis tools
  - Accurate time-stamped sequence of events reporting for power system event root cause analyses
- Robust technical infrastructure
  - Solid data acquisition architecture including ready-to-use communications drivers with many electrical distribution devices
  - Fully compatible with current operating systems and databases
  - Interoperable with integration to other systems and devices through open data and protocol standards (ODBC, OPC, XML, Modbus, Web/SOAP Services)
  - Scalable to thousands of metered points through flexible deployment options



#### Modular Design:

Power Monitoring Expert also features many application modules that add specific functionality to extend the base platform. Available modules include

- Energy Analysis
- UPS Performance
- Breaker Performance
- Energy Cost Allocation & Billing
- Automated Generator Testing

**Power Monitoring Expert:**

Description	Catalog Number
Power Monitoring Expert Standard Edition BASE license (includes 1 Engineering Client)	PSWSANCZZSPEZZ
Capacity Management Module	PSWMPNCZZSPEZZ
Backup Power Module	PSWMANCZZSPEZZ
Energy Analysis Reports Module	PSWMZNCZZSPEZZ
Energy Billing Module	PSWMBNCZZSPEZZ
Event Notification Module	PSWMMVNCZZSPEZZ
Breaker Performance Module	PSWMXNCZZSPEZZ
Power Quality Performance Module	PSWPQACZZSPEZZ
Energy Analysis Dashboard Module	PSWGENCZZSPEZZ
5 Device Pack for Power Monitoring Expert software	PSWDANCZZNPEZZ
25 Device Pack for Power Monitoring Expert software	PSWDBNCZZNPEZZ
50 Device Pack for Power Monitoring Expert software	PSWDCNCZZNPEZZ
100 Device Pack for Power Monitoring Expert software	PSWDDNCZZNPEZZ
200 Device Pack for Power Monitoring Expert software	PSWDFNCZZNPEZZ
Unlimited Devices for Power Monitoring Expert software	PSWDZNCZZSPEZZ
Client Access License for Power Monitoring Expert software	PSWCENCZZNPEZZ
Unlimited Clients Access License for Power Monitoring Expert software	PSWCZNCZZSPEZZ
Event Notification Module for Power Monitoring Expert software	PSWMMVNCZZSPEZZ
Energy Billing Module for Power Monitoring Expert software	PSWMBNCZZSPEZZ
Breaker Performance Module for Power Monitoring Expert software	PSWMXNCZZSPEZZ
Energy Analysis Module for Power Monitoring Expert software	PSWMZNCZZSPEZZ
Energy Awareness Module for Power Monitoring Expert software	PSWMMYNCZZSPEZZ
SQL Server License - 2 COREs 2022	PSWSQL2022L

**EcoStruxure™ Power Operation**

- Increase uptime of power systems
- Provides accurate and actionable information in real time
- Highlights issues, remediation, and their impacts

EcoStruxure™ Power Operation (EPO) is electrical distribution network monitoring and control software that provides vital tools to enhance your power system reliability and operational efficiency. Its powerful architecture combines our proven expertise in electrical distribution with the speed and control of high-performance to reduce outages while increasing power system efficiency. An excellent fit for virtually every industry and application, Power Operation delivers exceptional scalability so that it can grow to match your changing business requirements while driving down the total cost of ownership. Components interact seamlessly across Schneider Electric's extensive product portfolio and third party suppliers.

- Dynamic electrical network view to improve production, reduce costs and boost safety
- Highly reliable monitoring and control tailored to unique electrical network needs
- Detailed electrical information across the multi-vendor network
- Fast issue resolution and reporting to improve electrical network quality and energy use
- Report KPIs, energy costs, and filtered alarming
- Real-time visualization of the network
- Disturbance waveform views for analysis and control for remediation

For quoting and pricing, please contact PowerLogic™ Sales at 615-287-3535.



Power Quality Meter Selection

Features [1]	ION9000	ION9000T	ION8650			ION7400	PM8000
			A	B	C		
<b>Inputs, outputs and control power</b>							
3-phase / single-phase	• / •	• / •	• / •	• / •	• / •	• / •	• / •
Digital in and out / analog in and out	46 / 24	46 / 24	16 / 4	16 / 4	16 / 4	36 / 24	36 / 24
Power supply options	AC / -	AC / -	AC/DC	AC/DC	AC/DC	AC/DC	AC/DC
<b>Power and energy measurements</b>							
Voltage, current, frequency, power factor	•	•	•	•	•	•	•
Power / Demand	•	•	• / •	• / •	• / •	• / •	• / •
Energy / time-of-use (energy per shift)	• / •	• / •	• / •	• / •	• / •	• / •	• / •
IEC / ANSI energy accuracy class (% of reading)	0.1	0.1	0.2(1)	0.2(1)	0.2(1)	0.2	0.2
Loss compensation	•	•	•	•	•	•	-
<b>Power quality analysis</b>							
EN50160 compliance reporting / IEC 61000-4-30 Class A or S	• / A	• / A	• / A	• / S	- / -	• / A[2]	• / S
Flicker measurement	•	•	•	•	-	•[3]	-
Transient detection duration	20 µs	100 ns	17 µs	-	-	-	-
Sag and swell monitoring / disturbance direction detection	• / •	• / •	• / -	• / -	• / -	• / •[4]	• / •
Harmonic distortion: total/ individual / inter	• / • / •	• / • / •	• / • / •	• / • / -	• / • / -	• / • / -	• / • / -
Waveform capture	•	•	•	-	-	•	•
Rapid Voltage Change	•	•	-	-	-	•	•
<b>On-board data and event logging</b>							
Trending / forecasting / billing	• / • / •	• / • / •	• / - / •	• / - / •	• / - / •	• / • / •	• / • / •
Minimum and maximum	• / •	• / •	•	•	•	•	•
Events and alarms with timestamps	•	•	•	•	•	•	•
Timestamp resolution (seconds)	0.001	0.001	0.001	0.001	0.001	0.001	0.001
Time sync: Network / GPS / IIRIG-B / DCF77-B / PTP	• / • / • / • / •	• / • / • / • / •	• / • / • / - / -	• / • / • / - / -	• / • / • / - / -	• / • / • / - / -	• / • / • / - / -
<b>Setpoints, alarms and control</b>							
Log alarm conditions / call out on alarm	• / •	• / •	• / •	• / •	• / •	• / •	• / •
Trigger data logging / waveform capture	• / •	• / •	• / •	• / -	• / -	• / •	• / •
Trigger relay or digital output	•	•	•	•	•	•	•
<b>Special features</b>							
Custom programming	•	•	•	•	•	•	•
Downloadable firmware	•	•	•	•	•	•	•
<b>Communications</b>							
<b>Ports:</b>							
Ethernet: Copper / Fiber	2 / 1	2 / 1	• / •	• / •	• / •	2 / 1	2 / 1
Ethernet-to-serial gateway	•	•	•	•	•	•	•
Telephone modem	-	-	•	•	•	-	-
Modem-to-serial gateway	-	-	•	•	•	-	-
Verizon 4G LTE Cellular Modem[5]	-	-	•	•	•	-	-
Infrared port	•	•	•	• / •	• / •	•	-
RS485/RS232	• / -	• / -	• / •	• / •	• / •	• / -	• / -
Misc: Web server / Email / SNMP / XML	• / • / • / •	• / • / • / •	• / • / - / •	• / • / - / •	• / • / - / •	• / • / • / •	• / • / • / •
Protocols: Modbus / DNP / MV-90 / DLMS	• / • / • / -	• / • / • / -	• / • / • / -	• / • / • / -	• / • / • / -	• / • / • / -	• / • / • / -
Protocols: IEC61850 / Jbus / M-Bus / LON / BACnet	• / - / - / - / -	• / - / - / - / -	• / - / - / - / -	• / - / - / - / -	• / - / - / - / -	• / - / - / - / -	• / - / - / - / -

NOTE:

1. The ION8650 is two times more accurate than the 0.2 IEC/ANSI accuracy classes according to the same conditions used to specify the 0.2 accuracy class.
2. ION8800, ION8650, ION8600, PM8000 also offer Modbus Master capabilities.

[1] Specifications represent maximum capabilities with all options installed. Some options are not available concurrently. This is not a complete feature list, please refer to detailed product specifications.

[2] Advanced Variant is Class A and Standard Variant is Class S.

[3] Flicker not available on Essential Variant.

[4] Disturbance Direction Detection not available on Essential Variant.

[5] Only available on socket meter versions.



### ION9000 Series Advanced Power Quality Meters

Web enabled PowerLogic™ ION9000 series meters are used to monitor electric distribution networks, service entrances and substations. It enables businesses to manage complex energy supply contracts that include power quality guarantees. Low-range current accuracy makes it ideal for independent power producers and cogeneration applications that require the accurate bi-directional measurement of energy. It is well suited to load curtailment, equipment monitoring and control and energy pulsing and totalization applications. Integrate it with Power Management Software applications. The ION9000T captures extremely fast voltage events that are missed by most other power meters, enabling advanced diagnostics and high-resolution event associations for fast, conclusive diagnosis and resolution to transient voltages.

#### ION9000 Power and Energy Meter Features

PQ compliance reporting and basic PQ analysis:

- Monitors and logs parameters in support of international PQ standards
  - IEC 61000-4-30 Class A (test methods as per IEC 62586-2)
- High resolution waveform capture: triggered manually or by alarm. Captured waveforms available directly from the meter via FTP in a COMTRADE format, and viewable in the meter's web interface.
- Generates PQ compliance reports accessible via onboard web pages:
- Harmonic analysis:
  - THD and TDD per phase, min/max, custom alarming
  - Individual harmonic magnitudes and angles on voltage and current, up to the 63rd harmonic
- Disturbance detection and capture: sag/swell on any current and voltage channel, alarm on disturbance event, waveform capture with per-event information
- Patented disturbance direction detection: provides indication of the captured disturbance occurring upstream or downstream of the meter; timestamped results provided in the event log, with degree of certainty of disturbance direction
- Transient capture of events 20 microseconds or longer in duration on any voltage channel with waveform capture and per-event information
- PowerLogic ION9000T provides high-speed transient capture (HSTC) of voltage events 100 nanoseconds or longer in duration and up to 10,000 V in magnitude on voltage channels and with an alarm on the event, the ION9000T provides high-speed and disturbance waveform captures, as well as per-event statistics on each transient.

Metering precision:

- IEC 61557-12 PMD/SD/K70/0.2 and PMD/SS/K70/0.2 3000m (performance measuring and monitoring devices (PMD))
- Class 0.1S accuracy IEC 62053-22, ANSI C12.20 Class 0.1 (active energy)
- Industry leading Class 0.5S accuracy for reactive energy (IEC 62053-24)
- Cycle-by-cycle RMS measurements updated every cycle
- Full 'multi-utility' WAGES metering support
- Net metering
- Anti-tamper protection seals and hardware metrology lock

Cybersecurity:

- Security events logging with Syslog protocol support
- HTTPS secure protocol
- Ability to enable or disable any communication port and any protocol per port
- Anti-tamper protection seals and hardware metrology lock
- User accounts with strong passwords
- Used with Schneider Electric's advanced software tools, provides detailed PQ reporting across entire network:
- EN 50160 compliance report
- IEEE 519 harmonic compliance report
- IEC 61000-4-30 report
- Power quality compliance summary
- Energy reports for consumption analysis and cost management
- WAGES dashboards and reports
- Display of waveforms and PQ data from all connected meters
- Onboard web-based waveform viewer
- EcoStruxure™ Power Events Analysis, including alarm management, sequency of events, and root cause analysis

Data and event logging:

- Onboard data and event logging
- 2 GB of standard non-volatile memory
- No data gaps due to network outages or server downtime
- Min/max log for standard values
- 100 user-definable data logs, recording up to 16 parameters on a cycle-by-cycle or other user definable interval
- Continuous logging or snapshot, triggered by setpoint and stopped after defined duration

- Trend energy, demand and other measured parameters
- Forecasting via web pages: average, minimum and maximum for the next four hours and next four days
- Advanced time-of-use capability
- Security/event log: alarm conditions, metering configuration changes, power outages, firmware download, and user login/logout all timestamped to ±1 millisecond

Alarming and control:

- 50+ definable alarms to log critical event data, trigger waveform recording, or perform control function
- Trigger on any condition, with 1/2-cycle and 1-second response time
- Combine alarms using Boolean logic enabling customization of alarms
- Alarm notification via email
- In conjunction with Schneider Electric's EcoStruxure software, alarms, software alarms, and alarm frequency are categorized and trended enabling sequence of events and root cause analyses

**Table 4.1: Typical PowerLogic ION9000 Power and Energy Meter Ordering Configurations**

Description <sup>[6]</sup>	Catalog Number
ION9000 meter, DIN mount, no display, HW kit	METSEION92030 METSEION92030-US <sup>[7]</sup>
ION9000 meter, DIN mount, 192 mm display, B2B adapter, HW kit	METSEION92040 METSEION92040-US <sup>[7]</sup>
ION9000 meter, LVDC control power, DIN mount, no display, HW kit	METSEION92130 METSEION92130-US <sup>[7]</sup>
ION9000 meter, LVDC control power, DIN mount, 192mm display, B2B adapter, HW kit	METSEION92140 METSEION92140-US <sup>[7]</sup>
ION9000 meter, low voltage current sensor inputs, DIN mount, no display, HW kit	METSEION93030
ION9000 Meter, low voltage current sensor inputs, DIN mount, 192mm display, B2B adapter, HW kit	METSEION93040
ION9000 meter, low voltage current sensor inputs, LVDC control power, DIN mount, no display, HW kit	METSEION93130
ION9000 meter, low voltage current sensor inputs, LVDC control power, DIN mount, 192mm display, B2B adapter, HW kit	METSEION93140
ION9000 meter, high-speed transient capture, DIN mount, no display, HW kit	METSEION95030 METSEION95030-US <sup>[7]</sup>
ION9000 meter, high-speed transient capture, DIN mount, 192 mm display, B2B adapter, HW kit	METSEION95040 METSEION95040-US <sup>[7]</sup>
Remote display, color LCD, 96 x 96 mm	METSEPM89RD96
Remote display, color touchscreen, 192 x 192 mm	METSERD192
I/O module, 2 relay outputs, 6 digital inputs	METSEPM89M2600
I/O module, 2 analog outputs, 4 analog inputs	METSEPM89M0024
ION9000 meter hardware kit – plugs, terminal guards, spare grounding screw, DIN clips	METSE9HWK
ION9000 meter hardware kit for low voltage current sensor models	METSE9HWKLVCS
RD192 remote display hardware kit	METSERD192HWK
ION9000 B2B adapter	METSE9B2BMA
ION9000 USB cover hardware kit	METSE9USBK
ION9000 Current Input hardware kit – terminal screws, CT covers	METSE9CTHWK
Battery replacement kit – ION7400/ION9000/PM8000	METSEPMBATK
ION7x50 Mounting Adapter Kit	METSE7X4MAK

[6] NOTE: Contact your local Schneider Electric representative for complete ordering information.

[7] Catalog numbers ending in "-US" are Buy American Act (BAA) compliant.



### ION8650 Power and Energy Meters

The web-enabled PowerLogic™ ION8650 is used to monitor electric distribution networks, service entrances and substations. It enables businesses to manage complex energy supply contracts that include power quality guarantees. Low-range current accuracy makes it ideal for independent power producers and cogeneration applications that require the accurate bi-directional measurement of energy. It is well suited to load curtailment, equipment monitoring and control and energy pulsing and totalization applications. Integrate it with Power Management Software applications to get the most out of the meter's capabilities and data produced.

#### Applications

- Revenue metering
- Cogeneration and IPP monitoring
- Power Quality Compliance monitoring
- Power quality analysis
- Demand and power factor control
- Load curtailment
- Equipment monitoring and control
- Energy pulsing and totalization
- Instrument transformer correction
- Outage Notification

#### ION8650 Power and Energy Meter Features

##### Feature set C includes:

- 9S, 35S, 36S socket and switchboard cases
- True RMS 3-phase voltage, current, power and meets stringent ANSI revenue metering standards including ANSI C12.20 0.2 and Class 2, 10, & 20
- Power quality: sag/swell, individual, even, odd, total harmonics to the 31st and symmetrical components
- 32 Mb log/event memory, min/max for any parameter, historical logs up to 80 channels, timestamp resolution to 0.001 seconds and GPS time synchronization
- Transformer/line loss compensation and Instrument transformer correction
- Communications: Ethernet, Serial, Modem, Internet and Ethernet to serial gateway and ION, DNP 3.0, Modbus RTU, Modbus TCP, MV-90 protocols, IEC 61850
- C model limited to IR + 2 other ports at one time. Ports can be enabled/disabled by user
- Dial-out capability when memory is near full
- Multi-user, multi-level security with control and customized access to sensitive data for up to 50 users
- Data push capability through SMTP (email)
- 65 setpoints — math, logic, trig, log, linearization formulas
- Password protection and anti-tamper seal protection
- Built-in I/O: 4 KYZ digital outs and 3 form A digital ins, 4 KYZ digital outs and 1 form A digital out and 1 form A digital in, an optional external I/O expander provides additional I/O
- Optional Outage Notification Card for JSON outage notification message over ethernet

##### Feature set B adds the following to feature set C:

- Harmonics—individual, total even, total odd up to the 63rd
- 64 Mb standard memory
- Historical logs up to 320 channels
- Modbus RTU Master on serial ports
- Cycle setpoint minimum response time

##### Feature set A adds the following to feature sets C and B:

- Waveform capture up to 1024 samples/cycle, PQ compliance monitoring, flicker to EN50160 Ed2, IEC 61000-4-7/4-15 (also configurable to IEC61000-4-15, IEC61000-4-30, SEMI) CBEMA/ITIC
- Transient detection to 17µs at 60 Hz
- Harmonics: magnitude, phase and inter-harmonics to the 50th
- 128 Mb standard memory
- Max 96 cycles of waveform logs and 800 channels of historical logs

Table 4.2: Typical PowerLogic ION8650 Power and Energy Meter Ordering Configurations

Description	Catalog Number
ION8650, feature set A, 9S socket base, 5 A nominal current inputs, 10 MB memory, 127–177 Vac, 60 Hz, communications card with: 10BaseT, RS-232/485, RS-485, Optical port, 4 Digital Outputs, 3 Digital Inputs	S8650A0C0E6E1B0A
ION 8650; feature set A, 9S socket base, 5 A nominal current inputs, 128 MB memory, 120–277 VAC, 60 Hz, comms card with: 10/100BaseT, RS-232/485 port, RS-485, 56k internal modem (RJ11), Infrared Optical Port; No I/O, Password Protected, no security lock	S8650A0C0E6C7A0A
ION8650, feature set C, 9S socket base, 5 A nominal current inputs, 2 MB memory, 120–277 Vac, 60 Hz, communications card with: RS-232/ 485, RS-485, Optical port, 4 Digital Outputs, 3 Digital Inputs	S8650C0C0E6A0B0A
ION 8650; feature set C, 9S socket base, 5 A nominal current inputs, 32 MB memory, 120–277 VAC, 60 Hz, comms card with 10/100BaseT, RS-232/485 port, RS-485 port, Infrared Optical Port, No I/O, Password Protected, no security lock	S8650C0C0H6E1A0A

Table 4.3: ION8650 Order Codes/Descriptions

Brand	Model	Feature Set	Form Factor	Current Inputs	Voltage Inputs	Power Supply	System Freq	Comm	I/O	Security	Special Order	AA Code
S	8650				C	0					A	-AAxxx
ION8650		Order Code	Description									
Brand		S	Schneider branded									
Model		8650	ION8650 advanced revenue meter with Class 0.1 accuracy + IRIG-B									
Feature Set		A	128MB Memory Class A power quality analysis, waveforms and transient capture with 1024 samples/cycle.									
		B	64MB memory, energy meter Class S EN50160 power quality monitoring.									
		C	32MB memory, basic tariff/energy metering (4 data recorders, 64 channels).									
Form Factor		0	Form 9/29/36S Base - 57-277 VLN (autoranging) 3-Element, 4-Wire / 2 1/2-Element, 4-Wire									
		1	Form 35S Base - 120-480 VLL (autoranging) 2-Element, 3-Wire									
		4	Form 9/29/35/36S FT21 Switchboard (meter + case) with break out panel									
		7	Form 9/29/35/36S FT21 Switchboard (meter + case) with break out cable									
Current Inputs		C	1, 2 or 5 Amp nominal, 20 Amp full scale current input (24 Amp fault capture, start at 0.001A)									
Voltage Inputs		0	Standard (see Form Factor above)									
Power Supply		E	Form 9S, 36S (socket) and Form 9,36 (FT21 switchboard): 120-277 Vac. Form 35S (socket) and Form 35 (FT21 switchboard): 120-480 Vac. Powered from the meter's voltage connections.									
		H	Auxiliary Power Pigtail: 65-120 Vac, 80-160 Vdc (power from external source), North American Plug Style									
		J	Auxiliary Power Pigtail: 160-277 Vac, 200-350 Vdc (power from external source), North American Plug Style									
System Frequency		5	50 Hz									
		6	60 Hz									
Communications <sup>[8]</sup>		C7	Ethernet (10/100BASE-T), 56k universal internal modem (RJ11), RS-232/485 port, RS-485 port, Infrared Optical port									
		E1	Ethernet (10/100BASE-T), RS-232/485 port, RS-485 port, Infrared Optical port									
		F1	Ethernet (100BASE-FX multi-mode) with male ST connectors, RS-232/485 port, RS-485 port, Infrared Optical port (available on socket meters only, Forms 0 & 1 above. I/O card not available if this option is ordered.)									
		S1	Ethernet (10/100-BASE-T), Verizon 4G cell modem - SIM CARD OPTION, RS 232/485 port, RS 485 port, Infrared optical port									
Input/Output Option		A	None									
		B	4 Form C Digital Outputs, 3 Digital Inputs (not available with Communications option F1)									
		C	4 Form C Digital Outputs, 1 Form A Digital Output, 1 Digital Input									
		D	Ride-Through Module for JSON outage notification message over Ethernet. (only available with comms option E1, C7 & S1)									
Security		0	Password protected, no security lock									
		1	Password protected with security lock enabled									
		7	Password protected, no security lock (available in US only)									
		8	Password protected with security lock enabled (available in US only)									
Special Order Options		A	None									

4

POWER MONITORING AND CONTROL

[8] In addition to Infrared Optical port Feature Set C can use any two ports (configurable).



PowerLogic ION7400

### PowerLogic™ ION7400 Utility Feeder Meter

The PowerLogic™ ION7400 utility feeder meter is a highly accurate, extremely reliable power and energy meter with unmatched flexibility and usability. The meter combines accurate 3-phase energy and power measurements with data logging, power quality analysis, alarming and I/O capabilities not typically available in such a compact meter.

The panel or DIN mounted ION7400 meter is flexible enough to fit into a utility's existing billing or SCADA system, providing industry leading cost management (Class 0.2) and network management (Class S and A PQ data). It is compliant with stringent international standards that guarantee their metering accuracy and power quality measurements. Ideal for installations that are responsible for maintaining the operation and profitability of a facility.

#### Applications and benefits

- Maximize profits by providing the highest output possible with the least amount of risk to availability.
- Optimize availability and reliability of electrical systems and equipment.
- Monitor power quality (PQ) for compliance and to prevent problems.
- Meters fully supported by EcoStruxure Power Monitoring Expert and PowerSCADA Operation Software.

#### Main Characteristics

- Precision metering
- PQ compliance reporting and basic PQ analysis
- Used with EcoStruxure™ Power Monitoring Expert software, provides detailed PQ reporting across entire network
- Onboard data and event logging
- Alarming and control
- Excellent quality: ISO 9001 and ISO 14000 certified manufacturing.

Table 4.4: PowerLogic ION7400 Meters

Description	Catalog Number		
	Essential	Standard	Advanced
ION7400 Panel mount meter (integrated display with optical port and 2 energy pulse LEDs)	METSEION7400E	METSEION7400	METSEION7400A
ION7400 Panel mount meter (integrated display with optical port and 2 energy pulse LEDs), 20-60 Vdc control power	METSEION7410E	METSEION7410	METSEION7410A
DIN rail mount - utility meter base	METSEION7403E	METSEION7403	METSEION7403A
DIN rail mount - utility meter base with remote display	METSEION7404E	METSEION7404	METSEION7404A
DIN rail mount - utility meter base, 20-60 Vdc control power	METSEION7413E	METSEION7413	METSEION7413A

Table 4.5: PowerLogic ION7400 Accessories

Description	Catalog Number
Remote display, 3 metre cable, mounting hardware for 30 mm hole (nut and centering pin), mounting hardware for DIN96 cutout (92 x 92 mm) adapter plate	METSEPM89RD96
Digital I/O module (6 digital inputs and 2 relay outputs)	METSEPM89M2600
Analog I/O module (4 analog inputs and 2 analog outputs)	METSEPM89M0024
Display Cable, 10 m	METSECAB10
4-Wire RS 485 option module	METSEPMRS4854W
Fiber-Ethernet option module	METSEPMFIBER
Sealing kit	METSEPM8000SK



PowerLogic ION7400 showing active alarms.



PowerLogic ION7400 with harmonics display.



PowerLogic ION7400 with phasor display.

Table 4.6: PowerLogic ION7400 Features

Description	ION7400 Essential	ION7400 Standard	ION7400 Advanced
<b>General</b>			
Use on LV and MV systems	■	■	■
Current accuracy (5A Nominal)	0.1 % reading	0.1 % reading	0.1 % reading
Voltage accuracy (90-690 V AC L-L, 50, 60, 400 Hz)	0.1 % reading	0.1 % reading	0.1 % reading
Active energy accuracy	0.2 Class	0.2 Class	0.2 Class
Reactive energy accuracy	2%	2%	2%
Number of samples/cycle or sample frequency	256 <sup>[9]</sup>	256	512
ION programmability	■	■	■
<b>Instantaneous rms values</b>			
Current, voltage, frequency	■	■	■
Active, reactive, apparent power	Total and per phase	■	■
Power factor	Total and per phase	■	■
Current measurement range (autoranging)	0.05 - 10 A	0.05 - 10 A	0.05 - 10 A
<b>Energy values</b>			
Active, reactive, apparent energy	■	■	■
Settable accumulation modes	■	■	■
<b>Demand values</b>			
Current	Present and max. values	■	■
Active, reactive, apparent power	Present and max. values	■	■
Predicted active, reactive, apparent power	■	■	■
Synchronisation of the measurement window	■	■	■
Setting of calculation mode	Block, sliding	■	■
<b>Power quality measurements</b>			
Harmonic distortion	Current and voltage	■	■
Individual harmonics	Via front panel and web page	31	63
	Via EcoStruxure™ software	—	127
Waveform capture	■ <sup>[9]</sup>	■	■
Detection of voltage swells and sags	■	■	■
Flicker	—	■	■
Fast acquisition	1/2 cycle data	■	■
IEC61000-4-30 Class A/S	—	S	A
EN 50160 compliance checking	—	■	■
IEEE 519 compliance checking	—	■	■
Disturbance Direction Detection	—	■	■
Rapid Voltage Change	—	■	■
Customizable data outputs (using logic and math functions)	■	■	■
<b>Data recording</b>			
Min/max of instantaneous values	■	■	■
Data logs	■	■	■
Event logs	■	■	■
Trending/forecasting	—	■	■
SER (Sequence of event recording)	■	■	■
Time stamping	■	■	■
GPS synchronization (+/- 1 ms)	■	■	■
Data Recorder	10	50	64
Memory Channels	160	800	1024
Storage (in Mbytes)	64	512	512
<b>Display and I/O</b>			
Front panel display 89 mm TFT	■	■	■
Wiring self-test	■	■	■
Pulse output	1	1	1
Digital or analog inputs (max)	27 digital 16 analog	27 digital 16 analog	27 digital 16 analog
Digital or analogue outputs (max, including pulse output)	1 digital 8 relay 8 analog	1 digital 8 relay 8 analog	1 digital 8 relay 8 analog
<b>Communication</b>			
2-Wire RS 485 port	1	1	1
10/100BASE-TX	2	2	2
Serial port (Modbus, ION, DNP3, DLMS/COSEM)	■	■	■
Ethernet port (Modbus/TCP, ION TCP, DNP3 TCP, IEC 61850, DLMS/COSEM <sup>[10]</sup> )	■	■	■
USB port (mini type B)	■	■	■
ANSI C12.19 Optical port	■	■	■
Option module with 4-Wire RS-485 port	■	■	■
Option module with Fiber-Ethernet port	■	■	■
<b>Standards</b>			
ANSI C12.20, CLC/TTR50579, EN 50160, IEC 61000-4-7, IEC 6100-4-15, IEC 61000-4-30, IEC 61010-1, IEC 61326, IEC 61557-12, IEC 61850, IEC 62052-11, IEC 62053-22, IEC 62053-23, IEC 62586, and IEEE 519			

[9] Waveform capture is limited to 128 Samples/cycle recording.

[10] All the communication ports may be used simultaneously.



**Address power issues before they cause problems**

- Monitor harmonics to mitigate excessive heating and premature failure of transformers
- Use trending and alarming to detect fluctuations in current pull of critical equipment to prevent motor failure
- Utilize millisecond time stamping to analyze sequence of events
- Identify root cause by analyzing electrical faults with patented disturbance direction detection
- Identify power quality issues per EN 50160, including frequency inconsistency, voltage fluctuations and unbalance, and harmonic contribution
- Allocate costs for water, air, gas, electricity, and steam (WAGES) across departments, phases of industrial process, or cost centers
- Utilize time-of-use calendar to capture electrical consumption for specific times, including on/off peak and holidays

**PowerLogic PM8000 Advanced Power Quality Meters**

These compact meters help ensure the reliability and efficiency of your facility by making the management of power quality, availability, and reliability easy. Measure, understand, and act on insightful power and energy data gathered from your entire system.

**The best choice for power management**

PM8000 meters combine accurate 3-phase energy and power measurements with data logging, power quality analysis, alarming and I/O capabilities not typically available in such compact meters. Four-metered current inputs allow direct measurement of 3-phase currents and neutral current for enhanced view of harmonics. Dual Ethernet ports support daisy-chaining, removing need for an Ethernet switch inside power equipment, while redundant ring topology provides enhanced availability. Modular, field installable I/O provides expandable scalability. Patented ION technology combines convenient, pre-configured functionality with the ability to customize the meter configuration to meet unique requirements. This embedded capability can save the expense and complexity of additional equipment, both today and tomorrow. Plus, simple installation and networking make energy information quickly accessible, while integration with EcoStruxure™ software and your energy management system make it immediately actionable.

**Table 4.7: PM8000 Power and Energy Meter Catalog Numbers—Meters**

Description	Catalog Number
96 x 96 panel mount meter, AC/DC power	METSEPM8140
	METSEPM8240
	METSEPM8340
96 x 96 panel mount meter, LV DC power	METSEPM8110
	METSEPM8210
	METSEPM8310
DIN rail mount meter, AC/DC power	METSEPM8143
	METSEPM8243
	METSEPM8343
DIN rail mount meter, LV DC power	METSEPM8113
	METSEPM8213
	METSEPM8313
DIN rail mount meter with remote display, AC/DC power	METSEPM8144
	METSEPM8244
	METSEPM8344
DIN rail mount meter with remote display, LV DC power	METSEPM8114
	METSEPM8214
	METSEPM8314

**Table 4.8: PM8000 Power and Energy Meter Catalog Numbers—Accessories**

Description	Catalog Number
Remote Display, Color LCD, 96 x 96	METSEPM89RD96
I/O module, 2 relay outputs, 6 digital inputs	METSEPM89M2600
I/O module, 2 analog outputs, 4 analog inputs	METSEPM89M0024
Display Cable, 10 meters	METSEPCAB10
Display Cable, 3 meters	METSEPCAB3
Display Cable, 1 meters	METSEPCAB1
Sealing kit	METSEPM8000SK
Mounting adapter kit (ANSI 4")	METSEPM8AK
Replacement hardware kit, PM8000 meter	METSEPM8HWK
Replacement hardware kit, PM8000 remote display	METSEPM8RDHWK
4-Wire RS 485 option module	METSEPMRS4854W
Fiber-Ethernet option module	METSEPMFIBER
Sealing kit	METSEPM8000SK

Table 4.9: PM8000 Series Features

		PM81xx Essential	PM82xx Standard	PM83xx Advanced
<b>General</b>				
Use on LV, MV, and HV systems		■	■	■
Current accuracy (5A Nominal)		0.1 % reading	0.1 % reading	0.1 % reading
Voltage accuracy		0.1 % reading	0.1 % reading	0.1 % reading
Active energy accuracy		0.2 Class	0.2 Class	0.2 Class
Number of samples/cycle or sample frequency		256 <sup>[11]</sup>	256	512
ION programmability		■	■	■
<b>Instantaneous rms values</b>				
Current, voltage, frequency		■	■	■
Active, reactive, apparent power	Total and per phase	■	■	■
Power factor	Total and per phase	■	■	■
Current measurement range (autoranging)		0.05–10 A	0.05–10 A	0.05–10 A
<b>Energy values</b>				
Active, reactive, apparent energy		■	■	■
Settable accumulation modes		■	■	■
<b>Demand values</b>				
Current	Present and max. values	■	■	■
Active, reactive, apparent power	Present and max. values	■	■	■
Predicted active, reactive, apparent power		■	■	■
Synchronization of the measurement window		■	■	■
Setting of calculation mode	Block, sliding	■	■	■
<b>Power quality measurements</b>				
Harmonic distortion	Current and voltage	■	■	■
Individual harmonics	Via front panel and web page	31	63	63
	Via EcoStruxure software	—	127	127
Waveform capture		■ <sup>[11]</sup>	■	■
Detection of voltage swells and sags		■	■	■
Fast acquisition	1/2 cycle data	■	■	■
IEC 61000–4–30 Class A/S		—	S	A
EN 50160 Interharmonic		—	—	■
EN 50160 compliance checking		—	■	■
IEEE 519 compliance checking		—	■	■
Disturbance Direction Detection		—	■	■
Rapid Voltage Change		—	■	■
Customizable data outputs (using logic and math functions)		■	■	■
<b>Data recording</b>				
Min/max of instantaneous values		■	■	■
Event logs		■	■	■
Trending/forecasting		—	■	■
SER (Sequence of event recording)		■	■	■
Time stamping		■	■	■
GPS synchronization (+/- 1 ms)		■	■	■
Data Recorder		10	50	64
Memory Channels		160	800	1024
Storage (in Mbytes)		64	512	512
<b>Display and I/O</b>				
Front panel display		■	■	■
Wiring self-test		■	■	■
Pulse output		1	1	1
Digital or analog inputs (max)		27 digital 16 analog	27 digital 16 analog	27 digital 16 analog
Digital or analog outputs (max, including pulse output)		1 digital 8 relay 8 analog	1 digital 8 relay 8 analog	1 digital 8 relay 8 analog
<b>Communication</b>				
2-Wire RS-485 port		1	1	1
Ethernet ports		2	2	2
Serial port (Modbus, ION, DNP3)		■	■	■
Ethernet port (Modbus/TCP, ION TCP, DNP3 TCP, DHCP, DNS, IPv4, IPv6, IEC 61850)		■	■	■
Ethernet gateway		■	■	■
Alarm notification via email		■	■	■
HTTP/HTTps web server with waveform viewer		■	■	■
SNMP with custom MIB and traps for alarms		■	■	■
SMTP email		■	■	■
PTP and NTP time synchronization		■	■	■
FTP File transfer		■	■	■
Option module with 4-Wire RS-485 port		■	■	■
Option module with Fiber-Ethernet port		■	■	■

4

POWER MONITORING AND CONTROL

[11] Waveform capture is limited to 128 Samples/cycle recording.



PM5000 Series Power Meter

### Series PM5000 Power Meters

The PowerLogic™ PM5000 series power meters are the new benchmark in affordable, precision metering. It is the ideal fit for high-end cost management applications, providing measurement capabilities needed to allocate energy usage, perform tenant metering and sub-billing, pin-point energy savings, optimize equipment efficiency and utilization, and perform a high level assessment of the power quality in electrical networks.

All meters provide Modbus serial communications. PM5500 level meters are also capable of simultaneous ModBus TCP and BTL-certified BACnet IP communications over Ethernet.

- Panel instrumentation (OEMs)
- Sub-billing and cost allocation
- Remote monitoring of an electrical installation
- Harmonic monitoring (THD)

Table 4.10: Series PM5000 Power Meters

Description	Catalog No.
Power Meter, Class 0.5 Serial Port	METSEPM5110
Meter, Class 0.5 Alarms TOU Serial Port	METSEPM5330
Power Meter, Class 0.5 Alarms TOU Ethernet Port	METSEPM5340
Power Meter Class 0.2 Serial Port and Dual Ethernet	METSEPM5560
Power Meter without Display Class 0.2 Serial Port and Dual Ethernet	METSEPM5563
Power Meter Class 0.2 Serial Port and Dual Ethernet, LVDC Control Power	METSEPM5580
Power Meter Class 0.2 Serial Port and Dual Ethernet, Waveform Capture, Sag/Swell	METSEPM5650
Remote Display for METSEPM5563	METSEPM5RD
Power Meter with Remote Display Class 0.2 Serial Port and Dual Ethernet	METSEPM5563RD <sup>[12]</sup>

### Series PM2000 Power Meters

The PM2000 series meter is a next-generation energy and power meter that offers all the measurement capabilities required to monitor an electrical installation in a single 96 x 96 mm unit. The PM2000 series offers simplicity and reliability for basic energy cost and network management applications at a value price. PM2000 meters are available in LED and LCD display variants:

- LED display type (PM2100 series): Intuitive navigation with self-guided, three buttons, bright red color LEDs of 14.2 mm height. Two columns of LEDs indicate the parameter name chosen for display.
- LCD display type (PM2200 series): Monochrome graphical LCD of 128 x 128 resolution lets users read all three phase values simultaneously. The bright display enables easy reading even in extreme lighting conditions and viewing angles with intuitive menus, multi-language text, icons and graphics.

PM2130 and PM2230 meter models have provisions to attach one input/output expansion module. Choose from: two digital inputs, two digital outputs; two analog inputs, two analog outputs; or two digital inputs, two relay outputs.



PM2100 Series LED Display Meter



PM2200 Series LCD Display Meter

Table 4.11: PM2000 Series Power Meters and Options

Description	Catalog Number
<b>Meters</b>	
PM2110, THD, LED display, Energy pulse output, Class 1	METSEPM2110
PM2120, 15th Harmonic, LED display, Modbus RS485, Class 1	METSEPM2120
PM2130, 31st Harmonic, LED display, Modbus RS485, Class 0.5S	METSEPM2130
PM2110, THD, LCD display, Energy pulse, Class 1	METSEPM2210
PM2220, 15th Harmonic, LCD display, Modbus RS485, Class 1	METSEPM2220
PM2230, 31st Harmonic, LCD display, Modbus RS485, Class 0.5S	METSEPM2230
<b>Optional Input/Output Modules</b>	
PM2X30 I/O Module - 2 Digital In, 2 Digital Out	METSEPM2KDGTLIO22
PM2X30 I/O Module - 2 Analog In, 2 Analog Out	METSEPM2KANLGIO22
PM2X30 I/O Module - 2 Digital In, 2 Relay Out	METSEPM2K2DI2RO

[12] METSEPM5563RD includes both METSEPM5563 and METSEPM5RD.



EM3500 Series Energy and Power Meter

### PowerLogic™ EM3500 Power and Energy Meters

The EM3500 series Energy and Power Meter combines exceptional performance and easy installation to deliver a cost-effective solution for power monitoring applications. The EM3500 series can be installed on standard DIN rail or surface mounted, and has bi-directional monitoring designed expressly for renewable energy applications.

- Pulse output and phase alarms
- Data logging capability in some models
- Modbus and BACnet output options

**Table 4.12: Series EM3500 Energy and Power Meters**

Description	Catalog Number
Power Meter, DIN-rail, Pulse Output Only, for LVCTs	METSEEM3502
Power Meter, DIN-rail Pulse Output Only, for METSECTR Rope CTs	METSEEM3502A
Power Meter, DIN-rail Modbus Output for LVCTs	METSEEM3550
Power Meter, DIN-rail, Modbus Output, for METSECTR Rope CTs	METSEEM3550A
Power Meter, DIN-rail Modbus Output, Bi-Directional, Logging for LVCTs	METSEEM3555
Power Meter, DIN-rail Modbus Output, Bi-Directional, Logging for METSECTR Rope CTs	METSEEM3555A
Power Meter, DIN-rail, BACnet Output, Logging for LVCTs	METSEEM3560
Power Meter, DIN-rail, BACnet Output, Logging for METSECTR Rope CTs	METSEEM3560A
Power Meter, DIN-rail, BACnet Output, for LVCTs	METSEEM3561
Power Meter, DIN-rail, BACnet Output, for METSECTR Rope CTs	METSEEM3561A

### METSECTR Series Rope-Style Current Transformers

The METSECTR series works with the EM3500A, EM4236, and iEM35xx series power and energy meters. These meters have a built in power supply and integrator, so CT connection is fast and simple. The coil opens at the connector junction for fast and easy installation onto an existing cable or bus-bar. The flexible core makes it easy to fit in tight enclosure.

- Agency Approvals cURus, ANSI/IEEE 57.13, CE, RoHS
- Accuracy ±1% from 50 A to 5000 A
- Insulation up to 600 Vac

**Table 4.13: METSECTR Series Rope-Style Current Transformers**

Description	Catalog Number
Rogowski CT, 300 mm (12"), 600 Vac, 5 kA, U018 equivalent	METSECTR30500
Rogowski CT, 460 mm (18"), 600 Vac, 5 kA, U018 equivalent	METSECTR46500
Rogowski CT, 600 mm (24"), 600 Vac, 5 kA, U018 equivalent	METSECTR60500
Rogowski CT, 900 mm (35"), 600 Vac, 5 kA, U018 equivalent	METSECTR90500

### LVCT Series Current Transformers

LVCT current transducers provide a 0.333 V output for use with EM3500, EM4236, iEM34xx, and EM4900 series energy meters. Available in both solid and split core styles.

- Solid core accuracy ±0.5 of reading from 5% to 120% of rated current
- Split core accuracy 1% from 10% to 100% of rated current
- Leads 22 AWG, 600 Vac, UL 1015 bonded pair, 6 ft. (1.8 m) standard length

**Table 4.14: LVCT Series Current Transformers**

Description	Catalog Number
<b>Split core</b>	
Low-Voltage CT, Split Core, Size 0, 50 A:0.33 V	LVCT00050S
Low-Voltage CT, Split Core, Size 1, 100 A:0.33 V	LVCT00101S
Low-Voltage CT, Split Core, Size 2, 100 A:0.33 V	LVCT00102S
Low-Voltage CT, Split Core, Size 1, 200 A:0.33 V	LVCT00201S
Low-Voltage CT, Split Core, Size 2, 200 A:0.33 V	LVCT00202S
Low-Voltage CT, Split Core, Size 2, 300 A:0.33 V	LVCT00302S
Low-Voltage CT, Split Core, Size 3, 400 A:0.33 V	LVCT00403S
Low-Voltage CT, Split Core, Size 3, 600 A:0.33 V	LVCT00603S
Low-Voltage CT, Split Core, Size 3, 800 A:0.33 V	LVCT00803S
Low-Voltage CT, Split Core, Size 4, 800 A:0.33 V	LVCT00804S
Low-Voltage CT, Split Core, Size 4, 1000 A:0.33 V	LVCT01004S
Low-Voltage CT, Split Core, Size 4, 1200 A:0.33 V	LVCT01204S
Low-Voltage CT, Split Core, Size 4, 1600 A:0.33 V	LVCT01604S
Low-Voltage CT, Split Core, Size 4, 2000 A:0.33 V	LVCT02004S
Low-Voltage CT, Split Core, Size 4, 2400 A:0.33 V	LVCT02404S
<b>Solid core</b>	
Low-Voltage CT, Solid Core, Size 0, 50 A:0.33 V	LVCT20050S
Low-Voltage CT, Solid Core, Size 0, 100 A:0.33 V	LVCT20100S
Low-Voltage CT, Solid Core, Size 2, 200 A:0.33 V	LVCT20202S
Low-Voltage CT, Solid Core, Size 3, 400 A:0.33 V	LVCT20403S

New!

### PowerLogic™ EM3570 Power and Energy Meters

The PowerLogic™ EM3570 series energy meters with Ethernet are the new benchmark for affordable and precision metering applications.

Designed for use in both energy management systems and building management systems, the PowerLogic™ EM3570 series DIN rail meters provide the measurement capabilities needed to allocate energy usage, perform sub-billing, pin-point energy savings, optimize equipment efficiency and utilization, and perform a basic assessment of the power quality of the electrical network.

Engineered on the trusted PowerLogic platform, Ethernet-enabled EM3570 DIN rail meters are designed to install easily and integrate seamlessly with existing BACnet/IP and Modbus TCP/IP networks common in today's building and power management systems. With wide range CT compatibility, high reliability, IEC 61557-12 and UL2808 compliance, as well as ASHRAE 90.1 for power and energy logging capability, EM3570 meters support the energy efficiency designs of most buildings and are ideally suited for energy cost management applications.



EM3570 Series Meter with power supply module

#### Application:

- |                                                                                                                                                                                                                                                                                            |                                                                                                                                                                                                                                                                                                                                                                               |
|--------------------------------------------------------------------------------------------------------------------------------------------------------------------------------------------------------------------------------------------------------------------------------------------|-------------------------------------------------------------------------------------------------------------------------------------------------------------------------------------------------------------------------------------------------------------------------------------------------------------------------------------------------------------------------------|
| <p><b>Cost Management</b></p> <ul style="list-style-type: none"> <li>• Energy monitoring in building automation systems</li> <li>• Renewable energy</li> <li>• Energy management</li> <li>• Commercial sub-metering</li> <li>• Industrial monitoring</li> <li>• Cost allocation</li> </ul> | <p><b>Network Management</b></p> <ul style="list-style-type: none"> <li>• Track real-time power conditions</li> <li>• Monitor control functions</li> <li>• Provide basic power quality values</li> <li>• Extended data log feature support up to 3 years</li> <li>• Analyze equipment and network status</li> <li>• BACnet/IP and Ethernet TCP/IP protocol support</li> </ul> |
|--------------------------------------------------------------------------------------------------------------------------------------------------------------------------------------------------------------------------------------------------------------------------------------------|-------------------------------------------------------------------------------------------------------------------------------------------------------------------------------------------------------------------------------------------------------------------------------------------------------------------------------------------------------------------------------|

Table 4.15: EM3570 Series Features

Features	EM3570 Range			
	METSEEM3570	METSEEM3570A	METSEEM3570X	METSEEM3570AX
<b>Current Input</b>				
0.333V or 1.0V LVCT	•		•	
Rogowski coil		•		•
<b>Accuracy</b>				
Class	CL 0.5S	CL 0.5S	CL 0.5S	CL 0.5S
<b>Display</b>				
Backlit LCD, multilingual, 4 lines, 4 concurrent values	•	•	•	•
<b>Power and energy metering</b>				
3-ph voltage, current, power, demand, energy, frequency, power factor	•	•	•	•
Multi-tariff	4	4	4	4
<b>Input/Output and Relays</b>				
Digital inputs	2	2	2	2
Relay output	1	1	1	1
<b>Alarms and Control</b>				
Alarms	17	17	17	17
Set point response time, seconds	1	1	1	1
Single and multi-condition alarms	•	•	•	•
Memory for data logging	2 GB	2 GB	2 GB	2 GB
<b>Communications</b>				
Ethernet port with Modbus TCP protocol	•	•	•	•
BACnet/IP protocol	•	•	•	•
Onboard web server with web pages	•	•	•	•

Table 4.16: EM3570 Series Meters

Description	Catalog Number
DIN Ethernet power meter, LVCT input with external power supply module	METSEEM3570
DIN Ethernet power meter, Rogowski coil input with external power supply module	METSEEM3570A
DIN Ethernet power meter, LVCT input without external power supply module	METSEEM3570X
DIN Ethernet power meter, Rogowski coil input without external power supply module	METSEEM3570AX
24V DC power supply module for DIN Ethernet meter 600V AC input	METSEEM3570PS
NEMA enclosure accessory for DIN Ethernet meter METSEEM35x Schneider brand	METSEEM3570ENC



PM3000 Series Power Meter

### PowerLogic™ PM3000 Power and Energy Meters

PM3000 series power meters are a cost-attractive, feature-rich range of DIN rail-mounted power meters that offers all the measurement capabilities required to monitor an electrical installation. Ideal for power metering and network monitoring applications that seek to improve the availability and reliability of your electrical distribution system, the meters are also fully capable of supporting sub billing and cost allocation applications. Four different models are available. Choose from models that provide Display Only, Display + Pulse Output, Display + Modbus, and Display + Modbus + DI/DO + Logging. All models use 1A/5A CTs.

Table 4.17: PM3000 Features

Available Features	PM3200 Range			
	PM3200	PM3210	PM3250	PM3255
<b>Performance Standard</b>				
IEC61557-12 PMD/Sx/K55/0.5	*	*	*	*
<b>General</b>				
Use on LV and HV systems	*	*	*	*
Number of samples per cycle	32	32	32	32
CT input 1A/5A	*	*	*	*
VT input	*	*	*	*
Multi-tariff	4	4	4	4
Multi-lingual backlit display	*	*	*	*
<b>Instantaneous rms Values</b>				
Current, voltage Per phase and average	*	*	*	*
Active, reactive, apparent power Total and per phase	*	*	*	*
Power factor Total and per phase	*	*	*	*
<b>Energy Values</b>				
Active, reactive and apparent energy; import and export	*	*	*	*
<b>Demand Values</b>				
Current, power (active, reactive, apparent) demand; present	*	*	*	*
Current, power (active, reactive, apparent) demand; peak	*	*	*	*
<b>Power Quality Measurements</b>				
THD Current and voltage	*	*	*	*
<b>Data Recording</b>				
Min/max of the instantaneous values	*	*	*	*
Power demand logs				*
Energy consumption log (day, week, month)				*
Alarms with time stamping		5	5	15
Digital inputs/digital outputs		0/1		2/2
<b>Communication</b>				
RS-485 port			*	*
Modbus protocol			*	*

Table 4.18: PM3000 Series Power Meters

Description	Catalog Number
PM3200 3PH energy meter, DIN rail mount, 1A or 5A CT, Class 0.5S, no communications	METSEPM3200
PM3210 3PH energy meter, DIN rail mount, 1A or 5A CT, Class 0.5S, pulse out, THD, one (1) DO	METSEPM3210
PM3250 3PH energy meter, DIN rail mount, 1A or 5A CT, Class 0.5S, Modbus, THD	METSEPM3250
PM3255 3PH energy meter, DIN rail mount, 1A or 5A CT, Class 0.5S, Modbus, THD, two (2) DI, two (2) DO	METSEPM3255

### iEM3000 Energy Meters

The economical iEM3000 energy meters are ideal for helping facilities become more energy efficient. These feature-rich meters reduce installation and commissioning costs thanks to their efficient design and include native support for a variety of protocols, including Modbus, BACnet, LON, and M-Bus, for seamless integration into networks. Choose from models supporting a variety of current-sensing methods, including standard 1A/5A current transformers, 0.333 V low-voltage CTs, and METSECTR Rogowski coils. There are also direct connect models with internal current sensors that save installation time. The compact size is ideal for new and retrofit installations. Whether metering for energy awareness, billing, or advanced energy programs requiring full-featured, multi-tariff energy meters, there is an iEM3000 meter that fits the application.



iEM3000 Series Energy Meter

**NOTE:**

- For meter part number replace “i” in model name with “A9M”. (Example: iEM3150 = A9MEM3150)
- DIN rail housing size is 18mm x 5 width. (iEM33xx is 18mm x 7 width.)
- Digital input is selectable for Tariff control or WAGES
- Digital output is selectable for kWh pulse or kW alarm. (iEM3x10 is kWh pulse only.)

**Table 4.19: iEM3000 Features**

Function	Acti 9 iEM3000 Series Three-Phase Meters						
<b>Current Input / Accuracy</b>							
63A Direct / Class 1	iEM3100	iEM3110	iEM3135	iEM3150	iEM3155	iEM3165	iEM3175
1A or 5A CT / Class 0.5S	iEM3200	iEM3210	iEM3235	iEM3250	iEM3255	iEM3265	iEM3275
125A Direct / Class 1	iEM3300	iEM3310	iEM3335	iEM3350	iEM3355	iEM3365	iEM3375
0.333V or 1.0V LVCT / Class 0.5S					iEM3455	iEM3465	
Rogowski coil / Class 0.5S					iEM3555	iEM3565	
<b>Protocol</b>							
M-Bus			*				
Modbus				*	*		
BACnet						*	
LonWorks							*
<b>Measurement</b>							
MID compliant		*	*		*	*	*
4 quadrant energy			*		*	*	*
Demand					[13]	[13]	
Peak demand					[13]	[13]	
<b>Multi Tariff</b>							
Internal clock			4		4	4	4
External control			2		4	4	4
<b>Digital I/O</b>							
Number of inputs/outputs		-/1	1/1		1/1	1/1	1/1

**Measurement parameters**

- Total and partial kWh shows consumption behavior
- Four-quadrant metering differentiates energy consumption
- Target green technologies (delivered/received)
- Reduce utility penalties (active/reactive)
- Additional parameters (P, Q, S, 3xI, V, PF, F) to monitor network balance and overload behavior

**Smart Alarm**

- kWh overload alarm helps prevent utility demand charges

**Multiple Tariffs**

- Save up to four different time slots to manage multiple tariffs (peak/off-peak, workday/weekend)
- Control tariffs via digital inputs, internal clock, or communication

**Digital Inputs**

- Use the meter as a pulse counter for another meter (WAGES monitoring)
- Manage double-source applications (e.g., utility main plus on-site generator)
- Monitor circuit breaker status or cabinet door opening

**Digital Outputs**

- Use to trip a light or sound an alarm
- Configure as a pulse output

**Table 4.20: iEM3000 Series Energy Meters**

Description	Catalog Number
iEM3100 3PH energy meter, DIN rail mount, direct connect 63A, Class 1	A9MEM3100
iEM3110 3PH energy meter, DIN rail mount, direct connect 63A, Class 1, pulse out, MID, one (1) DO	A9MEM3110
iEM3135 3PH energy meter, DIN rail mount, direct connect 63A, Class 1, M-Bus, MID, 4-quadrant energy, one (1) DI, one (1) DO	A9MEM3135
iEM3150 3PH energy meter, DIN rail mount, direct connect 63A, Class 1, Modbus	A9MEM3150
iEM3155 3PH energy meter, DIN rail mount, direct connect 63A, Class 1, Modbus, MID, 4-quadrant energy, one (1) DI, one (1) DO	A9MEM3155
iEM3165 3PH energy meter, DIN rail mount, direct connect 63A, Class 1, BACnet, MID, 4-quadrant energy, one (1) DI, one (1) DO	A9MEM3165
iEM3175 3PH energy meter, DIN rail mount, direct connect 63A, Class 1, LON, MID, 4-quadrant energy, one (1) DI, one (1) DO	A9MEM3175
iEM3200 3PH energy meter, DIN rail mount, 1A or 5A CT, Class 0.5S	A9MEM3200
iEM3210 3PH energy meter, DIN rail mount, 1A or 5A CT, Class 0.5S, pulse out, MID one (1) DO	A9MEM3210
iEM3235 3PH energy meter, DIN rail mount, 1A or 5A CT, Class 0.5S, M-Bus, MID, 4-quadrant energy, one (1) DI, one (1) DO	A9MEM3235
iEM3250 3PH energy meter, DIN rail mount, 1A or 5A CT, Class 0.5S, Modbus	A9MEM3250
iEM3255 3PH energy meter, DIN rail mount, 1A or 5A CT, Class 0.5S, Modbus, MID, 4-quadrant energy, one (1) DI, one (1) DO	A9MEM3255
iEM3265 3PH energy meter, DIN rail mount, 1A or 5A CT, Class 0.5S, BACnet, MID, 4-quadrant energy, one (1) DI, one (1) DO	A9MEM3265
iEM3275 3PH energy meter, DIN rail mount, 1A or 5A CT, Class 0.5S, LON, MID, 4-quadrant energy, one (1) DI, one (1) DO	A9MEM3275
iEM3300 3PH energy meter, DIN rail mount, direct connect 125A, Class 1	A9MEM3300
iEM3310 3PH energy meter, DIN rail mount, direct connect 125A, Class 1, pulse out, MID, one (1) DO	A9MEM3310
iEM3335 3PH energy meter, DIN rail mount, direct connect 125A, Class 1, M-Bus, MID, 4-quadrant energy, one (1) DI, one (1) DO	A9MEM3335
iEM3350 3PH energy meter, DIN rail mount, direct connect 125A, Class 1, Modbus	A9MEM3350
iEM3355 3PH energy meter, DIN rail mount, direct connect 125A, Class 1, Modbus, MID, 4-quadrant energy, one (1) DI, one (1) DO	A9MEM3355
iEM3365 3PH energy meter, DIN rail mount, direct connect 125A, Class 1, BACnet, MID, 4-quadrant energy, one (1) DI, one (1) DO	A9MEM3365
iEM3375 3PH energy meter, DIN rail mount, direct connect 125A, Class 1, LON, MID, 4-quadrant energy, one (1) DI, one (1) DO	A9MEM3375
iEM3455 3PH energy meter, DIN rail mount, LVCT, Class 0.5S, Modbus, MID, 4-quadrant energy, one (1) DI, one (1) DO	A9MEM3455
iEM3465 3PH energy meter, DIN rail mount, LVCT, Class 0.5S, BACnet, MID, 4-quadrant energy, one (1) DI, one (1) DO	A9MEM3465
iEM3555 3PH energy meter, DIN rail mount, Rogowski coil, Class 0.5S, Modbus, MID, 4-quadrant energy, one (1) DI, one (1) DO	A9MEM3555
iEM3565 3PH energy meter, DIN rail mount, Rogowski coil, Class 0.5S, BACnet, MID, 4-quadrant energy, one (1) DI, one (1) DO	A9MEM3565

[13] Available on iEM3455, iEM3465, iEM3555, iEM3565 models only

### Multiple Meter Unit Enclosures for iEM3000 Energy Meters

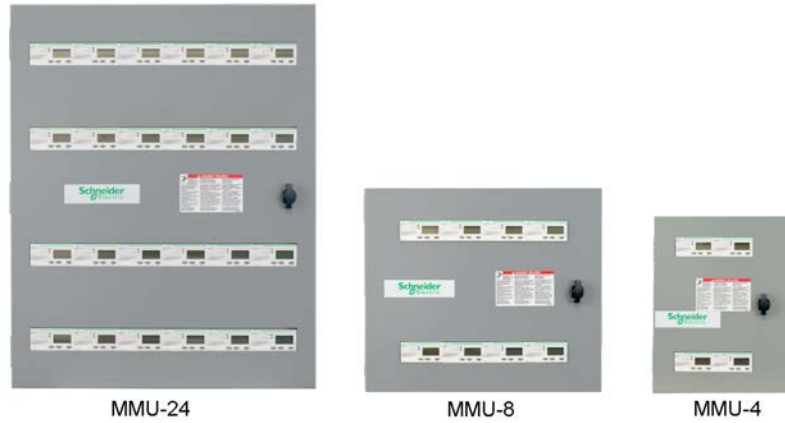

Schneider Electric's Multi-Meter Unit (MMU) enclosures are the ideal complement for the iEM3000 Series of energy meters. This compact solution saves wall space and is scalable for the exact number of meters required. Factory-assembled, pre-wired, and tested enclosures can speed installation, reduce the amount of field wiring, and save time troubleshooting.

Multi-meter unit enclosures and iEM3000 meters provide the highest quality, best value hardware for tenant sub-metering, and are designed for contractor convenience and simplicity.

MMU enclosures are available in three sizes:

- Small MMU enclosures with capacity for up to 4 iEM3000 meters.
- Medium size MMU enclosures with capacity for up to 8 iEM3000 meters, plus one gateway/data logger/energy server.
- Extra-large MMU enclosures with capacity for up to 24 iEM3000 meters, plus one gateway/ data logger/energy server.

Multi meter units are configured to order as described below.

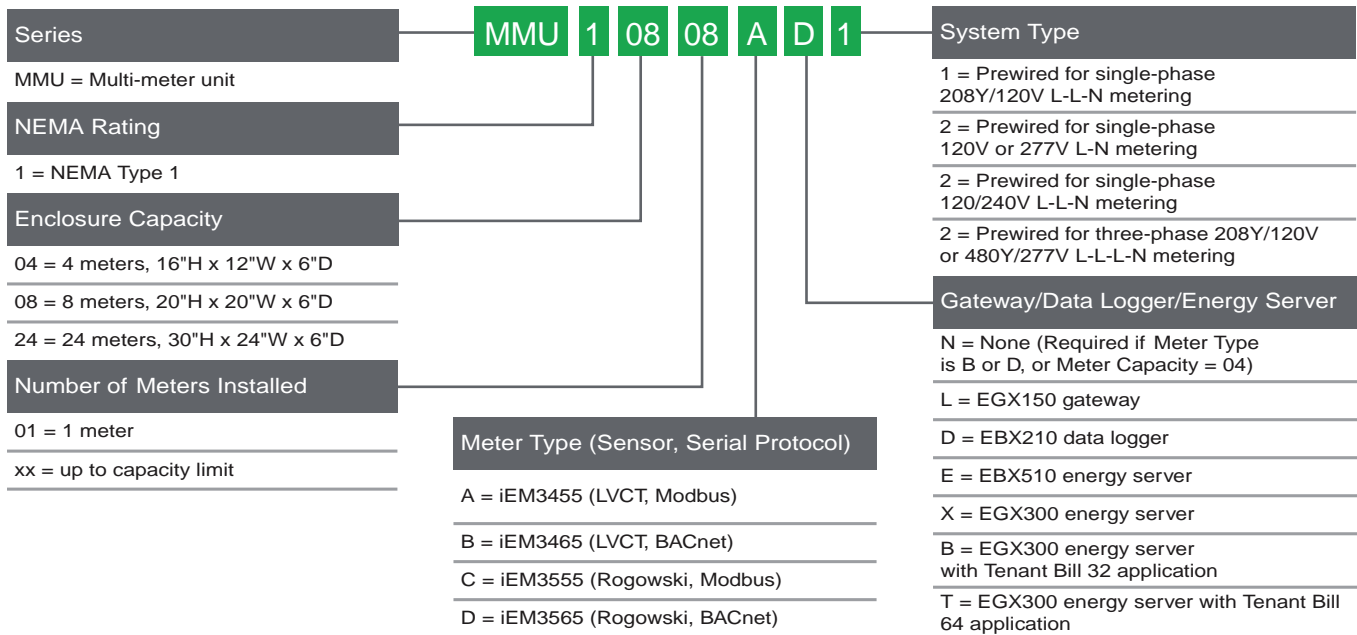

**Power and Energy Meter Selection**

Features [14]	PM5600	PM5500	PM5340	PM5330	PM5110	PM2x30	PM2x20	PM2x10	EM3500	PM3000	iEM3000
<b>Inputs, outputs and control power</b>											
3-phase / single-phase	*/*	*/*	*/*	*/*	*/*	*/*	*/*	*/*	*/*	*/*	*/*
Digital in and out / analog in and out	6 / 0	6 / 0	4 / 0	4 / 0	1 / 0	option	option	option	2 or 3 / 0	up to 2/2	up to 1/1
Power supply options	AC/DC	AC/DC/ LVDC	AC/DC	AC/DC	AC/DC	AC/DC	AC/DC	AC/DC	AC/DC	AC/DC	AC
<b>Power and energy measurements</b>											
Voltage, current, frequency, power factor	*	*	*	*	*	*	*	*	*	*	*
Power / Demand	*/*	*/*	*/*	*/*	*/*	*/*	*/*	*/*	*/*	*/*	*/-
Energy / time-of-use (energy per shift)	*/*	*/*	*/*	*/*	*/-	*/*	*/*	*/*	-/-	*/*	*/*
IEC / ANSI energy accuracy class (% of reading)	0.2	0.2	0.5	0.5	0.5	0.5	1.0	1.0	0.2	0.5	0.5
Loss compensation	-	-	-	-	-	-	-	-	-	-	-
<b>Power quality analysis</b>											
EN50160 compliance reporting / IEC 61000-4-30 Class A or S	-/-	-/-	-/-	-/-	-/-	-/-	-/-	-/-	-/-	-/-	-/-
Flicker measurement	-	-	-	-	-	-	-	-	-	-	-
Transient detection duration	-	-	-	-	-	-	-	-	-	-	-
Sag and swell monitoring / disturbance direction detection	*/-	-/-	-/-	-/-	-/-	-/-	-/-	-/-	-/-	-/-	-/-
Harmonic distortion: total/ individual / inter	*/*/-	*/*/-	*/*/-	*/*/-	*/*/-	*/*/-	*/*/-	*/*/-	-/-/-	*/*/-	-/-/-
Waveform capture	yes	-	-	-	-	-	-	-	-	-	-
<b>On-board data and event logging</b>											
Trending / forecasting / billing	-/-/-	-/-/-	-/-/-	-/-/-	-/-/-	-/-/-	-/-/-	-/-/-	-/-/-	-/-/-	-/-/-
Minimum and maximum	*	*	*	*	*	*	*	*	*	*	*
Events and alarms with timestamps	*	*	*	*	*	*	*	*	*	*	*
Timestamp resolution (seconds)	1	1	1	1	1	1	1	1	1	1	1
Time sync: Network / GPS / IRIG-B / DCF77-B	-/-/-/-	-/-/-/-	-/-/-/-	-/-/-/-	-/-/-/-	-/-/-/-	-/-/-/-	-/-/-/-	-/-/-/-	-/-/-/-	-/-/-/-
<b>Setpoints, alarms and control</b>											
Log alarm conditions / call out on alarm	*/*	*/*	*/*	*/-	*/-	*/-	*/-	*/-	-/-	*/-	-/-
Trigger data logging / waveform capture	-/-	-/-	-/-	-/-	-/-	-/-	-/-	-/-	-/-	-/-	-/-
Trigger relay or digital output	*	*	*	*	*	*	*	*	*	*	*
<b>Special features</b>											
Custom programming	-	-	-	-	-	-	-	-	-	-	-
Downloadable firmware	*	*	*	*	*	*	*	*	*	*	*
<b>Communications</b>											
<b>Ports:</b>											
Ethernet: Copper / Fiber	2/-	2/-	1/-	-/-	-/-	-/-	-/-	-/-	-/-	-/-	-/-
Ethernet-to-serial gateway	*	*	-	-	-	-	-	-	-	-	-
Telephone modem	-	-	-	-	-	-	-	-	-	-	-
Modem-to-serial gateway	-	-	-	-	-	-	-	-	-	-	-
Infrared port	-	-	-	-	-	-	-	-	-	-	-
RS485/RS232	*/-	*/-	-/-	*/-	*/-	*/-	*/-	-/-	*/-	*/-	*/-
Misc: Web server / Email / SNMP / XML	*/*/*/-	*/*/*/-	-/-/-/-	-/-/-/-	-/-/-/-	-/-/-/-	-/-/-/-	-/-/-/-	-/-/-/-	-/-/-/-	-/-/-/-
Protocols: Modbus / DNP / MV-90 / DLMS	*/-/-/-	*/-/-/-	*/-/-/-	*/-/-/-	*/-/-/-	*/-/-/-	*/-/-/-	-/-/-/-	*/-/-/-	*/-/-/-	*/-/-/-
Protocols: IEC61850 / Jbus / M-Bus / LON / BACnet	-/-/-/-/*	-/-/-/-/*	-/-/-/-/*	-/-/-/-/-	-/-/-/-/-	-/-/-/-/-	-/-/-/-/-	-/-/-/-/-	-/-/-/-/*	-/-/-/-/-	-/-/*/*/*

[14] Specifications represent maximum capabilities with all options installed. Some options are not available concurrently. This is not a complete feature list, please refer to detailed product specifications.



EM4200 Flex Power Meter



EM4200 System Calibrated with Calibrated Rogowski Coils

### PowerLogic™ EM4200 Enercept Meter

Next generation Enercept meters provide a unique solution for measuring energy data. The small form factor enables retrofit installation in existing panels to save wall space, installation time, and material cost.

Designed to simplify the ordering process, the meter is available in two major options:

- **System calibrated Enercept** offers the simplest way to order. The meter comes with pre-mounted low voltage (LVCT) or Rogowski coil current transducers, as well as pre-mounted fuse packs. Ordering one part number provides a system calibrated 1% overall accuracy metering system for 100 A, 200 A, 400 A, or 5,000 A range applications.
- **Enercept Flex** offers the flexibility required for many sites where selecting the type and size of current transducer is desired. The Enercept Flex is compatible with the current transducers on . Choose split core or solid core LVCTs from [Table 4.14 LVCT Series Current Transformers, page 4-16](#), or rope style current transducers from [Table 4.13 METSECTR Series Rope-Style Current Transformers, page 4-16](#).

#### Features

- Uni- and bi-directional metering to support to power generation application
- Data logging
- Modbus™ and BACnet serial communication with auto-protocol and baud rate detection.
- Configurable with or without power
- Compact size for easy in-panel mounting, DIN rail or screw mount options, includes mounting brackets for easy installation
- Seamless integration with EcoStruxure™ Power Management software products.
- Wide 90 to 480 Vac input range
- High reliability with ANSI C12.20 0.2% accuracy, IEC 62053-22 Class 0.2S (EM4236)

Table 4.21: EM4200 Enercept Meter

Description	Catalog Number
Enercept Flex power meter, Class 0.2S, Modbus/BACnet RS485, ANSI wire code, compatible with LVCT and Rogowski coils, order current transducers and fuse packs separately	METSEEM4236
System calibrated Enercept power meter, Modbus/BACnet RS485, ANSI wire code, includes 12-inch length Rogowski coil current transducers for up to 5,000 A and fuse packs	METSEEM4236A12
System calibrated Enercept power meter, Modbus/BACnet RS485, ANSI wire code, includes 18-inch length Rogowski coil current transducers for up to 5,000 A and fuse packs	METSEEM4236A18
System calibrated Enercept power meter, Modbus/BACnet RS485, ANSI wire code, includes LVCT current transducers for up to 100 A and fuse packs	METSEEM4236B101
System calibrated Enercept power meter, Modbus/BACnet RS485, ANSI wire code, includes LVCT current transducers for up to 200 A and fuse packs	METSEEM4236B201
System calibrated Enercept power meter, Modbus/BACnet RS485, ANSI wire code, includes LVCT current transducers for up to 400 A and fuse packs	METSEEM4236B401

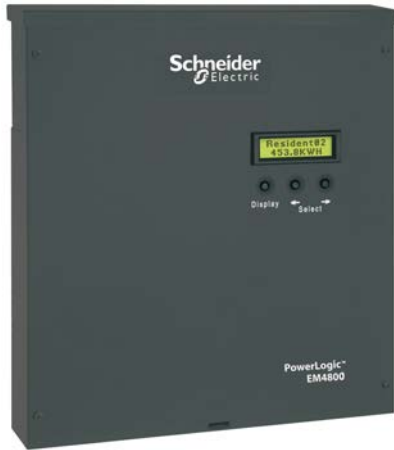

### Multi Circuit Energy Meters

The PowerLogic™ EM4800 and EM4000 multi-circuit energy meters combine accurate electricity sub-metering with advanced communications technology. They are ideal for multi-tenant or departmental metering and M&V applications within office towers, condominiums, apartment buildings, shopping centers and other multipoint environments, or small footprint retail. This meter is available separately or as part of a Square D integrated power center (IPC) for use in building retrofits or new construction.

Each compact multipoint meter provides energy measurement for up to 24 (1CT) or 12 (2CT) single-phase circuits or 8 (3CT) 3-phase circuits. Select a model to match the desired CT type. The 0.333 V output CT option does not require shorting blocks, making it the ideal choice for retrofit installations.

All meters have an accuracy of Class 0.5%, have onboard interval logging, and feature flexible communication options with an Ethernet port that supports multiple protocols: Modbus™ TCP/IP, HTTP, BACnet/IP, FTP, and SNTP. EM4800 series meters have a V.90 modem while EM4000 series meters provide Modbus RTU over RS-485.

Table 4.22: Multi Circuit Energy Meters

Description	Catalog No.
EM4800 series; Ethernet; modem; compatible with 80mA low-power CTs; 120V control power 60 Hz	<a href="#">METSEEM488016</a>
EM4800 series; Ethernet; modem; compatible with 333mV low-power CTs; 120V control power 60 Hz	<a href="#">METSEEM483316</a>
EM4800 series; Ethernet; modem; compatible with standard 5A CTs; 120V control power 60 Hz	<a href="#">METSEEM480516</a>
EM4000 series; Ethernet; Modbus RTU over RS-485; compatible with 80mA low-power CTs; 120V control power 60 Hz	<a href="#">METSEEM408016</a>
EM4000 series; Ethernet; Modbus RTU over RS-485; compatible with 80mA low-power CTs; 277V control power 60 Hz	<a href="#">METSEEM408036</a>
EM4000 series; Ethernet; Modbus RTU over RS-485; compatible with 333mV low-power CTs; 120V control power 60 Hz	<a href="#">METSEEM403316</a>
EM4000 series; Ethernet; Modbus RTU over RS-485; compatible with 333mV low-power CTs; 277V control power 60 Hz	<a href="#">METSEEM403336</a>
200 A current transformer (CT), 80 mA secondary, solid-core (1 CT)	<a href="#">METSECT80200</a>
400 A current transformer (CT), 80 mA secondary, solid-core (1 CT)	<a href="#">METSECT80400</a>
600 A current transformer (CT), 80 mA secondary, solid-core (1 CT)	<a href="#">METSECT80600</a>
50 A .333 V Split Core Current Transformer with 0.75 in Window Size	<a href="#">ECT075050SC</a>
100 A .333 V Split Core Current Transformer with 0.75 in Window Size	<a href="#">ECT075100SC</a>
150 A .333 V Split Core Current Transformer with 0.75 in Window Size	<a href="#">ECT075150SC</a>
200 A .333 V Split Core Current Transformer with 0.75 in Window Size	<a href="#">ECT075200SC</a>
100 A .333 V Split Core Current Transformer with 1.25 in Window Size	<a href="#">ECT125100SC</a>
150 A .333 V Split Core Current Transformer with 1.25 in Window Size	<a href="#">ECT125150SC</a>
200 A .333 V Split Core Current Transformer with 1.25 in Window Size	<a href="#">ECT125200SC</a>
400 A .333 V Split Core Current Transformer with 1.25 in Window Size	<a href="#">ECT125400SC</a>
200 A .333 V Split Core Current Transformer with 2.00 in Window Size	<a href="#">ECT200200SC</a>
400 A .333 V Split Core Current Transformer with 2.00 in Window Size	<a href="#">ECT200400SC</a>
600 A .333 V Split Core Current Transformer with 2.00 in Window Size	<a href="#">ECT200600SC</a>
600 A .333 V Split Core Current Transformer with 3 x 5 in Window Size	<a href="#">ECT300600SC</a>
800 A .333 V Split Core Current Transformer with 3 x 5 in Window Size	<a href="#">ECT300800SC</a>



### PowerLogic Branch Circuit Power Meter

The ideal solution for data center managers, energy or facility managers, engineers and operational executives who are responsible for delivering power to critical applications. In corporate and hosted data center facilities, this technology helps you plan and optimize the critical power infrastructure to meet the demands of continuous availability.

The PowerLogic™ BCPM is a highly accurate, full-featured metering product designed for the unique, multi-circuit and minimal space requirements of a high performance power distribution unit (PDU) or remote power panel (RPP). It offers class 1 (1%) power and energy system accuracy (including 50 A or 100 A CTs) on all branch channels.

The BCPM monitors up to 84 branch circuits with a single device and also monitors the incoming power mains to provide information on a complete PDU. It also offers multi-phase measurement totals with flexible support for any configuration of multi-phase breakers. Full alarming capabilities ensure that potential issues are dealt with before they become problems.

Unlike products designed for specific hardware, the flexible BCPM will fit any PDU or RPP design and supports both new and retrofit installations. It has exceptional dynamic range and accuracy, and optional feature sets to meet the energy challenges of mission critical data centers.

#### Key Features:

- Integrated Ethernet with advanced SNMP, BACnet, and Modbus TCP support on BCPME models
- Class 1% system accuracy (including 50 A or 100 A branch CTs)
- Flexible configuration of Logical Meters for multi-phase loads
- Full PDU monitoring
- Flexible configuration
- Split core version for retrofit installations
- Wide monitoring range
- Low current monitoring
- Advanced alarming
- Easily integrates into a PowerLogic system or other existing networks using Modbus™ communications

Table 4.23: BCPM with Solid-Core CTs

Description	Catalog Number
42-circuit solid-core power & energy meter, 100 A CTs (2 strips), ¼ in. spacing	BCPMA042S
84-circuit solid-core power & energy meter, 100 A CTs (4 strips), ¼ in. spacing	BCPMA084S
42-circuit solid-core power & energy meter, 100 A CTs (2 strips), 1 in. spacing	BCPMA142S
84-circuit solid-core power & energy meter, 100 A CTs (4 strips), 1 in. spacing	BCPMA184S
24-circuit solid-core power & energy meter, 100 A CTs (2 strips), 18 mm spacing	BCPMA224S
36-circuit solid-core power & energy meter, 100 A CTs (2 strips), 18 mm spacing	BCPMA236S
42-circuit solid-core power & energy meter, 100 A CTs (2 strips), 18 mm spacing	BCPMA242S
48-circuit solid-core power & energy meter, 100 A CTs (4 strips), 18 mm spacing	BCPMA248S
72-circuit solid-core power & energy meter, 100 A CTs (4 strips), 18 mm spacing	BCPMA272S
84-circuit solid-core power & energy meter, 100 A CTs (4 strips), 18 mm spacing	BCPMA284S
42-circuit solid-core branch current, mains power meter, 100 A CTs (2 strips), ¼ in. spacing	BCPMB042S
84-circuit solid-core branch current, mains power meter, 100 A CTs (4 strips), ¼ in. spacing	BCPMB084S
42-circuit solid-core branch current, mains power meter, 100 A CTs (2 strips), 1 in. spacing	BCPMB142S
84-circuit solid-core branch current, mains power meter, 100 A CTs (4 strips), 1 in. spacing	BCPMB184S
24-circuit solid-core branch current, mains power meter, 100 A CTs (2 strips), 18 mm spacing	BCPMB224S
36-circuit solid-core branch current, mains power meter, 100 A CTs (2 strips), 18 mm spacing	BCPMB236S
42-circuit solid-core branch current, mains power meter, 100 A CTs (2 strips), 18 mm spacing	BCPMB242S
48-circuit solid-core branch current, mains power meter, 100 A CTs (4 strips), 18 mm spacing	BCPMB248S
72-circuit solid-core branch current, mains power meter, 100 A CTs (4 strips), 18 mm spacing	BCPMB272S
84-circuit solid-core branch current, mains power meter, 100 A CTs (4 strips), 18 mm spacing	BCPMB284S
42-circuit solid-core branch current meter, 100 A CTs (2 strips), ¼ in. spacing	BCPMC042S
84-circuit solid-core branch current meter, 100 A CTs (4 strips), ¼ in. spacing	BCPMC084S
42-circuit solid-core branch current meter, 100 A CTs (2 strips), 1 in. spacing	BCPMC142S
84-circuit solid-core branch current meter, 100 A CTs (4 strips), 1 in. spacing	BCPMC184S
24-circuit solid-core branch current meter, 100 A CTs (2 strips), 18 mm spacing	BCPMC224S
36-circuit solid-core branch current meter, 100 A CTs (2 strips), 18 mm spacing	BCPMC236S
42-circuit solid-core branch current meter, 100 A CTs (2 strips), 18 mm spacing	BCPMC242S
48-circuit solid-core branch current meter, 100 A CTs (4 strips), 18 mm spacing	BCPMC248S
72-circuit solid-core branch current meter, 100 A CTs (4 strips), 18 mm spacing	BCPMC272S
84-circuit solid-core branch current meter, 100 A CTs (4 strips), 18 mm spacing	BCPMC284S
42-circuit solid-core power & energy meter w/ Ethernet, 100 A CTs (2 strips), ¼ in. spacing	BCPME042S
84-circuit solid-core power & energy meter w/ Ethernet, 100 A CTs (4 strips), ¼ in. spacing	BCPME084S
42-circuit solid-core power & energy meter w/ Ethernet, 100 A CTs (2 strips), 1 in. spacing	BCPME142S
84-circuit solid-core power & energy meter w/ Ethernet, 100 A CTs (4 strips), 1 in. mm spacing	BCPME184S
24-circuit solid-core power & energy meter w/ Ethernet, 100 A CTs (2 strips), 18 mm spacing	BCPME224S
36-circuit solid-core power & energy meter w/ Ethernet, 100 A CTs (2 strips), 18 mm spacing	BCPME236S
42-circuit solid-core power & energy meter w/ Ethernet, 100 A CTs (2 strips), 18 mm spacing	BCPME242S
48-circuit solid-core power & energy meter w/ Ethernet, 100 A CTs (4 strips), 18 mm spacing	BCPME248S
72-circuit solid-core power & energy meter w/ Ethernet, 100 A CTs (4 strips), 18 mm spacing	BCPME272S
84-circuit solid-core power & energy meter w/ Ethernet, 100 A CTs (4 strips), 18 mm spacing	BCPME284S



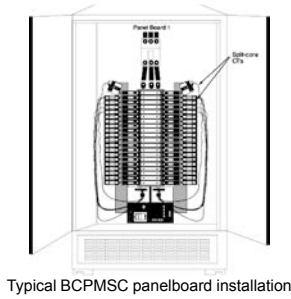

**Table 4.24: BCPM with Split-Core CTs**

Description	Catalog Number
42-circuit split-core power and energy meter, CTs and cables sold separately	BCPMSCA1S
84-circuit split-core power and energy meter, CTs and cables sold separately	BCPMSCA2S
30-circuit split-core power and energy meter, (30) 50 A CTs & (2) 4 ft. cables	BCPMSCA30S
42-circuit split-core power and energy meter, (42) 50 A CTs & (2) 4 ft. cables	BCPMSCA42S
60-circuit split-core power and energy meter, (60) 50 A CTs & (4) 4 ft. cables	BCPMSCA60S
42-circuit split core power and energy meter, all boards on backplate, CTs and cables sold separately	BCPMSCAY63S
84-circuit split-core power and energy meter, with (84) 50 A CTs & (4) 4 ft. cables	BCPMSCA84S
42-circuit split-core branch current, mains power meter, CTs and cables sold separately	BCPMSCB1S
84-circuit split-core branch current, mains power meter, CTs and cables sold separately	BCPMSCB2S
30-circuit split-core branch current, mains power meter, (30) 50 A CTs & (2) 4 ft. cables	BCPMSCB30S
42-circuit split-core branch current, mains power meter, (42) 50 A CTs & (2) 4 ft. cables	BCPMSCB42S
60-circuit split-core branch current, mains power meter, (60) 50 A CTs & (4) 4 ft. cables	BCPMSCB60S
42-circuit split-core branch current, mains, all boards on backplate, CTs and cables sold separately	BCPMSCBY63S
84-circuit split-core branch current, mains power meter, (84) 50 A CTs & (4) 4 ft. cables	BCPMSCB84S
42-circuit split-core current meter, CTs and cables sold separately	BCPMSCC1S
84-circuit split-core current meter, CTs and cables sold separately	BCPMSCC2S
30-circuit split-core current meter, (30) 50 A CTs & (2) 4 ft. cables	BCPMSCC30S
42 circuit split-core current meter, (42) 50 A CTs & (2) 4 ft. cables	BCPMSCC42S
60-circuit split-core current meter, (60) 50 A CTs & (4) 4 ft. cables	BCPMSCC60S
42-circuit split-core current meter, all boards on backplate, CTs and cables sold separately	BCPMSCCY63S
84-circuit split-core current meter, (84) 50 A CTs & (4) 4 ft. cables	BCPMSCC84S
42-circuit split-core power and energy meter w/ Ethernet, CTs and cables sold separately	BCPMSCCE1S
84-circuit split-core power and energy meter w/ Ethernet, CTs and cables sold separately	BCPMSCCE2S
30-circuit split-core power and energy meter w/ Ethernet, (30) 50 A CTs & (2) 4 ft. cables	BCPMSCCE30S
42-circuit split-core power and energy meter w/ Ethernet, (42) 50 A CTs & (2) 4 ft. cables	BCPMSCCE42S
60-circuit split-core power and energy meter w/ Ethernet, (60) 50 A CTs & (4) 4 ft. cables	BCPMSCCE60S
84-circuit split-core power and energy meter w/ Ethernet, (84) 50 A CTs & (4) 4 ft. cables	BCPMSCCE84S

**Table 4.25: 1/3 V Low-Voltage Split-Core CTs for Aux Inputs (Mains)**

Amperage Rating	Inside Dimensions	Catalog Number
50 A	10 x 11 mm	LVCT00050S
200 A	16 x 20 mm	LVCT00101S
200 A	32 x 32 mm	LVCT00202S
100 A	30 x 31 mm	LVCT00102S
200 A	30 x 31 mm	LVCT00202S
300 A	30 x 31 mm	LVCT00302S
400 A	62 x 73 mm	LVCT00403S
600 A	62 x 73 mm	LVCT00603S
800 A	62 x 73 mm	LVCT00803S
800 A	62 x 139 mm	LVCT00804S
1000 A	62 x 139 mm	LVCT01004S
1200 A	62 x 139 mm	LVCT01204S
1600 A	62 x 139 mm	LVCT01604S
2000 A	62 x 139 mm	LVCT02004S
2400 A	62 x 139 mm	LVCT02404S

**Table 4.26: 1/3 V Low-Voltage Solid-Core CTs for Aux Inputs (Mains)**

Amperage Rating	Inside Dimensions	Catalog Number
50 A	10 mm	LVCT20050S
100 A	10 mm	LVCT20100S
200 A	25 mm	LVCT20202S
400 A	31 mm	LVCT20403S

**Table 4.27: BCPM Split-Core Branch CTs and Adapter Boards**

Description	Catalog Number
BCPM adapter boards, quantity 2, for split core BCPM	BCPMSCADPBS
BCPM 50 A split core CTs, Quantity 6, 1.8 m lead lengths	BCPMSCCT0
BCPM 50 A split core CTs, quantity 6, 6 m lead lengths	BCPMSCCT0R20
BCPM 100 A split core CTs, Quantity 6, 1.8 m lead lengths	BCPMSCCT1
BCPM 100 A split core CTs, Quantity 6, 6 m lead lengths	BCPMSCCT1R20
BCPM 200 A split core CTs, Quantity 1, 1.8 m lead lengths	BCPMSCCT3
BCPM 200 A split core CTs, Quantity 1, 6 m lead lengths	BCPMSCCT3R20

**Table 4.28: Additional Accessories for use with BCPM Products**

Description	Catalog Number
BCPM circuit board cover	BCPMCOVERS
CT repair kit for solid core BCPM (includes one CT)	BCPMREPAIR
Additional 100 A split core CT for use with solid core repair kit	H6803R-0100
Modbus to BACnet protocol converter	E8951
Flat Ribbon cable (quantity 1) for BCPM, length = 0.45 m	CBL008
Flat Ribbon cable (quantity 1) for BCPM, length = 1.2 m	CBL016
Flat Ribbon cable (quantity 1) for BCPM, length = 1.5 m	CBL017
Flat Ribbon cable (quantity 1) for BCPM, length = 1.8 m	CBL018
Flat Ribbon cable (quantity 1) for BCPM, length = 2.4 m	CBL019
Flat Ribbon cable (quantity 1) for BCPM, length = 3.0 m	CBL020
Flat Ribbon cable (quantity 1) for BCPM, length = 6.1 m	CBL021
Round Ribbon cable (quantity 1) for BCPM, length = 0.5 m	CBL031
Round Ribbon cable (quantity 1) for BCPM, length = 1.2 m	CBL022
Round Ribbon cable (quantity 1) for BCPM, length = 2.4 m	CBL033
Round Ribbon cable (quantity 1) for BCPM, length = 3 m	CBL023
Round Ribbon cable (quantity 1) for BCPM, length = 6.1 m	CBL024

*New!*

### PowerLogic™ EM4900 Series Multi-Circuit Meters

The PowerLogic™ EM4900 Series Multi-Circuit Meters make it easy to add many metering points without having to purchase, mount, wire and commission individual energy meters. Simply add a single device with common voltage inputs and energy communication interface that can measure the current, voltage, power, energy consumption, and Total harmonic Distortion (THD) of up to (14) 3-phase circuits with a single board or up to (28) 3-phase circuits with a two board configuration. Save on both equipment cost and installation.

#### Applications

- Commercial and residential subtenant billing
- Load-based cost allocation
- Measuring for load balancing and demand response
- Overload protection



EM49xxE Main Unit

**Table 4.29: EM4900 Series Part Numbers - BCPM with Solid Core CTs**

Item	Code	Description
1 Model	METSEEM49	Multi-Circuit Meter
2 Number of 3-phase Meters	04	Up to (4) 3-phase Meters (see Table 4.31 for variations)
	08	Up to (8) 3-phase Meters (see Table 4.31 for variations)
	14	Up to (14) 3-phase Meters (see Table 4.31 for variations)
	28	Up to (28) 3-phase Meters (see Table 4.31 for variations)
3 Communication Interfaces & Protocols	A	RS-485 Serial with Modbus™ RTU (add E8951 for other protocols)
	E	Ethernet with Modbus TCP, BACnet IP and SNMP protocols and RS-485 Serial with Modbus RTU or BACnet IP

**Table 4.30: Part Number Example**



- 1: Model
- 2: Number of 3-phase meters (without neutral current)
- 3: Communication interfaces & protocols.

#### Number of Meters Supported

EM4900 models are all factory-configured as all 3-phase meters (w/o neutral). They can be easily re-configured to any combination of 1-ph, 2-ph, or 3-ph meters (with ION setup). Any unused channels can be used to measure neutral current. Label overlays (to re-number CT connections) are provided for 1-ph/2-ph applications.

**Table 4.31: Number of Meters**

Catalog No.	"E" - Integrated Ethernet	3 PH No Neutral	3 PH With Neutral	2 PH	1 PH
METSEEM4904A	METSEEM4904E	4	3	6	12
METSEEM4908A	METSEEM4908E	8	6	12	24
METSEEM4914A	METSEEM4914E	14	10	21	42
METSEEM4928A	METSEEM4928E	28	21	42	84

**Table 4.32: EM4900 Multi-Circuit Meters**

Catalog No.	EM4900 Multi-Circuit Meters
METSEEM4904A	Multi-Circuit Meter – (4) 3-phase meters - Modbus RTU only
METSEEM4908A	Multi-Circuit Meter – (8) 3-phase meters - Modbus RTU only
METSEEM4914A	Multi-Circuit Meter – (14) 3-phase meters - Modbus RTU only
METSEEM4928A	Multi-Circuit Meter – (28) 3-phase meters - Modbus RTU only
METSEEM4904E	Multi-Circuit Meter – (4) 3-phase meters - Ethernet and Serial (Modbus, BACnet & SNMP)
METSEEM4908E	Multi-Circuit Meter – (8) 3-phase meters - Ethernet and Serial (Modbus, BACnet & SNMP)
METSEEM4914E	Multi-Circuit Meter – (14) 3-phase meters - Ethernet and Serial (Modbus, BACnet & SNMP)
METSEEM4928E	Multi-Circuit Meter – (28) 3-phase meters - Ethernet and Serial (Modbus, BACnet & SNMP)

**Table 4.33: EM4900 Multi-Circuit Meters**

Catalog No.	Description
BCPMCOVERS	EM4900 circuit board cover
E8951	Modbus to BACnet protocol converter
<b>Ribbon cables for 28-meter models</b>	
1.22 m cables are standard – others must be ordered separately	
CBL008	Flat Ribbon cable (quantity 1) for BCPM, length = 0.45 m
CBL016	Flat Ribbon cable (quantity 1) for BCPM, length = 1.2 m
CBL017	Flat Ribbon cable (quantity 1) for BCPM, length = 1.5 m
CBL018	Flat Ribbon cable (quantity 1) for BCPM, length = 1.8 m
CBL019	Flat Ribbon cable (quantity 1) for BCPM, length = 2.4 m
CBL020	Flat Ribbon cable (quantity 1) for BCPM, length = 3.0 m
CBL021	Flat Ribbon cable (quantity 1) for BCPM, length = 6.1 m
CBL022	Round Ribbon cable (quantity 1) for BCPM, length = 1.2 m
CBL023	Round Ribbon cable (quantity 1) for BCPM, length = 3 m
CBL024	Round Ribbon cable (quantity 1) for BCPM, length = 6.1 m
CBL031	Round Ribbon cable (quantity 1) for BCPM, length = 0.5 m
CBL033	Round Ribbon cable (quantity 1) for BCPM, length = 0.8 m



EM49xxA Main Board

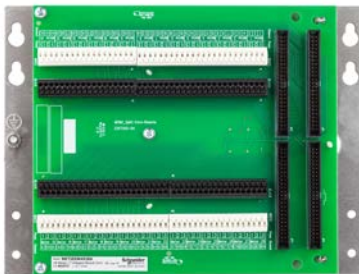

CT Adapter Assembly (28-Meter models only)



Flat ribbon cable



Round ribbon cable

*New!*

**EcoStruxure™ Panel Server**

IoT for an intelligent power network. The EcoStruxure™ Panel Server is the next generation of gateway, providing a seamless connection of wired or unwired smart IoT devices to your edge control software or cloud-based applications and analytics. It is a foundational enabler for Schneider Electric EcoStruxure™ solutions.

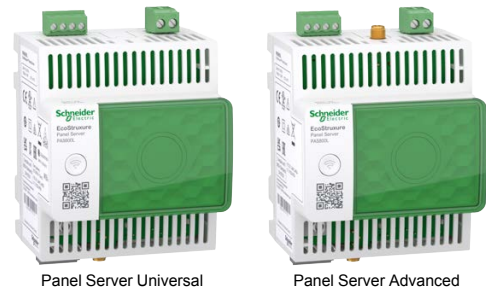

Panel Server Universal

Panel Server Advanced



EcoStruxure Panel Server gives you access to the information you need to help protect, maximize and optimize your power system.

**Electrical safety**

Panel Server is an integral part of Schneider Electric's continuous thermal monitoring application, helping reduce the risk of electrical fires, and helping to increase people and assets protection. Implement the thermal monitoring of your electrical panel by connecting thermal and heat sensors to your Panel Server.

**Power availability**

Electrical distribution monitoring and power event analysis help avoid unplanned downtime caused by electrical failure. Panel Server collects real-time data and alarms, presenting information through embedded web pages, making it available to edge control software or cloud-based applications and analytics for electrical system diagnostics. Use embedded web pages for first-level monitoring or monitor from your edge or cloud control system.

**Optimize energy efficiency**

Improve your facility's energy efficiency and reduce energy consumption with energy usage analysis and performance tracking. Panel Server collects and shares energy data to help achieve your energy conservation initiatives. It is part of an energy data management system certified for compliance with ISO 50001, 50002, 50006 requirements.

**Cybersecurity**

Guarding your electrical assets and systems against cyber attacks is vital. Discover the enhanced cybersecurity benefits of Panel Server and its IEC62443-4-1 compliant development lifecycle. Explore its cybersecurity features through a dedicated guide, and discover how Panel Server empowers you to retrieve security logs, providing valuable insights into system security and activity.

**Architecture Overview**

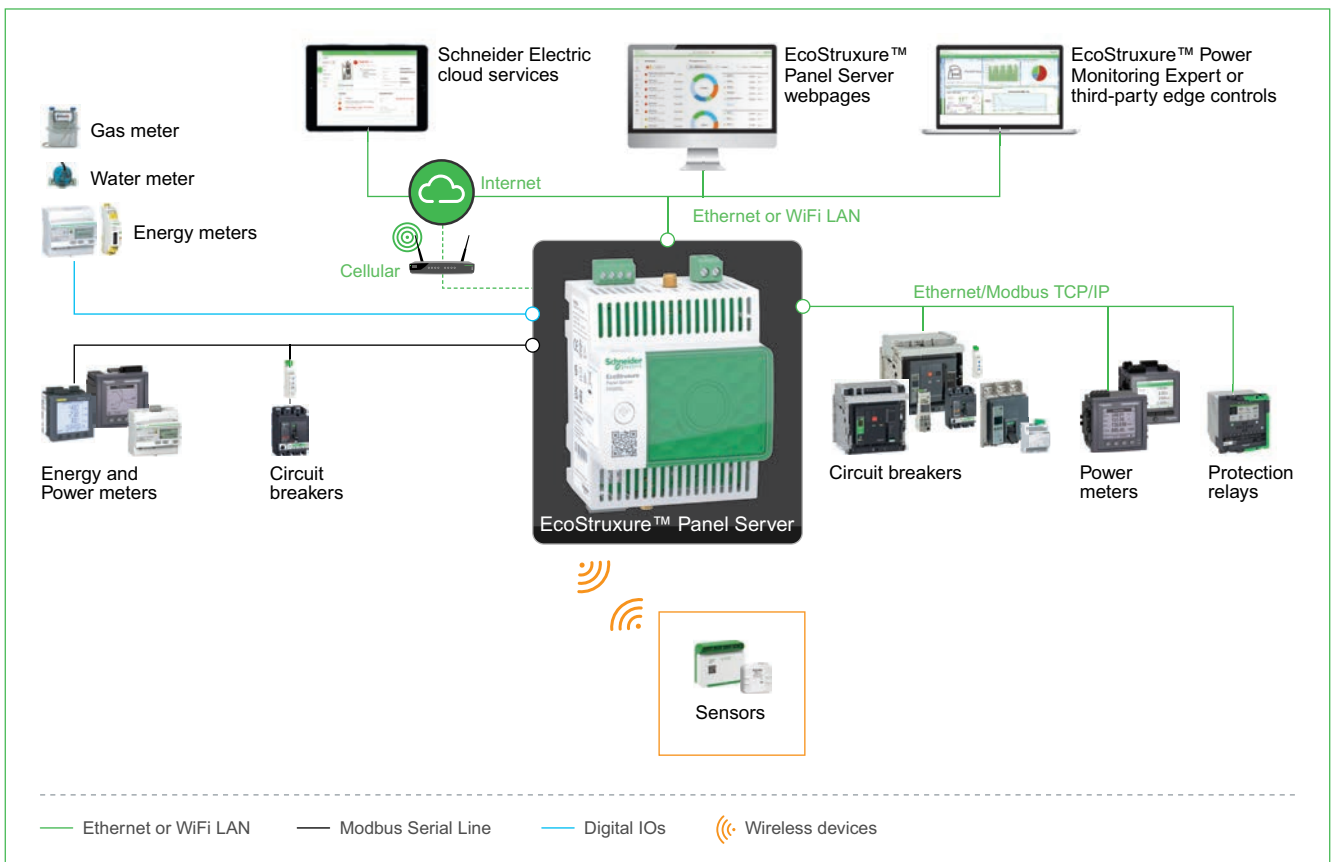



PS600L



PS800L

### Panel Server Universal

Panel Server Universal is designed to retrieve data from wired or wireless devices. For sensitive installations, the Wired-by-Design models only support wired protocols.

#### Functions

- Connect to your monitoring & control software such as EcoStruxure Power Monitoring Expert, EcoStruxure Power Operation, or to your Building Management System.
- Connect to Schneider Electric cloud applications such as EcoStruxure Energy Hub or Asset Advisor.
- Ease of commissioning with EcoStruxure Power Commission software or directly through the Panel Server web pages, enabling device plug-and-play and auto-discovery features.
- Ease of operation with user friendly embedded web pages, and data contextualization for more relevant analytics.

**Table 4.34: EcoStruxure Panel Server Universal**

Description	Catalog Number
Panel Server Universal with 110...277 V AC/ DC power supply	PAS600
Panel Server Universal with 24 V DC power supply	PAS600L
Wired by Design Panel Server Universal with 24 V DC Power	PAS600LWD
Wired by Design Panel Server Universal with PoE power supply	PAS600PWD

Refer to [EcoStruxure Panel Server](http://www.se.com/us) on www.se.com/us for complete information.

### Panel Server Advanced

Panel Server Advanced has Data Logger and Local Energy Server capabilities. It embodies the first step into energy monitoring. Follow, analyze and compare your loads consumption to enable energy savings.

#### Functions

- An all-in-one gateway to retrieve data from both your wireless IEEE 802.15.4 devices and Modbus devices.
- Monitor up to three years history data and analyze your energy consumption directly through the Panel Server Advanced embedded web pages.
- Connect to your monitoring and control software such as EcoStruxure™ Power Monitoring Expert, EcoStruxure™ Power Operation or to your Building Management System.
- Connect to Schneider Electric cloud applications such as EcoStruxure™ Energy Hub or Asset Advisor.
- Ease of commissioning with EcoStruxure™ Power Commission software or directly through the Panel Server web pages, enabling device plug-and-play and auto-discovery features.
- Ease of operation with user friendly embedded web pages, and data contextualizing for more relevant analytics.

**Table 4.35: EcoStruxure Panel Server Advanced**

Description	Catalog Number
Panel Server Advanced with 24 V DC power supply	PAS800L
Panel Server Advanced with PoE power supply	PAS800P
Panel Server Advanced with 110...277 V AC/DC power supply	PAS800

Refer to [EcoStruxure Panel Server](http://www.se.com/us) on www.se.com/us for complete information.

### Panel Server Dimensions

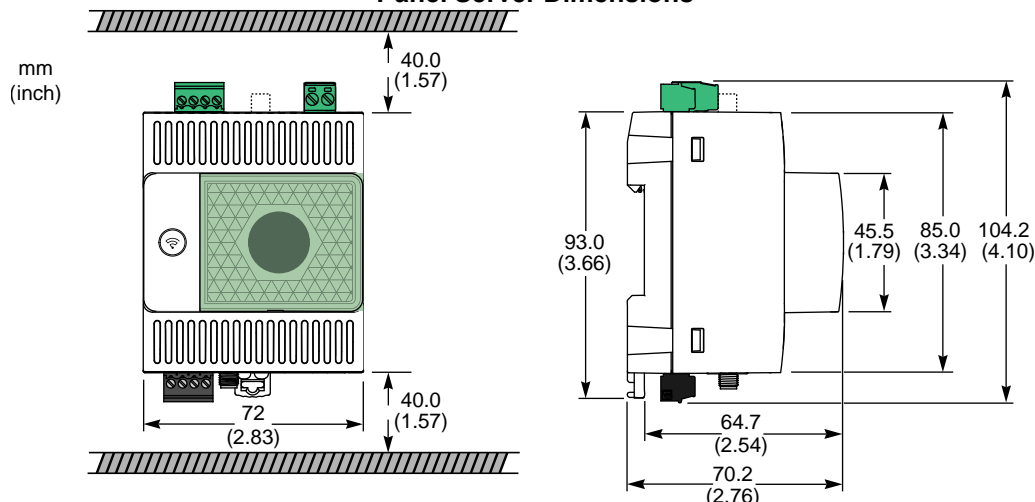

Approximate Dimensions for Universal and Advanced Panel Server

## Engineered Solutions

Schneider Electric provides an engineered solution approach to your specific power system applications. Our total solutions for power monitoring and power system controls allow greater safety, reliability, and energy efficiency of your power systems. As a long standing industry leader in Power Monitoring and Control Systems, we understand your power system requirements and needs.

All of our Engineered Solutions are tailored to your specific system requirements. Schneider Electric is your total solution provider.

### The Basics of a Comprehensive Power and Energy Management System

**Measure:** Gather energy and power data throughout your facility. Stand-alone or embedded meters measure, collect, and deliver essential data from key distribution points across your entire electrical network.

**Understand:** Turn data into actionable information. Power management software brings intelligent analytics and visualization to power and energy data.

**Act:** Use actionable information to make intelligent decisions and operational shifts to create change or correct issues.

### The Benefits of Power and Energy Management

- Reduce energy and operational costs
- Improve power and equipment reliability
- Optimize operations
- Increase system capacity
- Minimize expensive downtime
- Meet sustainability goals
- Improve productivity

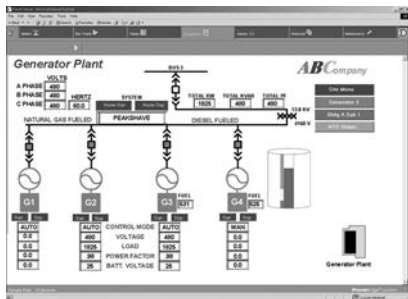

PowerLogic Engineers provide graphic solutions for realtime monitoring of power systems.

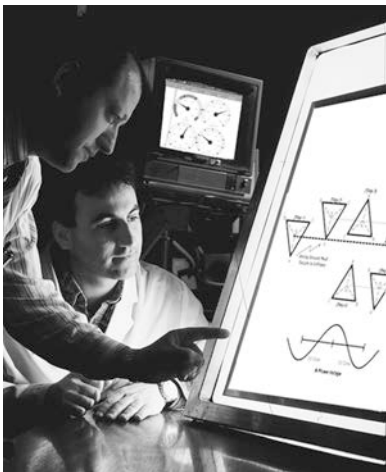

## Power System Control Applications

**Automated solutions for increased Reliability and Energy Efficiency:** Schneider Electric engineers provide Power System Control Applications with automated solutions for addressing your system reliability and efficiency control needs. Our offer covers Automatic Throwover Schemes, Load Shedding/Peak Shaving, and Load Preservation and Microgrids.

- **Automatic Throwover Systems** – Automatic selection of available utility or generator sources to maintain service continuity to connected loads.
- **Load Shedding/Peak Shaving** – Control peak demand levels or ensure service continuity to critical load or operate breakers in accordance with user specified sequences and time delays such as bringing large motors online across several billing kw demand periods to avoid demand penalties.
- **Load Preservation** – Fast acting sophisticated control systems designed to stabilize critical power systems to the greatest extent possible by monitoring frequency and power sources from utility plus generator capacity versus total circuit load.

## Power System Engineering

The Square D™ Power System Engineering team offers a wide range of engineering services to improve the safety, efficiency and reliability of your power distribution system. The team is comprised of registered professional engineers, safety trained and equipped, to perform a variety of engineering functions.

### Power System Studies

The Square D Power System Engineering Team provides expertise for a variety of electrical power system studies. Some of the more common system studies include:

- Short-circuit analysis
- Time-current coordination
- Motor starting/voltage drop
- Motor starting/torque-speed
- Safe motor re-energization
- Harmonic analysis
- Transient analysis
- Power factor correction analysis
- Other system specific analysis

### Arc Flash Analysis

Square D offers on-site services to perform arc flash analysis for a facility, complex, office, or campus. An Arc flash analysis is used to determine:

- Flash Protection Boundary
- Incident Energy Value
- Hazard/Risk Category
- Appropriate Personal Protective Equipment (PPE)
- Low cost arc flash reduction methods

### Features of Square D arc flash analysis include:

- Time current coordination analysis showing both existing and recommended over/current device settings
- Short-circuit study to ensure adequacy of equipment
- Onsite verification and documentation of equipment
- Arc flash labels (populated with the results of the arc flash analysis)
- Arc flash label affixation
- NFPA 70E—Safe Workplace Practices Training provided by OSHA authorized outreach instructors
- Recommendations and solutions to reduce potential arc flash hazards

### Power Quality Studies

Square D offers onsite power quality engineering studies and solutions to eliminate process disruptions, power system shutdowns, and equipment damage due to electrical power system disturbances. A power quality study is used to:

- Determine compliance with the IEEE 519-Recommended Practices and Requirements for Harmonic Control in Electrical Power Systems guidelines
- Identify most cost-effective solution to power quality problems
- Solve process disruptions due to power disturbances
- Reduce economic effects of poor power quality
- Identify disturbances originating on electric utility system and improvements to reduce the number and severity

### Power System Assessment

Square D offers engineering services to meet a variety of power system needs:

- Basic codes and standards compliance
- Protective coordination assessment
- Maintenance program review
- Recommendations for power system optimization
- Power quality troubleshooting and analysis
- Power factor and harmonics analysis
- Electrical safety hazards
- Short-circuit withstand overview
- Single-line documentation of power system
- Power monitoring recommendations
- Loading measurements

### Power System Design Services

Schneider Electric Engineering Services offers three levels of design services based on the customer need:

- Design Assurance
- Design Assistance
- Primary Design Agent

Other areas of expertise include:

- New equipment installation
- Existing equipment modification
- Protection Control Automation
- Ground Fault Systems
- Generator Control Systems

Square D professional engineers - safety trained and equipped - will listen to your concerns and goals, define the problem or enhancement, and engineer the solution that best satisfies your needs.

For additional information on power system engineering services and pricing, contact your nearest Square D/Schneider Electric office.

### Advanced Microgrid Solutions and Distributed Energy Resource Management

With our custom solutions and proven expertise, we deliver advanced microgrids that offer the advantages of grid independence – without forfeiting the benefits of being part of the central grid. Our flexible microgrid architecture features a scalable set of grid components designed to efficiently manage your entire energy infrastructure, including distributed generation, energy storage, and load demand, while giving you the ability to easily adapt the system to your changing needs. **Learn more at [www.schneider-electric.us/en/work/solutions/microgrids/](http://www.schneider-electric.us/en/work/solutions/microgrids/)**

### Total Energy Control

Schneider Electric Certified Energy Managers (CEM's) work on-site with knowledgeable plant personnel to develop a long-term, comprehensive, "Energy Action Plan", that serves as the blueprint for energy savings. Unlike performance contracts or one-time energy audits, the Total Energy Control<sup>SM</sup> program offers a strategic partnership for energy-intensive industrials who want to improve energy efficiency.

### Total Energy Control

- **Utility Analysis:** evaluating both the commodity supply side and the demand side areas of the operation.
- **Demand Side Usage:** profiling facility loads and consumption patterns.
- **Opportunity Identification / Prioritization:** projects that make sense today and those that should be considered in the future as energy prices change.
- **Project Implementation:** Client can choose which projects to implement or Square D can provide turn-key implementation.
- **Supply Management:** forecasting and making adjustments to reflect current conditions.
- **On-Going Accountability:** accountable along with you for the ongoing success of your energy plan.

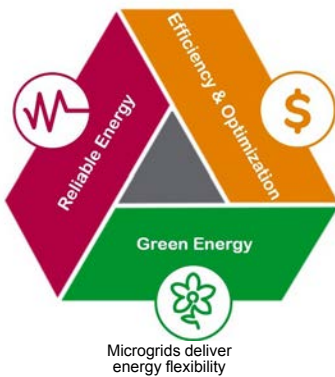
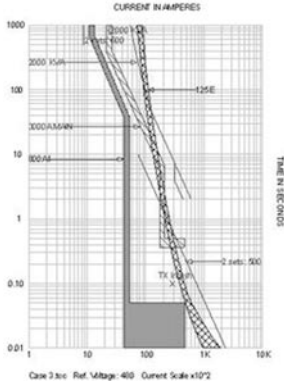



**EcoStruxure™ Service Plans (ESP) for Power Management**

EcoStruxure™ Service Plans (ESP) is a personalized service contract for your connected and non-connected assets. It provides both onsite and off-site asset management, monitoring, diagnostics, and preventive and predictive maintenance services.

ESP for Power Management is designed to provide maintenance, support, and improved services for your Schneider EPMS. Now you can easily manage your electrical system and keep your operations running smoothly without the need for extra time or the manpower to do it.

**Table 4.36: ESP Plan Features**

The table below identifies the three levels and what features would be included or can be added. Multi-year plans available at a discount.

Package Features	Prime			Ultra	
	PrimeLite	Prime	PrimeOS	Ultra0	Ultra1 Ultra2 Ultra3
<b>Support</b>					
Basic Product Support	•	•	•	•	•
Remote Access Troubleshooting	•	•	•	•	•
24/7 support	•	•	•	•	•
Direct Access to L2 Digital Service Engineers	•	•	•	•	•
Customer Success Resource	N/A	•	•	•	•
Designated Digital Service Engineer	N/A	N/A	N/A	•	•
<b>Maintenance</b>					
Software Assurance <i>License cost for service packs and new software releases</i> <sup>[15]</sup>	N/A	•	•	•	•
Remote Maintenance <i>Hours per year</i>	N/A	Up to 4	Up to 4	Up to 8	Up to 8
Onsite Maintenance <i>Days</i>	Available at discount	Available at discount	2 per year	Available at discount	# of days per quarter <sup>[16]</sup>
<b>Optimize</b>					
Self-Help Web Portal	•	•	•	•	•
Exclusive Access to Webinars	•	•	•	•	•
Exclusive Access to Power Monitoring & Energy Management Online School	•	•	•	•	•
Power Advisor Electrical Health & Data Quality Report with Consultation Meeting <sup>[17]</sup> <i>Frequency</i>	N/A	Bi-annual	Bi-annual	Quarterly	Quarterly
PMU Factory Training Discount (Visit <a href="http://www.pmutraining.com/">http://www.pmutraining.com/</a> )	N/A	10%	10%	15%	15%
<b>Transform</b>					
eMaintenance <i>Remote PME Maintenance</i>	Available at discount				
eService <i>Expert Design, Customization, and Upgrade Services</i>					
Cybersecurity Assessment					
Managed System Studies					

[15] Installation and SQL license not included.  
 [16] ULTRA1 = 1 Day, ULTRA2 = 2 Days, ULTRA3 = 3 Days  
 [17] Requires client assistance with metering hierarchy.

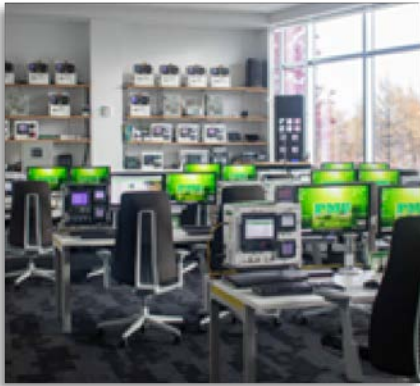

**Power Management University (PMU)**

PMU is the U.S.-based education team dedicated to providing best in class training on the various energy management software and related products that Schneider Electric™ has to offer. We offer a variety of courses to help our end-users make the most out of their energy management software and hardware investments. The table below identifies some of the training options available through PMU.

- Visit <https://www.pmutraining.com/> to learn more or
- Email [pmu@se.com](mailto:pmu@se.com) with any questions.

**Table 4.37: PMU Training Options**

<b>PMU Factory Training Courses</b> Perfect for sites that have minimal staff that need training on their EPMS. PMU Factory Training Courses are instructor-led events with pre-defined agendas and are available for registration by anyone interested. They are hosted at regular intervals throughout the year with both Classroom (CR) and Virtual Instructor-led (VILT) options available for most courses.  Below is the list of PMU Factory Training Courses available. Click on each course name to learn more.		
Course Name	Duration	Part Number (CR) = Classroom (VILT) = Virtual Instructor-led
PowerLogic™ and ION Metering Hardware — Installation and Troubleshooting	2 Days	(CR) 3000PMU2DAY
EcoStruxure™ Power Monitoring Expert – Operator Training	3 Days	(CR) 3000PMU3DAY (VILT) 3000PMUWEB3DAY
EcoStruxure™ Power Monitoring Expert – (PME) Advanced Operator Training	3 Days	(CR) 3000PMU3DAY (VILT) 3000PMUWEB3DAY
EcoStruxure™ Power Monitoring Expert – ION Architecture Programming using Designer	4 Days	(CR) 3000PMU4DAY (VILT) 3000PMUWEB4DAY
EcoStruxure™ Power Monitoring Expert – Energy Billing Module Deployment	1 Day	(VILT) 3000PMUWEB1DAY
EcoStruxure™ Power Monitoring Expert – Vista Graphics and User Diagrams	1 Day	(VILT) 3000PMUWEB1DAY
EcoStruxure™ Power Monitoring Expert – TGML Graphics and User Diagrams	1 Day	(VILT) 3000PMUWEB1DAY
<b>PMU Private Training Events</b> Perfect for sites that have complex systems or multiple staff members that need training on their Schneider Electric EPMS. PMU Private Training sessions are instructor-led events that are designed for your specific solution. With both on-site (at the customer facility) and virtual options available, PMU Private Training Events allow you to choose the date, duration, and topics that are relevant to your system and staff.  Below is the list of PMU Private Training sessions part numbers. Contact your sales representative or Email <a href="mailto:pmu@se.com">pmu@se.com</a> to learn more.		
Location	Part Number	Description
On-site	3000PMUSITE1C	1 Day On-site Private Training Event, up to 10 people, 5X8, Standard Content
	3000PMUSITE2C	2 Day On-site Private Training Event, up to 10 people, 5X8, Standard Content
	3000PMUSITE3C	3 Day On-site Private Training Event, up to 10 people, 5X8, Standard Content
	3000PMUSITE4C	4 Day On-site Private Training Event, up to 10 people, 5X8, Standard Content
	3000PMUCSITEVID	Daily Videography Service Adder for Private On-site Training Events, quantity as needed
	3000PMUCSITE	2nd Instructor for larger Private On-site Training Events, Class Size 11-20 students
Virtual	3000PMUCDVILT1DAY	1 Day Virtual Private Training Event, up to 10 people, 5X8, Standard Content
	3000PMUCDVILT2DAY	2 Day Virtual Private Training Event, up to 10 people, 5X8, Standard Content
	3000PMUCDVILT3DAY	3 Day Virtual Private Training Event, up to 10 people, 5X8, Standard Content
	3000PMUCDVILT4DAY	4 Day Virtual Private Training Event, up to 10 people, 5X8, Standard Content
	3000PMUCVILTVID	Daily Videography Service Adder for Private VILT Events, quantity as needed
N/A	3000PMUCSITEPREP	1 Day of Custom Content Creation, quantity as needed

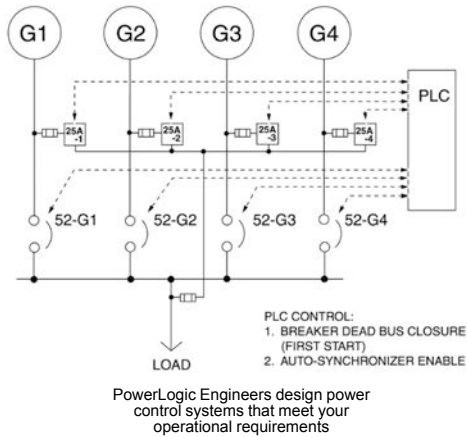

**System Integration  
System Design and Engineering**

Our Power Solutions specialists can work with you to design or upgrade your existing system to best achieve your energy and power management objectives and informational needs. With expertise in electrical systems, communications, and automatic control systems, we can integrate, install, and commission your system for optimal performance.

- System Design and Bill of Material Recommendations
- Power Monitoring and Control
- WAGES (Water, Air, Gas, Electric, Steam)
- Enterprise web-based monitoring
- Specification development, drawings, documentation
- Enclosure panel design and build
- Metering Connection Verification/Testing
- Power distribution automation
- On-Site Installation Assistance, Component Configuration & Startup
- Turn-key project management
- Third Party Device and communication interfaces
- Configured Workstations, User Software Interfaces
- Interactive Graphic Design to mimic facility layout, one-lines, equipment status
- Custom Software, Reports & Applications – Billing and Event Notification



PowerLogic™ Engineers specialize in the design and setup of Emergency Power Supply Systems (EPSS).

For additional information, contact your nearest Square D / Schneider Electric office.

### Factory Assembled Equipment

Square D™ PowerLogic™ Factory Assembled Equipment offers a wide range of designs for metering, communications, and control applications to simplify retrofit installations. Our equipment is designed to order as a free-standing or wallmounted system. With PowerLogic™ Factory Assembled Equipment, you'll receive professionally crafted, factory tested, pre-wired equipment that will greatly improve the speed of your system startup. All backed by the Square D™ quality standard of excellence.



- Assemblies include meters & devices wired to terminal blocks, disconnects, and shorting blocks or test switches
- Tailored to any system voltage :
  - 208/120 V, 480/277 V & 600/347 V Wye
  - 240 V, 480 V & 600 V Delta
  - Utilization of PT's required for higher voltage levels
- Wall mountable and easy to install using concealed holes in the back of the enclosure.
- Complete with necessary documentation and mounting hardware for quick and easy installation
- Carbon steel construction, with industry standard ANSI 61 gray powder coat finish
- Equipped with concealed hinged door, and universal pad-lockable latch.
- Custom engraved nameplates available for all units.

**Table 4.38: Industrial Enclosure Types 12 & 4, UL & CUL 508A Listed**

Available Meter Types	Digital Inputs	Digital Outputs	Analog Inputs	Analog Outputs
PM5563RD	Up to 4 / Meter	Up to 2 / Meter	N/A	N/A
PM8244	Up to 15 / Meter	Up to 5 / Meter	Up to 4 / Meter	Up to 2 / Meter

- Supports Single or Multiple Voltage Sources for Indoor (Types 1 and 12) & Outdoor (Type 4) applications
- Available with 1–4 meters per panel. Serial & Ethernet Communications are options for all units
- EGX & ION RTU Communication Enclosures with 1–4 devices per panel also available





**Light Industrial Enclosure Type 1, UL & CUL 508A Listed**

- Available for the following meter types: PM8244, PM5563RD, and ION6200
- Supports Single Voltage Source only for Indoor (Type 1) applications.
- Available with 1–12 meters per panel. Serial Communications are standard for all units.
- No Digital or Analog I/O is available for this option.

**Service Entrance/Utility Socket Enclosure Type 3R, UL & CUL 508A Listed**

- Available for ION8650 only, with up to 3 Digital Inputs and 4 Digital Outputs.
- Supports Single Voltage Source only for Indoor & Outdoor (Type 3R) applications.
- Units are Ring Type with removable cover.
- Available with 1 meter per panel. Serial & Ethernet Communications options available.
- Supports Form 9S, 35S, 36S, 39S and 76S configurations for ION8600 and forms 9S and 36S for E5600.
- Options available for remote mounted CTs
- Options available for integrated, bar type CTs
- Optional Test Switch.

**Additional engineered to order products are available for a wide variety of design solutions.**

- Switchgear Transfer Control Panels
- Generator Control Panels
- Load Shed Control Panels
- Sequence of Events Recording (SER) Panels
- Control System Mimic Panels
- Lighting Control Interface Panels
- Programmable Logic Controller (PLC) Control Panels (Hot Standby, Relay Control, Data Concentration etc. ...)
- Emergency Power Supply Systems (EPSS) Control Panels
- Water, Air, Gas, Electrical, and Steam (WAGES) Monitoring Panels
- Input Status Monitoring & Alarming Panels
- Remote Annunciator Control Panels
- Remote Operator Control Panels
- Serial, Ethernet, and Cellular Wireless Systems
- Server Rack and Network Equipment (Servers, Switches, UPS's) for Energy Management Systems.
- Industrialized PC's, Touch Screens (Magelis), and Human Machine Interfaces (HMI's) with Custom System Graphics.
- Designed to fit any environment – Indoor (Type 1 & 12) & Outdoor (Type 3R & 4) applications

**For additional information and pricing please contact your local PowerLogic sales specialist or PowerLogic Inside Sales Support at 615-287-3535. Equipment pricing and literature available for download on our website at [www.powerlogic.com/products/enclosures](http://www.powerlogic.com/products/enclosures).**

**To better serve you please have the following information on hand when calling.**

- Enclosure type (Indoor or Outdoor) and Environment details (Corrosive or Non-Corrosive)
- Power System Voltage Level and Type (Direct Current (DC) or Alternating Current (AC))
- Digital & Analog Input and Output requirements
- Device Type and Quantity per enclosure
- Ethernet and Serial Communication Requirements
- For Drawout Retrofits, need existing cradle type (i.e. GE, Westinghouse, etc.)

## Reactive Power Compensation and Harmonic Mitigation Solutions

How can reactive power compensation and harmonic mitigation solutions be part of your energy efficiency programs?

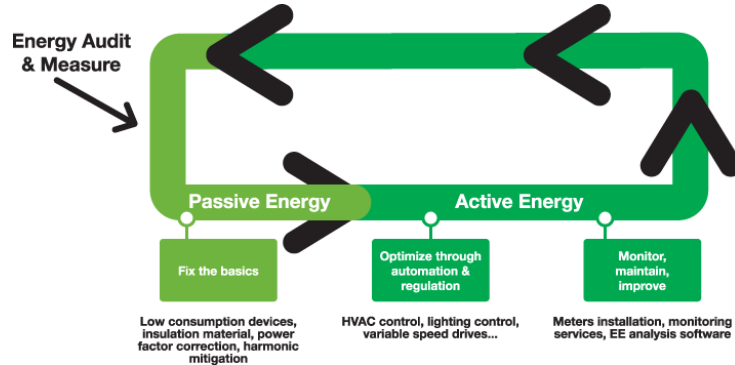

Power factor is a measure of how efficiently you are using electricity. In an electric power system, a load with low power factor draws more current than a load with a high power factor for the same amount of real power transferred. Utility customers with a low power factor could realize an increase or penalty in their electric bill. Over time, these penalties may reach into thousands of dollars, depending upon the utility's rate structure.

Harmonics may disrupt normal operation of other devices and increase operating costs. Symptoms of problematic harmonic levels include overheating of transformers, motors and cables, thermal tripping of protective devices, logic faults of digital devices and drives. Harmonics can cause vibrations and noise in electrical machines (motors, transformers, reactors). The life span of many devices can be reduced by elevated operating temperature.

**As a leader in the field of power quality, Schneider Electric offers the products and services needed to ensure that the most reliable and cost effective solution is applied within your facility. We can help you select the right solution for your application, for greenfield or brownfield projects. Please visit us at <https://www.se.com/us/powerandenergy>.**

Table 4.39: Descriptions, Applications, and Features

Product Description	Application	Product Features
PowerLogic™ PFC Capacitor Bank Detuned	Power Factor Correction	Suited for centralized power factor correction in applications containing harmonic energies that would otherwise damage standard automatic capacitor banks
PowerLogic™ PFC Capacitor Bank Fast	Power Factor Correction	Contains enhanced technology utilizing solid state switching elements that replace standard electromechanical contactors. Provides quicker response to load fluctuations with transient free capacitor switching.
EasyLogic™/PowerLogic™ PFC Capacitor Bank Hybrid	Power Factor Correction and Harmonic Filtering	Provides instantaneous and infinitely variable reactive power compensation for industrial networks containing highly transient or unstable loads, as well as system compensation for large AC motor inrush current. It integrates conventional power factor correction systems and the latest IGBT-based solutions to provide ultra rapid response and infinitely variable KVAR control.
PowerLogic™ PFV+	Power Factor Correction	Provides reactive current compensation for specific and high performance systems. It can eliminate leading or lagging power factor, reduce voltage fluctuations, enhance equipment operating life, and improve system power capacity.
PowerLogic™ PCS+ and PCSn	Power Factor Correction and Harmonic Filtering	It is a flexible, high performance, cost-effective solution to stabilize electrical networks by providing harmonic mitigation, power factor correction, and load balancing. It monitors a distorted electrical signal and determines the frequency and magnitude of harmonics in the signal. It cancels the harmonic content with the dynamic injection of opposing phase current in the distribution system or individual load.

PowerLogic™ PFC Smart Cap Banks

**Your load variation**

Variable or unstable load

Load sensitive to transient switching

**Automatic compensation**

**Network harmonic pollution level**

TDDI	<20%
THD(U)	<7%

Choose **VarSet Detuned**

**480 V - 60 Hz**  
from 50 to 1000 kVAR

**Automatic and transient-free compensation**

TDDI	< 8%
THD(U)	<5%

Choose **VarSet Fast**

**480 V - 60 Hz**  
from 450 kvar to 1200 kvar

**EcoStruxure™**  
Innovation At Every Level

**EcoStruxure™ Power ready**

- Seamless integration thanks to embedded Modbus communication
- Remote equipment follow up & control
- Remote troubleshooting
- Enable analytics & mobile benefits of EcoStruxure™ Power



**Environment**

- Installation: Indoor
- Ambient temperature: 15°F to 114.8°F (-10°C to 46°C)
- Humidity: Up to 95%
- Maximum altitude: 6500 feet (2000 m)

**Standards**

- cCSAus approved
- CSA 22.2 No. 190
- UL810, UL508a

**Environmental Certifications**

- Produced in 14001 certified plants, product environmental profile available

**PowerLogic™ PFC Smart Cap Banks**

The PowerLogic™ PFC Smart Capacitor Bank Detuned automatic capacitor banks provide power factor correction in electrical distribution networks with moderate levels of harmonic content. The series capacitor and reactor combination is tuned below the first dominant harmonic order (usually the 5th). This prevents resonance and harmonic amplification.

**Table 4.40: General Characteristics**

Electrical Characteristics	
Rated voltage	480 V / 60 Hz
Capacitance tolerance	-5%, +10%
Connection type	Three-phase
Power losses	< 6 W / kVAR
Maximum permissible over current	1.3 x In
Maximum permissible over voltage	1.1 x Un, 8 h every 24 h
Enclosure	
Degree of protection	NEMA 1/NEMA 1 Gasket
Color	RAL 7035
Degree of mechanical resistance	IK10
Controller	
PowerLogic™ PFC	PowerLogic™ PFC controller with embedded Modbus communication
Head circuit breaker protection	
Without incoming circuit breaker	<ul style="list-style-type: none"> <li>• Lug connection</li> <li>• LV PFC Bank must be protected by a circuit breaker or by a fused disconnecter from upstream switchboard.</li> </ul>
With incoming circuit breaker	PowerPac™ with rotary handle up to 200 kVAR, toggle switch above 200 kVAR
Step	
Capacitors type	<ul style="list-style-type: none"> <li>• PowerLogic™ PFC Capacitor 575 V for network voltage 480 V</li> <li>• Maximum overcurrent: 1.8 x In</li> <li>• 3 ph overpressure disconnection system</li> <li>• Discharge resistor 50 V - 1mn</li> </ul>
Contactors	Dedicated to capacitor switching
Detuned reactor	<ul style="list-style-type: none"> <li>• PowerLogic™ PFC DR</li> <li>• Overheating protection by thermostat</li> </ul>
Circuit breaker protection	PowerPacT
Temperature control	
Double control	By thermostat and by controller
Communication	
Modbus	RS-485
Installation	
Customer connection	Top Entry
Auxiliary transformer	120 V included - no need for additional supply
CT not included	<ul style="list-style-type: none"> <li>• 5 VA - secondary 1 or 5 A</li> <li>• To be installed upstream of the load and capacitor bank</li> </ul>
GenSet contact	Available for disconnection with generator
Alarm contact	Available for remote warning signal

Options available on request:

- Fixed stages (by controller programming)
- Custom staging ratios
- Bottom cable entry
- Icc level up to 100 kA

**PowerLogic™ PFC**

**Low Voltage Capacitor Bank – Detuned (Network 480V / 60Hz – Tuning order 4.2)**

**Table 4.41: Network voltage 480 V - 60 Hz**

References	Power (kVAR)	Smallest Step	Resolution	Electrical Steps	Physical Steps	Breaking Capacity	Main Circuit Breaker	Enclosure Type	Enclosure Size (H x W x D) mm	Max. Weight (kg/lbs)
<b>With incoming Circuit Breaker</b>										
VA050B40140	050	25	2x25	2	2	65 kA	HLM36100	VAF3P	1300 x 1300 x 400 (51.2 x 51.2 x 15.7) in.	265/585
VA075B40140	075	25	25 + 50	3	2		HLM36125			
VA100B40140	100	25	2x25 + 50	4	3		JLM36175			
VA125B40140	125	25	25 + 2x50	5	3		JLM36200			
VA150B40140	150	25	2x25 + 2x50	6	4		LLM36600U31X			
VA175B40140	175	25	25 + 3x50	7	4		LLM36600U31x			
VA200B40140	200	50	4x50	4	4		LLM36600U31X			
VA250B40140	250	50	50 + 2x100	5	3		LJM36600U31X	VAF1P	2200 x 1000 x 600 (86.6 x 39.4 x 23.6) in.	435 / 959
VA300B40140	300	100	3x100	3	3		LJM36600U31X			460 / 1014
VA350B40140	350	50	50 + 3x100	7	4		PJF36080U31A			500 / 1102
VA400B40140	400	100	4x100	4	4		PJF36100U31A			530 / 1168
VA450B40140	450	50	50 + 4x100	9	5		PJF36100U31A			580 / 1278
VA500B40140	500	100	5x100	5	5		PJF36120U31A			6132200 /
VA550B40140	550	50	50 + 5x100	11	6		PJF36120U31A	750 / 1653		
VA600B40140	600	100	6x100	6	6		PJF36120CU31A	VAF4P	2200 x 1800 x 600 (86.6 x 70.9 x 23.6) in.	775 / 1708
VA650B40140	650	50	50 + 6x100	13	7		PJF36120CU31A			820 / 1807
VA700B40140	700	100	7x100	7	7		RKF36160CU31A			845 / 1862
VA750B40140	750	50	50 + 7x100	15	8		RKF36160CU31A			892 / 1966
VA800B40140	800	100	8x100	8	8		RKF36160CU31A			920 / 2028
VA900B40140	900	100	9x100	9	9		RKF36160CU31A			990 / 2182
VAX00B40140	1000	100	10x100	10	10	RLF36200CU31A	VAF5P	2200 x 2000 x 600 (86.6 x 78.7 x 23.6) in.	1060 / 2336	

References	Power (kVAR)	Smallest Step	Resolution	Electrical Steps	Physical Steps	Short-time Withstand Current	Recommended Upstream Protection	Enclosure Type	Enclosure Size (H x W x D) mm	Max. Weight (kg/lbs)
<b>With Main Lug</b>										
VA050M40140	050	25	2x25	2	2	25 kA/ 3 cycles	HML36100	VAF3P	1300 x 1300 x 400 (51.2 x 51.2 x 15.7) in.	265 / 585
VA075M40140	075	25	25 + 50	3	2		HML36125			
VA100M40140	100	25	2x25 + 50	4	3		JLM36175			
VA125M40140	125	25	25 + 2x50	5	3		JLM36200			
VA150M40140	150	25	2x25 + 2x50	6	4		LLM36600U31X			
VA175M40140	175	25	2 + 3x50	7	4		LLM36600U31X			
VA200M40140	200	50	4x50	4	4	LLM36600U31X				
VA250M40140	250	50	50 + 2x100	5	3	65 kA/ 4 cycles	LJM36600U31X	VAF1P	2200 x 1000 x 600 (86.6 x 39.4 x 23.6) in.	400 / 882
VA300M40140	300	100	3x100	3	3		LJM36600U31X			426 / 939
VA350M40140	350	50	50 + 3x100	7	4		PJF36080U31A			471 / 1038
VA400M40140	400	100	4x100	4	4		PJF36100U31A			498 / 1097
VA450M40140	450	50	50 + 4x100	9	5		PJF36100U31A			543 / 1197
VA500M40140	500	100	5x100	5	5		PJF36120U31A			570 / 1256
VA550M40140	550	50	50 + 5x100	11	6	PJF36120U31A	710 / 1565			
VA600M40140	600	100	6x100	6	6	VAF4P	2200 x 1800 x 600 (86.6 x 39.4 x 23.6) in.	740 / 1631		
VA650M40140	650	50	50 + 6x100	13	7			PJF36120CU31A	785 / 1730	
VA700M40140	700	100	7x100	7	7			RKF36160CU31A	810 / 1785	
VA750M40140	750	50	50 + 7x100	15	8			RKF36160CU31A	857 / 1889	
VA800M40140	800	100	8x100	8	8			RKF36160CU31	883 / 1946	
VA900M40140	900	100	9x100	9	9			RKF36160CU31A	955 / 2105	
VAX00M40140	1000	100	10x100	10	10	RLF36200CU31A	1026 / 2261			



### AccuSine PFV+ Electronic VAR Control

AccuSine PFV+ is a very simple and effective means to eliminate leading or lagging power factor, reduce voltage fluctuations, enhance equipment operating life, and improve system power capacity. AccuSine PFV+ offers many features in one package that others require multiple models to accomplish.

AccuSine PFV+ can help you solve:

- Power factor
- Imbalance (specifically important for motor applications)
- Voltage stability (such as localized photovoltaic networks)
- Flicker
- AccuSine PFV+ integrates with EcoStruxure™ Power's edge control power management and control software and analytics services that scale to your demands and adapt to your needs.

### AccuSine PFV+ Sizing

For proper sizing of AccuSine units, contact the Schneider Electric sales office or visit us at <https://www.se.com/us/powerandenergy>. To expedite the product selection process, please have a single line diagram and/or details of the application including sizes of transformers, non-linear and linear loads, and any existing filters and capacitors.

**Table 4.42: AccuSine PFV+ Selection**

PF Correction and Load Balancing (380-480V models 50/60Hz)							
Rated Current (A)	KVAR Rating @ Voltage	Catalog Number	Rating	Enclosure Style	Cable Entry	Frame	Weight lb (kg)
60 <sup>[1]</sup>	39.5 @ 380 41.6 @ 400 43.1 @ 415 49.9 @ 480	EVCP060D5IP00	IP00 (chassis)	Wall Mount	Bottom	1	194 (88)
		EVCP060D5N2	UL Type 2	Floor Standing	Top or Bottom	2	611 (277)
		EVCP060D5IP31	IP31				642 (291)
		EVCP060D5N12	UL Type 12				
		EVCP060D5IP54	IP54				
120 <sup>[2]</sup>	79.0 @ 380 83.1 @ 400 86.3 @ 415 99.8 @ 480	EVCP120D5IP00	IP00 (chassis)	Wall Mount	Bottom	3	249 (113)
		EVCP120D5N2	UL Type 2	Floor Standing	Top or Bottom	4	615 (279)
		EVCP120D5IP31	IP31				646 (293)
		EVCP120D5N12	UL Type 12				
		EVCP120D5IP54	IP54				
200 <sup>[3]</sup>	131.6 @ 380 138.6 @ 400 143.8 @ 415 166.3 @ 480	EVCP200D5IP00	IP00 (chassis)	Wall Mount	Bottom	5	377 (171)
		EVCP200D5N1	UL Type N1	Floor Standing	Top or Bottom	6	800 (363)
		EVCP200D5N2	UL Type 2				846 (384)
		EVCP200D5IP31	IP31				887 (402)
		EVCP200D5N12	UL Type 12				
EVCP200D5IP54	IP54						
300 <sup>[4]</sup>	197.5 @ 380 207.8 @ 400 215.6 @ 415 249.4 @ 480	EVCP300D5IP00	IP00 (chassis)	Wall Mount	Bottom	7	463 (210)
		EVCP300D5N1	UL Type N1	Floor Standing	Top or Bottom	8	887 (402)
		EVCP300D5N2	UL Type 2				930 (422)
		EVCP300D5IP31	IP31				961 (436)
		EVCP300D5N12	UL Type 12				
EVCP300D5IP54	IP54						

**Table 4.43: PowerLogic™ PCS+ and AccuSine PFV + Exterior Dimensions**

Frame Size	Exterior Dimensions		
	Height in (mm)	Width in (mm)	Depth in (mm)
1	51.18 (1300)	16.57 (421)	13.74 (349)
2	82.68 (2100)	31.50 (800)	19.69 (500)
3	55.12 (1400)	16.57 (421)	15.12 (384)
4	82.68 (2100)	31.50 (800)	19.69 (500)
5	52.09 (1323)	22.91 (582)	17.24 (438)
6	82.68 (2100)	35.43 (900)	23.62 (600)
7	61.42 (1560)	22.91 (582)	17.24 (438)
8	82.68 (2100)	35.43 (900)	23.62 (600)
9	82.68 (2100)	51.18 (1300)	19.69 (500)
10	82.68 (2100)	55.12 (1400)	23.62 (600)
11	78.74 (2000)	31.50 (800)	23.62 (600)

### AccuSine+ Wall Mount Conversion Kit

- Converts IP00 (UL Type Open) to IP20 (UL Type 1) wall mounted enclosed assemblies.
- Includes HMI mounting plate and cable entry enclosure for mounting on the bottom of the IP00 assemblies.

**Table 4.44: AccuSine+ Wall Mount Kits**

Wall Mount Kit Reference	Assembled Dimensions — IP20				IP20 Assembly Weight lb (kg)	Cable Entry Enclosure Weight lb (kg)
	Unit Rating (A)	Height in (mm)	Width in (mm)	Depth in (mm)		
PCSPWMKIT60A	60	60.24 (1530)	16.57 (421)	13.7 (349)	214.51 (97.3)	19.18 (8.7)
PCSPWMKIT120A	120	64.17 (1630)	16.57 (421)	15.12 (384)	269 (122)	20.5 (9.3)
PCSPWMKIT300A	200	64.64 (1642)	22.64 (575)	17.13 (435)	396.83 (180)	19 (8.6)
PCSPWMKIT300A	300	74 (1882)	22.64 (575)	17.13 (435)	481.93 (218.6)	19 (8.6)

[1] 60 A IP20/UL Type 1 configuration requires ordering two items: EVCP060D5IP00 and PCSPWMKIT60A; adds 9.12 in (232 mm) to length and 19.18 lb (8.7 kg).  
 [2] 120 A IP20/UL Type 1 configuration requires ordering two items: EVCP120D5IP00 and PCSPWMKIT120A; adds 9.13 in (232 mm) to length and 20.5 lb (9.3 kg).  
 [3] 200 A IP20/UL Type 1 configuration requires ordering two items: EVCP200D5IP00 and PCSPWMKIT300A; adds 10.75 in (273 mm) to length and 19 lb (8.6 kg).  
 [4] 300 A IP20/UL Type 1 configuration requires ordering two items: EVCP300D5IP00 and PCSPWMKIT300A; adds 10.75 in (273 mm) to length and 19 lb 8.6 kg).

**AccuSine Current Transformers**

**Split-Core Design**

**Construction**

Directional silicon steel is used for the flexible core. Secondary windings are of copper. Unit is encapsulated in silicone rubber, which protects against moisture, dirt, oil, and corona.

**Table 4.45: Specifications**

Description		Specification
Insulation Level		0.72 kV BIL 10 kV Full Wave
Frequency		50-400 Hz
Thermal Factor		1.25 at 30 °C; 1.0 at 55 °C
Operating Temp Range		-45 °C to +55 °C
Altitude		Up to 4000 Meters
Accuracy (Primary rating)	200 through 300	4 %
	400 through 500	3 %
	600 through 800	2 %
	1000 through 6000	1 %
Secondary Leads		3.65 m with spade connectors
Color		Transformer (red) - Leads (yellow)
Remains flexible from -45° to +200 °C		



Twisting motion opens to CT diameter of round CT and smaller distance of rectangular CT.  
NOTE: Open split-core with a twisting motion only.

**Table 4.46: Round Split-Core Design**

Reference Number by Secondary Current		Maximum load (A)	Inside diameter (ID) in (mm) - A	Burden Capacity (Ω)		Weight lb (kg)
5 A	1 A			5 A	1 A	
PCSPCTFCL50054	PCSPCTFCL50014	500	4 (101.6)	0.120	2.0	3.35 (1.6)
PCSPCTFCL100054	PCSPCTFCL100014	1000	4 (101.6)	0.200	10.0	3.53 (1.6)
PCSPCTFCL150054	—	1500	4 (101.6)	0.375	15.0	3.53 (1.6)
PCSPCTFCL160054	—	1600	4 (101.6)	0.375	15.0	3.53 (1.6)
PCSPCTFCL50056	—	500	6 (152.4)	0.120	2.0	4.19 (1.9)
—	PCSPCTFCL100016	1000	6 (152.4)	0.200	10.0	4.19 (1.9)
PCSPCTFCL120056	—	1200	6 (152.4)	0.200	15.0	4.19 (1.9)
PCSPCTFCL150056	PCSPCTFCL150016	1500	6 (152.4)	0.375	15.0	4.19 (1.9)
PCSPCTFCL200056	PCSPCTFCL200016	2000	6 (152.4)	1.000	18.0	4.19 (1.9)
PCSPCTFCL250056	—	2500	6 (152.4)	1.400	20.0	4.19 (1.9)
PCSPCTFCL300056	—	3000	6 (152.4)	1.800	20.0	4.19 (1.9)
—	PCSPCTFCL200018	2000	8 (203.2)	1.000	18.0	5.51 (2.5)
PCSPCTFCL250058	—	2500	8 (203.2)	1.400	20.0	5.51 (2.5)
PCSPCTFCL400058	—	4000	8 (203.2)	1.800	20.0	5.51 (2.5)
PCSPCTFCL500058	—	5000	8 (203.2)	1.800	20.0	5.51 (2.5)
PCSPCTFCL2500511	—	2500	11 (279.4)	1.400	20.0	7.5 (3.4)



Twisting motion opens to CT diameter of round CT and smaller distance of rectangular CT.  
NOTE: Open split-core with a twisting motion only.

**Table 4.47: Rectangular Split-Core Design**

Reference Number by Secondary Current		Maximum load (A)	Inside diameter (ID) in (mm)		Burden Capacity (Ω)		Weight lb (kg)
5 A	1 A		A	B	5 Amp	1 Amp	
PCSPCTFCL5005R	PCSPCTFCL5001R	500	2.74 (69.8)	6.6 (168.2)	0.12	2.0	4.19 (1.9)
PCSPCTFCL10005R	PCSPCTFCL10001R	1000	2.74 (69.8)	6.6 (168.2)	0.2	10.0	4.19 (1.9)
PCSPCTFCL12005R	PCSPCTFCL12001R	1200	2.74 (69.8)	6.6 (168.2)	0.2	15.0	4.19 (1.9)
PCSPCTFCL15005R	PCSPCTFCL15001R	1500	2.74 (69.8)	6.6 (168.2)	0.375	15.0	4.19 (1.9)
PCSPCTFCL16005R	PCSPCTFCL16001R	1600	2.74 (69.8)	6.6 (168.2)	0.375	15.0	4.19 (1.9)
PCSPCTFCL20005R	—	2000	2.74 (69.8)	6.6 (168.2)	1	18.0	4.19 (1.9)
PCSPCTFCL30005R	—	3000	2.74 (69.8)	6.6 (168.2)	1.8	20.0	4.19 (1.9)
PCSPCTFCL25005R411	PCSPCTFCL25001R411	2500	4 (101.6)	11 (279.4)	1.4	20.0	6.17 (2.8)
PCSPCTFCL30005R411	—	3000	4 (101.6)	11 (279.4)	1.8	20.0	6.17 (2.8)
PCSPCTFCL40005R411	—	4000	4 (101.6)	11 (279.4)	1.8	20.0	6.17 (2.8)
PCSPCTFCL50005R411	—	5000	4 (101.6)	11 (279.4)	1.8	20.0	6.17 (2.8)

**Round Solid-Core Design**

**Table 4.48: Specifications**

Description	Specification
Frequency	50-400 Hz
Class	0.6 kV, 10 kV BIL Full Wave
Flexible Leads	UL1015, 105 °C; CSA approved; 16 AWG (1.31 mm <sup>2</sup> ), 609.6 mm
Weight	Approximately 0.68 kg
Accuracy	1 %

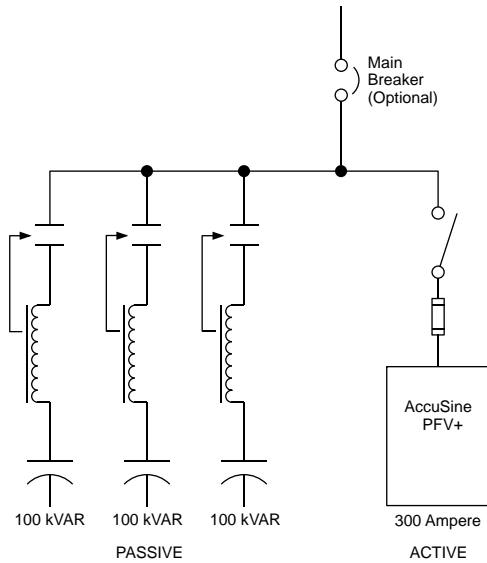

**Table 4.49: Round Solid-Core Design**

Reference Number by secondary current		Maximum load (Amps)	Burden Capacity (Ω)	
5 Amps	1 Amp		5 Amp	1 Amp
—	PCSPCT7RL2011	200	0.5	5.0
PCSPCT7RL3015	PCSPCT7RL3011	300	0.5	5.0
PCSPCT7RL4015	PCSPCT7RL4011	400	0.6	7.5
PCSPCT7RL5015	PCSPCT7RL5011	500	1.0	10.0
PCSPCT7RL6015	PCSPCT7RL6011	600	1.2	12.5
PCSPCT7RL7515	PCSPCT7RL7511	750	1.2	12.5
PCSPCT7RL8015	PCSPCT7RL8011	800	1.4	20.0
PCSPCT7RL1025	PCSPCT7RL1021	1000	1.4	25.0
PCSPCT7RL1225	PCSPCT7RL1221	1200	1.4	15.0
PCSPCT7RL1525	PCSPCT7RL1521	1500	1.6	20.0
PCSPCT7RL1625	PCSPCT7RL1621	1600	2.0	25.0

## VarSet Hybrid

Rebranded!



Topology (Typical)

### Main Features:

- Ultra fast reactive current compensation for transient or cyclical loads
- Infinitely variable control
- Instantaneous response for inrush support
- Independently compensates each phase
- Heavy duty dry capacitors provide no risk of fluid leakage, no environmental pollution, and no need for drip pans
- Detuned iron core reactors prevent resonance
- IGBT based power electronic technology
- Stepless power factor correction
- Best-in-class harmonic cancellation up to 50th harmonic and less than 3% THDi
- Energy efficient 3-level IGBT inverter technology
- All major components from Schneider Electric

Power quality issues like harmonics and reactive power can cause problems including equipment damage and reduced reliability. In industrial networks, highly fluctuating loads like spot welders can cause voltage fluctuations and/or flicker that can lead to process malfunctions. The detrimental effects are increased operating expenses, expensive downtime, overheating equipment or poor quality on manufactured parts.

VarSet Hybrid systems provide instantaneous and infinitely variable power factor correction for industrial networks containing highly transient or unstable loads, as well as system compensation for large AC motor inrush current.

The VarSet Hybrid system integrates conventional power factor correction systems and the latest IGBT-based solutions to provide ultra rapid response and infinitely variable kVAR control never before seen in a power factor correction product. Specifically designed for the instantaneous support required by welding equipment, the VarSet Hybrid eliminates voltage sags and voltage flicker while increasing system capacity, providing energy savings and improving weld quality. It also provides current inrush support for applications such as large horsepower motor starting. The VarSet Hybrid is comprised of a Detuned Capacitor Bank with either an Active Harmonic Filter or an Electronic Var Compensator.

Active Harmonic Filters (AHF) are static power electronic products that employ digital logic and IGBT semiconductors to synthesize a current waveform that is injected into the electrical network to cancel harmonic currents caused by nonlinear loads. AHF employ current transformers to measure the load current to determine the content of harmonic current present. By injecting the synthesized current, network harmonic currents are greatly mitigated, thus reducing the heating effects of harmonic current and reducing voltage distortion.

AHF also have the ability to correct for poor displacement power factor (DPF) and provide for mains current balancing. DPF correction can be provided for either leading (capacitive) or lagging (inductive) loads. Mains current balancing is achieved by measuring the negative sequence current present and injecting the inverse negative sequence current to balance the current for the upstream network.

An Electronic Var Compensator (EVC) is a power electronic device consisting of insulated gate bipolar transistors (IGBT) that switch into the AC lines to modulate the output to correct the displaced reactive current (leading or lagging) and balance the current for the power source (also known as negative sequence current).

Detuned Capacitor Banks are automatic capacitor banks made of several capacitor steps controlled by a power factor (PF) controller. They are able to adjust PF to any value between 0.8 lagging and unity. When the PF differs from the target setting for more than 1 second, the capacitor switching modules switch stages as needed to bring the PF as close as possible to the target PF. Switching can be accomplished by electro-mechanical contactors or solid state switches.

The VarSet Hybrid is a custom solution that is engineered to order. Your local Schneider Electric representative can help you select the correct hybrid solution for your specific needs. To learn more, visit us at <https://www.se.com/us/powerandenergy>.



### AccuSine PCS+ Active Harmonic Filter (AHF)

AccuSine PCS+ Active Harmonic Filter (AHF) injects harmonic current to cancel harmonic current in the electrical distribution system. This reduced harmonic level results in improved electrical network reliability and reduced operating cost. AccuSine PCS+ is simple to size, install, set up and operate. In addition, AccuSine PCS+ eliminates the complex harmonic compliance limit calculations and removes nuisance harmonics from the electrical network.

**The Problem:** Power electronic devices that have rapid and frequent load variations have become abundant today due to their many process control related and energy saving benefits. However, they also bring a few major drawbacks to electrical distribution systems; harmonics and rapid change of reactive power requirement. Harmonics may disrupt normal operation of other devices and increase operating costs. Symptoms of problematic harmonic levels include overheating of transformers, motors, drives, cables, thermal tripping of protective devices and logic faults of digital devices. In addition, the life span of many devices can be reduced by elevated operating temperature.

**The Solution:** The AccuSine PCS+ AHF provides the simplest and most effective means to mitigate harmonics, to reduce process related voltage fluctuations. The AccuSine PCS+ AHF actively injects opposite harmonics current on the source side of the load. In addition, it:

- Decreases harmonic related overheating of cables, switchgear and transformers
- Reduces downtime caused by nuisance thermal tripping of protective devices
- Increases electrical network reliability and reduces operating costs
- Corrects to the 51st harmonic, reduce harmonics level to meet IEEE 519, IEC 61000 3-4, and UK G5/4-1 standards.
- Compensates entire network or specific loads depending on installation point

**Standard Features:**

- Real-time dynamic current injection for harmonic cancellation and VAR compensation (lead or lag power factor)
- Load balancing capability
- Parallel connection allows for easy retrofit and installation of multiple units for large networks
- Response to load fluctuations within 2 cycles for harmonics, 1/4 cycle for power factor or load balancing
- Full color touch screen HMI (Human Machine Interface)
- UL Type 1, UL Type 2, UL Type 12, IP31, and IP54 enclosures
- Seismic rated per ICC IBC and ASCE 7
- UL, CE, ABS, and CSA certified
- AccuSine PCS+ integrates with EcoStruxure™ Power's edge control power management and control software and analytics services that scale to your demands and adapt to your needs.

**AccuSine PCS+ Sizing:** For proper sizing of AccuSine units, contact your local Schneider Electric representative or visit us at <https://www.se.com/us/powerandenergy>. To expedite the product selection process, please have a single line diagram and/or details of the application including sizes of transformers, non-linear and linear loads, and any existing filters and capacitors.

**Table 4.50: PCS+ Active Harmonic Filter Selection**

AccuSine PCS+ (380–480 V, 50/60 Hz)							
Rated Current	KVAR Rating @ Voltage	Catalog Number	Enclosure			Frame	Weight lb (kg)
			Rating	Style	Cable Entry		
60 <sup>[5]</sup>	39.5 @ 380 41.6 @ 400 43.1 @ 415 49.9 @ 480	PCSP060D5IP00	IP00 (chassis)	Wall Mount	Bottom	1	194 (88)
		PCSP060D5N2	UL Type 2	Floor Standing	Top or Bottom	2	611 (277)
		PCSP060D5IP31	IP31				
		PCSP060D5N12	UL Type 12				
		PCSP060D5IP54	IP54	Wall Mount	Bottom	3	249 (113)
PCSP120D5IP00	IP00 (chassis)						
120 <sup>[6]</sup>	79.0 @ 380 83.1 @ 400 86.3 @ 415 99.8 @ 480	PCSP120D5N2	UL Type 2	Floor Standing	Top or Bottom	4	615 (279)
		PCSCP120D5IP31	IP31				
		PCSP120D5N12	UL Type 12				
		PCSP120D5IP54	IP54	Wall Mount	Bottom	5	377 (171)
		PCSP200D5IP00	IP00 (chassis)				
200 <sup>[7]</sup>	131.6 @ 380 138.6 @ 400 143.8 @ 415 166.3 @ 480	PCSP200D5N1	UL Type N1	Floor Standing	Top or Bottom	6	846 (384)
		PCSP200D5N2	UL Type 2				
		PCSP200D5IP31	IP31				
		PCSP200D5N12	UL Type 12	Wall Mount	Bottom	7	463 (210)
		PCSP200D5IP54	IP54				
PCSP300D5IP00	IP00 (chassis)	Wall Mount	Bottom	11	887 (402)		
PCSP300D5N1	UL Type N1						
300 <sup>[8]</sup>	197.5 @ 380 207.8 @ 400 215.6 @ 415 249.4 @ 480	PCSP300D5N2	UL Type 2	Floor Standing	Top or Bottom	8	930 (422)
		PCSP300D5IP31	IP31				
		PCSP300D5N12	UL Type 12				
		PCSP300D5IP54	IP54	Wall Mount	Bottom	11	887 (402)
		PCSP300D5IP00	IP00 (chassis)				

[5] 60 A IP20/UL Type 1 configuration requires ordering two items: PCSP060D5IP00 and PCSPWMKIT60A; adds 9.13 in (232 mm) to IP00 length and 19.18 lb (8.7 kg).

[6] 120 A IP20/UL Type 1 configuration requires ordering two items: PCSP120D5IP00 and PCSPWMKIT120A; adds 9.13 in (232 mm) to IP00 length and 20.5 lb (9.3 kg).

[7] 200 A IP20/UL Type 1 configuration requires ordering two items: PCSP200D5IP00 and PCSPWMKIT300A; adds 10.75 in (273 mm) to IP00 length and 19 lb (8.6 kg).

[8] 300 A IP20/UL Type 1 configuration requires ordering two items: PCSP300D5IP00 and PCSPWMKIT300A; adds 10.75 in (273 mm) to IP00 length and 19 lb (8.6 kg).

New!

### AccuSine PCSn Active Harmonic Filter (AHF)

Part of the AccuSine+ family, the AccuSine PCSn is the ideal solution for harmonic mitigation in commercial buildings, light industry, and other less-harsh environments. In addition to 3-phase mitigation, AccuSine PCSn can compensate for neutral harmonic currents, typically present in building and commercial environments where single-phase non-linear loads are present.



- Configurable: One solution for multiple needs, AccuSine PCSn can be configured for Harmonic Mitigation + PF Improvement + Mains Load Balancing.
- Best-in-class performance to reduce THDi < 3%: Built on award winning AccuSine+ technology, this guarantees a harmonic-free system, improving system reliability, and increasing operational efficiency and uptime.
- Power Factor (cosφ), THDi, and THDv setpoint features provide system-level visibility and control, ensuring that you comply with utility code, and that your system is running at optimal efficiency.
- Harmonic mitigation eliminates harmonic current in the neutral. In a 3-phase system, unbalanced loads introduce a current in the neutral. Applying the mains load balancing function reduces the neutral current to zero, resulting in a perfectly stable system.
- Smart commissioning: Automatic CT polarity detection and correction, intelligent paralleling algorithm saves you time through unit self-identification, system view allows commissioning of the entire system from any one unit.
- Simple Scalability: Add more AccuSine modules as your harmonic mitigation needs change with your load requirements, easily integrating new modules through intelligent paralleling capabilities.
- With conventional power quality solutions you need high capital investment, incur large operating costs and may find it difficult to comply with IEEE 519 guidelines. The PCSn is the perfect alternative to conventional solutions like Harmonic Mitigation Transformers, Isolation Transformers, Passive Filters, Dual winding transformers.
- AccuSine PCSn integrates with EcoStruxure™ Power's edge control power management and control software and analytics services that scale to your demands and adapt to your needs.
- CE and cULus certified.

**AccuSine PCSn Sizing:** For proper sizing of AccuSine units, contact your local Schneider Electric representative or visit us at <https://www.se.com/us/powerandenergy>. To expedite the product selection process, please have a single line diagram and/or details of the application including sizes of transformers, non-linear and linear loads, and any existing filters and capacitors.

Table 4.51: AccuSine PCSn Commercial References

AccuSine PCSn 208–415 V, 50/60 Hz, UL Type 1, Wall Mount								
Catalog Number	Rated Current (A)	Neutral Rated Current (A)	Rated kVAR @ 208 V	Unit Type	Breaker Rating Required (A) <sup>[9]</sup>	Exterior Dimensions (H x W x D)	Mass	Cable Entry
PCSN020Y4N1	20 A	60 A	7.02	Main	25 A	57 in x 17.5 in x 10.5 in	163 lb	Bottom
PCSN030Y4N1	30 A	90 A	10.8	Main	40 A		163 lb	
PCSN050Y4N1	50 A	150 A	18.0	Main	63 A		163 lb	
PCSN060Y4N1	60 A	180 A	21.6	Main	80 A		196 lb	
PCSN060Y4N1E	60 A	180 A	21.6	Expansion	80 A		196 lb	
							196 lb	

**NOTE:** All dimensions are indicative. Please refer to the dimensions in the installation manual and engineering drawings for design purposes.

[9] Applicable for TN-C, TN-S, TN-C-S grounding systems. For detailed information please refer to the AccuSine PCSn installation manual.

*New!*

### PowerLogic™ AccuSine™ EVC+

Unlock the potential with true energy efficiency! PowerLogic AccuSine EVC+ is fast, stepless, modular, and can be wall-mounted. It can be configured for Power Factor Correction and Harmonic Mitigation, among others uses.



#### Electrical networks are changing dramatically

Tomorrow's power quality problems cannot be solved with yesterday's solutions. Traditional, capacitor-based, power factor correction solutions are not designed to support our customers' ambition towards Electricity 4.0 and Net Zero with fast-changing loads, hypersensitive electronics and distributed energy resources (DER).

EVC+ provides stepless VAR compensation to achieve perfect Power Factor (within 1 kVAR) and responds to load changes within 25µs.

#### Not your typical power factor correction system

In addition to providing superior performance for power factor correction for leading and lagging VAR control, PowerLogic AccuSine EVC+ can mitigate harmonics currents commonly seen in commercial and industrial applications (5th, 7th, 11th, and 13th).

Multiple units can be paralleled for faster commissioning (configure entire system from one unit) and to provide more VAR compensation.

#### Improve energy efficiency, increase savings immediately

Onboard wizard, automatic CT calibration for simple commissioning. Modular design to help ensure uptime and equipment reliability. On-target, stepless correction that complies with utility regulations.

#### Thermal reliability

- Dynamic cooling for optimized efficiency
- Withstand up to +122 °F without derating
- Maximum ambient temperature +127 °F

#### Reliable and robust

- Connectivity-ready
- Cybersecure
- Seismically tested to 2.47g
- Built-in EMC filter
- THDv ≤ 15% withstand

#### Certifications and Compliance

- US and CSA
- DNV and ABS
- HCAI (OSHPD)

4

POWER MONITORING AND CONTROL

Table 4.52: Electronic VAR Compensator / Static VAR Generator

Network Rated Voltage	Installation	Standards	Certifications	Enclosure Mounting	Enclosure Degree of Protection	Reactive Power Ratings (50/60 Hz)	Catalog Number
208–480 Vac	Indoor	UL 508 CSA C22.2 No 14 ISO 9001 IEEE 519-2014 IEC 62477-1 IEC 61439-1	CE cULus RCM	Tray mounted	IP00	75 kvar 380 Vac 75 kvar 480 Vac 47 kvar 240 Vac 41 kvar 208 Vac	EVC075D5CH00
						100 kvar 380 Vac 100 kvar 480 Vac 63 kvar 240 Vac 55 kvar 208 Vac	EVC100D5CH00
				Wall Mounted	UL Type 1	75 kvar 380 Vac 75 kvar 480 Vac 47 kvar 240 Vac 41 kvar 208 Vac	EVC075D5W01
						100 kvar 380 Vac 100 kvar 480 Vac 63 kvar 240 Vac 55 kvar 208 Vac	EVC100D5W01
			Wall Mounted	UL Type 2	75 kvar 380 Vac 75 kvar 480 Vac 47 kvar 240 Vac 41 kvar 208 Vac	EVC075D5W02	
					100 kvar 380 Vac 100 kvar 480 Vac 63 kvar 240 Vac 55 kvar 208 Vac	EVC100D5W02	
			Tray mounted	IP00	100 kvar 380 Vac 100 kvar 480 Vac 63 kvar 240 Vac 55 kvar 208 Vac	EVC100D5CH00	
					Wall Mounted	IP21	100 kvar 380 Vac 100 kvar 480 Vac 63 kvar 240 Vac 55 kvar 208 Vac
			CE cULus RCM DNV ABS				

Visit [PowerLogic AccuSine EVC Plus](http://www.se.com/us) online at [www.se.com/us](http://www.se.com/us) for the most current product listings and documentation.