

PointMax I/O System Specifications

Bulletin 5034

Topic

[PointMax I/O System Overview on page 8](#)

[EtherNet/IP Adapter on page 11](#)

[Mounting Bases on page 18](#)

[Digital I/O Modules on page 23](#)

[Safety Digital I/O Modules on page 61](#)

[Analog I/O Modules on page 72](#)

[Specialty I/O Module on page 109](#)

[Expansion Power on page 134](#)

[Power Terminal Module on page 139](#)

[Removable Terminal Blocks on page 143](#)

[Accessories on page 152](#)

[Additional Resources on page 157](#)

Rockwell Automation recognizes that some of the terms that are currently used in our industry and in this publication are not in alignment with the movement toward inclusive language in technology. We are proactively collaborating with industry peers to find alternatives to such terms and making changes to our products and content. Please excuse the use of such terms in our content while we implement these changes.

Summary of Changes

This publication contains the following new or updated information. This list includes substantive updates only and is not intended to reflect all changes. Translated versions are not always available for each revision.

Topic

Updated the following:

- [Table 25: Technical Specifications - 5034-UB8F, 5034-UB8FXT - Input on page 54](#)
 - [Table 26: Technical Specifications - 5034-UB8F, 5034-UB8FXT - Output on page 55](#)
 - [Table 63: Technical Specifications - 5034-ENC, 5034-ENCXT - Digital Output on page 127](#)
-

Catalog Numbers

This publication is applicable to these modules and accessories:

EtherNet/IP Adapter	5034-AENTR, 5034-AENTRXT
Mounting Base	5034-MB, 5034-MBXT, 5034-MBSA, 5034-MBSAXT
Digital I/O Module	5034-IB16, 5034-IB16XT, 5034-IB8, 5034-IB8XT, 5034-OB16, 5034-OB16XT, 5034-OB8, 5034-OB8XT, 5034-OB4, 5034-OB4XT, 5034-OW4I, 5034-OW4IXT, 5034-UB8, 5034-UB8XT, 5034-UB8F, 5034-UB8FXT
Safety Digital I/O Module	5034-IB8S, 5034-IB8SXT, 5034-OB8S, 5034-OB8SXT
Analog I/O Module	5034-IF8C, 5034-IF8CXT, 5034-IF8V, 5034-IF8VXT, 5034-IF4, 5034-IF4XT, 5034-IRT4I, 5034-IRT4IXT, 5034-OF4, 5034-OF4XT, 5034-IF4IH, 5034-IF4IHXT, 5034-OF4IH, 5034-OF4IHXT
Specialty I/O Module	5034-IOL4, 5034-IOL4XT, 5034-SERIAL, 5034-SERIALXT, 5034-ENC, 5034-ENCXT
Expansion Power	5034-EXP, 5034-EXPXT
Potential Terminal Module	5034-MBPTM, 5034-MBPTMXT
Removable Terminal Block for Modules	5034-RTB18, 5034-RTB18S, 5034-RTB24S, 5034-RTBT, 5034-RTBTS
Removable Terminal Block Accessories	5034-RTB2, 5034-RTB2S, 5034-RTB6, 5034-RTB6S
Accessories	5034-AENRTB-QTY5, 5034-AENRTBS-QTY5, 5034-RTB2-QTY5, 5034-RTB2S-QTY5, 5034-SHIELD-QTY5, 5034-ECR-QTY5, 5034-WIREHLD-QTY5, 5034-CM18-IB16-QTY5, 5034-CM18-OB16-QTY5, 5034-CM18-IB8-QTY5, 5034-CM18-IB8S-QTY5, 5034-CM18-OB8-QTY5, 5034-CM18-OB4-QTY5, 5034-CM18-UB8-QTY5, 5034-CM18-IF4IH-QTY5, 5034-CM18-OF4IH-QTY5, 5034-CM18-IF4-QTY5, 5034-CM18-OF4-QTY5, 5034-CM18-IF8C-QTY5, 5034-CM18-IF8V-QTY5, 5034-CM18-IRT4I-QTY5, 5034-CM18-OW4I-QTY5, 5034-CM18-IOL4-QTY5, 5034-CM18-SERIAL-QTY5, 5034-CM18-ENC-QTY5, 5034-CM18-MBPTM-QTY5, 5034-CM24-IF8-QTY5, 5034-CM24-IB8-QTY5, 5034-CM24-UB8-QTY5, 5034-KEY-QTY5, 5034-N

Terminology

This table defines the terms that are used in this publication.

Table 1. Terminology

Acronym	Full Term	Definition
BP	Backplane Power	Power that is generated from module power by the adapter and expansion power, and supplied to the I/O system through the backplane.
CIP™	Common Industrial Protocol	An industrial communication protocol that is used by Logix 5000® based automation systems on EtherNet/IP™, ControlNet®, and DeviceNet® communication networks.
CIP Sync™	Common Industrial Protocol Synchronization	CIP Sync provides the increased control coordination needed for control applications where absolute time synchronization is vital to achieve real-time synchronization between distributed intelligent devices and systems.
CJC	Cold Junction Compensator	A device that is used in thermocouple measurements to help obtain accurate temperature readings at the hot junction.
DAC	Digital to Analog Converter	A device converts digital signals into analog signals, enabling seamless communication between digital devices and analog systems.
DCE	Data Communications Equipment	A device that facilitates data transmission over a network.
DTE	Data Terminal Equipment	A device that serves as a communication endpoint in a network.
HART	Highway Addressable Remote Transducer	A protocol that enables both analog and digital communication over the same wiring, including device diagnostic and status information.
HSC	High-speed Counter	A device that is used to count input signals at a rapid rate.
MB	Mounting Base	A device that provides data and power connections from the backplane to the installed module.
MP	Module Power	Power that is supplied to the adapter and expansion power.
MSB	Most Significant Bit	The bit that has the largest value in a multi-bit binary number.
NFC	Near Field Communication	A short-range wireless technology that enables communication between two electronic devices over a distance of 4 cm (1.6 in.) or less.
ODVA	Open DeviceNet Vendor Association	A nonprofit association of vendors that are established for the promotion of CIP networks.
PL	Performance Level	ISO 13849-1 safety rating
RIUP	Removal and Insertion Under Power	A feature that enables the device to be connected and disconnected from the system without having to remove power from the system.
RPI	Requested Packet Interval	Time interval (usually in milliseconds) that users are requesting their data be exchanged at
RTB	Removable Terminal Block	A component that is used for wiring field devices to.
RTD	Resistance Temperature Detector	A type of sensor whose resistances change as its temperature changes.

Table 1. Terminology (continued)

Acronym	Full Term	Definition
SA	Sensor Actuator	A term that is used to describe field-side devices.
SELV	Safety Extra Low Voltage	An electrical system where the voltage level is considered safe under normal or fault conditions, as defined in the EN and IEC standards.
SIO	Standard Input/Output	Describes the function of a port on an IO-Link master device.
SSI	Serial Synchronous Interface	A serial communication standard for transmitting data between a leader device and a follower device.
SSV	Sensor Source Voltage	Voltage that is supplied to a sensor.
XT	Harsh Environment	These modules have additional conformal coating and design considerations that add a greater degree of protection when exposed to harsh, corrosive environments.
VCL	Voltage Clamp Low	The low threshold for limiting the voltage level.

Components and Accessories Compatibility

The following table lists the I/O modules and which MB, RTB, and color markers they are compatible with.

Table 2. Components and Accessories Compatibility

Catalog Number	MB Supported	RTB Supported	Color Marker (5034-CM18)	Color Marker (5034-CM24)
5034-IB16	5034-MB, 5034-MBSA	5034-RTB18, 5034-RTB18S	5034-CM18-IB16-QTY5	-
5034-IB16XT	5034-MBXT, 5034-MBSAXT			
5034-IB8	5034-MB, 5034-MBSA	5034-RTB18, 5034-RTB18S, 5034-RTB24S	5034-CM18-IB8-QTY5	5034-CM24-IB8-QTY5
5034-IB8XT	5034-MBXT, 5034-MBSAXT			
5034-OB16	5034-MB, 5034-MBSA	5034-RTB18, 5034-RTB18S	5034-CM18-OB16-QTY5	-
5034-OB16XT	5034-MBXT, 5034-MBSAXT			
5034-OB8	5034-MB, 5034-MBSA	5034-RTB18, 5034-RTB18S	5034-CM18-OB8-QTY5	-
5034-OB8XT	5034-MBXT, 5034-MBSAXT			
5034-OB4	5034-MB, 5034-MBSA	5034-RTB18, 5034-RTB18S	5034-CM18-OB4-QTY5	-
5034-OB4XT	5034-MBXT, 5034-MBSAXT			
5034-OW4I	5034-MB, 5034-MBSA	5034-RTB18, 5034-RTB18S	5034-CM18-OW4I-QTY5	-
5034-OW4IXT	5034-MBXT, 5034-MBSAXT			
5034-UB8	5034-MB, 5034-MBSA	5034-RTB18, 5034-RTB18S, 5034-RTB24S	5034-CM18-UB8-QTY5	5034-CM24-UB8-QTY5
5034-UB8XT	5034-MBXT, 5034-MBSAXT			
5034-UB8F	5034-MB, 5034-MBSA	5034-RTB18, 5034-RTB18S, 5034-RTB24S	5034-CM18-UB8-QTY5	5034-CM24-UB8-QTY5
5034-UB8FXT	5034-MBXT, 5034-MBSAXT			
5034-IB8S	5034-MB, 5034-MBSA	5034-RTB18, 5034-RTB18S	5034-CM18-IB8S-QTY5	-
5034-IB8SXT	5034-MBXT, 5034-MBSAXT			
5034-OB8S	5034-MB, 5034-MBSA	5034-RTB18, 5034-RTB18S	5034-CM18-OB8-QTY5	-
5034-OB8SXT	5034-MBXT, 5034-MBSAXT			
5034-IF8C	5034-MB, 5034-MBSA	5034-RTB18, 5034-RTB18S, 5034-RTB24S	5034-CM18-IF8C-QTY5	5034-CM24-IF8C-QTY5
5034-IF8CXT	5034-MBXT, 5034-MBSAXT			

Table 2. Components and Accessories Compatibility (continued)

Catalog Number	MB Supported	RTB Supported	Color Marker (5034-CM18)	Color Marker (5034-CM24)
5034-IF8V	5034-MB, 5034-MBSA	5034-RTB18, 5034-RTB18S, 5034-RTB24S	5034-CM18-IF8V-QTY5	5034-CM24-IF8V-QTY5
5034-IF8VXT	5034-MBXT, 5034-MBSAXT			
5034-IF4	5034-MB, 5034-MBSA	5034-RTB18, 5034-RTB18S	5034-CM18-IF4-QTY5	-
5034-IF4XT	5034-MBXT, 5034-MBSAXT			
5034-IF4IH	5034-MB, 5034-MBSA	5034-RTB18, 5034-RTB18S	CM18-IF4IH-QTY5	-
5034-IF4IHXT	5034-MBXT, 5034-MBSAXT			
5034-IRT4I	5034-MB, 5034-MBSA	5034-RTB18, 5034-RTB18S, 5034-RTBT, 5034-RTBTS	5034-CM18-IRT4I-QTY5	-
5034-IRT4IXT	5034-MBXT, 5034-MBSAXT			
5034-OF4	5034-MB, 5034-MBSA	5034-RTB18, 5034-RTB18S	5034-CM18-OF4-QTY5	-
5034-OF4XT	5034-MBXT, 5034-MBSAXT			
5034-OF4IH	5034-MB, 5034-MBSA	5034-RTB18, 5034-RTB18S	5034-CM18-OF4IH-QTY5	-
5034-OF4IHXT	5034-MBXT, 5034-MBSAXT			
5034-IOL4	5034-MB, 5034-MBSA	5034-RTB18, 5034-RTB18S	5034-CM18-IOL4-QTY5	-
5034-IOL4XT	5034-MBXT, 5034-MBSAXT			
5034-SERIAL	5034-MB, 5034-MBSA	5034-RTB18, 5034-RTB18S	5034-CM18-SERIAL-QTY5	-
5034-SERIAL	5034-MBXT, 5034-MBSAXT			
5034-ENC	5034-MB, 5034-MBSA	5034-RTB18, 5034-RTB18S	5034-CM18-ENC-QTY5	-
5034-ENCXT	5034-MBXT, 5034-MBSAXT			
5034-MBPTM	-	5034-RTB18, 5034-RTB18S	5034-CM18-MBPTM-QTY5	-
5034-MBPTMXT				

PointMax I/O System Overview

Figure 1. PointMax I/O System



The PointMax™ I/O architecture provides a wide range of input and output modules to span many applications, such as machine, hybrid, and process control. The architecture uses Producer/Consumer technology that allows input information and output status to be shared among multiple Logix 5000 controllers. PointMax I/O systems are used as remote I/O modules with Logix 5000 controllers. You configure the modules with the Studio 5000 Logix Designer® application.

A PointMax I/O system consists of one EtherNet/IP adapter and supports up to 32 I/O modules. A 5034-EXP or 5034-EXPXT expansion power is required when using more than 16 I/O modules. The I/O modules are mounted on an MB and require an RTB to connect field-side wiring. You must purchase an MB and an RTB individually for each I/O module.

The PointMax I/O system is mounted onto a zinc-plated chromate-passivated steel DIN rail such as the Allen-Bradley® 199-DR1; 46277-4; EN 60715 - 35 x 7.5 mm (1.38 x 0.30 in.). You must also install DIN rail end anchors (Allen-Bradley 1492-EAJ35 or 1492-EAHJ35) at both ends of your system for vibration or shock environments. See PointMax I/O System Installation Instructions, publication [5034-IN001](#) for mounting guidelines.

The PointMax I/O system can be oriented in the following positions.

Figure 2. PointMax I/O System Mounting Orientations

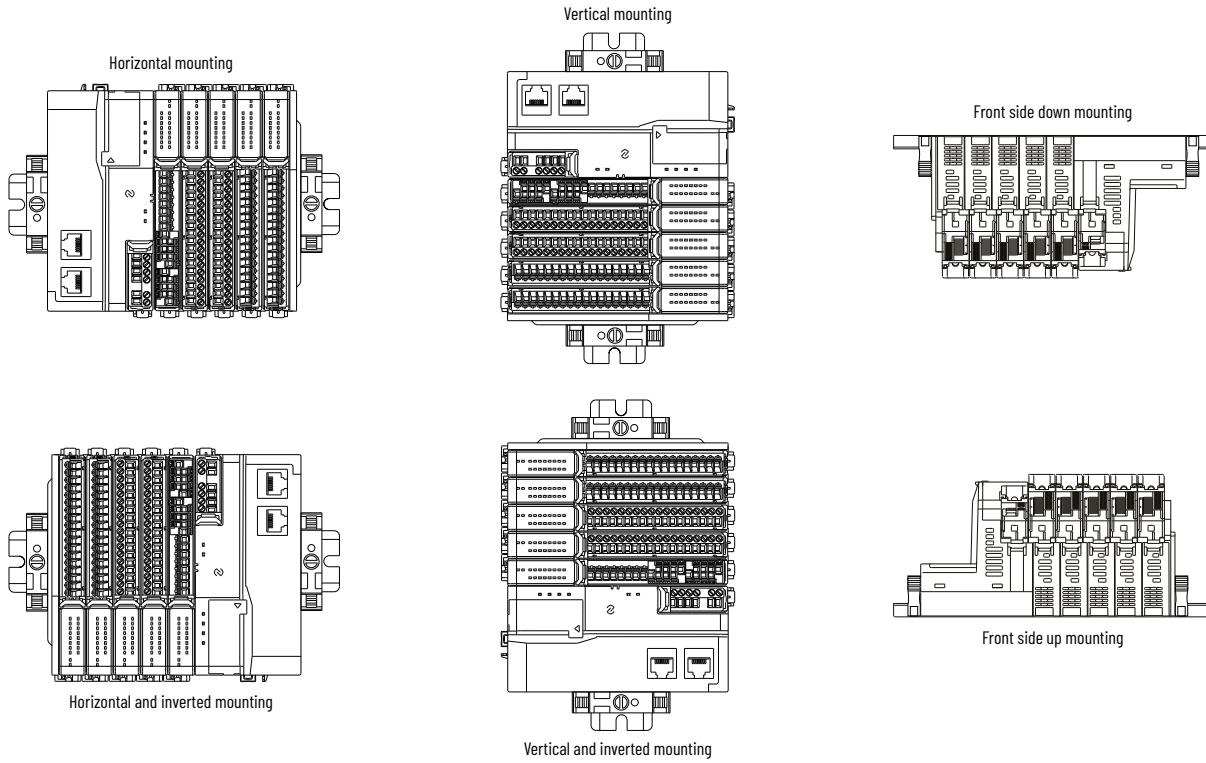

Spacing

Maintain spacing from enclosure walls, wireways, and adjacent equipment. Allow 25.4 mm (1 in.) of space on all sides for adequate ventilation.

Figure 3. Spacing Example

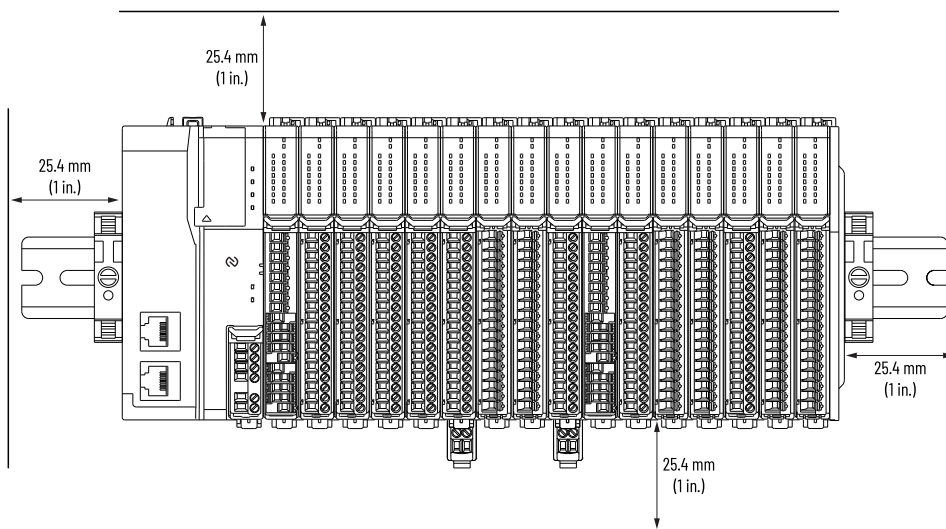

Dimensions

The dimension measurements that are provided in this publication are based on the horizontal mounting orientation.

Figure 4. Dimension Example

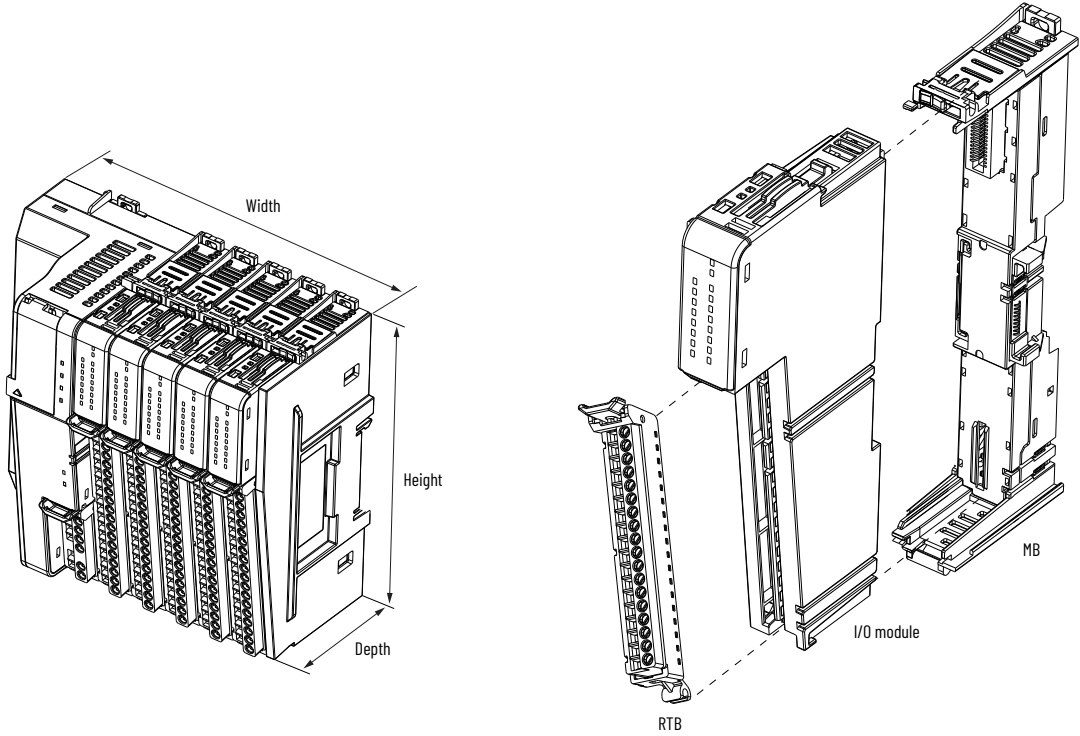

An I/O module, MB, and RTB are required to fill a slot in the chassis.

EtherNet/IP Adapter

Module Type	Catalog Number	Description
EtherNet/IP Adapter	5034-AENTR, 5034-AENTRXT	EtherNet/IP RJ45 adapter

Environmental specifications and certifications for PointMax EtherNet/IP adapter are provided in [Environmental Specifications and Certifications on page 13](#).

Specifications

Figure 5. 5034-AENTR and 5034-AENTRXT Wiring Diagram

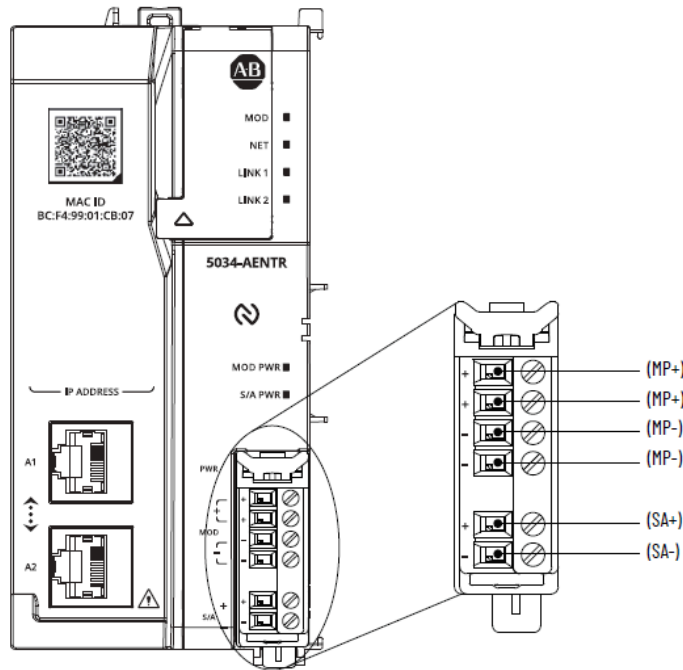

Table 3. Technical Specifications - 5034-AENTR, 5034-AENTRXT

Attribute	5034-AENTR, 5034-AENTRXT
Number of I/O modules supported	32 A 5034-EXP or 5034-EXPXT is required when using more than 16 I/O modules.
Number of MB supported	16 for 18...30V DC 8 for 10...18V DC
MP voltage, nom	24V DC SELV
MP voltage range	10...30V DC SELV
MP current, nom	0.6 A @ 24V DC
MP current, max	850 mA @ 10V DC (8 MB)

Table 3. Technical Specifications - 5034-AENTR, 5034-AENTRXT (continued)

Attribute	5034-AENTR, 5034-AENTRXT
	800 mA @ 18V DC (16 MB) 500 mA @ 30V DC (16 MB)
Voltage and current ratings, MP inrush, max	6 A for 10 ms @ 24V DC SELV
Voltage and current ratings, SA	10...30V DC SELV, 10 A Do not exceed 10 A current draw at the SA power RTB
Voltage and current ratings, backplane	16V DC, 300 mA max (8 MB) 16V DC, 600 mA max (16 MB)
SA power current at no load	2 mA
Power dissipation, max	3.6 W
Thermal dissipation, max	12.3 BTU/hr
Isolation voltage	250V (continuous), Basic Isolation, SA to backplane 250V (continuous), Basic Isolation, SA to MP 250V (continuous), Basic Isolation, Ethernet port to SA 60V (continuous), Basic Isolation, MP to backplane 60V (continuous), Basic Isolation, Ethernet port to MP 60V (continuous), Basic Isolation, Ethernet port to backplane No isolation between Ethernet ports
RTB supported	An RTB and end cap ships with the adapter. You can order additional screw-type (5034-AENRTB-QTY5) and push-in spring-type (5034-AENRTBS-QTY5) RTBs separately.
Wiring category ⁽¹⁾	2 - Power ports 2 - Ethernet ports
Wiring specification	See Wiring Specifications for Removable Terminal Blocks in the PointMax I/O System Specifications Technical Data, publication 5034-TD001
Indicators	1 green/red module status indicator 1 green/red network status indicator 2 green/red network connection status indicators 1 green module power status indicator 1 green SA power status indicator
Dimensions (HxWxD), approx	131.74 x 62.65 x 76 mm (5.18 x 2.46 x 2.99 in.)
Weight, approx	200 g (7.05 oz.) - 5034-AENTR

Table 3. Technical Specifications - 5034-AENTR, 5034-AENTRXT (continued)

Attribute	5034-AENTR, 5034-AENTRXT
	202 g (7.13 oz.) - 5034-AENTRXT
Enclosure type	None (Open-style)
North American temp code	T4
UKEX/ATEX temp code	T4
IECEx temp code	T4
NFC communication frequency	13.56 MHz passive type

(1) Use this Conductor Category information for planning conductor routing. See the Industrial Automation Wiring and Grounding Guidelines, publication [1770-4.1](#). Use this Conductor Category information for planning conductor routing as described in the appropriate System Level Installation Manual.

Environmental Specifications and Certifications

The following tables provide the environmental specifications and certifications for the PointMax EtherNet/IP adapter.

Table 4. Environmental Specifications - PointMax EtherNet/IP Adapter

Attribute	5034-AENTR	5034-AENTRXT
Temperature, operating	IEC 60068-2-1 (Test Ae, Operating Cold), IEC 60068-2-2 (Test Be, Operating Dry Heat), IEC 60068-2-14 (Test Nb, Operating Thermal Shock): -25 °C ≤ Ta ≤ +60 °C (-13 °F ≤ Ta ≤ +140 °F) for horizontal orientation -25 °C ≤ Ta ≤ +55 °C (-13 °F ≤ Ta ≤ +131 °F) for other orientations	
Temperature, surrounding air, max	60 °C (140 °F)	
Temperature, nonoperating	IEC 60068-2-1 (Test Ab, Unpackaged Nonoperating Cold), IEC 60068-2-2 (Test Bb, Unpackaged Nonoperating Dry Heat), IEC 60068-2-14 (Test Na, Unpackaged Nonoperating Thermal Shock): -40...+85 °C (-40...+185 °F)	
Relative humidity	IEC 60068-2-30 (Test Db, Unpackaged Damp Heat): 5...95% noncondensing	
Conformal coated	No	Yes
Corrosive Atmosphere ASTM B845-97 Method K Accelerated Test (20-Day Exposure)	Severity Level G3 ⁽¹⁾ (2) per ANSI/ISA 71.04-2013, Airborne Contaminants—Gases	—

Table 4. Environmental Specifications - PointMax EtherNet/IP Adapter (continued)

Attribute	5034-AENTR	5034-AENTRXT
Corrosive Atmosphere <ul style="list-style-type: none"> • ASTM B845-97 Method K Accelerated Test (30-Day Exposure) • Plus additional Rockwell Automation proprietary accelerated corrosive environment test protocol for specific industries with sources of gaseous sulfur compounds. 	–	Severity Level GX ⁽¹⁾⁽³⁾ per ANSI/ISA 71.04-2013, Airborne Contaminants—Gases Severity Level CX ⁽¹⁾ per IEC 60721-3-3:2019, Chemically Active Substances
Vibration	IEC 60068-2-6 (Test Fc, Operating): 5 g @ 10...500 Hz	
Shock, operating	IEC 60068-2-27 (Test Ea, Unpackaged Shock): 30 g	
Repetitive shock, operating	IEC 60068-2-27: 25 g, 6 ms duration, 1000 shocks in each ± direction in each 3 axis	
Shock, nonoperating	IEC 60068-2-27 (Test Ea, Unpackaged Shock): 50 g	
Emissions	IEC 61000-6-4: ETSI EN 300 330	
ESD immunity	IEC 61000-4-2: 6 kV contact discharges 8 kV air discharges ETSI EN 301 489-1: ETSI EN 301 489-3: 4 kV contact discharges 8 kV air discharges	
Radiated RF immunity	IEC 61000-4-3: 10V/m with 1 kHz sine wave 80% AM from 80...6000 MHz ETSI EN 301 489-1: ETSI EN 301 489-3: 3V/m with 1 kHz sine wave 80% AM from 80...6000 MHz	
EFT/B immunity	IEC 61000-4-4: ±3 kV @ 5 kHz on power ports ±3 kV @ 5 kHz on Ethernet ports	

Table 4. Environmental Specifications - PointMax EtherNet/IP Adapter (continued)

Attribute	5034-AENTR	5034-AENTRXT
	ETSI EN 301 489-1: ETSI EN 301 489-3: ±0.5 kV @ 5 kHz on power ports	
Surge transient immunity	IEC 61000-4-5: ETSI EN 301 489-1: ETSI EN 301 489-3: ±1 kV line-line (DM) and ±2 kV line-earth (CM) on power ports ±2 kV line-earth (CM) on Ethernet ports	
Conducted RF immunity	IEC 61000-4-6: 10V rms with 1 kHz sine wave 80% AM from 150 kHz...80 MHz ETSI EN 301 489-1: ETSI EN 301 489-3: 3V rms with 1 kHz sine wave 80% AM from 150 kHz...80 MHz	
Voltage dips and variations	IEC 61000-4-29: 10 ms interruption on MP ports	

(1) Dust caps must remain installed in unused ports at all times during storage and operation for the product to meet its corrosive atmosphere rating. The adapter and the corresponding RTB must remain installed at all times, once the factory packaging seal is broken, for the product to maintain its corrosive atmosphere rating.

(2) Up to 86.4 g/(m².yr), mass loss of copper due to corrosion.

(3) Up to 2100 angstroms of film growth per 30 days of copper and/or silver reactivity.

Table 5. Certifications - PointMax EtherNet/IP Adapter

Certification ⁽¹⁾	5034-AENTR, 5034-AENTRXT
c-UL-us	UL Listed Industrial Control Equipment, certified for US and Canada. See UL File E322657. UL Listed for Class I, Division 2 Group A,B,C,D Hazardous Locations, certified for U.S. and Canada. See UL File E334470.
UK and CE	UK Statutory Instrument 2016 No. 1091 and European Union 2014/30/EU EMC Directive, compliant with: EN 61326-1; Meas./Control/Lab., Industrial Requirements EN 61000-6-2; Industrial Immunity EN 61000-6-4; Industrial Emissions EN 61131-2; Programmable Controllers (Clause 8, Zone A & B) ETSI EN 301 489-1 V2.2.3; EMC requirements for radio equipment UK Statutory Instrument 2016 No. 1101 and European Union 2014/35/EU LVD, compliant with: EN 61010-2-201; Control Equipment Safety Requirements ETSI EN 301 489-3 V 2.3.2; EMC requirements for short range devices

Table 5. Certifications - PointMax EtherNet/IP Adapter (continued)

Certification ⁽¹⁾	5034-AENTR, 5034-AENTRXT
	UK Statutory Instrument 2012 No. 3032 and European Union 2011/65/EU RoHS, compliant with: EN IEC 63000; Technical documentation UK Statutory Instrument 2017 No. 1206 and European Union 2014/53/EU Radio Equipment Directive, compliant with: ETSI EN 300 330 V2.1.1; Radio requirements for short range devices
RCM	Australian Radiocommunications Act, compliant with: EN 61000-6-4; Industrial Emissions ETSI EN 301 489-1 V2.2.3; EMC requirements for radio equipment ETSI EN 301 489-3 V2.3.2; EMC requirements for short range devices ETSI EN 300 330 V2.1.1; Radio requirements for short range devices
Ex	UK Statutory Instrument 2016 No. 1107 and European Union 2014/34/EU ATEX Directive, compliant with: EN IEC 60079-0; General Requirements EN IEC 60079-7; Explosive Atmospheres, Protection "e" II 3 G Ex ec IIC T4 Gc UL 24 ATEX 3272X and UL24UKEX2997X
IECEx	IECEx System, compliant with: IEC 60079-0; General Requirements IEC 60079-7; Explosive Atmospheres, Protection "e" II 3 G Ex ec IIC T4 Gc IECEx UL 24.0066X
FCC	FCC Part 15B Class A
KC	Korean Registration of Broadcasting and Communications Equipment, compliant with: Article 58-2 of Radio Waves Act, Clause 4
Morocco	Arrêté ministériel n° 6404-15 du 1 er muharram 1437 Arrêté ministériel n° 6404-15 du 29 ramadan 1436
CCC	CNCA-C23-01 强制性产品认证实施规则 防爆电气 CNCA-C23-01 CCC Implementation Rule Explosion-Proof Electrical Products 2025122309123247
ISED	ICES-001
EtherNet/IP	ODVA conformance tested to EtherNet/IP specifications
NFC	Country-specific

Table 5. Certifications - PointMax EtherNet/IP Adapter (continued)

Certification ⁽¹⁾	5034-AENTR, 5034-AENTRXT
	For a list of countries in which the product is certified for NFC, see 5034-CT100 .

(1) When marked. See the Product Certifications website at rok.auto/certifications for declarations of conformity, certificates, and other certification details.

Mounting Bases

Module Type	Catalog Number	Description
Mounting Base	5034-MB, 5034-MBXT	Mounting base - 15 mm (0.59 in.)
	5034-MBSA, 5034-MBSAXT	Mounting base - 15 mm (0.59 in.) with SA power

Environmental specifications and certifications for PointMax mounting bases are provided in [Environmental Specifications and Certifications on page 20](#).

5034-MB and 5034-MBXT Mounting Bases

Figure 6. 5034-MB Diagram

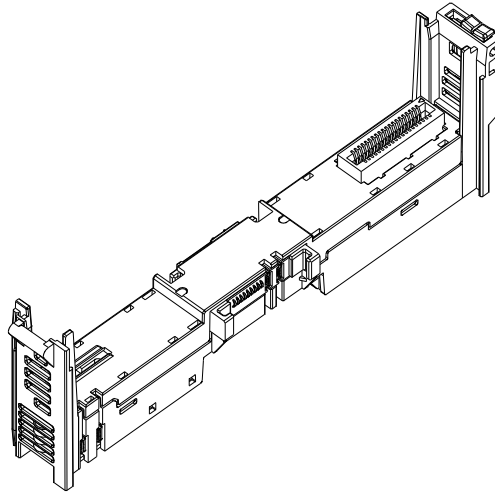

Table 6. General Specifications - 5034-MB, 5034-MBXT

Attribute	5034-MB, 5034-MBXT
SA power, operating voltage, nom	Passthrough
SA power, operating voltage range	Passthrough
SA power, current, max	Passthrough
Power dissipation, max	0.5 W
Isolation voltage	250V (continuous), Basic Insulation Type, SA to backplane
Dimensions (HxWxD), approx Without I/O module	132 x 15 x 4.3 mm (5.2 x 0.59 x 1.69 in.)
Weight, approx	34 g (1.20 oz.) - 5034-MB 35 g (1.23 oz.) - 5034-MBXT

Table 6. General Specifications - 5034-MB, 5034-MBXT (continued)

Attribute	5034-MB, 5034-MBXT
Enclosure type	None (Open-style)
North American temp code	T4
UKEX/ATEX temp code	T4
IECEx temp code	T4

5034-MBSA and 5034-MBSAXT Mounting Bases with SA Power

Figure 7. 5034-MBSA Wiring Diagram

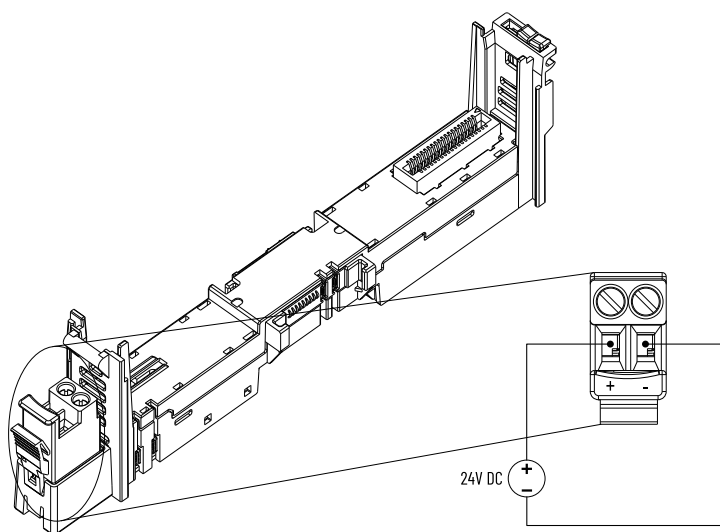

Table 7. General Specifications - 5034-MBSA, 5034-MBSAXT

Attribute	5034-MBSA, 5034-MBSAXT
SA power, operating voltage, nom	24V DC, SELV
SA power, operating voltage range	10...30V DC, SELV
SA power, current, max	10 A
Power dissipation, max	0.5 W
Isolation voltage	250V (continuous), Basic Insulation Type, SA to backplane
RTB supported	An RTB ships with the product. You can order additional screw-type (5034-RTB2-QTY5) and push-in spring-type (5034-RTB2S-QTY5) separately.
Wiring category ⁽¹⁾	2 - Power ports

Table 7. General Specifications - 5034-MBSA, 5034-MBSAXT (continued)

Attribute	5034-MBSA, 5034-MBSAXT
Wiring specification	See Wiring Specifications for Removable Terminal Blocks in the PointMax I/O System Specifications Technical Data, publication 5034-TD001
Dimensions (HxWxD), approx Without I/O module	149 x 15 x 43 mm (5.87 x 0.59 x 1.69 in.)
Weight, approx	37 g (1.30 oz.) - 5034-MBSA 38 g (1.34 oz.) - 5034-MBSAXT
Enclosure type	None (Open-style)
North American temp code	T4
UKEX/ATEX temp code	T4
IECEx temp code	T4

(1) Use this Conductor Category information for planning conductor routing. See the Industrial Automation Wiring and Grounding Guidelines, publication [1770-4.1](#). Use this Conductor Category information for planning conductor routing as described in the appropriate System Level Installation Manual.

Environmental Specifications and Certifications

The following tables provide the environmental specifications and certifications for the PointMax mounting bases.

Table 8. Environmental Specifications - PointMax Mounting Bases

Attribute	5034-MB, 5034-MBSA	5034-MBXT, 5034-MBSAXT
Temperature, operating	IEC 60068-2-1 (Test Ae, Operating Cold), IEC 60068-2-2 (Test Be, Operating Dry Heat), IEC 60068-2-14 (Test Nb, Operating Thermal Shock): -25 °C ≤ Ta ≤ +60 °C (-13 °F ≤ Ta ≤ +140 °F) for horizontal orientation -25 °C ≤ Ta ≤ +55 °C (-13 °F ≤ Ta ≤ +131 °F) for other orientations	
Temperature, surrounding air, max	60 °C (140 °F)	
Temperature, nonoperating	IEC 60068-2-1 (Test Ab, Unpackaged Nonoperating Cold), IEC 60068-2-2 (Test Bb, Unpackaged Nonoperating Dry Heat), IEC 60068-2-14 (Test Na, Unpackaged Nonoperating Thermal Shock): -40...+85 °C (-40...+185 °F)	
Relative humidity	IEC 60068-2-30 (Test Db, Unpackaged Damp Heat): 5...95% noncondensing	

Table 8. Environmental Specifications - PointMax Mounting Bases (continued)

Attribute	5034-MB, 5034-MBSA	5034-MBXT, 5034-MBSAXT
Conformal coated	No	Yes
Corrosive Atmosphere ASTM B845-97 Method K Accelerated Test (20-Day Exposure)	Severity Level G3 ⁽¹⁾ per ANSI/ISA 71.04-2013, Airborne Contaminants—Gases	—
Corrosive Atmosphere • ASTM B845-97 Method K Accelerated Test (30-Day Exposure) • Plus additional Rockwell Automation proprietary accelerated corrosive environment test protocol for specific industries with sources of gaseous sulfur compounds.	—	Severity Level GX ⁽²⁾ per ANSI/ISA 71.04-2013, Airborne Contaminants—Gases Severity Level CX per IEC 60721-3-3:2019, Chemically Active Substances
Vibration	IEC 60068-2-6 (Test Fc, Operating): 5 g @ 10...500 Hz	
Shock, operating	IEC 60068-2-27 (Test Ea, Unpackaged Shock): 30 g	
Repetitive shock, operating	IEC 60068-2-27: 25 g, 6 ms duration, 1000 shocks in each ± direction in each 3 axis	
Shock, nonoperating	IEC 60068-2-27 (Test Ea, Unpackaged Shock): 50 g	

(1) Up to 86.4 g/(m².yr), mass loss of copper due to corrosion.

(2) Up to 2100 angstroms of film growth per 30 days of copper and/or silver reactivity.

Table 9. Certifications - PointMax Mounting Bases

Certification ⁽¹⁾	5034-MB, 5034-MBXT, 5034-MBSA, 5034-MBSAXT
c-UL-us	UL Listed Industrial Control Equipment, certified for US and Canada. See UL File E322657. UL Listed for Class I, Division 2 Group A,B,C,D Hazardous Locations, certified for U.S. and Canada. See UL File E334470.
UK and CE	UK Statutory Instrument 2016 No. 1091 and European Union 2014/30/EU EMC Directive, compliant with: EN 61326-1; Meas./Control/Lab., Industrial Requirements EN 61000-6-2; Industrial Immunity EN 61000-6-4; Industrial Emissions

Table 9. Certifications - PointMax Mounting Bases (continued)

Certification ⁽¹⁾	5034-MB, 5034-MBXT, 5034-MBSA, 5034-MBSAXT
	EN 61131-2; Programmable Controllers (Clause 8, Zone A & B) UK Statutory Instrument 2016 No. 1101 and European Union 2014/35/EU LVD, compliant with: EN 61010-2-201; Control Equipment Safety Requirements UK Statutory Instrument 2012 No. 3032 and European Union 2011/65/EU RoHS, compliant with: EN IEC 63000; Technical documentation
RCM	Australian Radiocommunications Act, compliant with: EN 61000-6-4; Industrial Emissions
Ex	UK Statutory Instrument 2016 No. 1107 and European Union 2014/34/EU ATEX Directive, compliant with: EN IEC 60079-0; General Requirements EN IEC 60079-7; Explosive Atmospheres, Protection "e" II 3 G Ex ec IIC T4 Gc UL 24 ATEX 3272X and UL24UKEX2997X
IECEX	IECEX System, compliant with: IEC 60079-0; General Requirements IEC 60079-7; Explosive Atmospheres, Protection "e" II 3 G Ex ec IIC T4 Gc IECEX UL 24.0066X
KC	Korean Registration of Broadcasting and Communications Equipment, compliant with: Article 58-2 of Radio Waves Act, Clause 4
Morocco	Arrêté ministériel n° 6404-15 du 1 er muharram 1437 Arrêté ministériel n° 6404-15 du 29 ramadan 1436

(1) When marked. See the Product Certifications website at rok.auto/certifications for declarations of conformity, certificates, and other certification details.

Digital I/O Modules

I/O Type	Catalog Number	Description
Digital Input	5034-IB16, 5034-IB16XT	Digital 16 input
	5034-IB8, 5034-IB8XT	Digital 8 input
Digital Output	5034-OB16, 5034-OB16XT	Digital 16 output
	5034-OB8, 5034-OB8XT	Digital 8 output
	5034-OB4, 5034-OB4XT	Digital 4 output 2 A
Relay Output	5034-OW4I, 5034-OW4IXT	Relay 4 output isolated 2 A
Configurable Input/Output	5034-UB8, 5034-UB8XT	Digital 8 input/output
	5034-UB8F, 5034-UB8FXT	Fast digital 8 input/output

Environmental specifications and certifications for PointMax digital I/O modules are provided in [Environmental Specifications and Certifications on page 58](#).

5034-IB16 and 5034-IB16XT Digital 16 Input Modules

Figure 8. 5034-IB16 and 5034-IB16XT Wiring Diagram

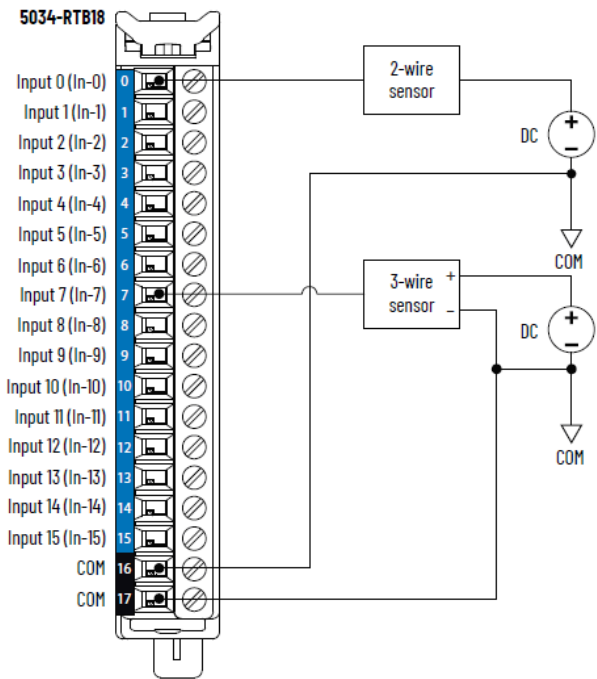

To establish more COM connections, install a 5034-MBPTM or 5034-MBPTMXT next to the module.

Figure 9. 5034-IB16 and 5034-IB16XT Functional Block Diagram

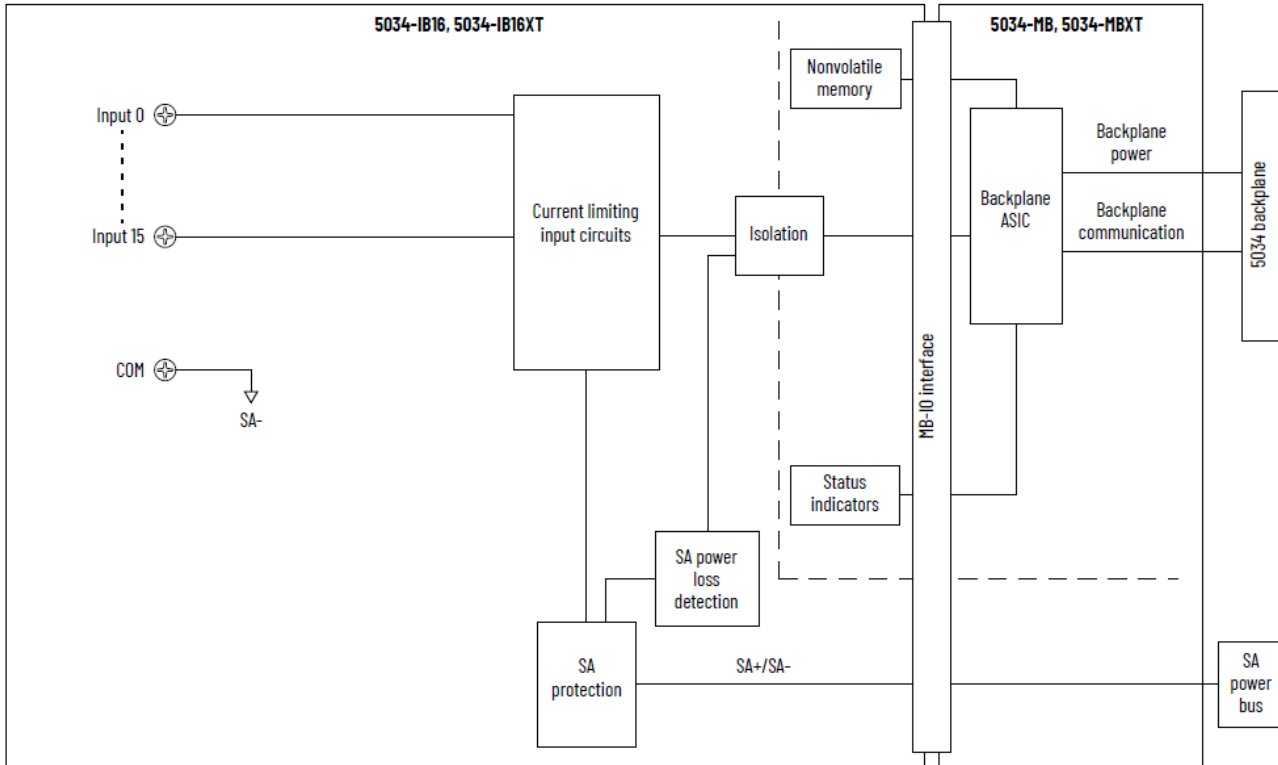

Table 10. Technical Specifications - 5034-IB16, 5034-IB16XT

Attribute	5034-IB16, 5034-IB16XT
On-state voltage range	10...30V DC
On-state current, min	2 mA
On-state current, nom	2.4 mA
On-state current, max	2.8 mA
Off-state voltage, max	5V DC
Off-state current, max	1.5 mA
Input impedance, min	3.57 kΩ @ 10V DC
Input impedance, nom	10 kΩ @ 24V DC
Input impedance, max	15 kΩ @ 30V DC
Input delay time (screw to backplane), max	150 μs
Off-to-On	
On-to-Off	
Input pulse width, min	125 μs
Off-to-On	

Table 10. Technical Specifications - 5034-IB16, 5034-IB16XT (continued)

Attribute	5034-IB16, 5034-IB16XT
On-to-Off	
Input filter time	0 μs, 100 μs, 200 μs, 500 μs, 1 ms (Default), 2 ms, 5 ms, 10 ms, 20 ms, 50 ms
Off-to-On	
On-to-Off	
Simple counters, counter frequency	0...f _{max} = 4000 Hz 4 (with 12 points as standard inputs) or 8 (with 8 points as standard inputs) Point 0...7 only
Timestamp of inputs (sequence of events)	Yes, ±100 μs accuracy
Events	Not supported

Table 11. General Specifications - 5034-IB16, 5034-IB16XT

Attribute	5034-IB16, 5034-IB16XT
Number of inputs	16 channels (1 group of 16), sinking
Voltage category	12/24V DC sink
Input voltage, nom	24V DC
Input voltage range	10...30V DC
SA power voltage, nom	24V DC
SA power voltage range	10...30V DC
SA power current, nom	20 mA
SA power current, max	0.1 A
SA power current at no load	10 mA
SA reverse polarity protection	Yes
Power dissipation, max ⁽¹⁾	1.45 W
Thermal dissipation, max ⁽¹⁾	4.95 BTU/hr
Isolation voltage	250V (continuous), Basic Insulation Type, System to Field No isolation between SA power and inputs No isolation between individual inputs
RIUP support	Yes

Table 11. General Specifications - 5034-IB16, 5034-IB16XT (continued)

Attribute	5034-IB16, 5034-IB16XT
CIP Sync	Yes, slave only ordinary clock
Electronic keying	Electronic keying via programming software
RTB key positions (slot)	1, 4, 11
RTB supported	5034-RTB18, 5034-RTB18S
Wiring category ⁽²⁾	2 - Signal ports 2 - Power ports
Wiring specification	See Wiring Specifications for Removable Terminal Blocks in the PointMax I/O System Specifications Technical Data, publication 5034-TD001
Indicators	1 green/red module status indicator 1 green/red SA power status indicator 16 yellow I/O status indicators
Dimensions (HxWxD), approx	123.6 x 15.0 x 66.4 mm (4.87 x 0.59 x 2.61 in.)
Weight, approx	43.0 g (1.52 oz.) - 5034-IB16 45.0 g (1.59 oz.) - 5034-IB16XT
Enclosure type	None (Open-style)
North American temp code	T4
UKEX/ATEX temp code	T4
IECEx temp code	T4

(1) Value is measured at 60 °C (140 °F). Power dissipation varies with temperature.

(2) Use this Conductor Category information for planning conductor routing. See the Industrial Automation Wiring and Grounding Guidelines, publication [1770-4.1](#). Use this Conductor Category information for planning conductor routing as described in the appropriate System Level Installation Manual.

5034-IB8 and 5034-IB8XT Digital 8 Input Modules

Figure 10. 5034-IB8 and 5034-IB8XT Wiring Diagram

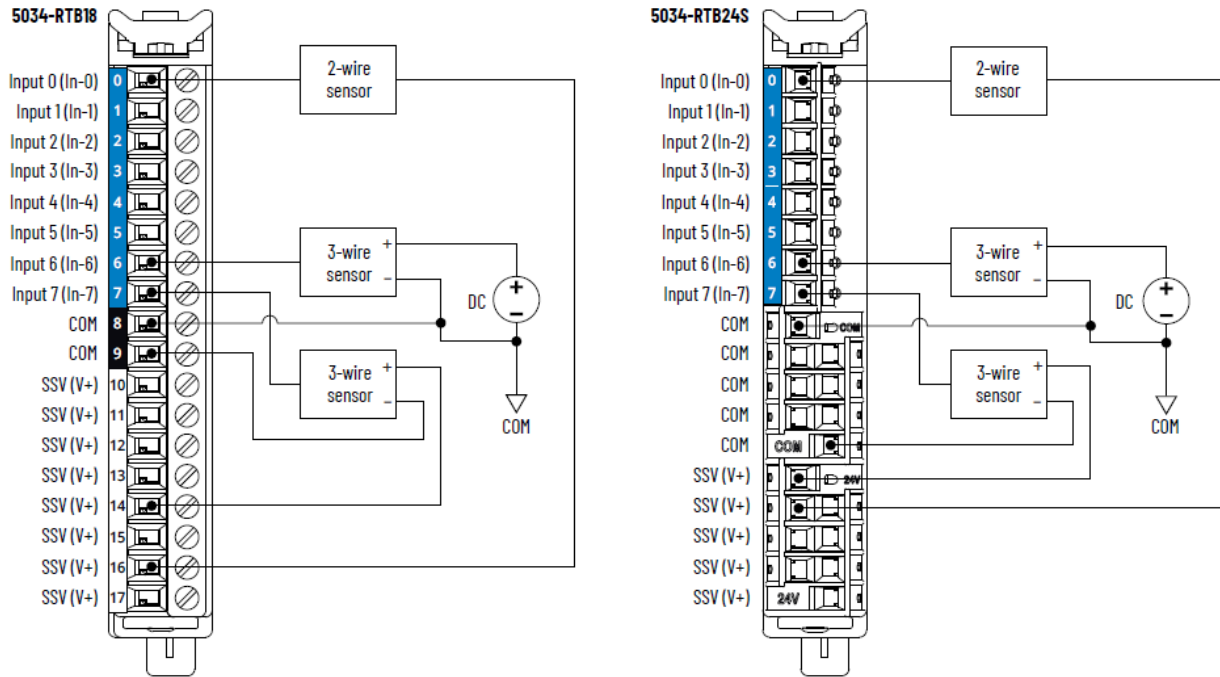

To establish more COM/V+ connections, use a 5034-RTB24S, or install a 5034-MBPTM or 5034-MBPTMXT next to the module.

Figure 11. 5034-IB8 and 5034-IB8XT Functional Block Diagram

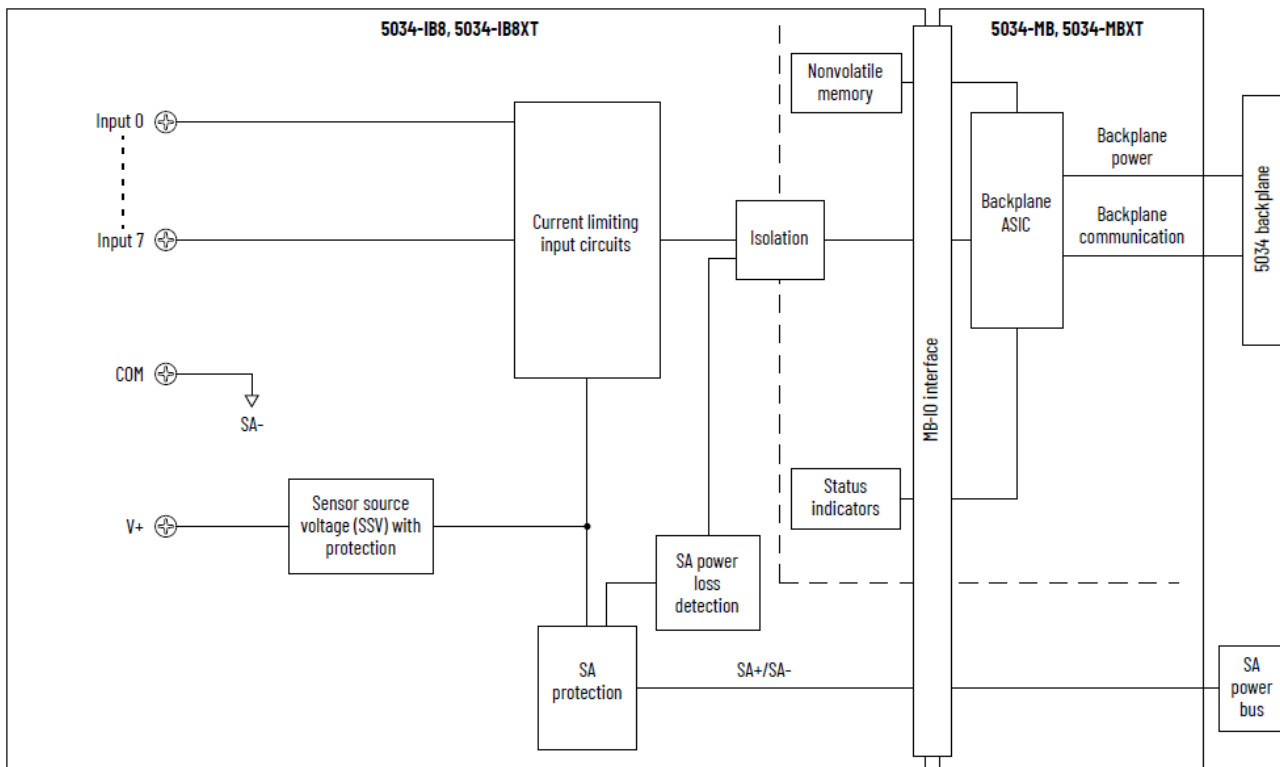

Table 12. Technical Specifications - 5034-IB8, 5034-IB8XT

Attribute	5034-IB8, 5034-IB8XT
On-state voltage range	10...30V DC
On-state current, min	2 mA
On-state current, nom	2.4 mA
On-state current, max	2.8 mA
Off-state voltage, max	5V DC
Off-state current, max	1.5 mA
Input impedance, min	3.57 kΩ @ 10V DC
Input impedance, nom	10 kΩ @ 24V DC
Input impedance, max	15 kΩ @ 30V DC
Input delay time (screw to backplane), max Off-to-On On-to-Off	150 μs
Input pulse width, min Off-to-On On-to-Off	125 μs
Input filter time Off-to-On On-to-Off	0 μs, 100 μs, 200 μs, 500 μs, 1 ms (Default), 2 ms, 5 ms, 10 ms, 20 ms, 50 ms
Simple counters, counter frequency	0...f _{max} = 4000 Hz 4 (with 4 points as standard inputs) Point 0...3 only
Timestamp of inputs (sequence of events)	Yes, ±100 μs accuracy
Events	Not supported

Table 13. General Specifications - 5034-IB8, 5034-IB8XT

Attribute	5034-IB8, 5034-IB8XT
Number of inputs	8 channels (1 group of 8), sinking
Voltage category	12/24V DC sink
Input voltage, nom	24V DC

Table 13. General Specifications - 5034-IB8, 5034-IB8XT (continued)

Attribute	5034-IB8, 5034-IB8XT
Input voltage range	10...30V DC
SA power voltage, nom	24V DC
SA power voltage range	10...30V DC
SA power current, nom	250 mA
SA power current, max	0.3 A
SA power current at no load	10 mA
SA reverse polarity protection	Yes
SSV voltage range	Follow SA supply
SSV current, max	0.2 A
SSV short-circuit protection	Yes
Power dissipation, max ⁽¹⁾	1.15 W
Thermal dissipation, max ⁽¹⁾	3.92 BTU/hr
Isolation voltage	250V (continuous), Basic Insulation Type, System to Field No isolation between SA power and inputs No isolation between individual inputs
RIUP support	Yes
CIP Sync	Yes, slave only ordinary clock
Electronic keying	Electronic keying via programming software
RTB key positions (slot)	1, 4, 8
RTB supported	5034-RTB18, 5034-RTB18S, 5034-RTB24S
Wiring category ⁽²⁾	2 - Signal ports 2 - Power ports
Wiring specification	See Wiring Specifications for Removable Terminal Blocks in the PointMax I/O System Specifications Technical Data, publication 5034-TD001
Indicators	1 green/red module status indicator 1 green/red SA power status indicator 8 yellow I/O status indicators
Dimensions (HxWxD), approx	123.6 x 15.0 x 66.4 mm (4.87 x 0.59 x 2.61 in.)

Table 13. General Specifications - 5034-IB8, 5034-IB8XT (continued)

Attribute	5034-IB8, 5034-IB8XT
Weight, approx	43.0 g (1.52 oz.) - 5034-IB8 46.0 g (1.62 oz.) - 5034-IB8XT
Enclosure type	None (Open-style)
North American temp code	T4
UKEX/ATEX temp code	T4
IECEx temp code	T4

(1) Value is measured at 60 °C (140 °F). Power dissipation varies with temperature.

(2) Use this Conductor Category information for planning conductor routing. See the Industrial Automation Wiring and Grounding Guidelines, publication [1770-4.1](#). Use this Conductor Category information for planning conductor routing as described in the appropriate System Level Installation Manual.

5034-OB16 and 5034-OB16XT Digital 16 Output Modules

Figure 12. 5034-OB16 and 5034-OB16XT Wiring Diagram

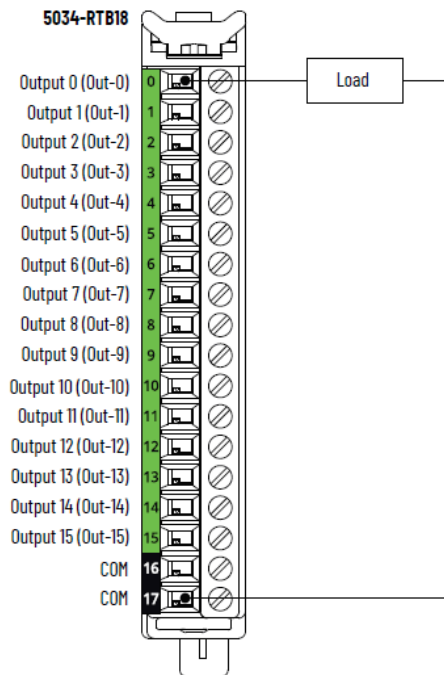

Figure 13. 5034-OB16 and 5034-OB16XT Functional Block Diagram

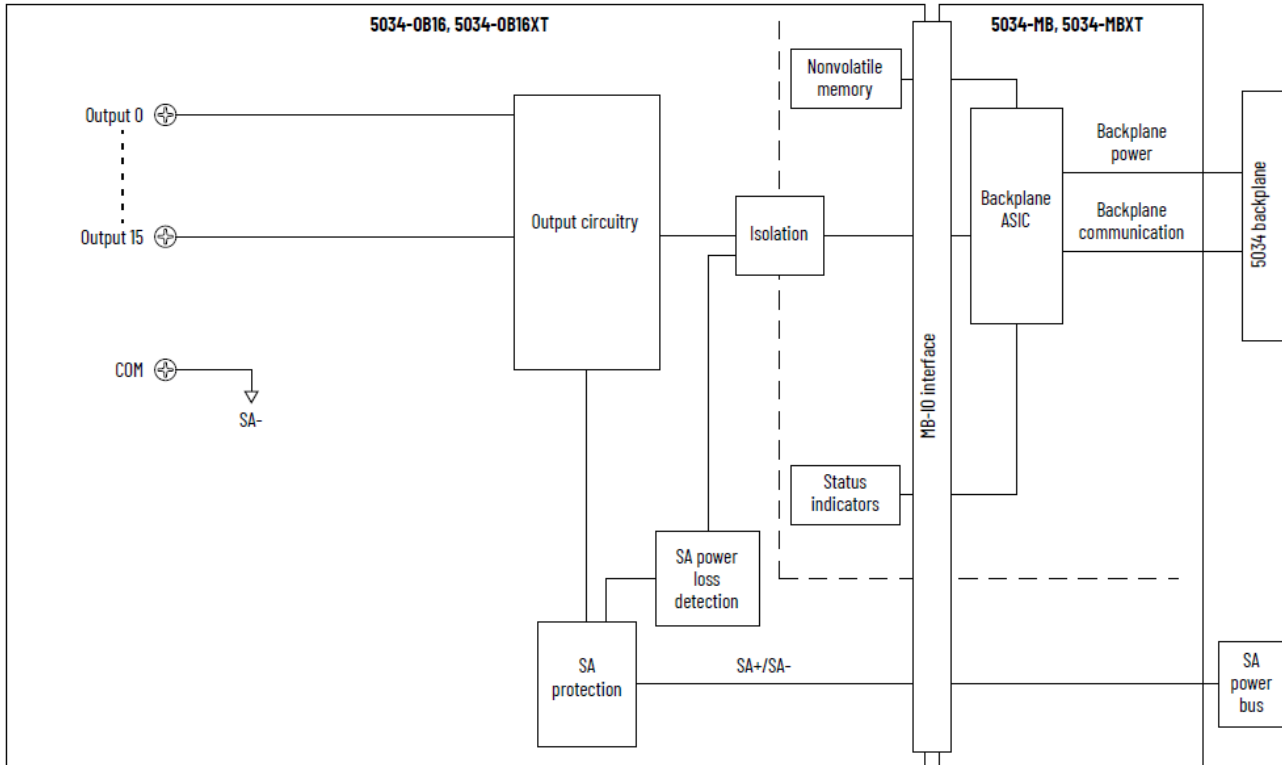

Table 14. Technical Specifications - 5034-OB16, 5034-OB16XT

Attribute	5034-OB16, 5034-OB16XT
On-state voltage range	10...30V DC
On-state voltage drop, max	0.25V DC
On-state current per point, min	1 mA
Off-state voltage, max Off-state open wire detection disabled	5V DC with 1 mA min load
Off-state voltage, max Off-state open wire detection enabled	5V DC with 5 mA min load
Off-state leakage current per point, max Off-state open wire detection disabled	0.05 mA
Off-state leakage current per point, max ⁽¹⁾ Off-state open wire detection enabled	0.5 mA
Output current rating per point, max	0.5 A
Output current rating per module, max	5 A
Surge current per point, max	1.5 A for 10 ms, repeatable every 3 s

Table 14. Technical Specifications - 5034-0B16, 5034-0B16XT (continued)

Attribute	5034-0B16, 5034-0B16XT
Fast inductive load turn-off	Yes
Inductive load allowed, max	1.2 H
Output clamping voltage for inductive load when turn off	SA voltage - 44V Typical is -20V when SA voltage is 24V
Output delay time (backplane to screw), max Off-to-On On-to-Off	120 μ s @ 0.5 A
Pulse width, min	200 μ s
Open load detection diagnostics	Yes, configurable (Default is off)
Output short circuit/overload detection	Yes
Output short circuit/overload protection	Yes
Pilot duty rating	1.5 A inrush current, 0.5 A rated current, DC-14
Output states in program mode per point	Hold Last State On Off (Default)
Output states in fault mode per point	Hold Last State On Off (Default)
Duration of fault mode per point	1 s 2 s 5 s 10 s Forever (Default)
Output final state after fault mode per point	On Off (Default)
Scheduled outputs	Supported, accuracy \pm 100 μ s

(1) Recommended Loading Resistor - To limit the effects of leakage current through solid-state outputs, you can connect a loading resistor in parallel with your load. For 24V DC operation, use a 5.6 k Ω , 0.5 W resistor for transistor operation.

Table 15. General Specifications - 5034-OB16, 5034-OB16XT

Attribute	5034-OB16, 5034-OB16XT
Number of outputs	16 channels (1 group of 16), sourcing
Voltage category	24V DC source
Output voltage, nom	24V DC
Output voltage range	10...30V DC
SA power voltage, nom	24V DC
SA power voltage range	10...30V DC
SA power current, nom	5.1 A
SA power current, max	5.2 A
SA power current at no load	13 mA
SA reverse polarity protection	Yes
Power dissipation, max ⁽¹⁾	1.02 W
Thermal dissipation, max ⁽¹⁾	3.48 BTU/hr
Isolation voltage	250V (continuous), Basic Insulation Type, System to Field No isolation between SA power and outputs No isolation between individual outputs
RIUP support	Yes
CIP Sync	Yes, slave only ordinary clock
Electronic keying	Electronic keying via programming software
RTB key positions (slot)	1, 5, 11
RTB supported	5034-RTB18, 5034-RTB18S
Wiring category ⁽²⁾	2 - Signal ports 2 - Power ports
Wiring specification	See Wiring Specifications for Removable Terminal Blocks in the PointMax I/O System Specifications Technical Data, publication 5034-TD001
Indicators	1 green/red module status indicator 1 green/red SA power status indicator 16 yellow/red I/O status indicators
Dimensions (HxWxD), approx	123.6 x 15.0 x 66.4 mm (4.87 x 0.59 x 2.61 in.)

Table 15. General Specifications - 5034-OB16, 5034-OB16XT (continued)

Attribute	5034-OB16, 5034-OB16XT
Weight, approx	43.0 g (1.52 oz.) - 5034-OB16 45.0 g (1.59 oz.) - 5034-OB16XT
Enclosure type	None (Open-style)
North American temp code	T4
UKEX/ATEX temp code	T4
IECEx temp code	T4

(1) Value is measured at 60 °C (140 °F). Power dissipation varies with temperature.

(2) Use this Conductor Category information for planning conductor routing. See the Industrial Automation Wiring and Grounding Guidelines, publication [1770-4.1](#). Use this Conductor Category information for planning conductor routing as described in the appropriate System Level Installation Manual.

5034-OB8 and 5034-OB8XT Digital 8 Output Modules

Figure 14. 5034-OB8 and 5034-OB8XT Wiring Diagram

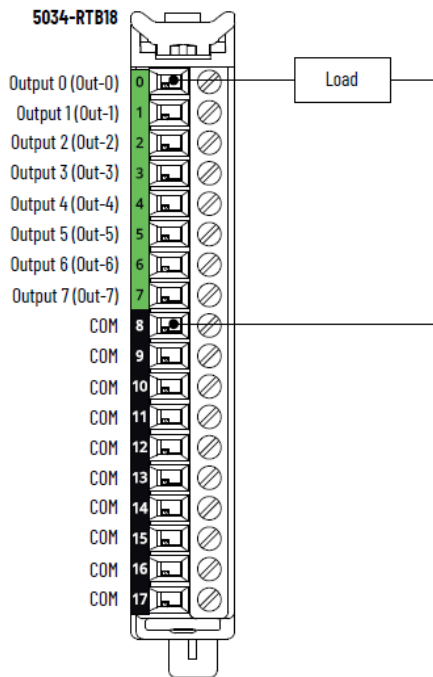

Figure 15. 5034-OB8 and 5034-OB8XT Wiring Diagram – Individual Load Return Wiring on COM Pins

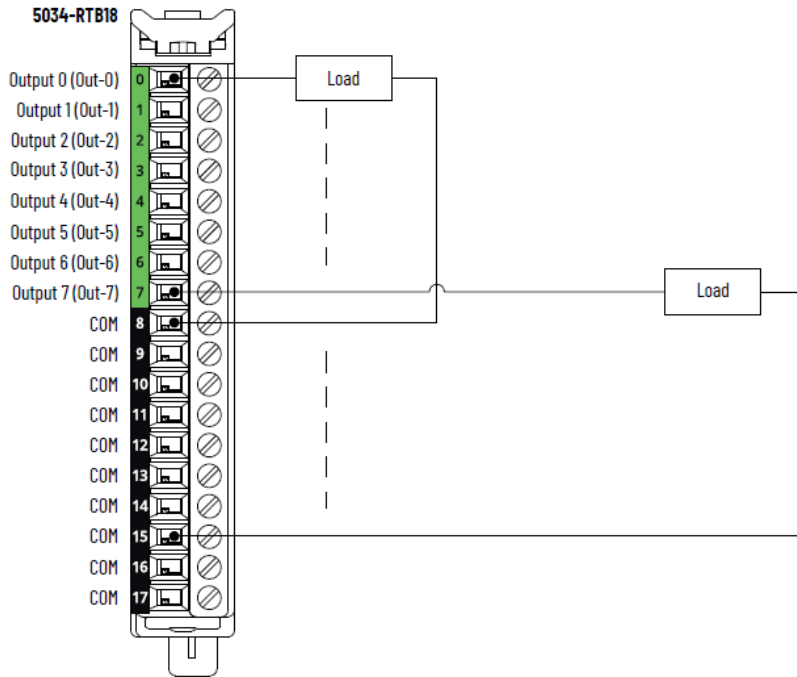
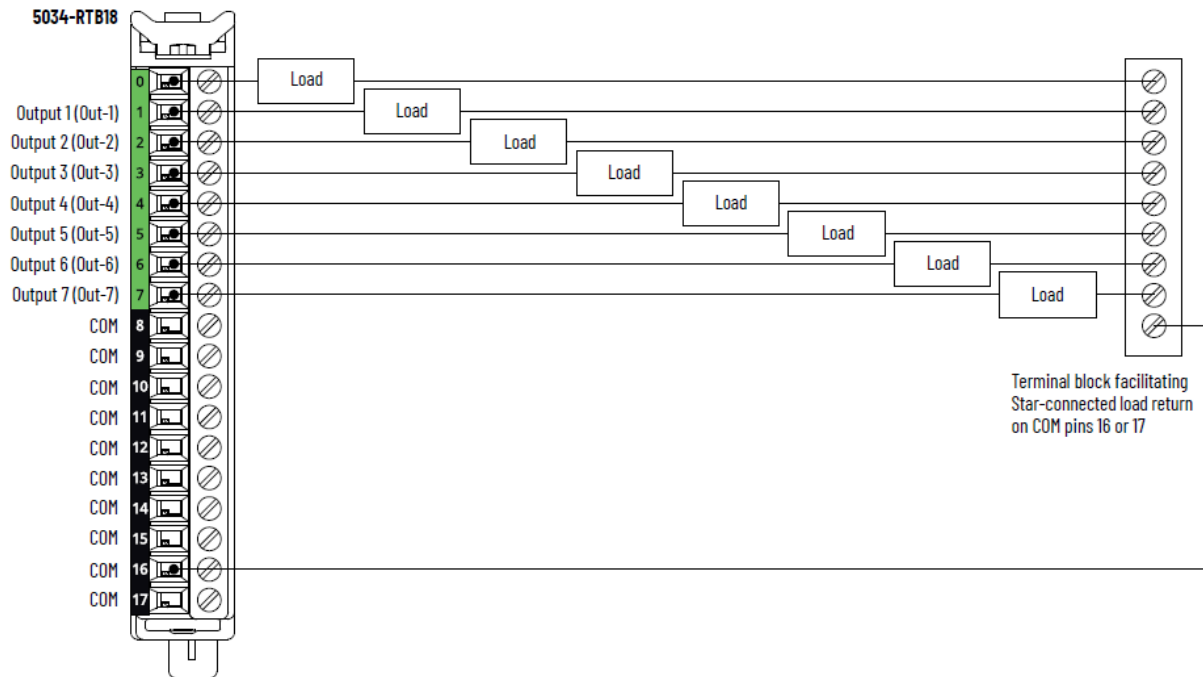

Figure 16. 5034-OB8 and 5034-OB8XT Wiring Diagram – Star-connected Load Return Wiring on COM Pins



IMPORTANT: Use only COM pins 16 and 17 for the star-connected load return wiring.

Figure 17. 5034-OB8 and 5034-OB8XT Functional Block Diagram

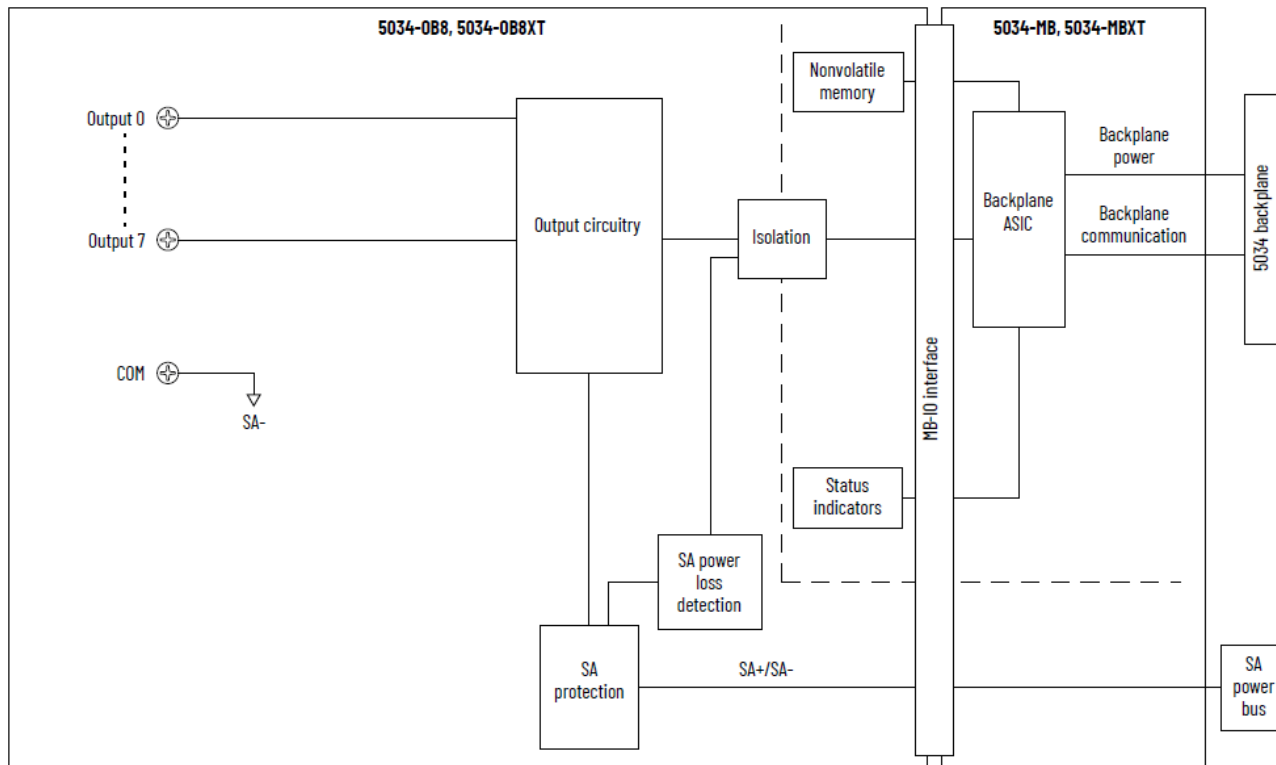

Table 16. Technical Specifications - 5034-OB8, 5034-OB8XT

Attribute	5034-OB8, 5034-OB8XT
On-state voltage range	10...30V DC
On-state voltage drop, max	0.25V DC
On-state current per point, min	1 mA
Off-state voltage, max	5V DC with 1 mA min load
Off-state open wire detection disabled	
Off-state voltage, max	5V DC with 5 mA min load
Off-state open wire detection enabled	
Off-state leakage current per point, max	0.05 mA
Off-state open wire detection disabled	
Off-state leakage current per point, max ⁽¹⁾	0.5 mA
Off-state open wire detection enabled	
Output current rating per point, max	0.5 A
Output current rating per module, max	4 A
Surge current per point, max	1.5 A for 10 ms, repeatable every 3 s

Table 16. Technical Specifications - 5034-0B8, 5034-0B8XT (continued)

Attribute	5034-0B8, 5034-0B8XT
Fast inductive load turn-off	Yes
Inductive load allowed, max	1.2 H
Output clamping voltage for inductive load when turn off	SA voltage - 44V Typical is -20V when SA voltage is 24V
Output delay time (backplane to screw), max Off-to-On On-to-Off	120 μ s @ 0.5 A
Pulse width, min	200 μ s
Open load detection diagnostics	Yes, configurable (Default is off)
Output short circuit/overload detection	Yes
Output short circuit/overload protection	Yes
Pilot duty rating	1.5 A inrush current, 0.5 A rated current, DC-14
Output states in program mode per point	Hold Last State On Off (Default)
Output states in fault mode per point	Hold Last State On Off (Default)
Duration of fault mode per point	1 s 2 s 5 s 10 s Forever (Default)
Output final state after fault mode per point	On Off (Default)
Scheduled outputs	Supported, accuracy \pm 100 μ s

(1) Recommended Loading Resistor - To limit the effects of leakage current through solid-state outputs, you can connect a loading resistor in parallel with your load. For 24V DC operation, use a 5.6 k Ω , 0.5 W resistor for transistor operation.

Table 17. General Specifications - 5034-0B8, 5034-0B8XT

Attribute	5034-0B8, 5034-0B8XT
Number of outputs	8 channels (1 group of 8), sourcing
Voltage category	24V DC source
Output voltage, nom	24V DC
Output voltage range	10...30V DC
SA power voltage, nom	24V DC
SA power voltage range	10...30V DC
SA power current, nom	4.1 A
SA power current, max	4.2 A
SA power current at no load	12 mA
SA reverse polarity protection	Yes
Power dissipation, max ⁽¹⁾	0.91 W
Thermal dissipation, max ⁽¹⁾	3.11 BTU/hr
Isolation voltage	250V (continuous), Basic Insulation Type, System to Field No isolation between SA power and outputs No isolation between individual outputs
RIUP support	Yes
CIP Sync	Yes, slave only ordinary clock
Electronic keying	Electronic keying via programming software
RTB key positions (slot)	1, 5, 11
RTB supported	5034-RTB18, 5034-RTB18S
Wiring category ⁽²⁾	2 - Signal ports 2 - Power ports
Wiring specification	See Wiring Specifications for Removable Terminal Blocks in the PointMax I/O System Specifications Technical Data, publication 5034-TD001
Indicators	1 green/red module status indicator 1 green/red SA power status indicator 8 yellow/red I/O status indicators
Dimensions (HxWxD), approx	123.6 x 15.0 x 66.4 mm (4.87 x 0.59 x 2.61 in.)

Table 17. General Specifications - 5034-0B8, 5034-0B8XT (continued)

Attribute	5034-0B8, 5034-0B8XT
Weight, approx	43.0 g (1.52 oz.) - 5034-0B8 45.0 g (1.59 oz.) - 5034-0B8XT
Enclosure type	None (Open-style)
North American temp code	T4
UKEX/ATEX temp code	T4
IECEx temp code	T4

(1) Value is measured at 60 °C (140 °F). Power dissipation varies with temperature.

(2) Use this Conductor Category information for planning conductor routing. See the Industrial Automation Wiring and Grounding Guidelines, publication [1770-4.1](#). Use this Conductor Category information for planning conductor routing as described in the appropriate System Level Installation Manual.

5034-0B4 and 5034-0B4XT Digital 4 Output 2 A Modules

Figure 18. 5034-0B4 and 5034-0B4XT Wiring Diagram

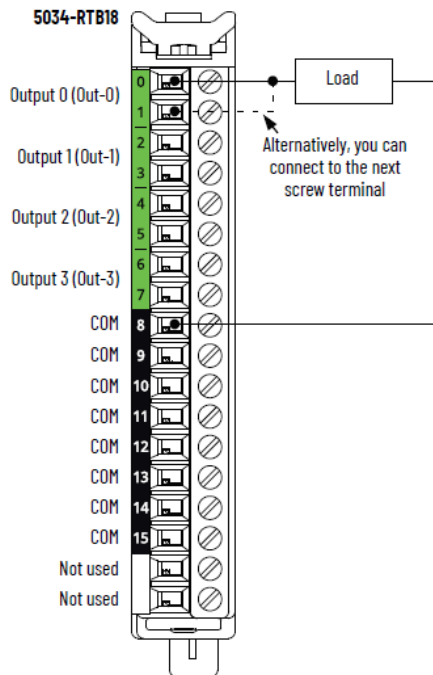

Figure 19. 5034-0B4 and 5034-0B4XT Functional Block Diagram

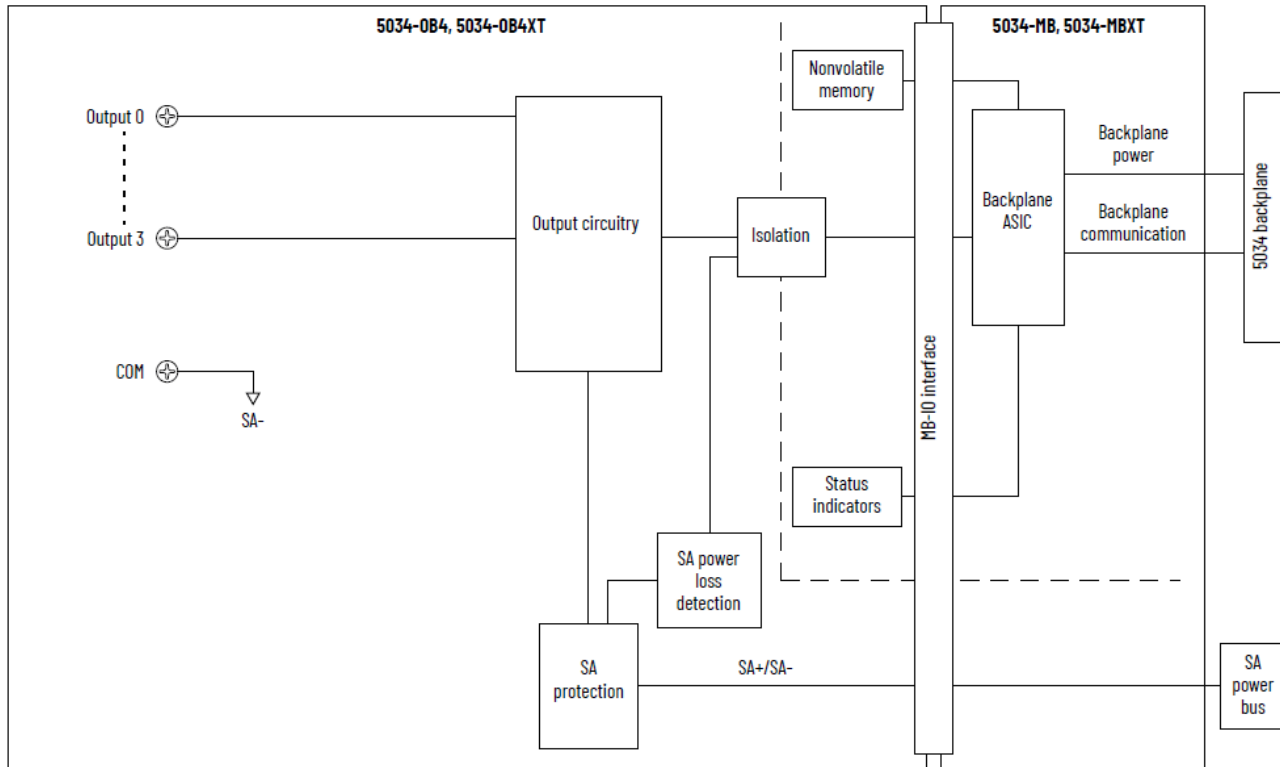

Table 18. Technical Specifications - 5034-0B4, 5034-0B4XT

Attribute	5034-0B4, 5034-0B4XT
On-state voltage range	10...30V DC
On-state voltage drop, max	0.25V DC
On-state current per point, min	1 mA
Off-state voltage, max	5V DC with 1 mA min load
Off-state open wire detection disabled	
Off-state voltage, max	5V DC with 5 mA min load
Off-state open wire detection enabled	
Off-state leakage current per point, max	0.05 mA
Off-state open wire detection disabled	
Off-state leakage current per point, max ⁽¹⁾	0.5 mA
Off-state open wire detection enabled	
Output current rating per point, max	2 A
Output current rating per module, max	6 A
Surge current per point, max	3.0 A for 10 ms, repeatable every 3 s

Table 18. Technical Specifications - 5034-0B4, 5034-0B4XT (continued)

Attribute	5034-0B4, 5034-0B4XT
Fast inductive load turn-off	Yes
Inductive load allowed, max	1.2 H
Output clamping voltage for inductive load when turn off	SA voltage - 44V Typical is -20V when SA voltage is 24V
Output delay time (backplane to screw), max Off-to-On On-to-Off	200 μ s @ 2 A
Pulse width, min	200 μ s
Open load detection diagnostics	Yes, configurable (Default is off)
Output short circuit/overload detection	Yes
Output short circuit/overload protection	Yes
Pilot duty rating	3 A inrush current, 2 A rated current, DC-14
Output states in program mode per point	Hold Last State On Off (Default)
Output states in fault mode per point	Hold Last State On Off (Default)
Duration of fault mode per point	1 s 2 s 5 s 10 s Forever (Default)
Output final state after fault mode per point	On Off (Default)
Scheduled outputs	Not supported

(1) Recommended Loading Resistor - To limit the effects of leakage current through solid-state outputs, you can connect a loading resistor in parallel with your load. For 24V DC operation, use a 5.6 k Ω , 0.5 W resistor for transistor operation.

Table 19. General Specifications - 5034-0B4, 5034-0B4XT

Attribute	5034-0B4, 5034-0B4XT
Number of outputs	4 channels (1 group of 4), sourcing
Voltage category	24V DC source
Output voltage, nom	24V DC
Output voltage range	10...30V DC
SA power voltage, nom	24V DC
SA power voltage range	10...30V DC
SA power current, nom	6.1 A
SA power current, max	6.2 A
SA power current at no load	9 mA
SA reverse polarity protection	Yes
Power dissipation, max ⁽¹⁾	1.88 W
Thermal dissipation, max ⁽¹⁾	6.41 BTU/hr
Isolation voltage	250V (continuous), Basic Insulation Type, System to Field No isolation between SA power and outputs No isolation between individual outputs
RIUP support	Yes
CIP Sync	Slave only ordinary clock
Electronic keying	Electronic keying via programming software
RTB key positions (slot)	1, 7, 11
RTB supported	5034-RTB18, 5034-RTB18S
Wiring category ⁽²⁾	2 - Signal ports 2 - Power ports
Wiring specification	See Wiring Specifications for Removable Terminal Blocks in the PointMax I/O System Specifications Technical Data, publication 5034-TD001
Indicators	1 green/red module status indicator 1 green/red SA power status indicator 4 yellow/red I/O status indicators
Dimensions (HxWxD), approx	123.6 x 15.0 x 66.4 mm (4.87 x 0.59 x 2.61 in.)

Table 19. General Specifications - 5034-0B4, 5034-0B4XT (continued)

Attribute	5034-0B4, 5034-0B4XT
Weight, approx	45.0 g (1.59 oz.) - 5034-0B4 47.0 g (1.66 oz.) - 5034-0B4XT
Enclosure type	None (Open-style)
North American temp code	T4
UKEX/ATEX temp code	T4
IECEx temp code	T4

(1) Value is measured at 60 °C (140 °F). Power dissipation varies with temperature.

(2) Use this Conductor Category information for planning conductor routing. See the Industrial Automation Wiring and Grounding Guidelines, publication [1770-4.1](#). Use this Conductor Category information for planning conductor routing as described in the appropriate System Level Installation Manual.

5034-0W4I and 5034-0W4IXT Relay 4 Output Isolated 2 A Modules

Figure 20. 5034-0W4I and 5034-0W4IXT Wiring Diagram

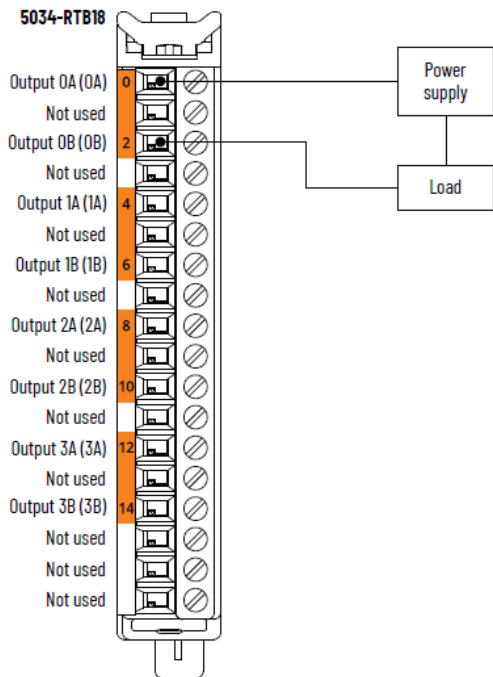

Figure 21. 5034-0W4I and 5034-0W4IXT Functional Block Diagram

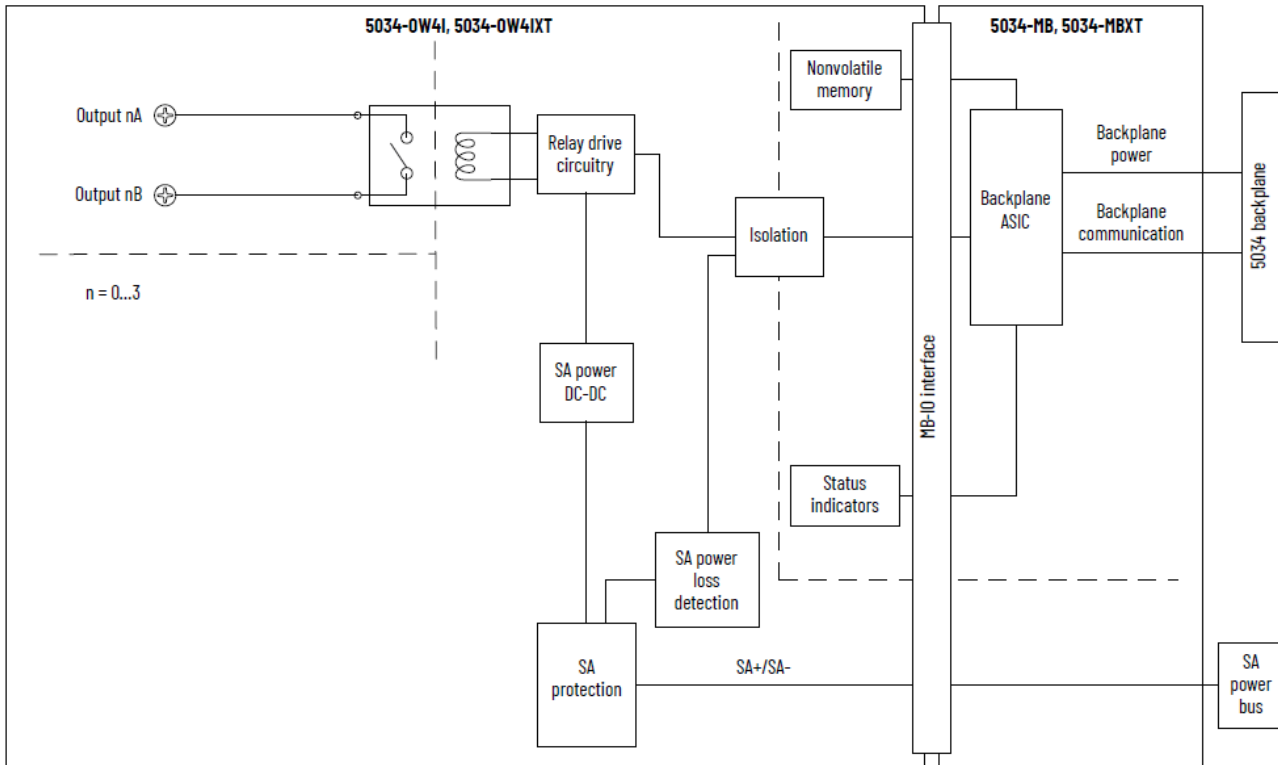

Table 20. Technical Specifications - 5034-0W4I, 5034-0W4IXT

Attribute	5034-0W4I, 5034-0W4IXT
Relay rating ⁽¹⁾	2 A resistive/channel @ 5...30V DC 2 A resistive/channel @ 120V AC, 50/60 Hz 2 A resistive/channel @ 240V AC, 50/60 Hz
Off-state leakage	0 mA Dry contact, no onboard snubbers
Output current rating, max	2 A resistive/channel @ 5...30V DC 2 A resistive/channel @ 120V AC, 50/60 Hz 2 A resistive/channel @ 240V AC, 50/60 Hz
Output delay time (backplane to screw), max Off-to-On On-to-Off	10 ms
Initial contact resistance, max	30 mΩ
Output states in program mode per point	Hold Last State On Off (Default)

Table 20. Technical Specifications - 5034-0W4I, 5034-0W4IXT (continued)

Attribute	5034-0W4I, 5034-0W4IXT
Output states in fault mode per point	Hold Last State On Off (Default)
Duration of fault mode per point	1 s 2 s 5 s 10 s Forever (Default)
Output final state after fault mode per point	On Off (Default)
On-state current per point, min	100 µA @ 100 mV DC
Switching frequency, max	1 operation/3 sec (0.3 Hz @ rated load)
Expected contact life, electrical	2 A, 240V AC (resistive): Min 1x10 ⁵ operating cycles (@ 20 times/min) 2 A, 30V DC (resistive): Min 1x10 ⁵ operating cycles (@ 20 times/min)
Expected contact life, mechanical	Min 2x10 ⁷ operating cycles (@ 180 times/min)
Pilot duty rating	5...240V AC, 50/60 Hz, C300 pilot duty per channel 5...125V DC, R150 pilot duty per channel

(1) Surge Suppression - Connecting surge suppressors across your external inductive load extends the life of the module. For additional details, see the Industrial Automation Wiring and Grounding Guidelines, publication [1770-4.1](#).

Table 21. General Specifications - 5034-0W4I, 5034-0W4IXT

Attribute	5034-0W4I, 5034-0W4IXT
Number of outputs	4 Form A (normally open)
Output voltage range	5...30V DC 5...240V AC
SA power voltage, nom	24V DC
SA power voltage range	10...30V DC
SA power current, nom	100 mA
SA power current, max	200 mA
SA power current at no load	3.0 mA

Table 21. General Specifications - 5034-0W4I, 5034-0W4IXT (continued)

Attribute	5034-0W4I, 5034-0W4IXT
SA reverse polarity protection	Yes
Power dissipation, max ⁽¹⁾	0.74 W
Thermal dissipation, max ⁽¹⁾	2.52 BTU/hr
Isolation voltage	250V (continuous), Basic Insulation Type, System to SA 250V (continuous), Reinforced Insulation Type, System to Channel 250V (continuous), Reinforced Insulation Type, SA to Channel 250V (continuous), Reinforced Insulation Type, Channel to Channel
RIUP support	Yes
Electronic keying	Electronic keying via programming software
RTB key positions (slot)	7, 12, 15
RTB supported	5034-RTB18, 5034-RTB18S
Wiring category ⁽²⁾	2 - Signal ports 2 - Power ports
Wiring specification	See Wiring Specifications for Removable Terminal Blocks in the PointMax I/O System Specifications Technical Data, publication 5034-TD001
Indicators	1 green/red module status indicator 1 green/red SA power status indicator 4 yellow I/O status indicators
Dimensions (HxWxD), approx	123.6 x 15.0 x 66.4 mm (4.87 x 0.59 x 2.61 in.)
Weight, approx	53.0 g (1.87 oz.) - 5034-0W4I 55.0 g (1.94 oz.) - 5034-0W4IXT
Enclosure type	None (Open-style)
North American temp code	T4
UKEX/ATEX temp code	T4
IECEx temp code	T4

(1) Value is measured at 60 °C (140 °F). Power dissipation varies with temperature.

(2) Use this Conductor Category information for planning conductor routing. See the Industrial Automation Wiring and Grounding Guidelines, publication [1770-4.1](#). Use this Conductor Category information for planning conductor routing as described in the appropriate System Level Installation Manual.

5034-UB8 and 5034-UB8XT Digital 8 Input/Output Modules

Figure 22. 5034-UB8 and 5034-UB8XT Wiring Diagram - Output Mode

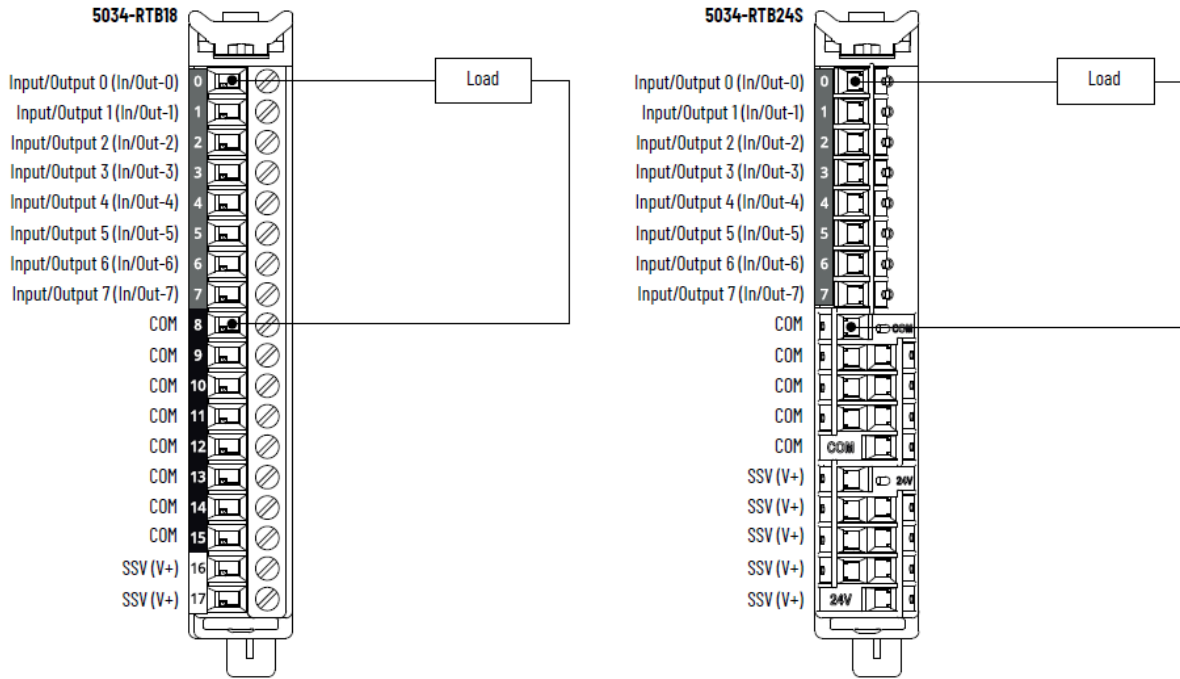
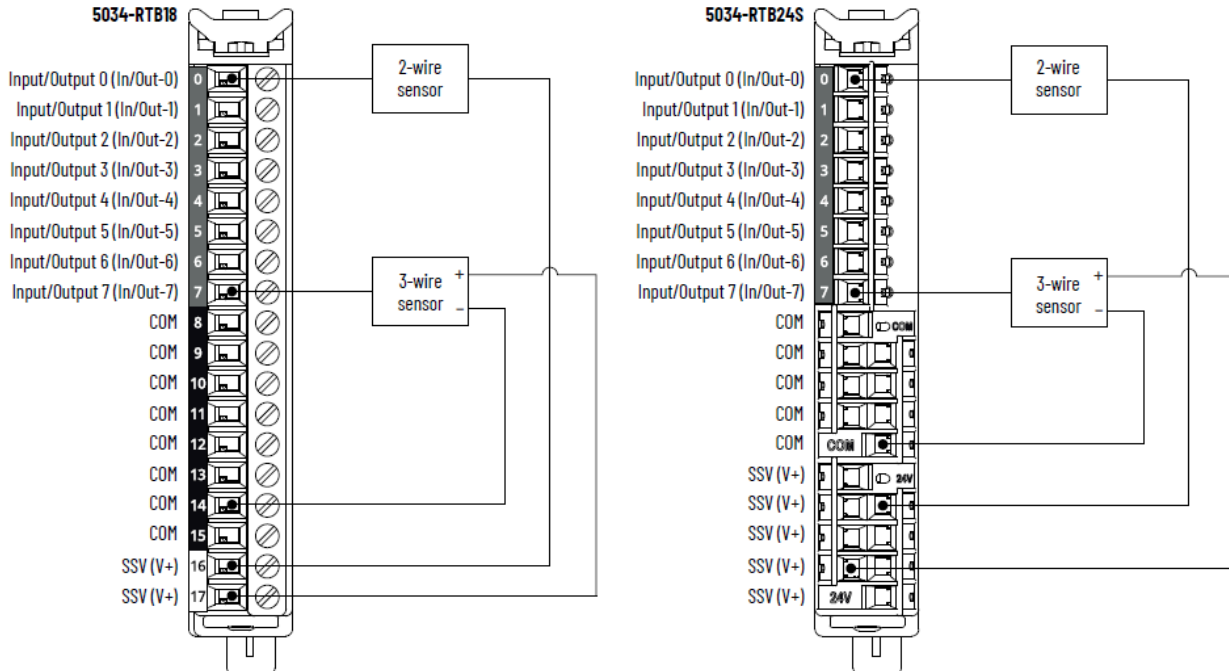

Figure 23. 5034-UB8 and 5034-UB8XT Wiring Diagram - Input Mode



To establish more COM/V+ connections, especially in a mixed input/output configuration, use a 5034-RTB24S, or install a 5034-MBPTM or 5034-MBPTMXT next to the module.

Use SSV (V+) only for powering sensors that are interfaced with a point that is configured as a digital input mode.

Figure 24. 5034-UB8 and 5034-UB8XT Functional Block Diagram

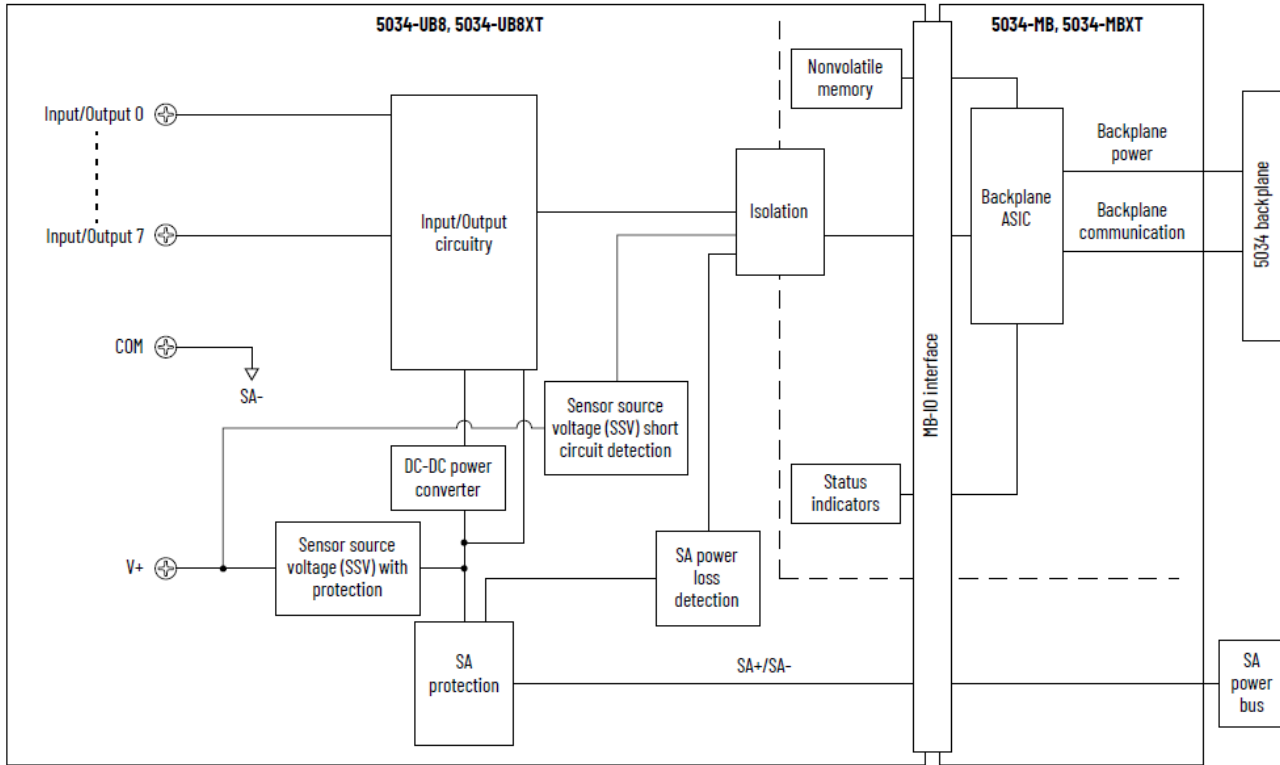

Table 22. Technical Specifications - 5034-UB8, 5034-UB8XT - Input

Attribute	5034-UB8, 5034-UB8XT
On-state voltage range	10...30V DC
On-state current, min	2 mA
On-state current, nom	4.5 mA
On-state current, max	5 mA
Off-state voltage, max	5V DC
Off-state current, max	1.5 mA
Input impedance, min	2 kΩ @ 10V DC
Input impedance, nom	5.3 kΩ @ 24V DC
Input impedance, max	15 kΩ @ 30V DC
Input delay time (screw to backplane), max	250 μs
Off-to-On	
On-to-Off	
Input pulse width, min	250 μs
Off-to-On	

Table 22. Technical Specifications - 5034-UB8, 5034-UB8XT - Input (continued)

Attribute	5034-UB8, 5034-UB8XT
On-to-Off	
Input filter time	0 μ s, 500 μ s, 1 ms (Default), 2 ms, 5 ms, 10 ms, 20 ms, 50 ms
Off-to-On	
On-to-Off	
Simple counters, counter frequency	0... f_{max} = 2000 Hz
Timestamp of inputs (sequence of events)	Yes, \pm 200 μ s accuracy
Events	Not supported

Table 23. Technical Specifications - 5034-UB8, 5034-UB8XT - Output

Attribute	5034-UB8, 5034-UB8XT
On-state voltage range	10...30V DC
On-state voltage drop, max	0.25V DC
On-state current per point, min	1.0 mA
Off-state voltage, max	5V DC with 1 mA min load
Off-state open wire detection disabled	
Off-state voltage, max	5V DC with 5 mA min load
Off-state open wire detection enabled	
Off-state leakage current per point, max	0.1 mA
Off-state open wire detection disabled	
Off-state leakage current per point, max ⁽¹⁾	0.5 mA
Off-state open wire detection enabled	
Output current rating per point, max	0.5 A
Output current rating per module, max	4 A
Surge current per point, max	1.2 A for 10 ms, repeatable every 3 s
Inductive load allowed, max	1.2 H
Output clamping voltage for inductive load when turn off	(SA voltage + VCL)...0 VCL value: Minimum is -63V, Typical is -55V, Maximum is -49V For more information, see the PointMax Digital I/O Modules User Manual, publication 5034-UM002 .
Output delay time (backplane to screw), max	150 μ s @ 0.5 A
Off-to-On	

Table 23. Technical Specifications - 5034-UB8, 5034-UB8XT - Output (continued)

Attribute	5034-UB8, 5034-UB8XT
On-to-Off	
Pulse width, min	200 μ s
Scheduled outputs	Supported, accuracy \pm 100 μ s
Open load detection diagnostics	Yes, configurable (Default is off)
Output short circuit/overload detection	Yes
Output short circuit/overload protection	Yes
Pilot duty rating	1.2 A inrush current, 0.5 A rated current, DC-14
Output states in program mode per point	Hold Last State On Off (Default)
Output states in fault mode per point	Hold Last State On Off (Default)
Duration of fault mode per point	1 s 2 s 5 s 10 s Forever (Default)
Output final state after fault mode per point	On Off (Default)

(1) Recommended Loading Resistor - To limit the effects of leakage current through solid-state outputs, you can connect a loading resistor in parallel with your load. For 24V DC operation, use a 5.6 k Ω , 0.5 W resistor for transistor operation.

Table 24. General Specifications - 5034-UB8, 5034-UB8XT

Attribute	5034-UB8, 5034-UB8XT
Number of inputs/outputs	8 channels, configurable, sinking input, sourcing output
SA power voltage, nom	24V DC
SA power voltage range	10...30V DC
SA power current, nom	4.1 A
SA power current, max	4.2 A

Table 24. General Specifications - 5034-UB8, 5034-UB8XT (continued)

Attribute	5034-UB8, 5034-UB8XT
SA power current at no load	14 mA
SA reverse polarity protection	Yes
SSV voltage range	Follow SA supply
SSV current, max	0.8 A
SSV short-circuit detection	Yes
Power dissipation, max ⁽¹⁾	1.36 W
Thermal dissipation, max ⁽¹⁾	4.63 BTU/hr
Isolation voltage	250V (continuous), Basic Insulation Type, System to Field No isolation between SA power and input/output ports No isolation between individual input/output ports
RIUP support	Yes
CIP Sync	Slave only ordinary clock
Electronic keying	Electronic keying via programming software
RTB key positions (slot)	1, 5, 8
RTB supported	5034-RTB18, 5034-RTB18S, 5034-RTB24S
Wiring category ⁽²⁾	2 - Signal ports 2 - Power ports
Wiring specification	See Wiring Specifications for Removable Terminal Blocks in the PointMax I/O System Specifications Technical Data, publication 5034-TD001
Indicators	1 green/red module status indicator 1 green/red SA power status indicator 8 yellow/red I/O status indicators
Dimensions (HxWxD), approx	123.6 x 15.0 x 66.4 mm (4.87 x 0.59 x 2.61 in.)
Weight, approx	45.0 g (1.59 oz.) - 5034-UB8 47.0 g (1.66 oz.) - 5034-UB8XT
Enclosure type	None (Open-style)
North American temp code	T4
UKEX/ATEX temp code	T4

Table 24. General Specifications - 5034-UB8, 5034-UB8XT (continued)

Attribute	5034-UB8, 5034-UB8XT
IECEx temp code	T4

(1) Value is measured at 60 °C (140 °F). Power dissipation varies with temperature.

(2) Use this Conductor Category information for planning conductor routing. See the Industrial Automation Wiring and Grounding Guidelines, publication [1770-4.1](#). Use this Conductor Category information for planning conductor routing as described in the appropriate System Level Installation Manual.

5034-UB8F and 5034-UB8FXT Fast Digital 8 Input/Output Modules

Figure 25. 5034-UB8F and 5034-UB8FXT Wiring Diagram - Output Mode

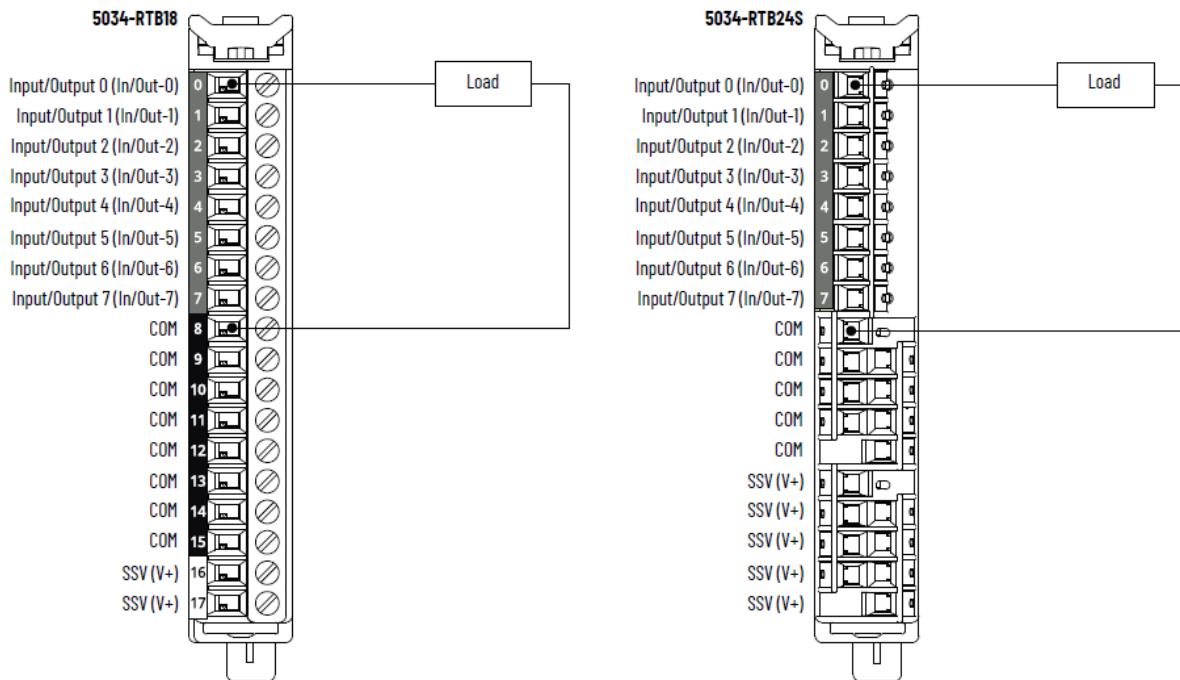
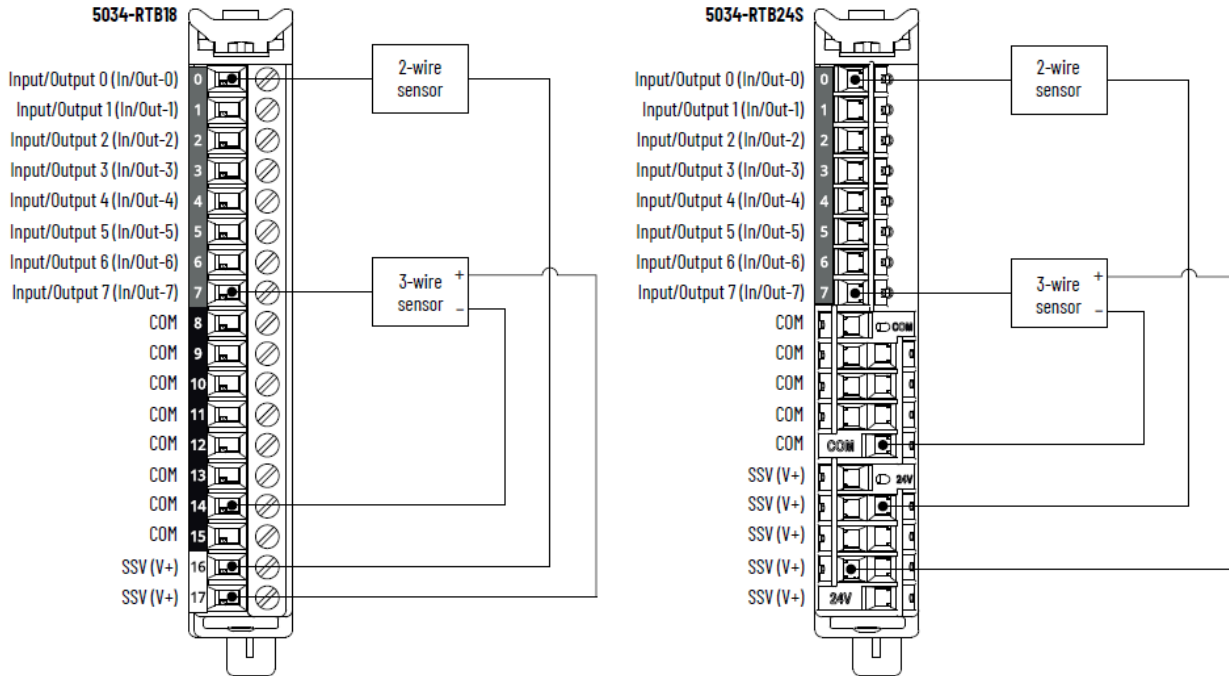

Figure 26. 5034-UB8F and 5034-UB8FXT Wiring Diagram - Input Mode



To establish more COM/V+ connections, especially in a mixed input/output configuration, use a 5034-RTB24S, or install a 5034-MBPTM or 5034-MBPTMXT next to the module.

Use SSV (V+) only for powering sensors that are interfaced with a point that is configured as a digital input mode.

Figure 27. 5034-UB8F and 5034-UB8FXT Functional Block Diagram

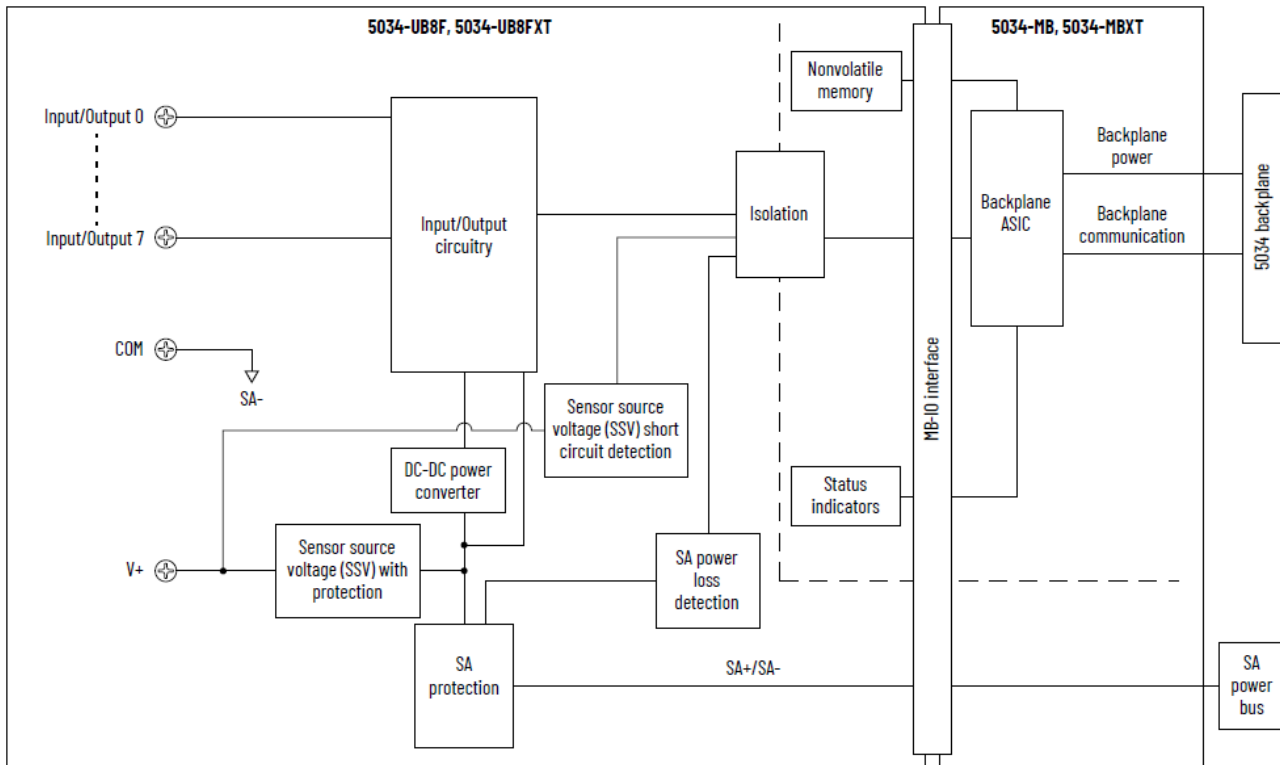

Table 25. Technical Specifications - 5034-UB8F, 5034-UB8FXT - Input

Attribute	5034-UB8F, 5034-UB8FXT
On-state voltage range	10...30V DC
On-state current, min	2 mA
On-state current, nom	4.5 mA
On-state current, max	5 mA
Off-state voltage, max	5V DC
Off-state current, max	1.5 mA
Input impedance, min	2 kΩ @ 10V DC
Input impedance, nom	5.3 kΩ @ 24V DC
Input impedance, max	15 kΩ @ 30V DC
Input delay time (screw to backplane), max Off-to-On On-to-Off	40 μs
Input pulse width, min Off-to-On On-to-Off	10 μs
Input filter time Off-to-On On-to-Off	0 μs (Default), 5 μs, 10 μs, 20 μs, 50 μs, 100 μs, 200 μs, 500 μs, 1 ms, 2 ms, 5 ms, 10 ms, 20 ms, 50 ms
Simple counters, counter frequency	0...f _{max} = 50,000 Hz
Per point timestamp of inputs (sequence of events)	Yes, ±10 μs accuracy
FIFO timestamp of inputs (sequence of events)	Yes
Events	Yes

Table 26. Technical Specifications - 5034-UB8F, 5034-UB8FXT - Output

Attribute	5034-UB8F, 5034-UB8FXT
On-state voltage range	10...30V DC
On-state voltage drop, max	0.25V DC
On-state current per point, min	1.0 mA

Table 26. Technical Specifications - 5034-UB8F, 5034-UB8FXT - Output (continued)

Attribute	5034-UB8F, 5034-UB8FXT
Off-state voltage, max	5V DC with 1 mA min load
Off-state leakage current per point, max ⁽¹⁾	0.5 mA
Output current rating per point, max	0.5 A
Output current rating per module, max	4 A
Surge current per point, max	1.2 A for 10 ms, repeatable every 3 s
Inductive load allowed, max	1.2 H
Output clamping voltage for inductive load when turn off	(SA voltage + VCL)...0 VCL value: Minimum is -63V, Typical is -55V, Maximum is -49V For more information, see the PointMax Digital I/O Modules User Manual, publication 5034-UM002 .
Output delay time (backplane to screw), max Off-to-On On-to-Off	20 µs @ 0.5 A
Pulse width, min	20 µs
Scheduled outputs	Supported, accuracy ±10 µs
PWM/PTO support	Yes Maximum switching frequency: 100 kHz (10 µs period) Minimum switching frequency: 0.033 Hz (30 s period) Minimum pulse width: 5 µs Maximum load current (resistive type) per point: <ul style="list-style-type: none"> • 200 mA for $F_{sw} \leq 10$ kHz • 100 mA for $10 \text{ kHz} < F_{sw} \leq 25$ kHz • 40 mA for $25 \text{ kHz} < F_{sw} \leq 100$ kHz Where F_{sw} is the switching frequency
Logic controlled output support	Yes
Triggered pulse output support	Yes
Open load detection diagnostics	Not supported
Output short circuit/overload detection	Yes
Output short circuit/overload protection	Yes
Pilot duty rating	1.2 A inrush current, 0.5 A rated current, DC-14
Output states in program mode per point	Hold Last State

Table 26. Technical Specifications - 5034-UB8F, 5034-UB8FXT - Output (continued)

Attribute	5034-UB8F, 5034-UB8FXT
	On Off (Default) Local Control
Output states in fault mode per point	Hold Last State On Off (Default) Local Control
Duration of fault mode per point	1 s 2 s 5 s 10 s Forever (Default)
Output final state after fault mode per point	On Off (Default)

(1) Recommended Loading Resistor - To limit the effects of leakage current through solid-state outputs, you can connect a loading resistor in parallel with your load. For 24V DC operation, use a 5.6 kΩ, 0.5 W resistor for transistor operation.

Table 27. General Specifications - 5034-UB8F, 5034-UB8FXT

Attribute	5034-UB8F, 5034-UB8FXT
Number of inputs/outputs	8 channels, configurable, sinking input, sourcing output
SA power voltage, nom	24V DC
SA power voltage range	10...30V DC
SA power current, nom	4.1 A
SA power current, max	4.2 A
SA power current at no load	14.3 mA
SA reverse polarity protection	Yes
SSV voltage range	Follow SA supply
SSV current, max	0.8 A
SSV short-circuit detection	Yes
Power dissipation, max ⁽¹⁾	1.43 W

Table 27. General Specifications - 5034-UB8F, 5034-UB8FXT (continued)

Attribute	5034-UB8F, 5034-UB8FXT
Thermal dissipation, max ⁽¹⁾	4.87 BTU/hr
Isolation voltage	250V (continuous), Basic Insulation Type, System to Field No isolation between SA power and input/output ports No isolation between individual input/output ports
RIUP support	Yes
CIP Sync	Slave only ordinary clock
Electronic keying	Electronic keying via programming software
RTB key positions (slot)	1, 5, 8
RTB supported	5034-RTB18, 5034-RTB18S, 5034-RTB24S
Wiring category ⁽²⁾	2 - Signal ports 2 - Power ports
Wiring specification	See Wiring Specifications for Removable Terminal Blocks in the PointMax I/O System Specifications Technical Data, publication 5034-TD001
Indicators	1 green/red module status indicator 1 green/red SA power status indicator 8 yellow/red I/O status indicators
Dimensions (HxWxD), approx	123.6 x 15.0 x 66.4 mm (4.87 x 0.59 x 2.61 in.)
Weight, approx	45.0 g (1.59 oz.) - 5034-UB8F 47.0 g (1.66 oz.) - 5034-UB8FXT
Enclosure type	None (Open-style)
North American temp code	T4
UKEX/ATEX temp code	T4
IECEx temp code	T4

(1) Value is measured at 60 °C (140 °F). Power dissipation varies with temperature.

(2) Use this Conductor Category information for planning conductor routing. See the Industrial Automation Wiring and Grounding Guidelines, publication [1770-4.1](#). Use this Conductor Category information for planning conductor routing as described in the appropriate System Level Installation Manual.

Environmental Specifications and Certifications

The following tables provide the environmental specifications and certifications for the PointMax digital I/O modules.

Table 28. Environmental Specifications - PointMax Digital I/O Modules

Attribute	5034-IB16, 5034-IB8, 5034-OB16, 5034-OB8, 5034-OB4, 5034-OW4I, 5034-UB8, 5034-UB8F	5034-IB16XT, 5034-IB8XT, 5034-OB16XT, 5034-OB8XT, 5034-OB4XT, 5034-OW4IXT, 5034-UB8XT, 5034-UB8FXT
Temperature, operating	IEC 60068-2-1 (Test Ae, Operating Cold), IEC 60068-2-2 (Test Be, Operating Dry Heat), IEC 60068-2-14 (Test Nb, Operating Thermal Shock): -25 °C ≤ Ta ≤ +60 °C (-13 °F ≤ Ta ≤ +140 °F) for horizontal orientation -25 °C ≤ Ta ≤ +55 °C (-13 °F ≤ Ta ≤ +131 °F) for other orientations	
Temperature, surrounding air, max	60 °C (140 °F)	
Temperature, nonoperating	IEC 60068-2-1 (Test Ab, Unpackaged Nonoperating Cold), IEC 60068-2-2 (Test Bb, Unpackaged Nonoperating Dry Heat), IEC 60068-2-14 (Test Na, Unpackaged Nonoperating Thermal Shock): -40...+85 °C (-40...+185 °F)	
Relative humidity	IEC 60068-2-30 (Test Db, Unpackaged Damp Heat): 5...95% noncondensing	
Conformal coated	No	Yes
Corrosive Atmosphere ASTM B845-97 Method K Accelerated Test (20-Day Exposure)	Severity Level G3 ⁽¹⁾ per ANSI/ISA 71.04-2013, Airborne Contaminants—Gases	—
Corrosive Atmosphere <ul style="list-style-type: none"> • ASTM B845-97 Method K Accelerated Test (30-Day Exposure) • Plus additional Rockwell Automation proprietary accelerated corrosive environment test protocol for specific industries with sources of gaseous sulfur compounds. 	—	Severity Level GX ⁽²⁾ per ANSI/ISA 71.04-2013, Airborne Contaminants—Gases Severity Level CX per IEC 60721-3-3:2019, Chemically Active Substances
Vibration	IEC 60068-2-6 (Test Fc, Operating): 5 g @ 10...500 Hz	
Shock, operating	IEC 60068-2-27 (Test Ea, Unpackaged Shock):	

Table 28. Environmental Specifications - PointMax Digital I/O Modules (continued)

Attribute	5034-IB16, 5034-IB8, 5034-OB16, 5034-OB8, 5034-OB4, 5034-OW4I, 5034-UB8, 5034-UB8F	5034-IB16XT, 5034-IB8XT, 5034-OB16XT, 5034-OB8XT, 5034-OB4XT, 5034-OW4IXT, 5034-UB8XT, 5034-UB8FXT
	30 g	
Repetitive shock, operating	IEC 60068-2-27: 25 g, 6 ms duration, 1000 shocks in each ± direction in each 3 axis	
Shock, nonoperating	IEC 60068-2-27 (Test Ea, Unpackaged Shock): 50 g	
Emissions	IEC 61000-6-4	
ESD immunity	IEC 61000-4-2: 6 kV contact discharges 8 kV air discharges	
Radiated RF immunity	IEC 61000-4-3: 10V/m with 1 kHz sine wave 80% AM from 80...2000 MHz 10V/m with 1 kHz sine wave 80% AM from 2000...2700 MHz 10V/m with 1 kHz sine wave 80% AM from 2700...6000 MHz	
EFT/B immunity	IEC 61000-4-4: ±3 kV @ 5 kHz on signal ports	
Surge transient immunity	IEC 61000-4-5: ±1 kV line-line (DM) and ±2 kV line-earth (CM) on signal ports	
Conducted RF immunity	IEC 61000-4-6: 10V rms with 1 kHz sine wave 80% AM from 150 kHz...80 MHz	

(1) Up to 86.4 g/(m2.yr), mass loss of copper due to corrosion.

(1) Up to 2100 angstroms of film growth per 30 days of copper and/or silver reactivity.

Table 29. Certifications - PointMax Digital I/O Modules

Certification ⁽¹⁾	5034-IB16, 5034-IB16XT, 5034-IB8, 5034-IB8XT, 5034-OB16, 5034-OB16XT, 5034-OB8, 5034-OB8XT, 5034-OB4, 5034-OB4XT, 5034-OW4I, 5034-OW4IXT, 5034-UB8, 5034-UB8XT, 5034-UB8F, 5034-UB8FXT
c-UL-us	UL Listed Industrial Control Equipment, certified for US and Canada. See UL File E322657. UL Listed for Class I, Division 2 Group A,B,C,D Hazardous Locations, certified for U.S. and Canada. See UL File E334470.
UK and CE	UK Statutory Instrument 2016 No. 1091 and European Union 2014/30/EU EMC Directive, compliant with: EN 61326-1; Meas./Control/Lab., Industrial Requirements EN 61000-6-2; Industrial Immunity EN 61000-6-4; Industrial Emissions

Table 29. Certifications - PointMax Digital I/O Modules (continued)

<p>Certification⁽¹⁾</p>	<p>5034-IB16, 5034-IB16XT, 5034-IB8, 5034-IB8XT, 5034-OB16, 5034-OB16XT, 5034-OB8, 5034-OB8XT, 5034-OB4, 5034-OB4XT, 5034-OW4I, 5034-OW4IXT, 5034-UB8, 5034-UB8XT, 5034-UB8F, 5034-UB8FXT</p>
	<p>EN 61131-2; Programmable Controllers (Clause 8, Zone A & B) UK Statutory Instrument 2016 No. 1101 and European Union 2014/35/EU LVD, compliant with: EN 61010-2-201; Control Equipment Safety Requirements UK Statutory Instrument 2012 No. 3032 and European Union 2011/65/EU RoHS, compliant with: EN IEC 63000; Technical documentation</p>
<p>RCM</p>	<p>Australian Radiocommunications Act, compliant with: EN 61000-6-4; Industrial Emissions</p>
<p>Ex</p>	<p>UK Statutory Instrument 2016 No. 1107 and European Union 2014/34/EU ATEX Directive, compliant with: EN IEC 60079-0; General Requirements EN IEC 60079-15; Potentially Explosive Atmospheres, Protection "n" for 5034-OW4I, 5034-OW4IXT only EN IEC 60079-7; Explosive Atmospheres, Protection "e" II 3 G Ex ec IIC T4 Gc and II 3 G Ex ec nC IIC T4 Gc for 5034-OW4I and 5034-OW4IXT only UL 24 ATEX 3272X and UL24UKEX2997X</p>
<p>IECEX</p>	<p>IECEX System, compliant with: IEC 60079-0; General Requirements IEC 60079-15; Potentially Explosive Atmospheres, Protection "n" for 5034-OW4I, 5034-OW4IXT only IEC 60079-7; Explosive Atmospheres, Protection "e" II 3 G Ex ec IIC T4 Gc and II 3 G Ex ec nC IIC T4 Gc for 5034-OW4I, 5034-OW4IXT only IECEX UL 24.0066X</p>
<p>KC</p>	<p>Korean Registration of Broadcasting and Communications Equipment, compliant with: Article 58-2 of Radio Waves Act, Clause 4</p>
<p>Morocco</p>	<p>Arrêté ministériel n° 6404-15 du 1 er muharram 1437 Arrêté ministériel n° 6404-15 du 29 ramadan 1436</p>
<p>CCC</p>	<p>CNCA-C23-01 强制性产品认证实施规则 防爆电气 CNCA-C23-01 CCC Implementation Rule Explosion-Proof Electrical Products 2025122309123247</p>

(1) When marked. See the Product Certifications website at rok.auto/certifications for declarations of conformity, certificates, and other certification details.

Safety Digital I/O Modules

I/O Type	Catalog Number	Description
Safety Digital Input	5034-IB8S, 5034-IB8SXT	Safety digital 8 input
Safety Digital Output	5034-OB8S, 5034-OB8SXT	Safety digital 8 output

Environmental specifications and certifications for PointMax safety digital I/O modules are provided in [Environmental Specifications and Certifications on page 68](#).

5034-IB8S and 5034-IB8SXT Safety Digital 8 Input Modules

For more examples of wiring diagrams for 5034-IB8S and 5034-IB8SXT that can be used in functional safety applications, see the PointMax Digital I/O Modules User Manual, publication [5034-UM002](#). The wiring configuration affects the safety application level to which a PointMax safety I/O module is suitable.

Figure 28. 5034-IB8S and 5034-IB8SXT Wiring Diagram - 2-wire and 3-wire Sensor Wiring

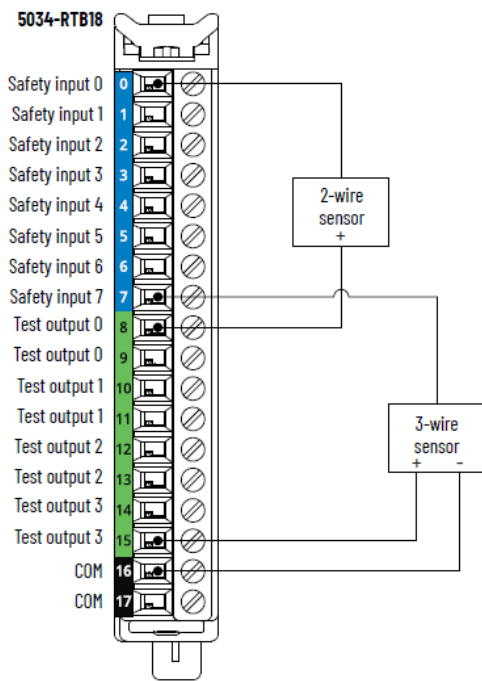

All test outputs support muting lamp outputs.

Figure 29. 5034-IB8S and 5034-IB8SXT Functional Block Diagram

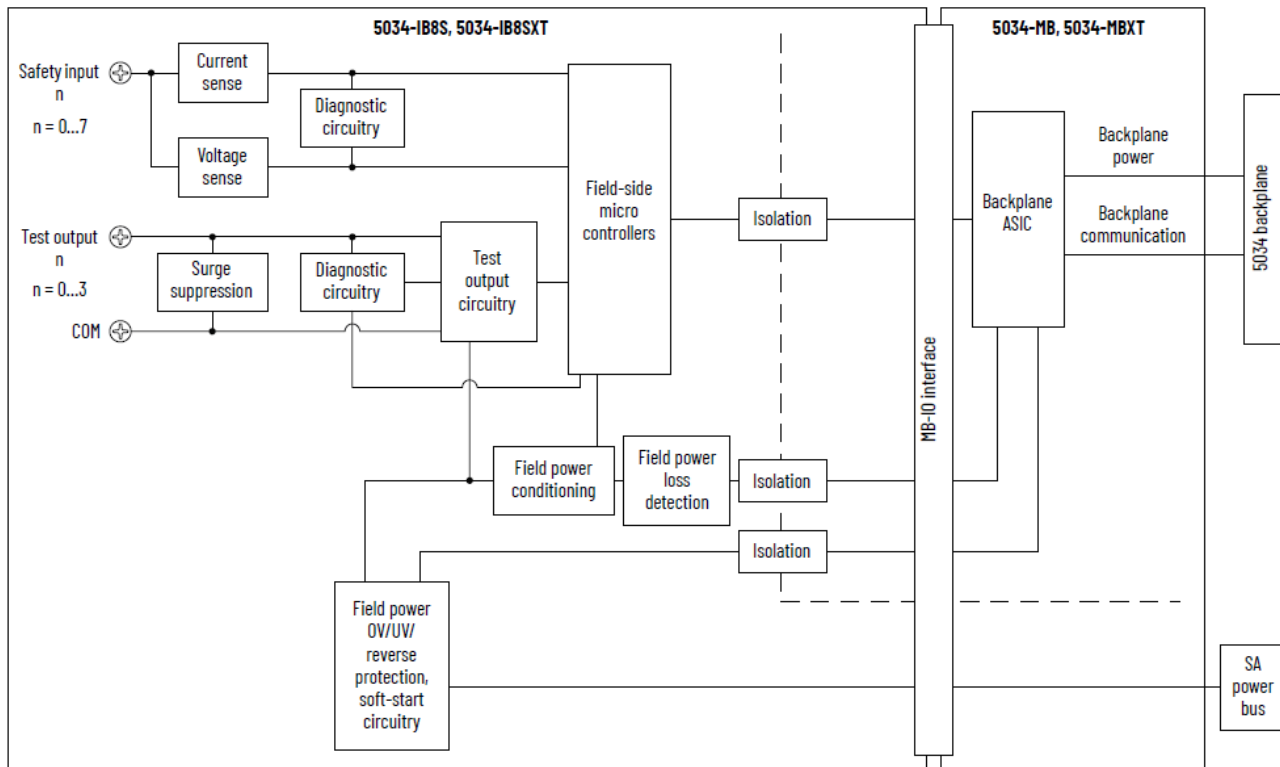

Table 30. Technical Specifications - 5034-IB8S, 5034-IB8SXT

Attribute	5034-IB8S, 5034-IB8SXT
On-state voltage range	10...30V DC
On-state current, min	2.2 mA @ 10V DC
On-state current, nom	2.4 mA @ 24V DC
On-state current, max	2.5 mA @ 30V DC
Off-state voltage, max	5V DC
Off-state current, max	1.5 mA
Input delay time	0 ms (Default), 2 ms, 5 ms, 10 ms, 20 ms, 50 ms
Off-to-On, user-selectable filter time	
Input delay time	0 ms (Default), 2 ms, 5 ms, 10 ms, 20 ms, 50 ms
On-to-Off, user-selectable filter time	
Safety class ⁽¹⁾	Up to and including Cat. 4 / PL e acc. to EN ISO 13849-1, SIL 3 acc. to IEC 61508
SRT	7 ms @ RPI of 2 ms
Test output current per point, max	0.7 A

Table 30. Technical Specifications - 5034-IB8S, 5034-IB8SXT (continued)

Attribute	5034-IB8S, 5034-IB8SXT
Test output current per module, total	2.8 A
Test output pulse width, max	0.7 ms
Test output pulse period, typical	512 ms
Test output field capacitance, max	100 nF
Surge current per test output, max	2.4 A for 50 ms, repeatable every 2 s The module current rating cannot exceed 5 A.
Test output on-state voltage drop, max	0.5V DC @ 0.7 A
Test output off-state leakage current, max	0.5 mA
Test output off-state voltage, max	5V DC
Muting lamp fault threshold current, max	6 mA
Muting lamp fault threshold current, min	1.8 mA
Test output short to ground/overload protection	Yes (per point), 4 A typical
Module over-temperature detection	Yes
SA supply reverse voltage protection	Yes
SA supply overvoltage protection, max	60V DC

(1) See the PointMax Digital I/O Modules User Manual, publication [5034-UM002](#), for Safety Application Suitability Levels and Safety Data for safety modules.

Table 31. General Specifications - 5034-IB8S, 5034-IB8SXT

Attribute	5034-IB8S, 5034-IB8SXT
Number of safety inputs	8
Input type	IEC 61131-2 (Type 3), current sinking
Number of Test outputs/Muting Lamp outputs	4
Test output type	Sourcing
SA power nominal operating supply voltage	24V DC
SA power operating voltage range	18...30V DC
SA power current, nom	2.9 A
SA power current, max	2.9 A

Table 31. General Specifications - 5034-IB8S, 5034-IB8SXT (continued)

Attribute	5034-IB8S, 5034-IB8SXT
SA power current at no load	19 mA @ 24V DC
Power dissipation, max	1.55 W
Thermal dissipation, max	5.29 BTU/hr
Isolation voltage	250V (continuous), Basic Insulation Type, System to Field No isolation between SA power and input ports No isolation between individual inputs
RIUP support	Yes
CIP Sync	Yes, slave only ordinary clock
Electronic keying	Electronic keying via programming software
RTB key positions	1, 4, 14
RTB supported	5034-RTB18, 5034-RTB18S
Wiring category ⁽²⁾	2 - Signal ports 2 - Power ports
Wiring specification	See Wiring Specifications for Removable Terminal Blocks in the PointMax I/O System Specifications Technical Data, publication 5034-TD001
Indicators	1 green/red module status indicator 1 green/red SA power status indicator 8 yellow/red I/O status indicators
Dimensions (HxWxD), approx	123.6 x 15.0 x 66.4 mm (4.87 x 0.59 x 2.61 in.)
Weight, approx	46.0 g (1.62 oz.) - 5034-IB8S 49.0 g (1.73 oz.) - 5034-IB8SXT
Enclosure type	None (Open-style)
North American temp code	T4
UKEX/ATEX temp code	T4
IECEX temp code	T4

(1) Use this Conductor Category information for planning conductor routing. See the Industrial Automation Wiring and Grounding Guidelines, publication [1770-4.1](#). Use this Conductor Category information for planning conductor routing as described in the appropriate System Level Installation Manual.

5034-OB8S and 5034-OB8SXT Safety Digital 8 Output Modules

For more examples of wiring diagrams for 5034-OB8S and 5034-OB8SXT that can be used in functional safety applications, see the PointMax Digital I/O Modules User Manual, publication [5034-UM002](#). The wiring configuration affects the safety application level to which a PointMax safety I/O module is suitable.

Figure 30. 5034-OB8S and 5034-OB8SXT Wiring Diagram

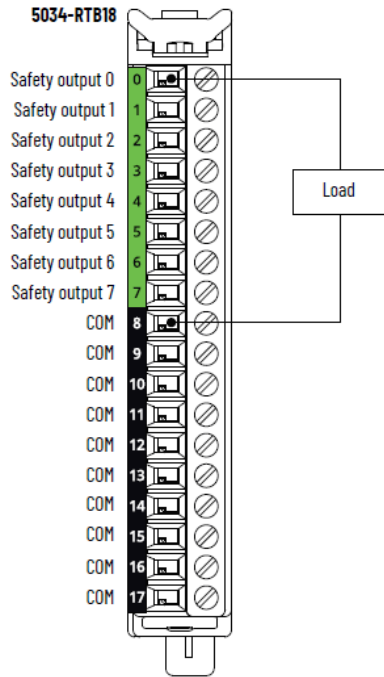

Figure 31. 5034-OB8S and 5034-OB8SXT Functional Block Diagram

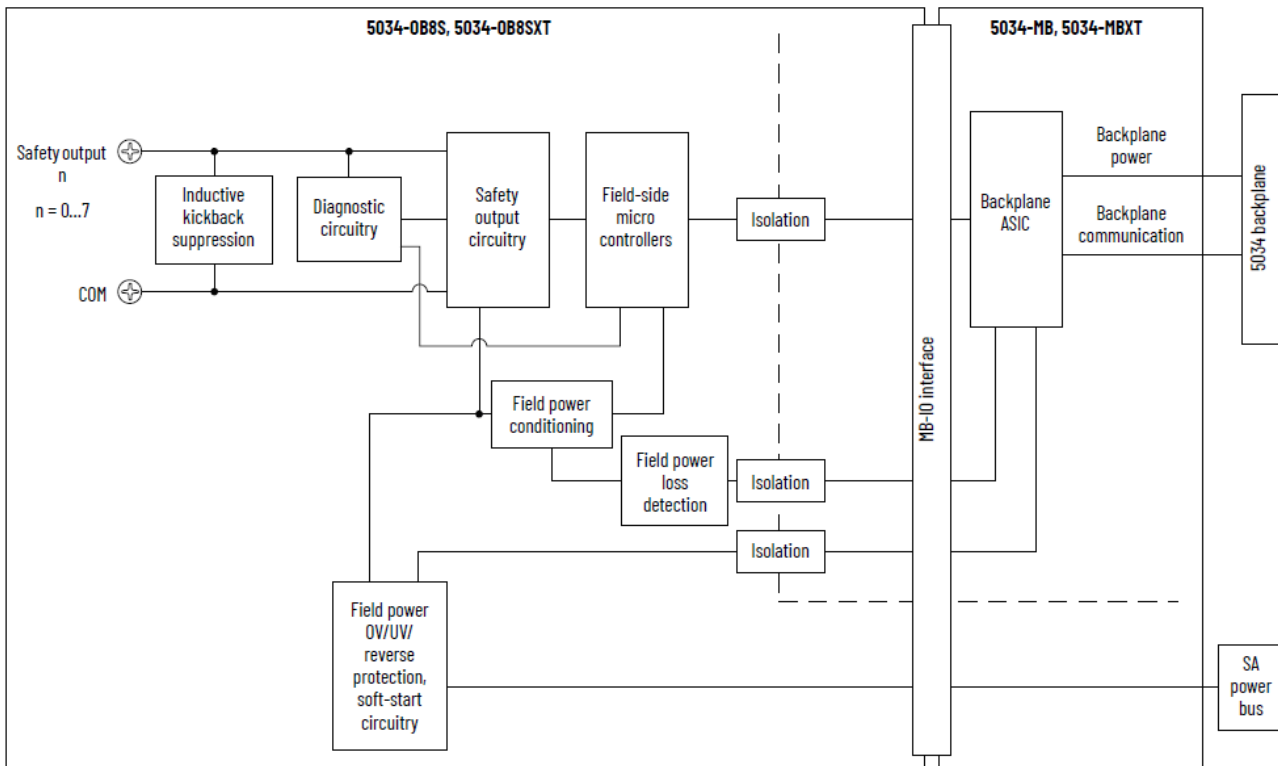

Table 32. Technical Specifications - 5034-0B8S, 5034-0B8SXT

Attribute	5034-0B8S, 5034-0B8SXT
On-state voltage range	17.5...30V DC
On-state voltage drop, max	0.5V DC @ 1 A
Off-state voltage, max	5V DC with min 10 kΩ load
Off-state leakage current per point, max	0.5 mA
Output current rating per point, max	1 A @ 40 °C (104 °F) 0.5 A @ 60 °C (140 °F)
Output current rating per module, total	8 A @ 40 °C (104 °F) 4 A @ 60 °C (140 °F)
Field capacitance limit permitted per output, max	100 nF
Field inductance limit permitted per output, max	1.2 H @ 0.5 A
Output clamping voltage for inductive load when turned off, max	53V DC
Surge current per point, max	2.4 A for 50 ms, repeatable every 2 s The module current rating cannot exceed 10 A.
Safety class ⁽¹⁾	Up to and including Cat. 4 / PL e acc. to EN ISO 13849-1, SIL 3 acc. to IEC 61508
SRT	6 ms
Safety Test Pulse width, max	0.7 ms
Safety Test Pulse period, typical	512 ms
Open load detection diagnostics	Off state (can be enabled manually)
Output overload detection	Yes, 4 A typical
Output short to high detection	Yes in Safety Pulse Test mode
Channel-to-channel short-circuit detection	Yes in Safety Pulse Test mode
Module over-temperature detection	Yes
Output short to ground/overload protection	Yes
SA supply reverse voltage protection	Yes
SA supply overvoltage protection, max	60V DC

(1) See the PointMax Digital I/O Modules User Manual, publication [5034-UM002](#), for Safety Application Suitability Levels and Safety Data for safety modules.

Table 33. General Specifications - 5034-0B8S, 5034-0B8SXT

Attribute	5034-0B8S, 5034-0B8SXT
Outputs per module	8
Output type	Sourcing
SA power nominal operating supply voltage	24V DC
SA power operating voltage range	18...30V DC
SA power current, nom	8.1 A @ 40 °C (104 °F) 4.1 A @ 60 °C (140 °F)
SA power current, max	8.1 A @ 40 °C (104 °F) 4.1 A @ 60 °C (140 °F)
SA power current at no load	20 mA @ 24V DC
Power dissipation, max	2.6 W @ 40 °C (104 °F) 1.4 W @ 60 °C (140 °F)
Thermal dissipation, max	8.87 BTU/hr @ 40 °C (104 °F) 4.78 BTU/hr @ 60 °C (140 °F)
Isolation voltage	250V (continuous), Basic Insulation Type, System to Field No isolation between SA power and output ports No isolation between individual output ports
RIUP support	Yes
CIP Sync	Yes, slave only ordinary clock
Electronic keying	Electronic keying via programming software
RTB key positions (slot)	1, 5, 14
RTB supported	5034-RTB18, 5034-RTB18S
Wiring category ⁽¹⁾	2 - Signal ports 2 - Power ports
Wiring specification	See Wiring Specifications for Removable Terminal Blocks in the PointMax I/O System Specifications Technical Data, publication 5034-TD001
Indicators	1 green/red module status indicator 1 green/red SA power status indicator 8 yellow/red I/O status indicators
Dimensions (HxWxD), approx	123.6 x 15.0 x 66.4 mm (4.87 x 0.59 x 2.61 in.)

Table 33. General Specifications - 5034-0B8S, 5034-0B8SXT (continued)

Attribute	5034-0B8S, 5034-0B8SXT
Weight, approx	46.0 g (1.62 oz.) - 5034-0B8S 49.0 g (1.73 oz.) - 5034-0B8SXT
Enclosure type	None (Open-style)
North American temp code	T4
UKEX/ATEX temp code	T4
IECEx temp code	T4

(1) Use this Conductor Category information for planning conductor routing. See the Industrial Automation Wiring and Grounding Guidelines, publication [1770-4.1](#). Use this Conductor Category information for planning conductor routing as described in the appropriate System Level Installation Manual.

Environmental Specifications and Certifications

The following tables provide the environmental specifications and certifications for the PointMax safety digital I/O modules.

Table 34. Environmental Specifications - PointMax Safety Digital I/O Modules

Attribute	5034-1B8S, 5034-0B8S	5034-1B8SXT, 5034-0B8SXT
Temperature, operating	IEC 60068-2-1 (Test Ae, Operating Cold), IEC 60068-2-2 (Test Be, Operating Dry Heat), IEC 60068-2-14 (Test Nb, Operating Thermal Shock): -25 °C ≤ Ta ≤ +60 °C (-13 °F ≤ Ta ≤ +140 °F) for horizontal orientation -25 °C ≤ Ta ≤ +55 °C (-13 °F ≤ Ta ≤ +131 °F) for other orientations	
Temperature, surrounding air, max	60 °C (140 °F)	
Temperature, nonoperating	IEC 60068-2-1 (Test Ab, Unpackaged Nonoperating Cold), IEC 60068-2-2 (Test Bb, Unpackaged Nonoperating Dry Heat), IEC 60068-2-14 (Test Na, Unpackaged Nonoperating Thermal Shock): -40...+85 °C (-40...+185 °F)	
Relative humidity	IEC 60068-2-30 (Test Db, Unpackaged Damp Heat): 5...95% noncondensing	
Conformal coated	No	Yes
Corrosive Atmosphere ASTM B845-97 Method K Accelerated Test (20-Day Exposure)	Severity Level G3 ⁽¹⁾ per ANSI/ISA 71.04-2013, Airborne Contaminants—Gases	—

Table 34. Environmental Specifications - PointMax Safety Digital I/O Modules (continued)

Attribute	5034-IB8S, 5034-OB8S	5034-IB8SXT, 5034-OB8SXT
Corrosive Atmosphere <ul style="list-style-type: none"> • ASTM B845-97 Method K Accelerated Test (30-Day Exposure) • Plus additional Rockwell Automation proprietary accelerated corrosive environment test protocol for specific industries with sources of gaseous sulfur compounds. 	–	Severity Level GX ⁽²⁾ per ANSI/ISA 71.04-2013, Airborne Contaminants—Gases Severity Level CX per IEC 60721-3-3:2019, Chemically Active Substances
Vibration	IEC 60068-2-6 (Test Fc, Operating): 5 g @ 10...500 Hz	
Shock, operating	IEC 60068-2-27 (Test Ea, Unpackaged Shock): 30 g	
Repetitive shock, operating	IEC 60068-2-27: 25 g, 6 ms duration, 1000 shocks in each ± direction in each 3 axis	
Shock, nonoperating	IEC 60068-2-27 (Test Ea, Unpackaged Shock): 50 g	
Emissions	IEC 61000-6-4	
ESD immunity	IEC 61000-4-2: 6 kV contact discharges 8 kV air discharges	
Radiated RF immunity	IEC 61000-4-3: 10V/m with 1 kHz sine wave 80% AM from 80...2000 MHz 10V/m with 1 kHz sine wave 80% AM from 2000...2700 MHz 10V/m with 1 kHz sine wave 80% AM from 2700...6000 MHz	
EFT/B immunity	IEC 61000-4-4: ±3 kV @ 5 kHz on signal ports	
Surge transient immunity	IEC 61000-4-5: ±1 kV line-line (DM) and ±2 kV line-earth (CM) on signal ports	
Conducted RF immunity	IEC 61000-4-6: 10V rms with 1 kHz sine wave 80% AM from 150 kHz...80 MHz	

(1) Up to 86.4 g/(m².yr), mass loss of copper due to corrosion.

Table 34. Environmental Specifications - PointMax Safety Digital I/O Modules (continued)

Attribute	5034-IB8S, 5034-OB8S	5034-IB8SXT, 5034-OB8SXT
-----------	----------------------	--------------------------

(2) Up to 2100 angstroms of film growth per 30 days of copper and/or silver reactivity.

Table 35. Certifications - PointMax Safety Digital I/O Modules

Certification ⁽¹⁾	5034-IB8S, 5034-IB8SXT, 5034-OB8S, 5034-OB8SXT
c-UL-us	UL Listed Industrial Control Equipment, certified for US and Canada. See UL File E322657. UL Listed for Class I, Division 2 Group A,B,C,D Hazardous Locations, certified for U.S. and Canada. See UL File E334470.
UK and CE	UK Statutory Instrument 2016 No. 1091 and European Union 2014/30/EU EMC Directive, compliant with: EN 61326-1; Meas./Control/Lab., Industrial Requirements EN 61000-6-2; Industrial Immunity EN 61000-6-4; Industrial Emissions EN 61131-2; Programmable Controllers (Clause 8, Zone A & B) UK Statutory Instrument 2016 No. 1101 and European Union 2014/35/EU LVD, compliant with: EN 61010-2-201; Control Equipment Safety Requirements UK Statutory Instrument 2012 No. 3032 and European Union 2011/65/EU RoHS, compliant with: EN IEC 63000; Technical documentation
RCM	Australian Radiocommunications Act, compliant with: EN 61000-6-4; Industrial Emissions
Ex	UK Statutory Instrument 2016 No. 1107 and European Union 2014/34/EU ATEX Directive, compliant with: EN IEC 60079-0; General Requirements EN IEC 60079-7; Explosive Atmospheres, Protection "e" II 3 G Ex ec IIC T4 Gc UL 24 ATEX 3272X and UL24UKEX2997X
IECEx	IECEx System, compliant with: IEC 60079-0; General Requirements IEC 60079-7; Explosive Atmospheres, Protection "e" II 3 G Ex ec IIC T4 Gc IECEx UL 24.0066X
TÜV ⁽²⁾	TÜV Certified for Functional Safety: Up to and including Cat. 4 / PLe according to EN ISO 13849-1 and SIL 3 according to IEC 61508
KC	Korean Registration of Broadcasting and Communications Equipment, compliant with: Article 58-2 of Radio Waves Act, Clause 4
Morocco	Arrêté ministériel n° 6404-15 du 1 er muharram 1437

Table 35. Certifications - PointMax Safety Digital I/O Modules (continued)

Certification ⁽¹⁾	5034-IB8S, 5034-IB8SXT, 5034-OB8S, 5034-OB8SXT
	Arrêté ministériel n° 6404-15 du 29 ramadan 1436
CCC	CNCA-C23-01 强制性产品认证实施规则 防爆电气 CNCA-C23-01 CCC Implementation Rule Explosion-Proof Electrical Products 2025122309123247

(1) When marked. See the Product Certifications website at rok.auto/certifications for declarations of conformity, certificates, and other certification details.

(2) When used as described in the GuardLogix® 5580 and Compact GuardLogix 5380 Controller Systems Reference Manual, publication [1756-RM012](#) and the PointMax Digital I/O Modules User Manual, publication [5034-UM002](#), for Safety Application Suitability Levels and Safety Data for safety modules.

Analog I/O Modules

I/O Type	Catalog Number	Description
Analog Input	5034-IF8C, 5034-IF8CXT	Analog 8 input current
	5034-IF8V, 5034-IF8VXT	Analog 8 input voltage
	5034-IF4, 5034-IF4XT	Analog 4 input
	5034-IF4IH, 5034-IF4IHXT	Analog 4 input isolated HART
	5034-IRT4I, 5034-IRT4IXT	Analog 4 input isolated RTD/TC
Analog Output	5034-OF4, 5034-OF4XT	Analog 4 output
	5034-OF4IH, 5034-OF4IHXT	Analog 4 output isolated HART

Environmental specifications and certifications for PointMax analog I/O modules are provided in [Environmental Specifications and Certifications on page 105](#).

5034-IF8C and 5034-IF8CXT Analog 8 Input Current Modules

Figure 32. 5034-IF8C and 5034-IF8CXT Wiring Diagram

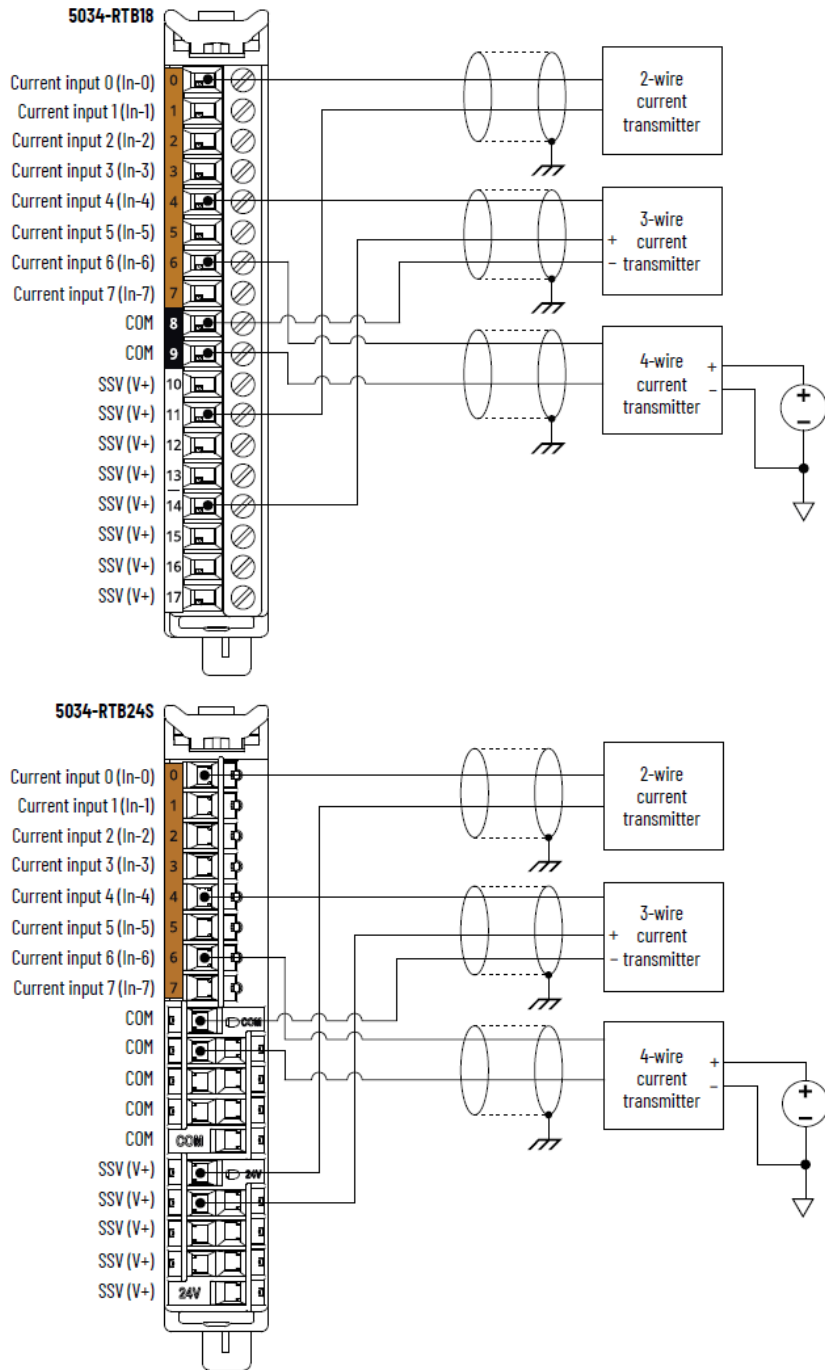

Figure 33. 5034-IF8C and 5034-IF8CXT Functional Block Diagram

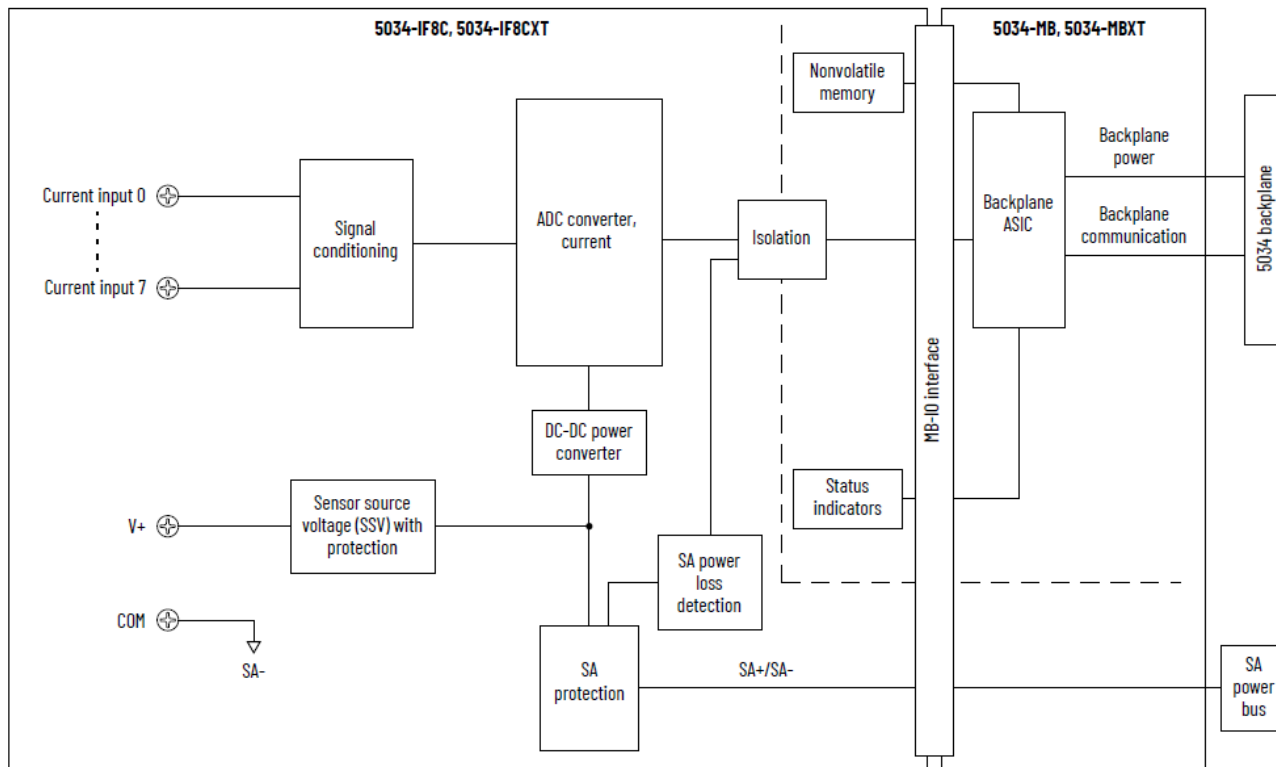

Table 36. Technical Specifications - 5034-IF8C, 5034-IF8CXT

Attribute	5034-IF8C, 5034-IF8CXT
Input range, current	0...20 mA 4...20 mA
Input impedance	Current: 75...115 Ω
Module conversion method	Sigma-delta
Resolution, current ⁽¹⁾ At 50/60 Hz notch filter	16 bits
Calibrated accuracy at 25 °C (77 °F)	Current: 0.1% full scale with 50/60 Hz filter
Calibrated accuracy over full temperature range -25...+60 °C (-13...+140 °F)	Current: 0.2% full scale with 50/60 Hz filter
Fastest scan time per channel	0.4 ms
Fastest scan time per module	1.2 ms
Input notch filter (Hz) selections	10, 20, 50, 60 (Default), 100, 200, 400, 500, 1000, 5000, 10000, 15625, 31250
Input digital filter	First order lag, 0 ms (Default) 0...32,767 ms (32.767 s)

Table 36. Technical Specifications - 5034-IF8C, 5034-IF8CXT (continued)

Attribute	5034-IF8C, 5034-IF8CXT
HART handheld compliance	Not supported
Input overvoltage protection, max	±32V DC
Overcurrent protection	Yes
Data value during overload condition	Full scale, overrange flag, data uncertain/data bad
Open wire detection time	Current: ≤ 1 sec
Onboard data alarming	Yes
Scaling to engineering units	Yes
Real-time channel sampling	Yes
Data format	IEEE 754 32-bit floating point
Rolling timestamp of inputs	Yes

(1) Notch filter dependent.

Table 37. General Specifications - 5034-IF8C, 5034-IF8CXT

Attribute	5034-IF8C, 5034-IF8CXT
Number of inputs	8 channels, single-ended Current mode
SA power voltage, nom	24V DC
SA power voltage range	10...30V DC
SA power current, nom	1.1 A
SA power current, max	1.2 A
SA power current at no load	11 mA
SA reverse polarity protection	Yes
SSV voltage range	Follow SA supply
SSV current, max	1.0 A
SSV short circuit protection	Yes
Power dissipation, max ⁽¹⁾	0.95 W

Table 37. General Specifications - 5034-IF8C, 5034-IF8CXT (continued)

Attribute	5034-IF8C, 5034-IF8CXT
Thermal dissipation, max ⁽¹⁾	3.24 BTU/hr
Isolation voltage	250V (continuous), Basic Insulation Type, System to Field No isolation between SA power and input ports No isolation between individual input ports
Calibration	Factory-calibrated Manual calibration supported, see PointMax Analog I/O Modules User Manual, publication 5034-UM003
RIUP support	Yes
CIP Sync	Yes, slave only ordinary clock
Electronic keying	Electronic keying via programming software
RTB key positions (slot)	2, 5, 8
RTB supported	5034-RTB18, 5034-RTB18S, 5034-RTB24S
Wiring category ⁽²⁾	2 - Signal ports 2 - Power ports
Wiring specification	See Wiring Specifications for Removable Terminal Blocks in the PointMax I/O System Specifications Technical Data, publication 5034-TD001
Indicators	1 green/red module status indicator 1 green/red SA power status indicator 8 yellow/red I/O status indicators
Dimensions (HxWxD), approx	123.6 x 15.0 x 66.4 mm (4.87 x 0.59 x 2.61 in.)
Weight, approx	43.0 g (1.51 oz.) - 5034-IF8C 45.0 g (1.59 oz.) - 5034-IF8CXT
Enclosure type	None (Open-style)
North American temp code	T4
UKEX/ATEX temp code	T4
IECEx temp code	T4

(1) Value is measured at 60 °C (140 °F). Power dissipation varies with temperature.

(2) Use this Conductor Category information for planning conductor routing. See the Industrial Automation Wiring and Grounding Guidelines, publication [1770-4.1](#). Use this Conductor Category information for planning conductor routing as described in the appropriate System Level Installation Manual.

5034-IF8V and 5034-IF8VXT Analog 8 Input Voltage Modules

Figure 34. 5034-IF8V and 5034-IF8VXT Wiring Diagram

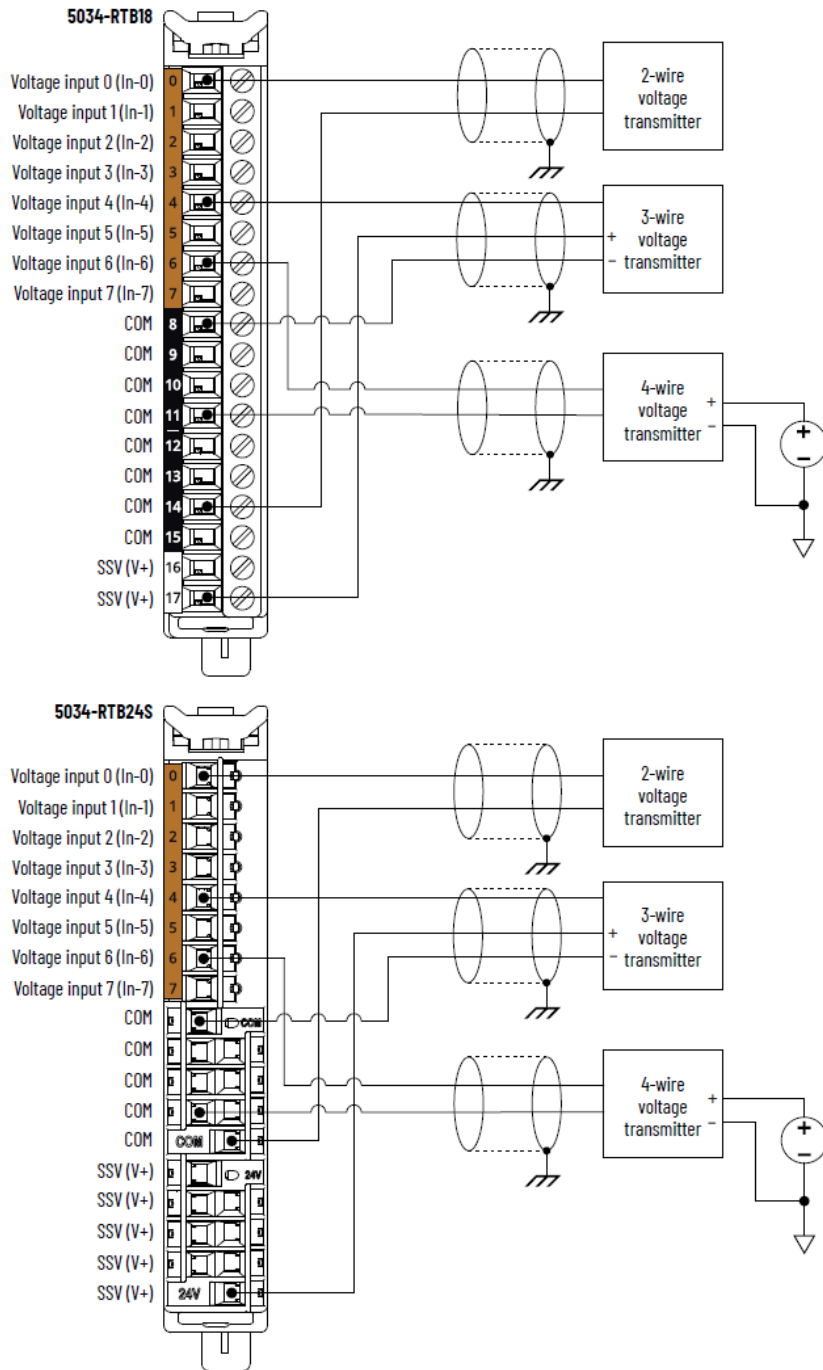

Figure 35. 5034-IF8V and 5034-IF8VXT Functional Block Diagram

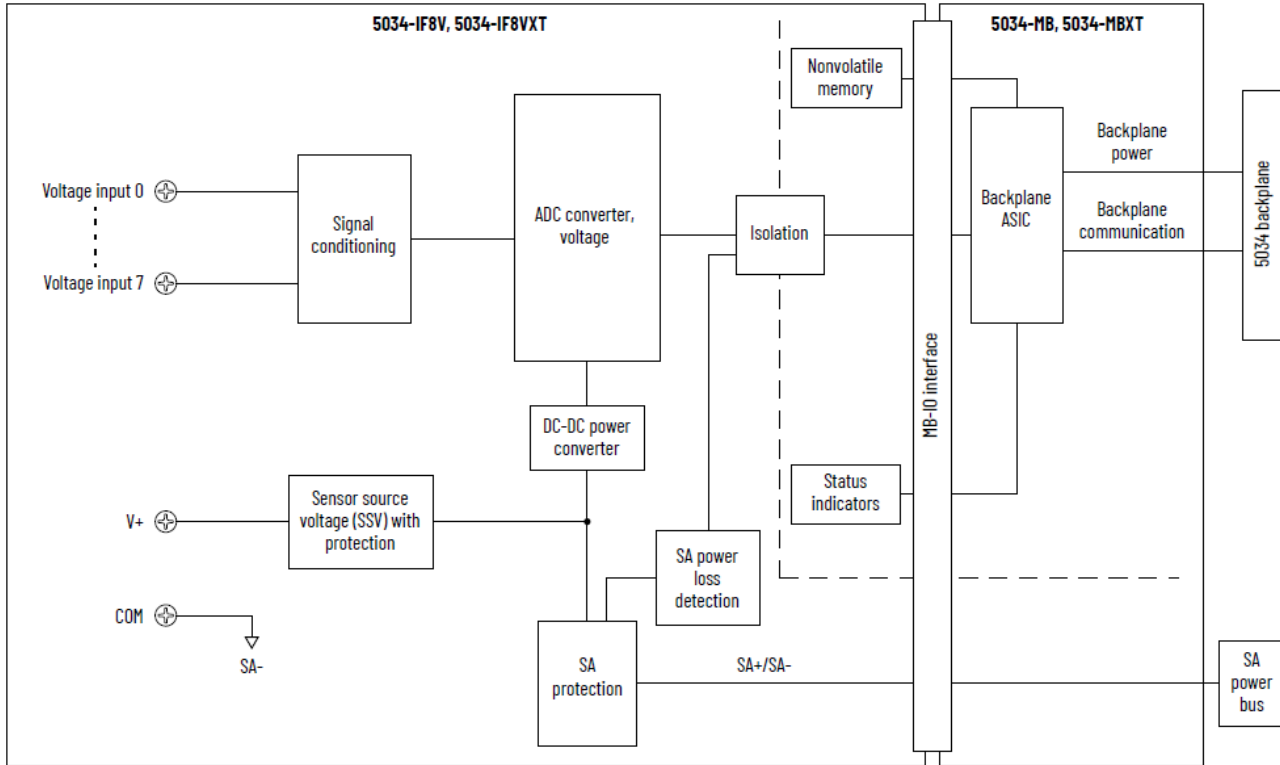

Table 38. Technical Specifications - 5034-IF8V, 5034-IF8VXT

Attribute	5034-IF8V, 5034-IF8VXT
Input range, voltage	±10V 0...10V 0...5V
Input impedance	Voltage: ≥ 1 MΩ
Module conversion method	Sigma-delta
Resolution, voltage ⁽¹⁾ At 50/60 Hz notch filter	16 bits 15 bits for 0...5V range
Calibrated accuracy at 25 °C (77 °F)	Voltage (±10V and 0...10V range): 0.1% full scale with 50/60 Hz filter Voltage (0...5V range): 0.2% full scale with 50/60 Hz filter
Calibrated accuracy over full temperature range -25...+60 °C (-13...+140 °F)	Voltage (±10V and 0...10V range): 0.2% full scale with 50/60 Hz filter Voltage (0...5V range): 0.4% full scale with 50/60 Hz filter
Fastest scan time per channel	0.4 ms
Fastest scan time per module	1.2 ms
Input notch filter (Hz) selections	10, 20, 50, 60 (Default), 100, 200, 400, 500, 1000, 5000, 10000, 15625, 31250

Table 38. Technical Specifications - 5034-IF8V, 5034-IF8VXT (continued)

Attribute	5034-IF8V, 5034-IF8VXT
Input digital filter	First order lag, 0 ms (Default) 0...32,767 ms (32.767 s)
Input overvoltage protection, max	±32V DC
Data value during overload condition	Full scale, overrange flag, data uncertain/data bad
Open wire detection time	Voltage: ≤ 2 sec
Onboard data alarming	Yes
Scaling to engineering units	Yes
Real-time channel sampling	Yes
Data format	IEEE 754 32-bit floating point
Rolling timestamp of inputs	Yes

(1) Notch filter dependent.

Table 39. General Specifications - 5034-IF8V, 5034-IF8VXT

Attribute	5034-IF8V, 5034-IF8VXT
Number of inputs	8 channels, single-ended Voltage mode
SA power voltage, nom	24V DC
SA power voltage range	10...30V DC
SA power current, nom	1.1 A
SA power current, max	1.2 A
SA power current at no load	15 mA
SA reverse polarity protection	Yes
SSV voltage range	Follow SA supply
SSV current, max	1.0 A
SSV short circuit protection	Yes
Power dissipation, max	0.49 W

Table 39. General Specifications - 5034-IF8V, 5034-IF8VXT (continued)

Attribute	5034-IF8V, 5034-IF8VXT
Thermal dissipation, max	1.67 BTU/hr
Isolation voltage	250V (continuous), Basic Insulation Type, System to Field No isolation between SA power and input ports No isolation between individual input ports
Calibration	Factory-calibrated Manual calibration supported, see PointMax Analog I/O Modules User Manual, publication 5034-UM003
RIUP support	Yes
CIP Sync	Yes, slave only ordinary clock
Electronic keying	Electronic keying via programming software
RTB key positions (slot)	2, 6, 8
RTB supported ⁽²⁾	5034-RTB18, 5034-RTB18S, 5034-RTB24S
Wiring category ⁽²⁾	2 - Signal ports 2 - Power ports
Wiring specification	See Wiring Specifications for Removable Terminal Blocks in the PointMax I/O System Specifications Technical Data, publication 5034-TD001
Indicators	1 green/red module status indicator 1 green/red SA power status indicator 8 yellow/red I/O status indicators
Dimensions (HxWxD), approx	123.6 x 15.0 x 66.4 mm (4.87 x 0.59 x 2.61 in.)
Weight, approx	44.0 g (1.55 oz.) - 5034-IF8V 47.0 g (1.66 oz.) - 5034-IF8VXT
Enclosure type	None (Open-style)
North American temp code	T4
UKEX/ATEX temp code	T4
IECEx temp code	T4

(1) Use this Conductor Category information for planning conductor routing. See the Industrial Automation Wiring and Grounding Guidelines, publication [1770-4.1](#). Use this Conductor Category information for planning conductor routing as described in the appropriate System Level Installation Manual.

5034-IF4 and 5034-IF4XT Analog 4 Input Modules

Figure 36. 5034-IF4 and 5034-IF4XT Wiring Diagram - Current Mode

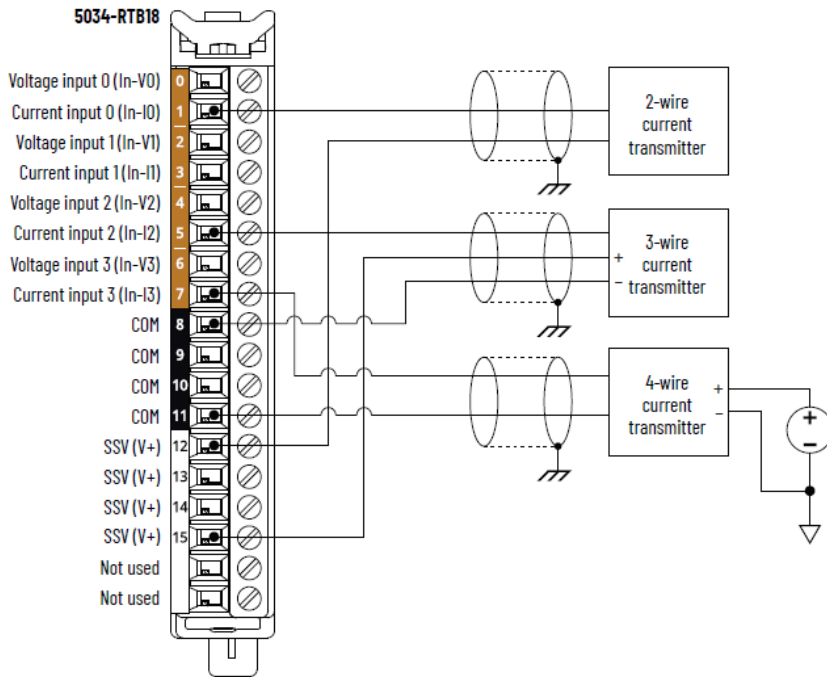

Figure 37. 5034-IF4 and 5034-IF4XT Wiring Diagram - Voltage Mode

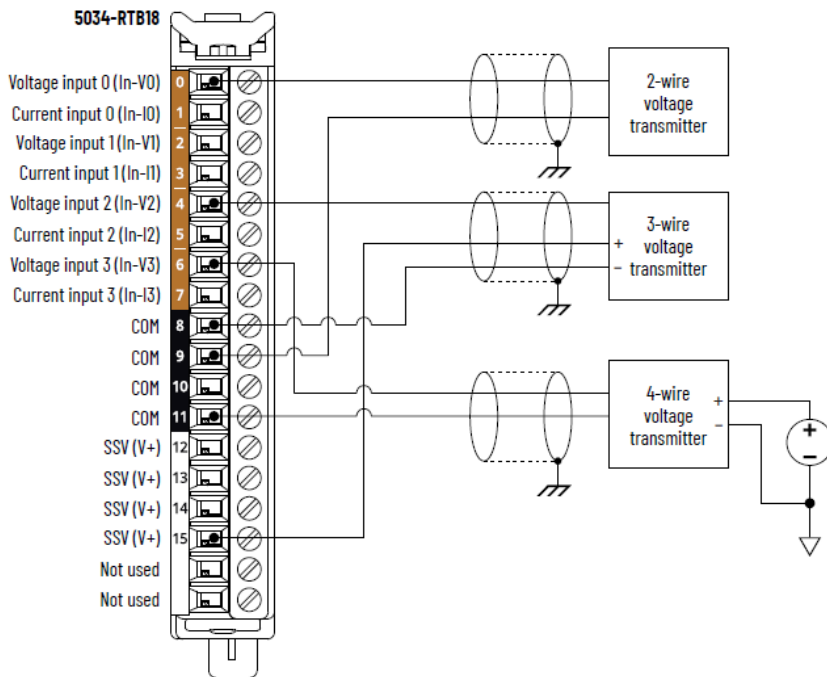

Figure 38. 5034-IF4 and 5034-IF4XT Functional Block Diagram

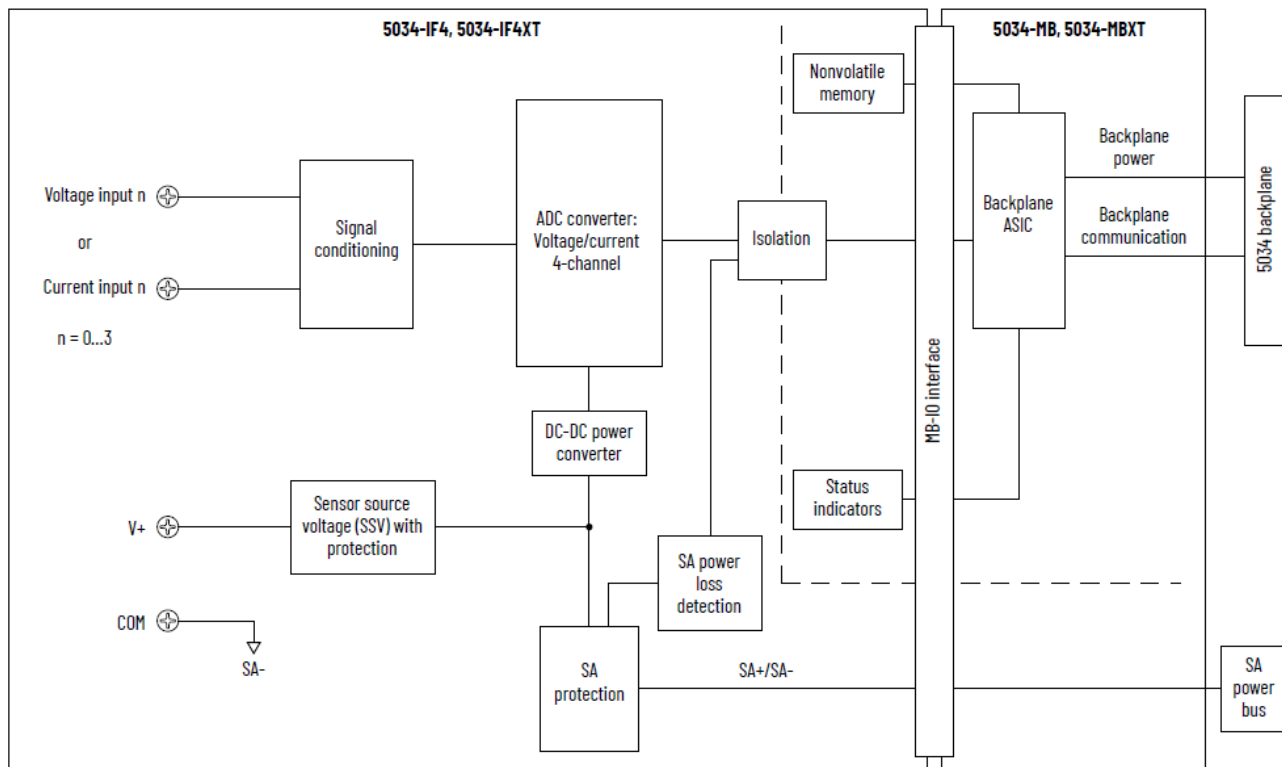

Table 40. Technical Specifications - 5034-IF4, 5034-IF4XT

Attribute	5034-IF4, 5034-IF4XT
Input range, voltage	±10V 0...10V 0...5V
Input range, current	0...20 mA 4...20 mA
Input impedance	Voltage: ≥ 1 MΩ Current: 250 Ω typical
Module conversion method	Sigma-delta
Resolution, voltage ⁽¹⁾ At 50/60 Hz notch filter	16 bits 15 bits for 0...5V range
Resolution, current ⁽¹⁾ At 50/60 Hz notch filter	16 bits
Calibrated accuracy at 25 °C (77 °F)	Voltage (±10V and 0...10V range): 0.1% full scale with 50/60 Hz filter Voltage (0...5V range): 0.2% full scale with 50/60 Hz filter Current: 0.1% full scale with 50/60 Hz filter

Table 40. Technical Specifications - 5034-IF4, 5034-IF4XT (continued)

Attribute	5034-IF4, 5034-IF4XT
Calibrated accuracy over full temperature range -25...+60 °C (-13...+140 °F)	Voltage (±10V and 0...10V range): 0.2% full scale with 50/60 Hz filter Voltage (0...5V range): 0.4% full scale with 50/60 Hz filter Current: 0.2% full scale with 50/60 Hz filter
Fastest scan time per channel	0.4 ms
Fastest scan time per module	1.2 ms
Input notch filter (Hz) selections	10, 20, 50, 60 (Default), 100, 200, 400, 500, 1000, 5000, 10000, 15625, 31250
Input digital filter	First order lag, 0 ms (Default) 0...32,767 ms (32.767 s)
HART handheld compliance	Yes
Input overvoltage protection, max	±32V DC
Overcurrent protection	Yes
Data value during overload condition	Full scale, overrange flag, data uncertain/data bad
Open wire detection time	Voltage: ≤ 2 sec Current: ≤ 1 sec
Onboard data alarming	Yes
Scaling to engineering units	Yes
Real-time channel sampling	Yes
Data format	IEEE 754 32-bit floating point
Rolling timestamp of inputs	Yes

(1) Notch filter dependent

Table 41. General Specifications - 5034-IF4, 5034-IF4XT

Attribute	5034-IF4, 5034-IF4XT
Number of inputs	4 channels, single-ended Configurable voltage or current mode at channel level
SA power voltage, nom	24V DC
SA power voltage range	10...30V DC

Table 41. General Specifications - 5034-IF4, 5034-IF4XT (continued)

Attribute	5034-IF4, 5034-IF4XT
SA power current, nom	1.1 A
SA power current, max	1.2 A
SA power current at no load	11 mA
SA reverse polarity protection	Yes
SSV voltage range	Follow SA supply
SSV current, max	1.0 A
SSV short-circuit protection	Yes
Power dissipation, max ⁽¹⁾	0.91 W
Thermal dissipation, max ⁽¹⁾	3.11 BTU/hr
Isolation voltage	250V (continuous), Basic Insulation Type, System to Field No isolation between SA power and inputs ports No isolation between individual inputs ports
Calibration	Factory-calibrated Manual calibration supported, see PointMax Analog I/O Modules User Manual, publication 5034-UM003
RIUP support	Yes
CIP Sync	Yes, slave only ordinary clock
Electronic keying	Electronic keying via programming software
RTB key positions (slot)	2, 4, 10
RTB supported	5034-RTB18, 5034-RTB18S
Wiring category ⁽²⁾	2 - Signal ports 2 - Power ports
Wiring specification	See Wiring Specifications for Removable Terminal Blocks in the PointMax I/O System Specifications Technical Data, publication 5034-TD001
Indicators	1 green/red module status indicator 1 green/red SA power status indicator 4 yellow/red I/O status indicators
Dimensions (HxWxD), approx	123.6 x 15.0 x 66.4 mm (4.87 x 0.59 x 2.61 in.)
Weight, approx	42.0 g (1.48 oz.) - 5034-IF4

Table 41. General Specifications - 5034-IF4, 5034-IF4XT (continued)

Attribute	5034-IF4, 5034-IF4XT
	45.0 g (1.59 oz.) - 5034-IF4XT
Enclosure type	None (Open-style)
North American temp code	T4
UKEX/ATEX temp code	T4
IECEx temp code	T4

(1) Value is measured at 60 °C (140 °F). Power dissipation varies with temperature.

(2) Use this Conductor Category information for planning conductor routing. See the Industrial Automation Wiring and Grounding Guidelines, publication [1770-4.1](#). Use this Conductor Category information for planning conductor routing as described in the appropriate System Level Installation Manual.

5034-IF4IH and 5034-IF4IHXT Analog 4 Input Isolated HART Modules

Figure 39. 5034-IF4IH and 5034-IF4IHXT Wiring Diagram - Current Mode

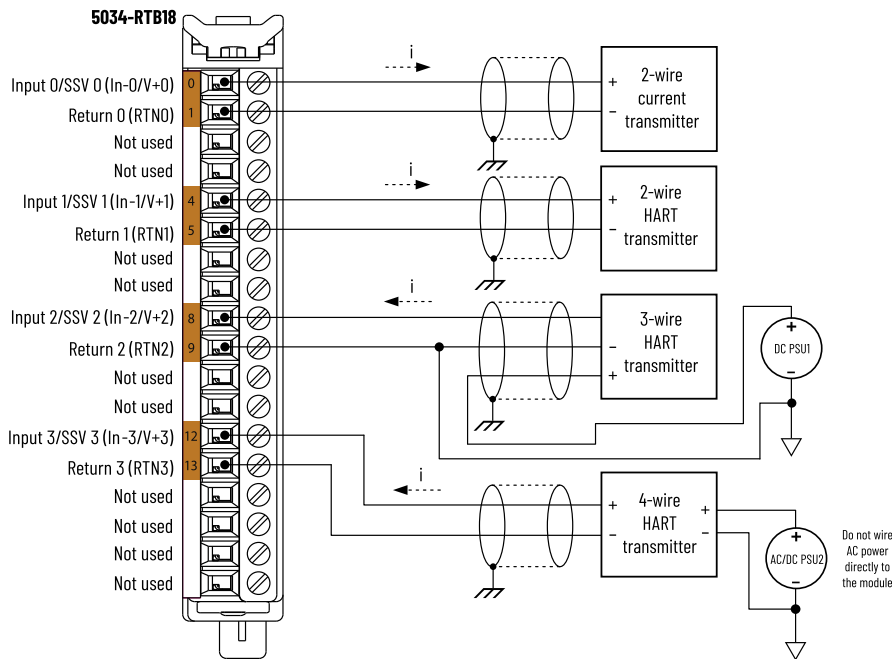

Figure 40. 5034-IF4IH and 5034-IF4IHXT Wiring Diagram - Voltage Mode

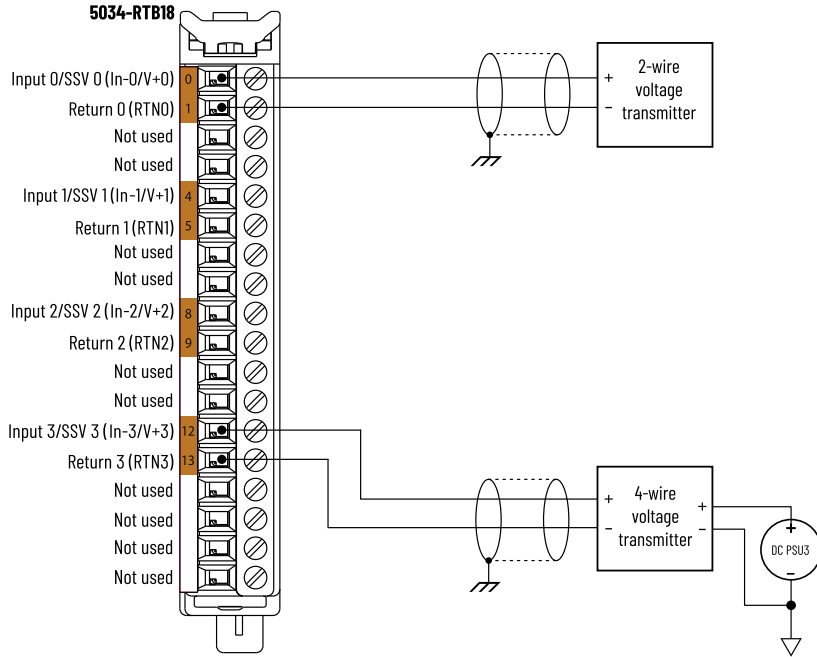

Figure 41. 5034-IF4IH and 5034-IF4IHXT Functional Block Diagram

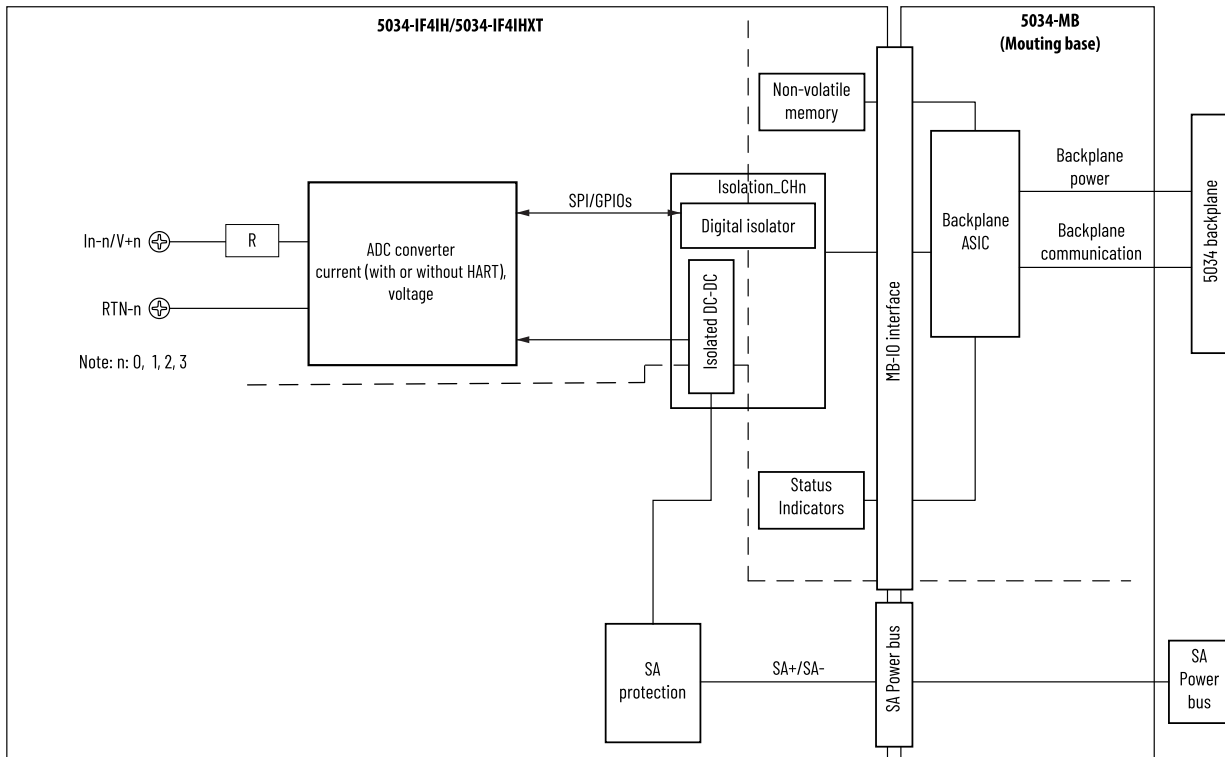

Table 42. Technical Specifications - 5034-IF4IH, 5034-IF4IHXT

Attribute	5034-IF4IH, 5034-IF4IHXT
Input range, voltage	-10...+10V

Table 42. Technical Specifications - 5034-IF4IH, 5034-IF4IHXT (continued)

Attribute	5034-IF4IH, 5034-IF4IHXT
	0...10V 0...5V
Input range, current	0...20 mA 4...20 mA 4...20 mA - HART
Input impedance, voltage	≥ 1 MΩ
Input impedance, current, typical without HART	155 Ω
Input impedance, current, typical with HART	265 Ω
Module conversion method	Sigma-delta 16-bit ADC per channel
HART update rate	Typically 1 s Additional device variables, configured commands, pass through messages, handheld communicators, secondary masters, communication errors, or configuration changes can significantly increase the update time.
Resolution, voltage At 20 Hz notch filter	-10...+10V: 16 bits (366 μV/bit) 0...10V: 15 bits (366 μV/bit) 0...5V: 14 bits (732 μV/bit)
Resolution, current At 20 Hz notch filter	0...20 mA: 15 bits (763 μA/bit) 4...20 mA: 15 bits (763 μA/bit)
Calibrated accuracy at 25 °C (77 °F), HART disabled	Voltage: -10...+10V, ± 0.1% full scale with 20 Hz filter Voltage: 0...10V, ± 0.1% full scale with 20 Hz filter Voltage: 0...5V, ± 0.2% full scale with 20 Hz filter Current: 0...20 mA, ± 0.1% full scale with 20 Hz filter Current: 4...20 mA, ± 0.1% full scale with 20 Hz filter
Calibrated accuracy at 25 °C (77 °F), HART enabled	Current: 4...20 mA, ± 0.1% full scale with 10 Hz filter Current: 4...20 mA, ± 0.1% full scale with 20 Hz filter Current: 4...20 mA, ± 0.3% full scale with 200 Hz filter Current: 4...20 mA, ± 0.6% full scale with 1200 Hz filter
Calibrated accuracy over temperature range -25...+60 °C (-13...+140 °F)	Voltage: -10...+10V, ± 0.2% full scale with 20 Hz filter Voltage: 0...10V, ± 0.2% full scale with 20 Hz filter Voltage: 0...5V, ± 0.4% full scale with 20 Hz filter

Table 42. Technical Specifications - 5034-IF4IH, 5034-IF4IHXT (continued)

Attribute	5034-IF4IH, 5034-IF4IHXT
HART disabled	Current: 0...20 mA, ± 0.2% full scale with 20 Hz filter Current: 4...20 mA, ± 0.2% full scale with 20 Hz filter
Calibrated accuracy over temperature range -25...+60 °C (-13...+140 °F) HART enabled	Current: 4...20 mA, ± 0.2% full scale with 10 Hz filter Current: 4...20 mA, ± 0.2% full scale with 20 Hz filter Current: 4...20 mA, ± 0.35% full scale with 200 Hz filter Current: 4...20 mA, ± 0.65% full scale with 1200 Hz filter
Fastest scan time	1.0 ms with 9600 Hz notch filter
Fastest scan time, per module	1.0 ms
Input notch filter (Hz) selections	HART disabled: 10, 20 with 50/60 Hz noise rejection (Default), 200, 1200, 4800, 9600 HART enabled: 10, 20 with 50/60 Hz noise rejection (Default), 200, 1200
Input digital filter	First order lag, 0 ms (Default) 0...32,767 ms (32.767 s)
Input overvoltage protection, max	±32V DC
Overcurrent protection	Yes, 25 mA typical
Data value during overload condition	Full scale, overrange flag, data uncertain/data fault
Open circuit detection time	Voltage: 4 s typical Current: 0.5 ms typical
Onboard data alarming	Yes
Scaling to engineering units	Yes
Real-time channel sampling	Yes
Data format	IEEE 754 32-bit floating point
Timestamp of inputs	Yes
CIP Sync	Yes

Table 43. General Specifications - 5034-IF4IH, 5034-IF4IHXT

Attribute	5034-IF4IH, 5034-IF4IHXT
Number of inputs	4 channels, individually isolated Supports current sourcing and differential signal

Table 43. General Specifications - 5034-IF4IH, 5034-IF4IHXT (continued)

Attribute	5034-IF4IH, 5034-IF4IHXT
	Configurable voltage or current mode at channel level
SA power voltage, nom	24V DC
SA power voltage range	10...30V DC (Derate to 3 channels for 10...18V DC)
SA power current, nom	125 mA
SA power current, max	300 mA
SA power current at no load	27 mA
Isolated sourcing voltage, min ⁽¹⁾	20 V DC
Sourcing current limit per channel, max	25 mA, typical
SSV overcurrent detection	Yes
Power dissipation, max	1.60 W
Thermal dissipation, max	5.46 BTU/hr
Isolation voltage	250V (continuous), Basic Insulation Type, between system and SA power 250V (continuous), Basic Insulation Type, between SA power and input ports 250V (continuous), Basic Insulation Type, between individual input ports 250V (continuous), Basic Insulation Type, between system and input ports
Calibration	Factory-calibrated Manual calibration supported
RIUP support	Yes
Electronic keying	Electronic keying via programming software
RTB key position (slot)	2, 6, 10
RTB supported	5034-RTB18, 5034-RTB18S
Wiring category ⁽²⁾	2 - Signal ports 2 - Power ports
Wiring specification	See Wiring Specifications for Removable Terminal Blocks in the PointMax I/O System Specifications Technical Data, publication 5034-TD001
Indicators	1 green/red module status indicator 1 green/red SA power status indicator 4 yellow/red I/O status indicators

Table 43. General Specifications - 5034-IF4IH, 5034-IF4IHXT (continued)

Attribute	5034-IF4IH, 5034-IF4IHXT
Dimensions (HxWxD), approx	123.6 x 15.0 x 66.4 mm (4.87 x 0.59 x 2.61 in.)
Weight, approx	51.0 g (1.80 oz.) - 5034-IF4IH 53.0 g (1.87 oz.) - 5034-IF4IHXT
Enclosure type	None (Open-style)
North American temp code	T4
UKEX/ATEX temp code	T4
IECEx temp code	T4

(1) 20V DC is connected to screw via series impedance. Series impedance is as per value published. Measured voltage is Sourcing Voltage minus Voltage drop across series impedance based on the current drawn.

(2) Use this Conductor Category information for planning conductor routing. See the Industrial Automation Wiring and Grounding Guidelines, publication [1770-4.1](#). Use this Conductor Category information for planning conductor routing as described in the appropriate System Level Installation Manual.

5034-IRT4I and 5034-IRT4IXT Analog 4 Input Isolated RTD/TC Modules

Figure 42. 5034-IRT4I and 5034-IRT4IXT Wiring Diagram – RTD Mode

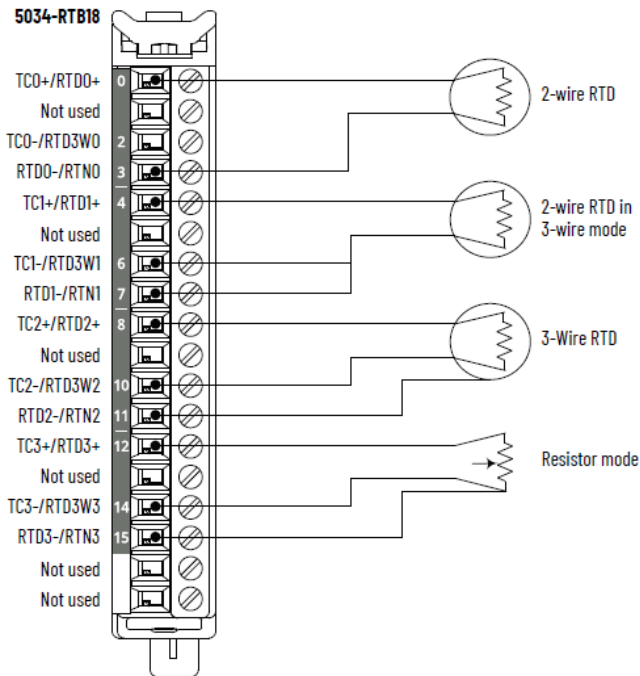

Figure 43. 5034-IRT4I and 5034-IRT4IXT Wiring Diagram – Thermocouple Mode

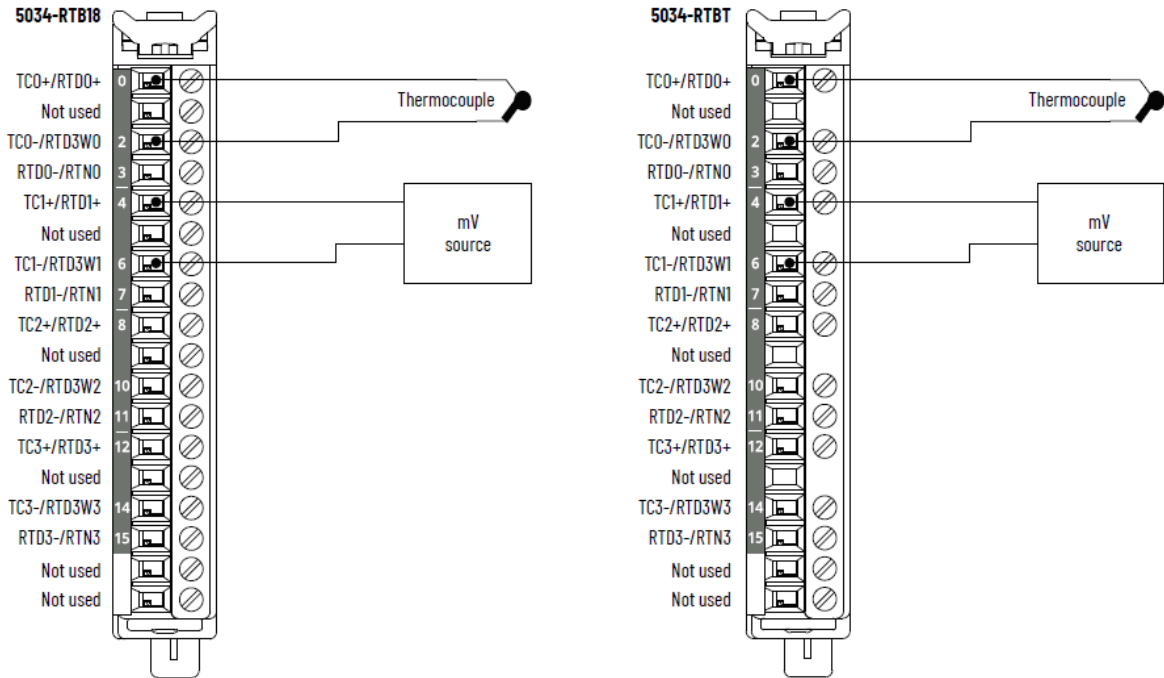

Figure 44. 5034-IRT4I and 5034-IRT4IXT Functional Block Diagram

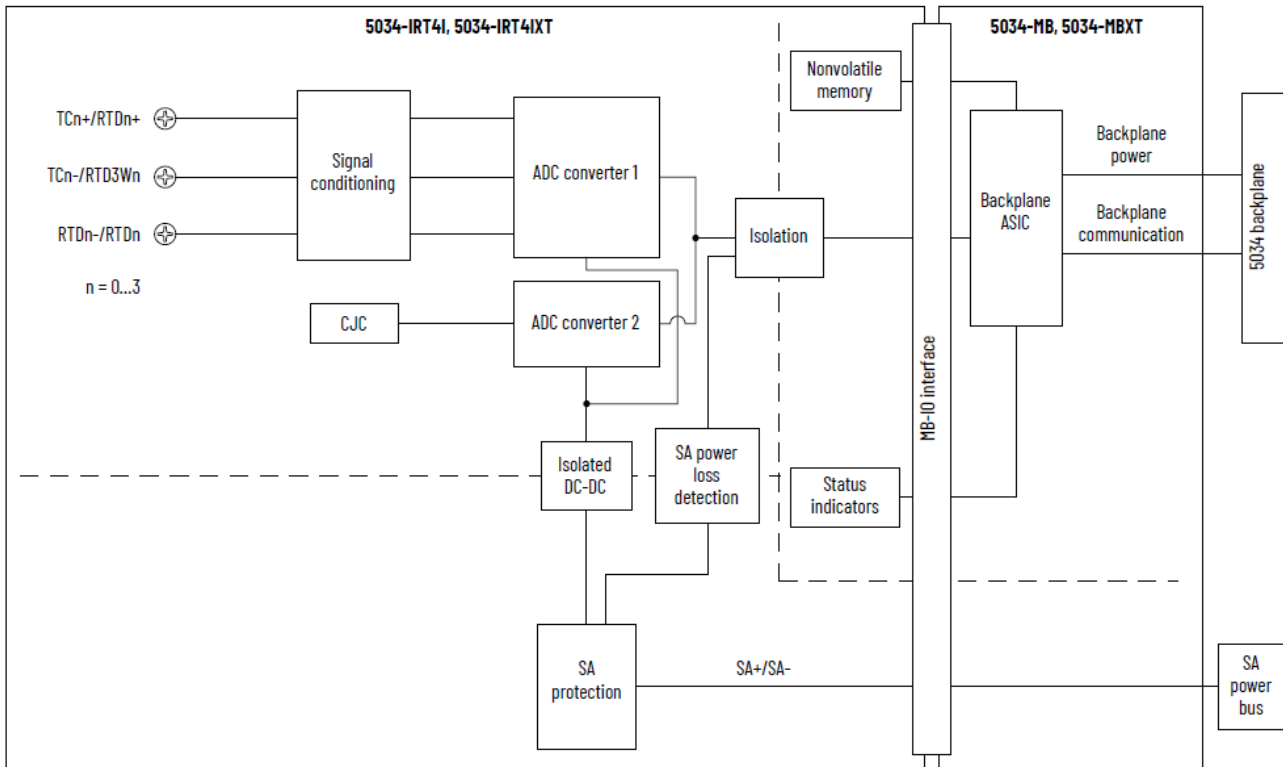

Table 44. Technical Specifications - 5034-IRT4I, 5034-IRT4IXT

Attribute	5034-IRT4I, 5034-IRT4IXT
Input range, resistive	1...500 Ω

Table 44. Technical Specifications - 5034-IRT4I, 5034-IRT4IXT (continued)

Attribute	5034-IRT4I, 5034-IRT4IXT
	2...1000 Ω 4...2000 Ω 8...4000 Ω
Input type, RTD	100, 200, 500, 1000 Ω platinum, alpha = 385 100, 200, 500, 1000 Ω platinum, alpha = 3916 120 Ω nickel, alpha = 672 100, 120, 200, 500 Ω nickel, alpha = 618 10 Ω copper 427
Input range, thermocouple/millivolt	± 100 mV
Input type, thermocouple	B, C, D, E, J, K, N, R, S, T, TXK/XX(L)
Input impedance	Thermocouple/millivolt: > 1 M Ω RTD: > 1 M Ω
Common mode voltage (channel to channel)	250V (continuous), Basic Isolation
Module conversion method	Sigma-delta, 24-bit multiplexed ADC
Resolution, RTD/resistive At 50/60 Hz notch filter	16 bit
Resolution, thermocouple/millivolt At 50/60 Hz notch filter	16 bit
RTD excitation current	250 μ A for 1000, 2000, 4000 Ω range 500 μ A for 500 Ω range
Thermocouple linearization	ITS-90
CJ mode	Onboard CJC, RTB CJC, remote CJC
Onboard CJC inputs (for thermocouple mode use only)	CJC sensors Four thermistors embedded in 5034-IRT4I and 5034-IRT4IXT Vishay NTC5005E3103FHT
Onboard CJC sensor accuracy	± 3.0 $^{\circ}$ C, 0 $^{\circ}$ C < T_{amb} < 60 $^{\circ}$ C (± 5.4 $^{\circ}$ F, 32 $^{\circ}$ F < T_{amb} < 140 $^{\circ}$ F) ± 4.0 $^{\circ}$ C, -25 $^{\circ}$ C < T_{amb} < 0 $^{\circ}$ C (± 7.2 $^{\circ}$ F, -13 $^{\circ}$ F < T_{amb} < 32 $^{\circ}$ F)
RTB CJC inputs (for thermocouple mode use only)	CJC sensors Four thermistors embedded in 5034-RTBT and 5034-RTBTS TE Connectivity TE 10K3A1A

Table 44. Technical Specifications - 5034-IRT4I, 5034-IRT4IXT (continued)

Attribute	5034-IRT4I, 5034-IRT4IXT
RTB CJC sensor accuracy	$\pm 0.6\text{ }^{\circ}\text{C}$, $0\text{ }^{\circ}\text{C} < T_{\text{amb}} < 60\text{ }^{\circ}\text{C}$ ($\pm 1.1\text{ }^{\circ}\text{F}$, $32\text{ }^{\circ}\text{F} < T_{\text{amb}} < 140\text{ }^{\circ}\text{F}$) $\pm 1.2\text{ }^{\circ}\text{C}$, $-25\text{ }^{\circ}\text{C} < T_{\text{amb}} < 0\text{ }^{\circ}\text{C}$ ($\pm 2.2\text{ }^{\circ}\text{F}$, $-13\text{ }^{\circ}\text{F} < T_{\text{amb}} < 32\text{ }^{\circ}\text{F}$)
CJC conversion method	12-bit SAR
Calibrated accuracy at 25 °C (77 °F)	Thermocouple/millivolt: 0.1% full scale with 50/60 Hz filter RTD: 500 Ω , 1 k Ω , 2 k Ω , 4 k Ω range, 0.1% full scale with 50/60 Hz filter
Calibrated accuracy over full temperature range -25...+60 °C (-13...+140 °F)	Thermocouple/millivolt: 0.25% full scale with 50/60 Hz filter RTD: 500 Ω , 1 k Ω , 2 k Ω , 4 k Ω range, 0.25% full scale with 50/60 Hz filter
Fastest scan time per channel	0.36 ms
Fastest scan time per module	0.36 ms
Input notch filter selections (Hz)	10, 20, 50, 60 (Default), 100, 200, 500, 1000, 2500, 5000
Hardware input filter	1 kHz
Input digital filter	First order lag, 0 ms (Default) 0...32,767 ms (32.767 s)
Normal mode noise rejection ratio	65 dB @ 50/60 Hz, notch filter dependent
Open wire detection time	< 200 ms
Overvoltage protection, max	32V DC
Scaling to engineering units	Yes
Real-time channel sampling	Yes
Rolling timestamp of inputs	Yes
Data format	IEEE 754 32-bit floating point

Table 45. Technical Specifications - 5034-IRT4I, 5034-IRT4IXT - RTD Sensors

RTD Sensor Types ⁽¹⁾	Temperature Range
100, 200, 500, 1000 Ω PT 385	-200...+870 °C -328...+1598 °F 73...1143 K 132...2058 °R
100, 200, 500, 1000 Ω PT 3916	-200...+630 °C

Table 45. Technical Specifications - 5034-IRT4I, 5034-IRT4IXT - RTD Sensors (continued)

RTD Sensor Types ⁽¹⁾	Temperature Range
	-328...+1166 °F 73...903 K 132...1626 °R
10 Ω CU 427	-200...+260 °C -328...+500 °F 73...533 K 132...960 °R
120 Ω NI 672	-80...+320 °C -112...+608 °F 193...593 K 348...1068 °R
100, 120, 200, 500 Ω NI 618	-60...+250 °C -76...+482 °F 213...523 K 384...942 °R

(1) Each sensor type supports all temperature ranges listed.

Table 46. Technical Specifications - 5034-IRT4I, 5034-IRT4IXT - Thermocouples

Thermocouple Type	Temperature Range
Thermocouple type B	21...1820 °C 68...3308 °F 293...2093 K 528...3768 °R
Thermocouple type C	0...2315 °C 32...4199 °F 273...2588 K 492...4659 °R
Thermocouple type D	0...2315 °C 32...4199 °F 273...2588 K 492...4659 °R
Thermocouple type E	-270...+1000 °C -454...+1832 °F

Table 46. Technical Specifications - 5034-IRT4I, 5034-IRT4IXT - Thermocouples (continued)

Thermocouple Type	Temperature Range
	3...1273 K 6...2292 °R
Thermocouple type J	-210...+1200 °C -346...+2192 °F 63...1473 K 114...2652 °R
Thermocouple type K	-270...+1372 °C -454...+2502 °F 3...1645 K 6...2961 °R
Thermocouple type N	-270...+1300 °C -454...+2372 °F 3...1573 K 6...2832 °R
Thermocouple type R	-50...+1768 °C -58...+3215 °F 223...2041 K 402...3674 °R
Thermocouple type S	-50...+1768 °C -58...+3215 °F 223...2041 K 402...3674 °R
Thermocouple type T	-270...+400 °C -454...+752 °F 3...673 K 6...1212 °R
Thermocouple type TXK/XK(L)	-200...+800 °C -328...+1472 °F 73...1073 K 132...1932 °R

Table 47. General Specifications - 5034-IRT4I, 5034-IRT4IXT

Attribute	5034-IRT4I, 5034-IRT4IXT
Number of inputs	4 channels (4 isolated group)
SA power voltage, nom	24V DC
SA power voltage range	10...30V DC
SA power current, nom	50 mA
SA power current, max	0.1 A
SA power current at no load	11 mA
SA reverse polarity protection	Yes
Power dissipation, max ⁽¹⁾	0.42 W
Thermal dissipation, max ⁽¹⁾	1.43 BTU/hr
Isolation voltage	250V (continuous), Basic Insulation Type, System to Field 250V (continuous), Basic Insulation Type, SA power and input ports 250V (continuous), Basic Insulation Type, between individual input ports
Calibration	Factory-calibrated Manual calibration supported, see PointMax Analog I/O Modules User Manual, publication 5034-UM003
RIUP support	Yes
CIP Sync	Yes, slave only ordinary clock
Electronic keying	Electronic keying via programming software
RTB key positions (slot)	2, 7, 10
RTB supported	5034-RTB18, 5034-RTB18S, 5034-RTBT, 5034-RTBTS To help achieve better accuracy, use the CJC thermistors that are embedded in 5034-RTBT and 5034-RTBTS.
Wiring category ⁽²⁾	2 - Signal ports 2 - Power ports
Wiring specification	See Wiring Specifications for Removable Terminal Blocks in the PointMax I/O System Specifications Technical Data, publication 5034-TD001
Indicators	1 green/red module status indicator 1 green/red SA power status indicator 4 yellow/red I/O status indicators
Dimensions (HxWxD), approx	123.6 x 15.0 x 66.4 mm (4.87 x 0.59 x 2.61 in.)
Weight, approx	45.0 g (1.59 oz.) - 5034-IRT4I

Table 47. General Specifications - 5034-IRT4I, 5034-IRT4IXT (continued)

Attribute	5034-IRT4I, 5034-IRT4IXT
	48.0 g (1.69 oz.) - 5034-IRT4IXT
Enclosure type	None (Open-style)
North American temp code	T4
UKEX/ATEX temp code	T4
IECEx temp code	T4

(1) Value is measured at 60 °C (140 °F). Power dissipation varies with temperature.

(2) Use this Conductor Category information for planning conductor routing. See the Industrial Automation Wiring and Grounding Guidelines, publication [1770-4.1](#). Use this Conductor Category information for planning conductor routing as described in the appropriate System Level Installation Manual.

5034-OF4 and 5034-OF4XT Analog 4 Output Modules

Figure 45. 5034-OF4 and 5034-OF4XT Wiring Diagram - Current Mode

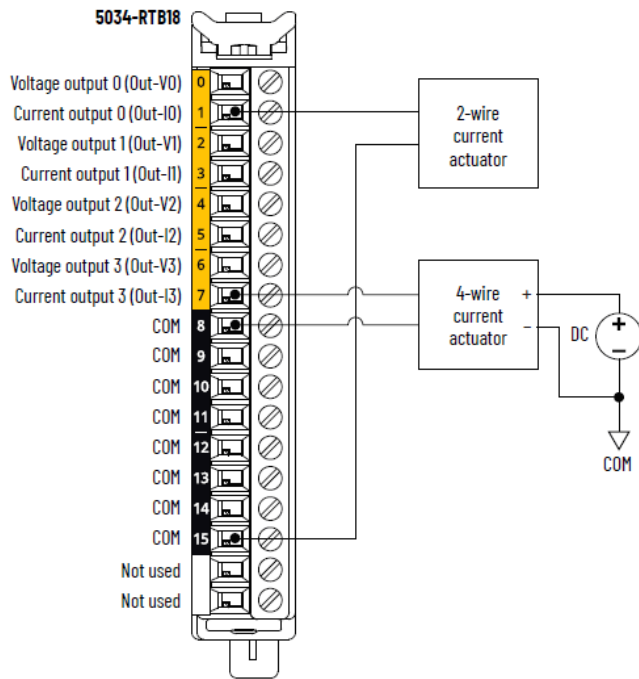

Figure 46. 5034-OF4 and 5034-OF4XT Wiring Diagram - Voltage Mode

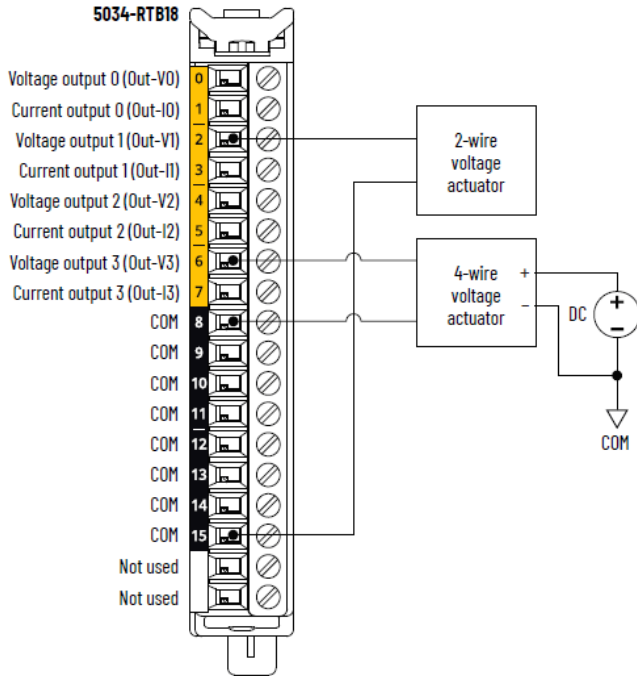

Figure 47. 5034-OF4 and 5034-OF4XT Functional Block Diagram

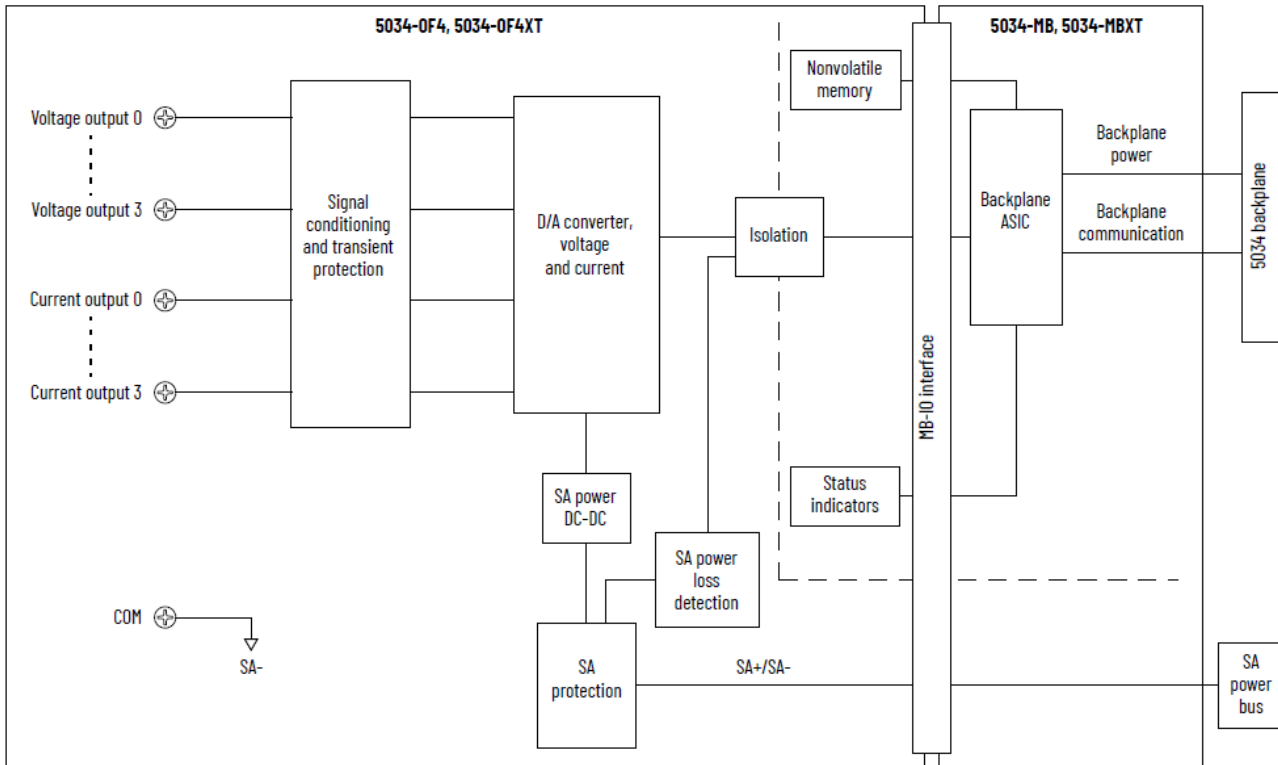

Table 48. Technical Specifications - 5034-OF4, 5034-OF4XT

Attribute	5034-OF4, 5034-OF4XT
Output range, voltage	±10V

Table 48. Technical Specifications - 5034-0F4, 5034-0F4XT (continued)

Attribute	5034-0F4, 5034-0F4XT
	0...10V 0...5V
Output range, current	0...20 mA 4...20 mA
Resolution, voltage	±10V: 15 bits 0...10V: 16 bits 0...5V: 16 bits
Resolution, current	16 bits
Calibrated accuracy at 25 °C (77 °F)	Voltage: 0.10% full scale Current: 0.10% full scale
Calibrated accuracy over full temperature range -25...+60 °C (-13...+140 °F)	Voltage: 0.2% full scale Current: 0.2% full scale
Drive capability	Voltage: 3000 Ω min Current: 500 Ω max
Capacitive load, max (voltage mode only)	1 μF
Inductive load, max (current mode only)	1 mH
HART handheld compliance	Yes
Open wire detection	Current mode only
Short circuit detection	Voltage mode only – Output electronically limited to 16 mA or less
Data format	IEEE 754 32-bit floating point
Module conversion method	DAC
Update rate	1 channel: 0.2 ms All channels: 0.4 ms
Step response time to 63% of full scale per channel	Voltage mode: 0.07 ms typical Current mode: 0.4 ms typical
Backplane to screw response time (63% of full scale)	Voltage mode 1 channel: 0.5 ms typical All channels: 1 ms typical Current mode:

Table 48. Technical Specifications - 5034-OF4, 5034-OF4XT (continued)

Attribute	5034-OF4, 5034-OF4XT
	1 channel: 0.9 ms typical All channels: 1.4 ms typical
Overvoltage protection, max	32V DC

Table 49. General Specifications - 5034-OF4, 5034-OF4XT

Attribute	5034-OF4, 5034-OF4XT
Number of outputs	4 channels, single-ended Configurable voltage or current mode at channel level
SA power voltage, nom	24V DC
SA power voltage range	10...30V DC
SA power current, nom	100 mA
SA power current, max	0.25 A
SA power current at no load	40 mA
SA reverse polarity protection	Yes
Power dissipation, max	0.95 W
Thermal dissipation, max	3.24 BTU/hr
Isolation voltage	250V (continuous), Basic Insulation Type, System to Field No isolation between SA power and output ports No isolation between individual output ports
Calibration	Factory-calibrated Manual calibration supported, see PointMax Analog I/O Modules User Manual, publication 5034-UM003
RIUP support	Yes
Electronic keying	Electronic keying via programming software
RTB key positions (slot)	2, 5, 10
RTB supported	5034-RTB18, 5034-RTB18S
Wiring category ⁽¹⁾	2 - Signal ports 2 - Power ports
Wiring specification	See Wiring Specifications for Removable Terminal Blocks in the PointMax I/O System Specifications Technical Data, publication 5034-TD001

Table 49. General Specifications - 5034-0F4, 5034-0F4XT (continued)

Attribute	5034-0F4, 5034-0F4XT
Indicators	1 green/red module status indicator 1 green/red SA power status indicator 4 yellow/red I/O status indicators
Dimensions (HxWxD), approx	123.6 x 15.0 x 66.4 mm (4.87 x 0.59 x 2.61 in.)
Weight, approx	47.0 g (1.66 oz.) - 5034-0F4 49.0 g (1.73 oz.) - 5034-0F4XT
Enclosure type	None (Open-style)
North American temp code	T4
UKEX/ATEX temp code	T4
IECEx temp code	T4

(1) Use this Conductor Category information for planning conductor routing. See the Industrial Automation Wiring and Grounding Guidelines, publication [1770-4.1](#). Use this Conductor Category information for planning conductor routing as described in the appropriate System Level Installation Manual.

5034-0F4IH and 5034-0F4IHXT Analog 4 Output Isolated HART Modules

Figure 48. 5034-0F4IH and 5034-0F4IHXT Wiring Diagram - Current Mode

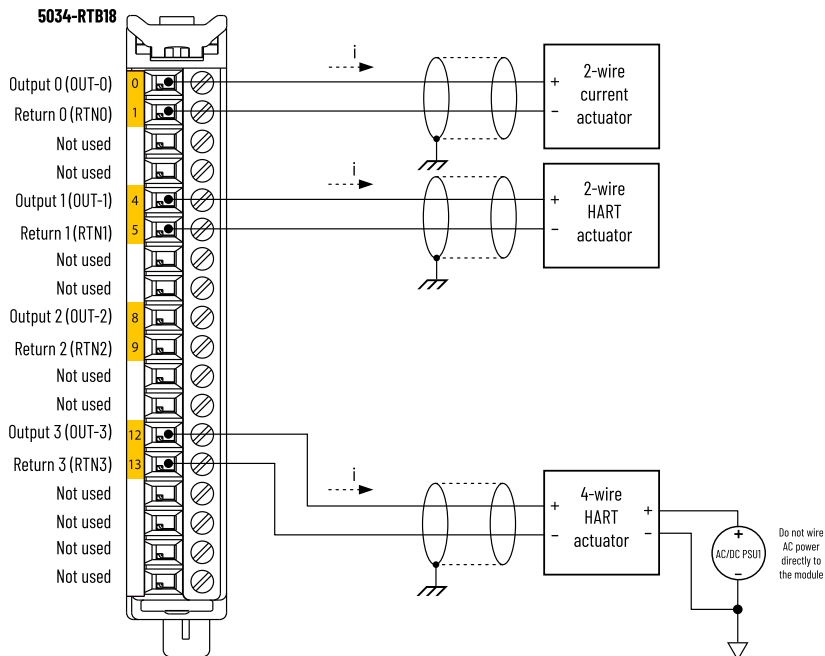

Figure 49. 5034-0F4IH and 5034-0F4IHXT Wiring Diagram - Voltage Mode

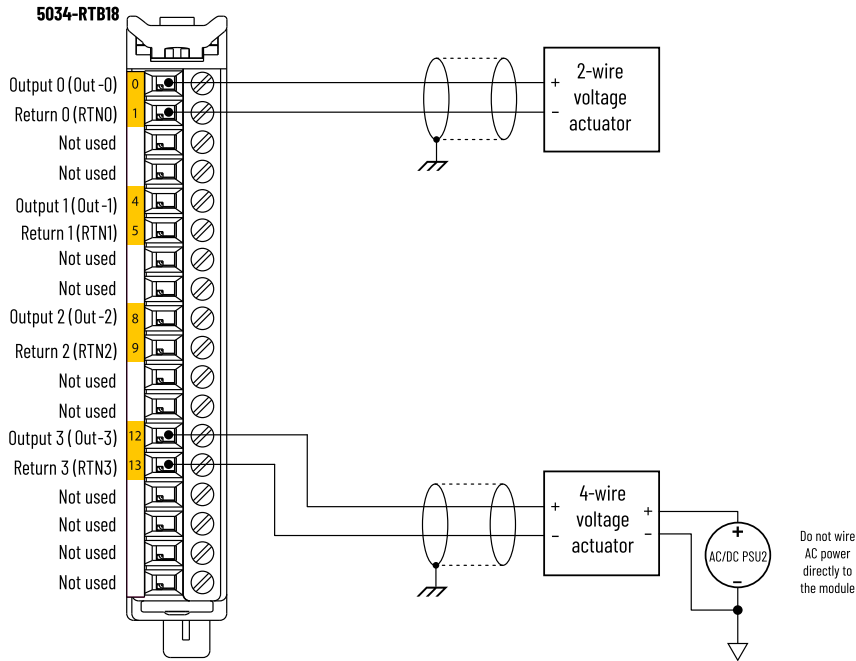

Figure 50. 5034-0F4IH and 5034-0F4IHXT Functional Block Diagram

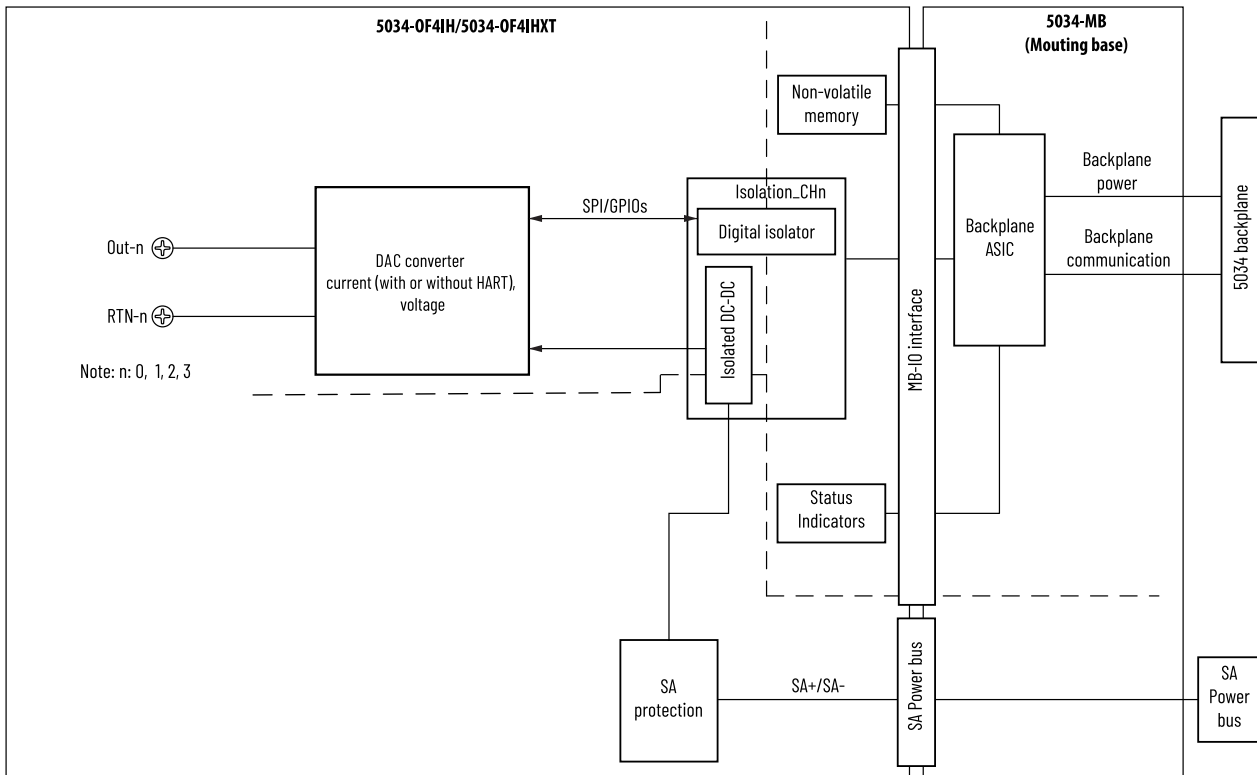

Table 50. Technical Specifications - 5034-0F4IH, 5034-0F4IHXT

Attribute	5034-0F4IH, 5034-0F4IHXT
Output range, voltage	-10...+10V

Table 50. Technical Specifications - 5034-OF4IH, 5034-OF4IHXT (continued)

Attribute	5034-OF4IH, 5034-OF4IHXT
	0...10V 0...5V
Output range, current	0...20 mA 4...20 mA 4...20 mA - HART
Resolution, voltage	-10...+10V: 14 bits (1.465 mV/bit) 0...10V: 14 bits (732 μ V/bit) 0...5V: 13 bits (732 μ V/bit)
Resolution, current	0...20 mA range: 14 bits (1.526 μ A/bit) 4...20 mA range: 14 bits (1.526 μ A/bit)
Calibrated accuracy at 25 °C (77 °F) HART disabled	Voltage +10...+10V, 0.1% full scale Voltage 0...10V, \pm 0.1% full scale Voltage: 0...5V, \pm 0.2% full scale Current: 0...20 mA, \pm 0.1% full scale Current: 4...20 mA, \pm 0.1% full scale
Calibrated accuracy over full temperature range -25...+60 °C (-13...+140 °F) HART disabled	Voltage: -10...+10V, \pm 0.2% full scale Voltage: 0...10V, \pm 0.2% full scale Voltage: 0...5V, \pm 0.4% full scale Current: 0...20 mA, \pm 0.2% full scale Current: 4...20 mA, \pm 0.2% full scale
Drive capability	Voltage: 3000 Ω Current: 750 Ω
Capacitive load, max Voltage mode	1 μ F
Inductive load, max Current mode	1 mH
Open wire detection	Current mode only
Short circuit detection	Voltage mode only
Data format	IEEE 754 32-bit floating point
Module conversion method	DAC

Table 50. Technical Specifications - 5034-0F4IH, 5034-0F4IHXT (continued)

Attribute	5034-0F4IH, 5034-0F4IHXT
HART update rate	Typically 1 s Additional device variables, configured commands, pass through messages, handheld communicators, secondary masters, communication errors, or configuration changes can significantly increase the update time.
Update rate Voltage and current mode	1 ms
Step response time to 63% of value, typical HART disabled	Voltage mode: 90 μ s typical Current mode: 50 μ s typical
Backplane to screw response time (63% of full scale) HART disabled	Voltage mode: <ul style="list-style-type: none"> • 1 channel: 0.4 ms typical • All channel: 0.4 ms typical Current mode: <ul style="list-style-type: none"> • 1 channel: 0.4 ms typical • All channel: 0.6 ms typical
Overvoltage protection, max	32V DC

Table 51. General Specifications - 5034-0F4IH, 5034-0F4IHXT

Attribute	5034-0F4IH, 5034-0F4IHXT
Number of outputs	4 channels, individually isolated Configurable voltage or current mode at channel level
SA power voltage, nom	24V DC
SA power voltage range	10...30V DC
SA power current, nom	110 mA
SA power current, max	275 mA
SA power current at no load	27 mA
SA reverse polarity protection	Yes
Power dissipation, max	1.55 W
Thermal dissipation, max	5.29 BTU/hr
Isolation voltage	250V (continuous), Basic Insulation Type, between system and SA power 250V (continuous), Basic Insulation Type, between SA power and input ports 250V (continuous), Basic Insulation Type, between individual input ports 250V (continuous), Basic Insulation Type, between system and input ports

Table 51. General Specifications - 5034-0F4IH, 5034-0F4IHXT (continued)

Attribute	5034-0F4IH, 5034-0F4IHXT
Calibration	Factory-calibrated Manual calibration supported
RIUP support	Yes
Electronic keying	Electronic keying via programming software
RTB key positions (slot)	2, 6, 10
RTB supported	5034-RTB18, 5034-RTB18S
Wiring category ⁽¹⁾	2 - Signal ports 2 - Power ports
Wiring specification	See Wiring Specifications for Removable Terminal Blocks in the PointMax I/O System Specifications Technical Data, publication 5034-TD001
Indicators	1 green/red module status indicator 1 green/red SA power status indicator 4 yellow/red I/O status indicators
Dimensions (HxWxD), approx	123.6 x 15.0 x 66.4 mm (4.87 x 0.59 x 2.61 in.)
Weight, approx	51.0 g (1.80 oz.) - 5034-0F4IH 55.0 g (1.94 oz.) - 5034-0F4IHXT
Enclosure type	None (Open-style)
North American temp code	T4
UKEX/ATEX temp code	T4
IECEx temp code	T4

(1) Use this Conductor Category information for planning conductor routing. See the Industrial Automation Wiring and Grounding Guidelines, publication [1770-4.1](#). Use this Conductor Category information for planning conductor routing as described in the appropriate System Level Installation Manual.

Environmental Specifications and Certifications

The following tables provide the environmental specifications and certifications for the PointMax analog I/O modules.

Table 52. Environmental Specifications - PointMax Analog I/O Modules

Attribute	5034-IF8C, 5034-IF8V, 5034-IF4, 5034-IF4IH, 5034-IRT4I, 5034-0F4, 5034-0F4IH	5034-IF8CXT, 5034-IF8VXT, 5034-IF4XT, 5034-IF4IHXT, 5034-IRT4IXT, 5034-0F4XT, 5034-0F4IHXT
Temperature, operating	IEC 60068-2-1 (Test Ae, Operating Cold), IEC 60068-2-2 (Test Be, Operating Dry Heat),	

Table 52. Environmental Specifications - PointMax Analog I/O Modules (continued)

Attribute	5034-IF8C, 5034-IF8V, 5034-IF4, 5034-IF4IH, 5034-IRT4I, 5034-OF4, 5034-OF4IH	5034-IF8CXT, 5034-IF8VXT, 5034-IF4XT, 5034-IF4IHXT, 5034-IRT4IXT, 5034-OF4XT, 5034-OF4IHXT
	IEC 60068-2-14 (Test Nb, Operating Thermal Shock): -25 °C ≤ Ta ≤ +60 °C (-13 °F ≤ Ta ≤ +140 °F) for horizontal orientation -25 °C ≤ Ta ≤ +55 °C (-13 °F ≤ Ta ≤ +131 °F) for other orientations	
Temperature, surrounding air, max	60 °C (140 °F)	
Temperature, nonoperating	IEC 60068-2-1 (Test Ab, Unpackaged Nonoperating Cold), IEC 60068-2-2 (Test Bb, Unpackaged Nonoperating Dry Heat), IEC 60068-2-14 (Test Na, Unpackaged Nonoperating Thermal Shock): -40...+85 °C (-40...+185 °F)	
Relative humidity	IEC 60068-2-30 (Test Db, Unpackaged Damp Heat): 5...95% noncondensing	
Conformal coated	No	Yes
Corrosive Atmosphere ASTM B845-97 Method K Accelerated Test (20-Day Exposure)	Severity Level G3 ⁽¹⁾ per ANSI/ISA 71.04-2013, Airborne Contaminants—Gases	
Corrosive Atmosphere <ul style="list-style-type: none"> • ASTM B845-97 Method K Accelerated Test (30-Day Exposure) • Plus additional Rockwell Automation proprietary accelerated corrosive environment test protocol for specific industries with sources of gaseous sulfur compounds. 	—	Severity Level GX ⁽²⁾ per ANSI/ISA 71.04-2013, Airborne Contaminants—Gases Severity Level CX per IEC 60721-3-3:2019, Chemically Active Substances
Vibration	IEC 60068-2-6 (Test Fc, Operating): 5 g @ 10...500 Hz	
Shock, operating	IEC 60068-2-27 (Test Ea, Unpackaged Shock): 30 g	
Repetitive shock, operating	IEC 60068-2-27: 25 g, 6 ms duration, 1000 shocks in each ± direction in each 3 axis	
Shock, nonoperating	IEC 60068-2-27 (Test Ea, Unpackaged Shock):	

Table 52. Environmental Specifications - PointMax Analog I/O Modules (continued)

Attribute	5034-IF8C, 5034-IF8V, 5034-IF4, 5034-IF4IH, 5034-IRT4I, 5034-OF4, 5034-OF4IH	5034-IF8CXT, 5034-IF8VXT, 5034-IF4XT, 5034-IF4IHXT, 5034-IRT4IXT, 5034-OF4XT, 5034-OF4IHXT
	50 g	
Emissions	IEC 61000-6-4	
ESD immunity	IEC 61000-4-2: 6 kV contact discharges 8 kV air discharges	
Radiated RF immunity	IEC 61000-4-3: 10V/m with 1 kHz sine wave 80% AM from 80...6000 MHz	
EFT/B immunity	IEC 61000-4-4: ±3 kV @ 5 kHz on signal ports	
Surge transient immunity	IEC 61000-4-5: ±1 kV line-line (DM) and ±2 kV line-earth (CM) on signal ports	
Conducted RF immunity	IEC 61000-4-6: 10V rms with 1 kHz sine wave 80% AM from 150 kHz...80 MHz	

(1) Up to 86.4 g/(m2.yr), mass loss of copper due to corrosion.

(2) Up to 2100 angstroms of film growth per 30 days of copper and/or silver reactivity.

Table 53. Certifications - PointMax Analog I/O Modules

Certification ⁽¹⁾	5034-IF8C, 5034-IF8CXT, 5034-IF8V, 5034-IF8VXT, 5034-IF4, 5034-IF4XT, 5034-IF4IH, 5034-IF4IHXT, 5034-IRT4I, 5034-IRT4IXT, 5034-OF4, 5034-OF4XT, 5034-OF4IH, 5034-OF4IHXT
c-UL-us	UL Listed Industrial Control Equipment, certified for US and Canada. See UL File E322657. UL Listed for Class I, Division 2 Group A,B,C,D Hazardous Locations, certified for U.S. and Canada. See UL File E334470.
UK and CE	UK Statutory Instrument 2016 No. 1091 and European Union 2014/30/EU EMC Directive, compliant with: EN 61326-1; Meas./Control/Lab., Industrial Requirements EN 61000-6-2; Industrial Immunity EN 61000-6-4; Industrial Emissions EN 61131-2; Programmable Controllers (Clause 8, Zone A & B) UK Statutory Instrument 2016 No. 1101 and European Union 2014/35/EU LVD, compliant with: EN 61010-2-201; Control Equipment Safety Requirements UK Statutory Instrument 2012 No. 3032 and European Union 2011/65/EU RoHS, compliant with: EN IEC 63000; Technical documentation
RCM	Australian Radiocommunications Act, compliant with:

Table 53. Certifications - PointMax Analog I/O Modules (continued)

Certification ⁽¹⁾	5034-IF8C, 5034-IF8CXT, 5034-IF8V, 5034-IF8VXT, 5034-IF4, 5034-IF4XT, 5034-IF4IH, 5034-IF4IHXT, 5034-IRT4I, 5034-IRT4IXT, 5034-OF4, 5034-OF4XT, 5034-OF4IH, 5034-OF4IHXT
	EN 61000-6-4; Industrial Emissions
Ex	UK Statutory Instrument 2016 No. 1107 and European Union 2014/34/EU ATEX Directive, compliant with: EN IEC 60079-0; General Requirements EN IEC 60079-7; Explosive Atmospheres, Protection "e" II 3 G Ex ec IIC T4 Gc UL 24 ATEX 3272X and UL24UKEX2997X
IECEX	IECEX System, compliant with: IEC 60079-0; General Requirements IEC 60079-7; Explosive Atmospheres, Protection "e" II 3 G Ex ec IIC T4 Gc IECEX UL 24.0066X
KC	Korean Registration of Broadcasting and Communications Equipment, compliant with: Article 58-2 of Radio Waves Act, Clause 4
Morocco	Arrêté ministériel n° 6404-15 du 1 er muharram 1437 Arrêté ministériel n° 6404-15 du 29 ramadan 1436
CCC	CNCA-C23-01 强制性产品认证实施规则 防爆电气 CNCA-C23-01 CCC Implementation Rule Explosion-Proof Electrical Products 2025122309123247

(1) When marked. See the Product Certifications website at rok.auto/certifications for declarations of conformity, certificates, and other certification details.

Specialty I/O Module

I/O Type	Catalog Number	Description
IO-Link Master	5034-IOL4, 5034-IOL4XT	IO-Link master 4-channel
Serial Interface	5034-SERIAL, 5034-SERIALXT	Serial RS-232/RS-422/RS-485 1 channel
Encoder	5034-ENC, 5034-ENCXT	HSC/SSI encoder 1 channel

Environmental specifications and certifications for PointMax specialty I/O modules are provided in [Environmental Specifications and Certifications on page 130](#).

5034-IOL4 and 5034-IOL4XT IO-Link Master 4-channel Module

Figure 51. 5034-IOL4 and 5034-IOL4XT Wiring Diagram - IO-Link Mode

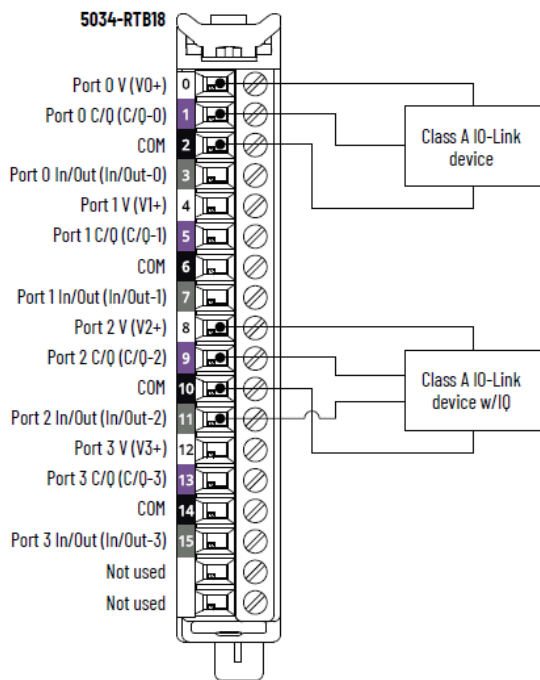

- C/Q = For IO-Link communication, digital input, or digital output
- In/Out (I/O) = For digital input or digital output

Figure 52. 5034-IOL4 and 5034-IOL4XT Wiring Diagram – DI Mode

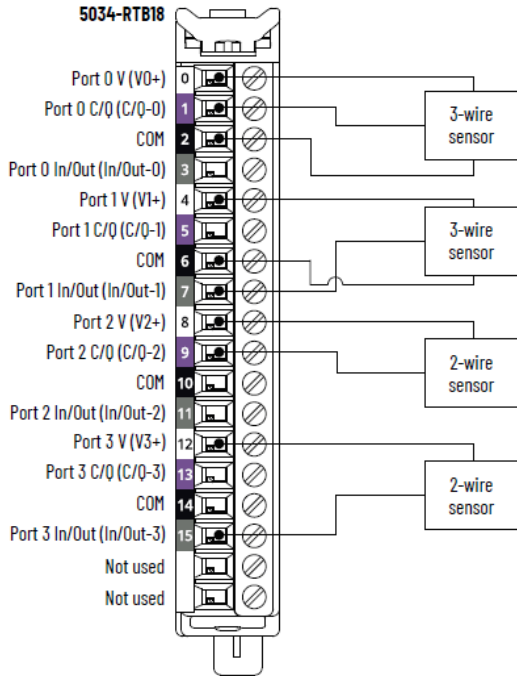

- C/Q = For IO-Link communication, digital input, or digital output
- In/Out (I/O) = For digital input or digital output

Figure 53. 5034-IOL4 and 5034-IOL4XT Wiring Diagram – DO Mode

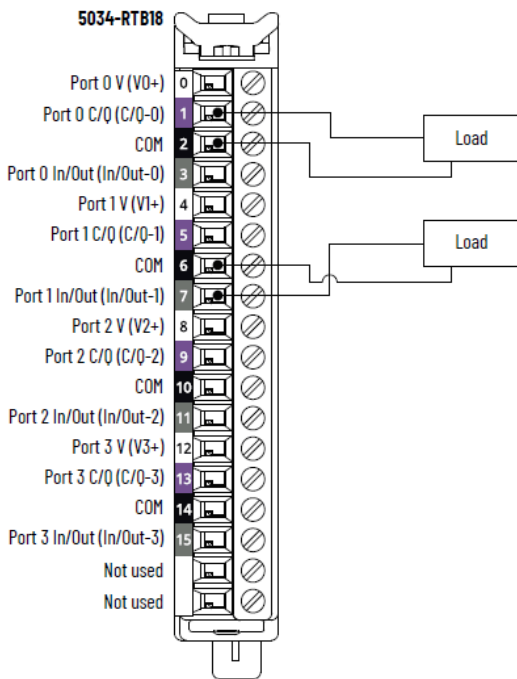

- C/Q = For IO-Link communication, digital input, or digital output
- In/Out (I/O) = For digital input or digital output

Figure 54. 5034-IOL4 and 5034-IOL4XT Functional Block Diagram

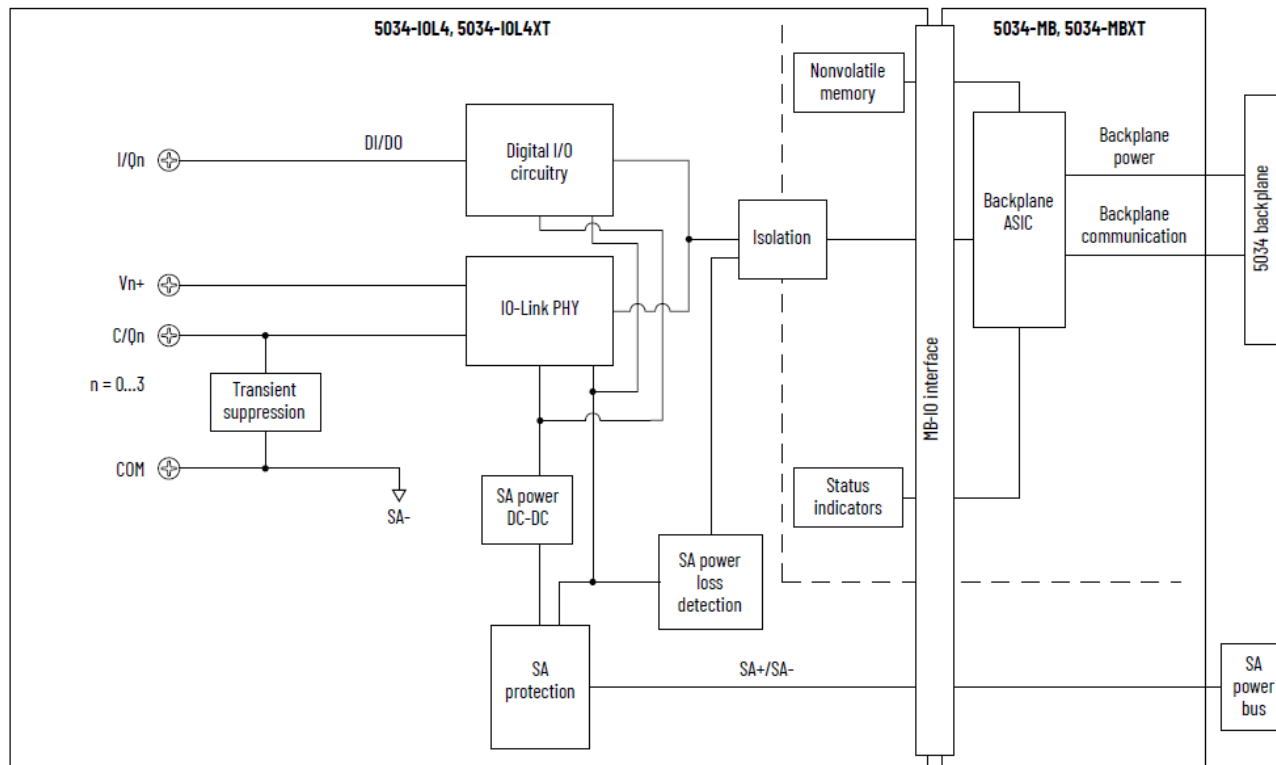

Table 54. Technical Specifications - 5034-IOL4, 5034-IOL4XT - IO-Link Ports

Attribute	5034-IOL4, 5034-IOL4XT
Number of ports	4 Class A ports
Communication speed	4.8 Kbps, 38.4 Kbps, 230.4 Kbps
Voltage rating	20...30V DC
V+ current rating, per port, max	0.5 A
IO-Link device cable length, max	20 m (66 ft)
IO-Link Protocol version	Versions 1.0 and 1.1

Table 55. Technical Specifications - 5034-IOL4, 5034-IOL4XT - Digital Inputs

Attribute	5034-IOL4, 5034-IOL4XT
On-state voltage range Channel 0, 2, 4, 6	11...30V DC - C/Q (in SIO mode)
On-state voltage range Channel 1, 3, 5, 7	10...30V DC - I/Q
On-state current, min	2 mA - C/Q (in SIO mode)

Table 55. Technical Specifications - 5034-IOL4, 5034-IOL4XT - Digital Inputs (continued)

Attribute	5034-IOL4, 5034-IOL4XT
Channel 0, 2, 4, 6	
On-state current, min Channel 1, 3, 5, 7	2 mA - I/Q
On-state current, nom Channel 0, 2, 4, 6	2.5 mA - C/Q (in SIO mode)
On-state current, nom Channel 1, 3, 5, 7	2.3 mA - I/Q
On-state current, max Channel 0, 2, 4, 6	6.6 mA - C/Q (in SIO mode)
On-state current, max Channel 1, 3, 5, 7	5 mA - I/Q
Off-state voltage, max Channel 0, 2, 4, 6	5V DC - C/Q (in SIO mode)
Off-state voltage, max Channel 1, 3, 5, 7	5V DC - I/Q
Off-state current, max Channel 0, 2, 4, 6	1.5 mA - C/Q (in SIO mode)
Off-state current, max Channel 1, 3, 5, 7	1.5 mA - I/Q
Input impedance, min	1.6 k Ω @ 11V DC - C/Q (in SIO mode) 2 k Ω @ 10V DC - I/Q
Input impedance, nom	9.6 k Ω @ 24V DC - C/Q (in SIO mode) 10.4 k Ω @ 24V DC - I/Q
Input impedance, max	15 k Ω @ 30V DC - C/Q (in SIO mode) 15 k Ω @ 30V DC - I/Q
Input delay time (screw to backplane), max Channel 0, 2, 4, 6 Off-to-On On-to-Off	900 μ s
Input delay time (screw to backplane), max Channel 1, 3, 5, 7	60 μ s

Table 55. Technical Specifications - 5034-IOL4, 5034-IOL4XT - Digital Inputs (continued)

Attribute	5034-IOL4, 5034-IOL4XT
Off-to-On On-to-Off	
Input min pulse width Channel 0, 2, 4, 6 Off-to-On On-to-Off	1 ms
Input min pulse width Channel 1, 3, 5, 7 Off-to-On On-to-Off	0.125 ms
Input filter time Channel 0, 2, 4, 6 Off-to-On On-to-Off	0 μ s, 2 ms (Default), 5 ms, 10 ms, 20 ms, 50 ms
Input filter time Channel 1, 3, 5, 7 Off-to-On On-to-Off	0 μ s, 100 μ s, 200 μ s, 500 μ s (Default), 1 ms, 2 ms, 5 ms, 10 ms, 20 ms, 50 ms The 0 μ s setting is embedded with a 10 μ s filter.
Simple counters, counter frequency Channel 0, 2, 4, 6	$0 \dots f_{\max} = 500$ Hz
Simple counters, counter frequency Channel 1, 3, 5, 7	$0 \dots f_{\max} = 4000$ Hz
Timestamp of inputs (sequence of events) Channel 0, 2, 4, 6	Yes, ± 500 μ s accuracy
Timestamp of inputs (sequence of events) Channel 1, 3, 5, 7	Yes, ± 10 μ s accuracy
Events	Yes
Pattern matching	Yes

Table 56. Technical Specifications - 5034-IOL4, 5034-IOL4XT - Digital Outputs

Attribute	5034-IOL4, 5034-IOL4XT
On-state voltage range	20...30V DC - C/Q (in SIO mode)

Table 56. Technical Specifications - 5034-IOL4, 5034-IOL4XT - Digital Outputs (continued)

Attribute	5034-IOL4, 5034-IOL4XT
Channel 0, 2, 4, 6	
On-state voltage range Channel 1, 3, 5, 7	20...30V DC - I/Q
On-state voltage drop, max Channel 0, 2, 4, 6	0.6V DC - C/Q (in SIO mode)
On-state voltage drop, max Channel 1, 3, 5, 7	0.3V DC - I/Q
On-state current per channel, max Channel 0, 2, 4, 6	250 mA - C/Q (in SIO mode)
On-state current per channel, max Channel 1, 3, 5, 7	500 mA - I/Q
Off-state leakage current per point, max Off-state open wire detection disabled Channel 1, 3, 5, 7 only	0.1 mA
Off-state leakage current per point, max ⁽¹⁾ Off-state open wire detection enabled Channel 1, 3, 5, 7 only	0.5 mA
Surge current per output, max Channel 1, 3, 5, 7	1 A for 10 ms, repeatable every 3 s
Output current rating per module, max	3 A
Output delay time (backplane to screw), max Channel 0, 2, 4, 6 Off-to-On On-to-Off	1 ms
Output delay time (backplane to screw), max Channel 1, 3, 5, 7 Off-to-On On-to-Off	0.15 ms
Open load detection diagnostics Channel 1, 3, 5, 7 only	Yes, configurable (Default is off)
Output short circuit/overload detection	Yes

Table 56. Technical Specifications - 5034-IOL4, 5034-IOL4XT - Digital Outputs (continued)

Attribute	5034-IOL4, 5034-IOL4XT
Channel 0, 2, 4, 6	
Output short circuit/overload detection Channel 1, 3, 5, 7	Yes

(1) Recommended Loading Resistor - To limit the effects of leakage current through solid-state outputs, you can connect a loading resistor in parallel with your load. For 24V DC operation, use a 5.6 kΩ, 0.5 W resistor for transistor operation.

Table 57. General Specifications - 5034-IOL4, 5034-IOL4XT

Attribute	5034-IOL4, 5034-IOL4XT
Number of inputs/outputs	8 channels, configurable, inclusive of 4x C/Q channels configured to SIO mode, sinking input, sourcing output
SA power voltage, nom	24V DC
SA power voltage range	20...30V DC
SA power current, nom	3.2 A
SA power current, max	3.3 A
SA power current at no load	14 mA
SA reverse polarity protection	Yes
Power dissipation, max ⁽¹⁾	1.04 W
Thermal dissipation, max ⁽¹⁾	3.55 BTU/hr
Isolation voltage	250V (continuous), Basic Insulation Type, System to Field No isolation between SA power and channels No isolation between individual channels
RIUP support	Yes
CIP Sync	Yes, slave only ordinary clock
Electronic keying	Electronic keying via programming software
RTB key positions (slot)	3, 6, 12
RTB supported	5034-RTB18, 5034-RTB18S
Wiring category ⁽²⁾	2 - Signal ports 2 - Power ports
Wiring specification	See Wiring Specifications for Removable Terminal Blocks in the PointMax I/O System Specifications Technical Data, publication 5034-TD001

Table 57. General Specifications - 5034-IOL4, 5034-IOL4XT (continued)

Attribute	5034-IOL4, 5034-IOL4XT
Indicators	1 green/red module status indicator 1 green/red SA power status indicator 8 yellow/red I/O status indicators
Dimensions (HxWxD), approx	123.6 x 15.0 x 66.4 mm (4.87 x 0.59 x 2.61 in.)
Weight, approx	48.0 g (1.69 oz.) - 5034-IOL4 51.0 g (1.80 oz.) - 5034-IOL4XT
Enclosure type	None (Open-style)
North American temp code	T4
UKEX/ATEX temp code	T4
IECEx temp code	T4

(1) Value is measured at 60 °C (140 °F). Power dissipation varies with temperature.

(2) Use this Conductor Category information for planning conductor routing. See the Industrial Automation Wiring and Grounding Guidelines, publication [1770-4.1](#). Use this Conductor Category information for planning conductor routing as described in the appropriate System Level Installation Manual.

5034-SERIAL and 5034-SERIALXT Serial RS-232/RS-422/RS-485 1 Channel Module

Figure 55. 5034-SERIAL and 5034-SERIALXT Wiring Diagram – RS-232 Mode DTE Device

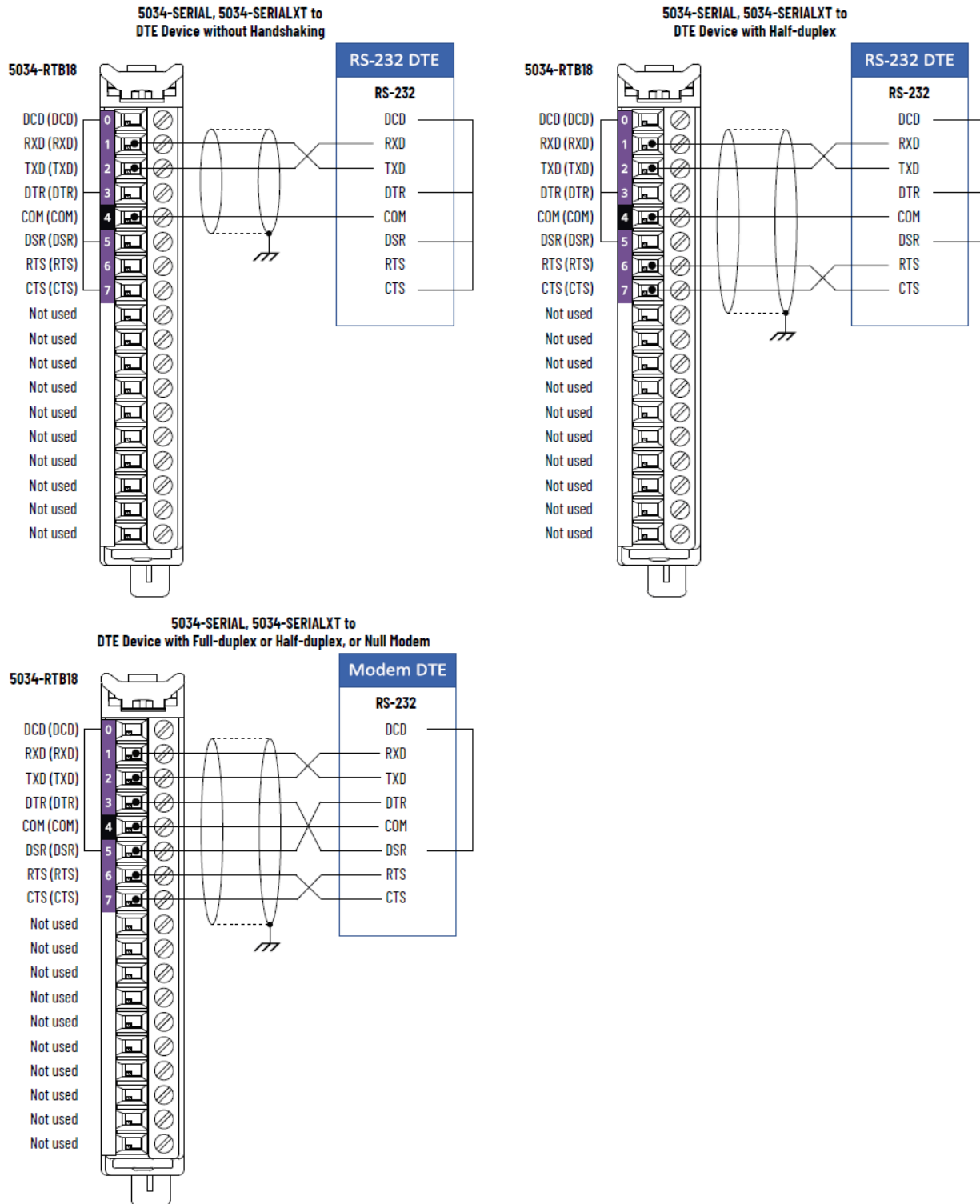

Figure 56. 5034-SERIAL and 5034-SERIALXT Wiring Diagram - RS-232 Mode DCE Device

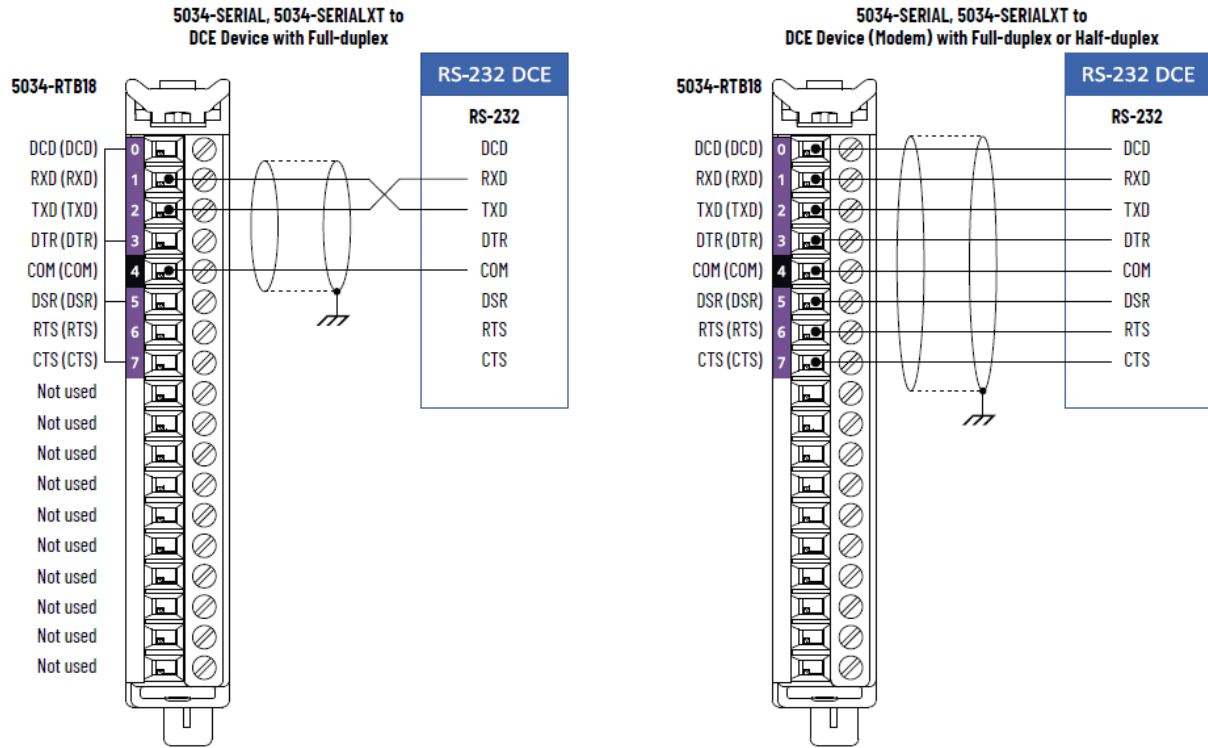
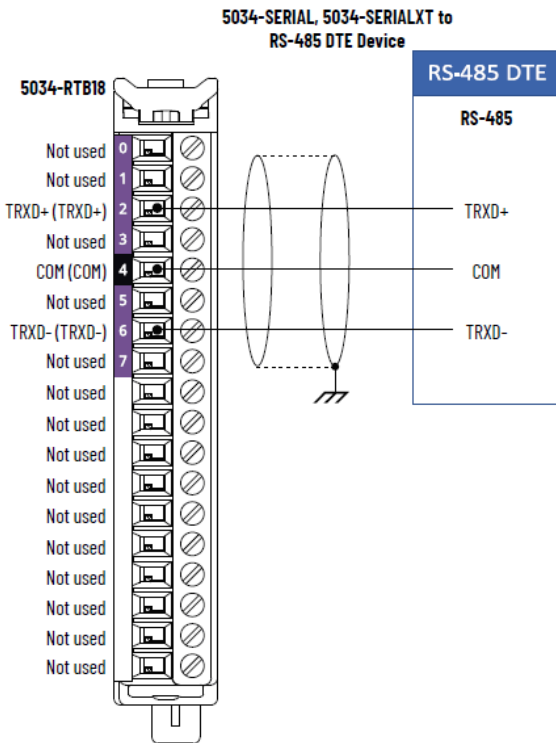

Figure 57. 5034-SERIAL and 5034-SERIALXT Wiring Diagram - RS-485 Mode



IMPORTANT:

- Place the termination resistor between TRXD+ and TRXD- to implement this wiring.
- The recommended cable to use is Belden 8104.

Figure 58. 5034-SERIAL and 5034-SERIALXT Wiring Diagram – RS-422 Mode

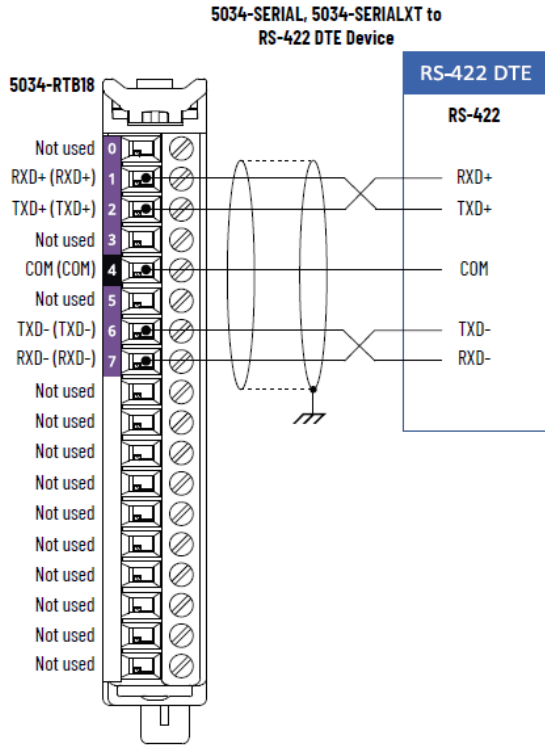

IMPORTANT:

- Place the termination resistor between RXD+ and RXD- to implement this wiring.
- The recommended cable to use is Belden 8104.

Figure 59. 5034-SERIAL and 5034-SERIALXT Functional Block Diagram

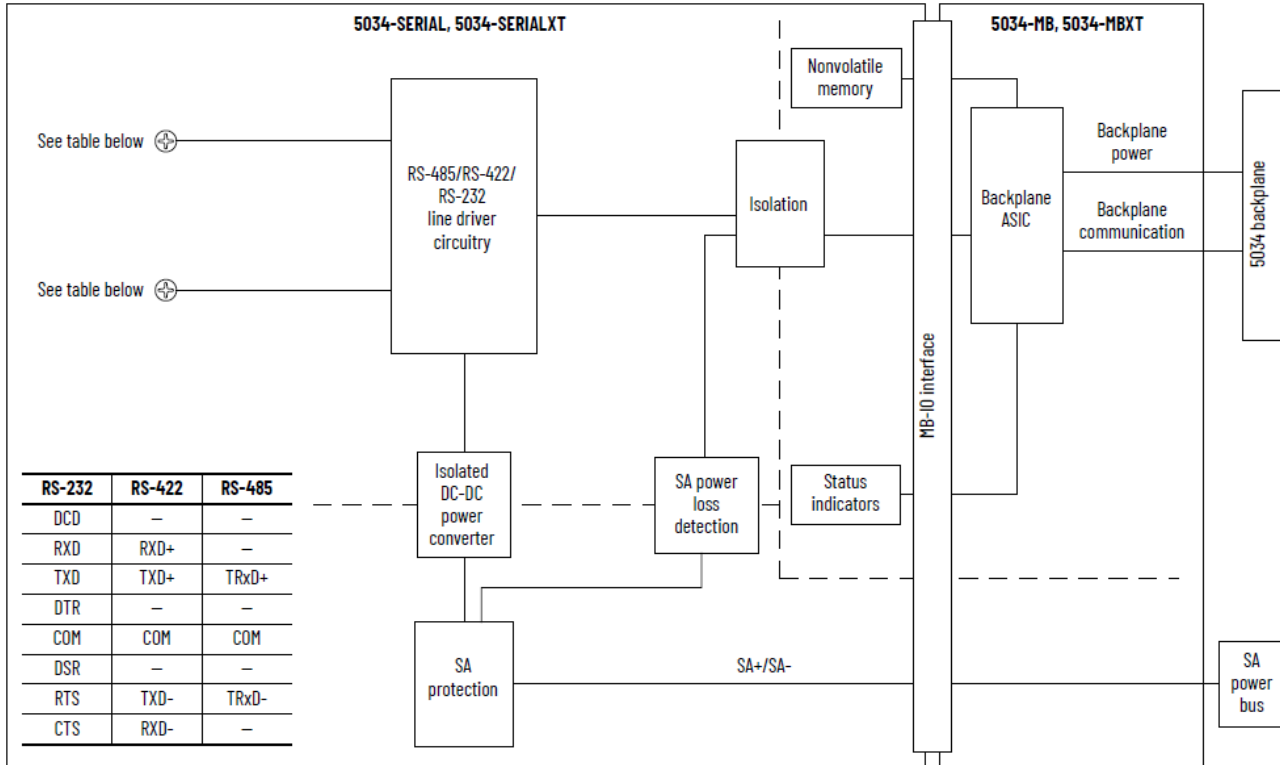

Table 58. Technical Specifications - 5034-SERIAL, 5034-SERIALXT

Attribute	5034-SERIAL, 5034-SERIALXT
Operating modes	Generic ASCII Modbus RTU Modbus ASCII
Serial input signal voltage range	+3...+25V DC regarding signal ground (SG) 0, Asserted, ON, Space, Active -3...-25V DC regarding signal ground (SG) 1, Deasserted, OFF, Mark, Inactive
Handshaking	RTS/CTS hardware handshake always enabled RTS/CTS user-controllable
Supported communication rate (bps)	1200, 2400, 4800, 9600, 19200 (Default), 38400, 57600, 115200

Table 59. General Specifications - 5034-SERIAL, 5034-SERIALXT

Attribute	5034-SERIAL, 5034-SERIALXT
Number of inputs	One full-duplex (RS-232, RS-422)/half-duplex (RS-485)
Voltage category	24V DC source
SA power voltage, nom	24V DC

Table 59. General Specifications - 5034-SERIAL, 5034-SERIALXT (continued)

Attribute	5034-SERIAL, 5034-SERIALXT
SA power voltage range	10...30V DC
SA power current, nom	20 mA
SA power current, max	30 mA
SA power current at no load	15 mA
SA reverse polarity protection	Yes
Power dissipation, max ⁽¹⁾	0.55 W
Thermal dissipation, max ⁽¹⁾	1.88 BTU/hr
Isolation voltage	250V (continuous), Basic Insulation Type, System to SA power 250V (continuous), Basic Insulation Type, SA power to Communication channel 250V (continuous), Basic Insulation Type, System to Communication channel
RIUP support	Yes
Electronic keying	Electronic keying via programming software
RTB key positions (slot)	3, 5, 11
RTB supported	5034-RTB18, 5034-RTB18S
Wiring category ⁽²⁾	2 - Signal ports 2 - Power ports
Wiring specification	See Wiring Specifications for Removable Terminal Blocks in the PointMax I/O System Specifications Technical Data, publication 5034-TD001
Indicators	1 green/red module status indicator 1 green/red SA power status indicator 2 yellow/red I/O status indicators
Dimensions (HxWxD), approx	123.6 x 15.0 x 66.4 mm (4.87 x 0.59 x 2.61 in.)
Weight, approx	45.0 g (1.59 oz.) - 5034-SERIAL 47.0 g (1.66 oz.) - 5034-SERIALXT
Enclosure type	None (Open-style)
North American temp code	T4
UKEX/ATEX temp code	T4
IECEx temp code	T4

Table 59. General Specifications - 5034-SERIAL, 5034-SERIALXT (continued)

Attribute	5034-SERIAL, 5034-SERIALXT
-----------	----------------------------

(1) Value is measured at 60 °C (140 °F). Power dissipation varies with temperature.

(2) Use this Conductor Category information for planning conductor routing. See the Industrial Automation Wiring and Grounding Guidelines, publication [1770-4.1](#). Use this Conductor Category information for planning conductor routing as described in the appropriate System Level Installation Manual.

5034-ENC and 5034-ENCXT HSC/SSI Encoder 1 Channel Module

Figure 60. 5034-ENC and 5034-ENCXT Wiring Diagram - HSC/Incremental Encoder

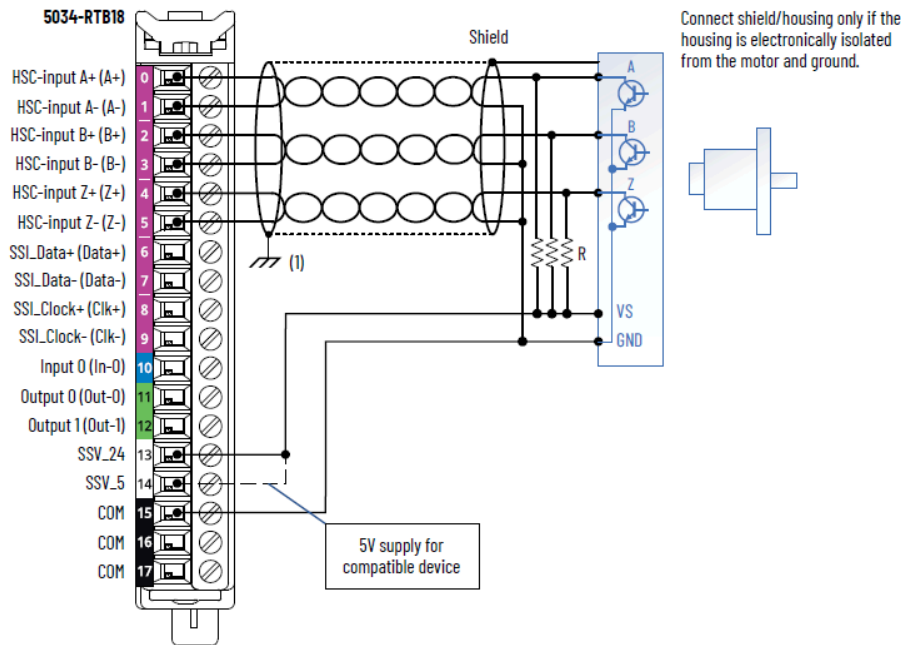

(1) If the module is installed on a DIN rail that is grounded, you can connect the cable shield to the terminal labeled Chassis instead of Earth Ground.

IMPORTANT: When using the module in HSC mode, do not connect wiring to the SSI terminals (Data, Clk).

IMPORTANT: External resistors, as indicated by the “R” in the diagram, are required if they are not internal to the encoder. The pull-up resistor (R) value depends on the power supply value.

To calculate the maximum resistor value, use the following formula:

$$R = VDC - V_{min} / I_{min}$$

Where:

- R = Maximum pull-up resistor value
- VDC = Power supply voltage (either SSV_24 or SSV_5)
- $V_{min} = 3.0V$ DC
- $I_{min} = 2.5$ mA

Supply By	Power Supply Voltage (V DC)	Pull-up Resistor Value (R), Max (Ω) ⁽¹⁾
SSV_24	10	2800
	24	8400
	30	10,800
SSV_5	5	800

(1) Resistance values can change, depending on your application. The minimum resistor (R) value depends on the current-sinking capability of the encoder.

Figure 61. 5034-ENC and 5034-ENCXT Wiring Diagram – SSI Encoder

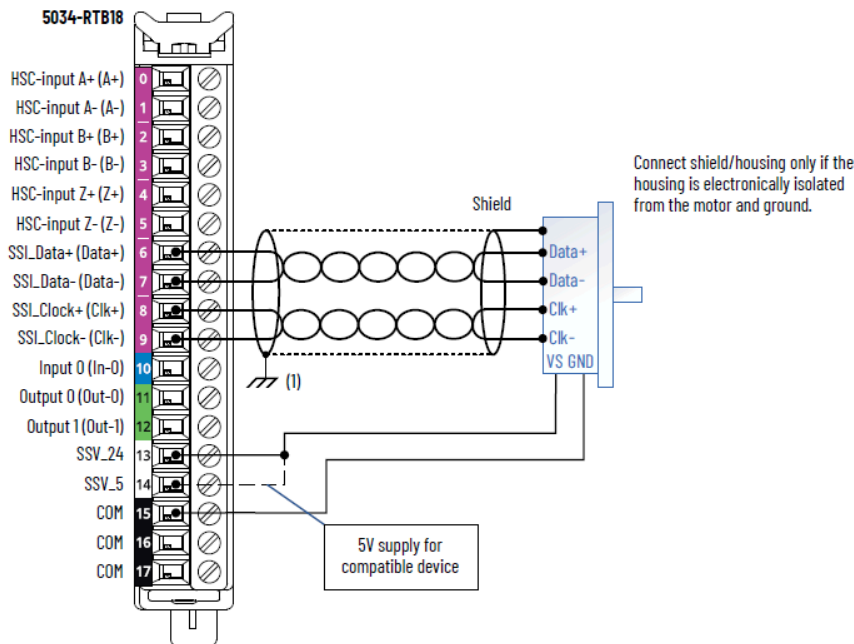

(1) If the module is installed on a DIN rail that is grounded, you can connect the cable shield to the terminal labeled Chassis instead of Earth Ground.

IMPORTANT: When using the module in SSI mode, do not connect wiring to the HSC terminals (A, B, Z).

Figure 62. 5034-ENC and 5034-ENCXT Wiring Diagram - Input/Output

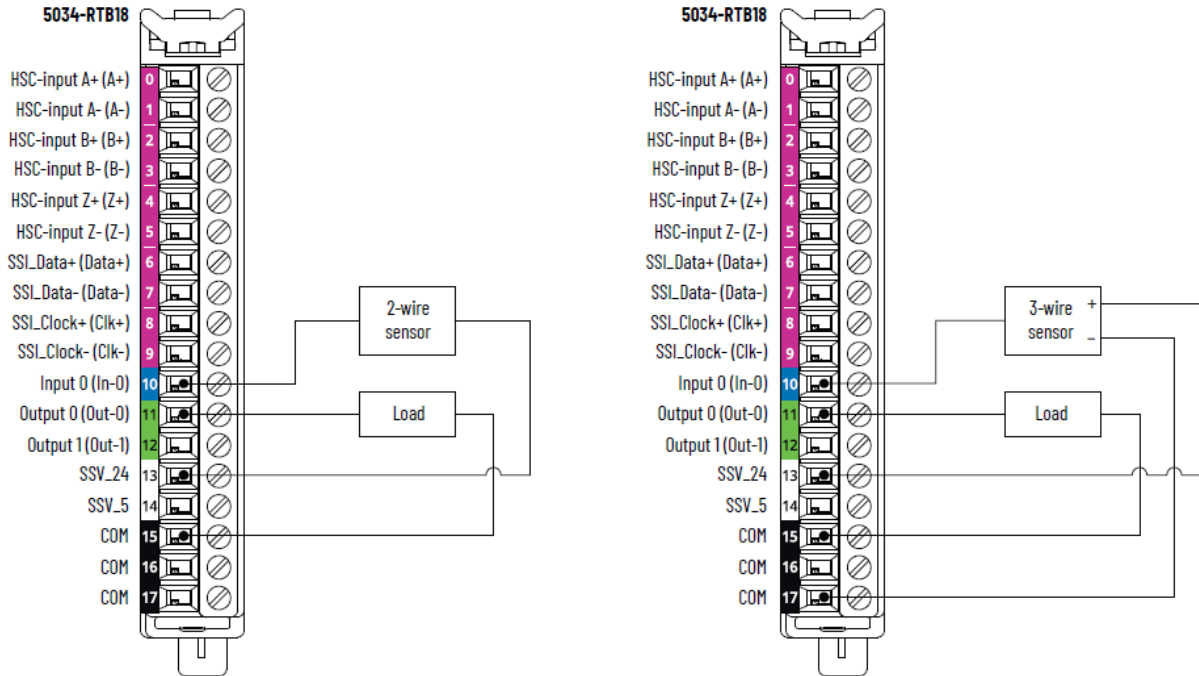

Figure 63. 5034-ENC and 5034-ENCXT Functional Block Diagram

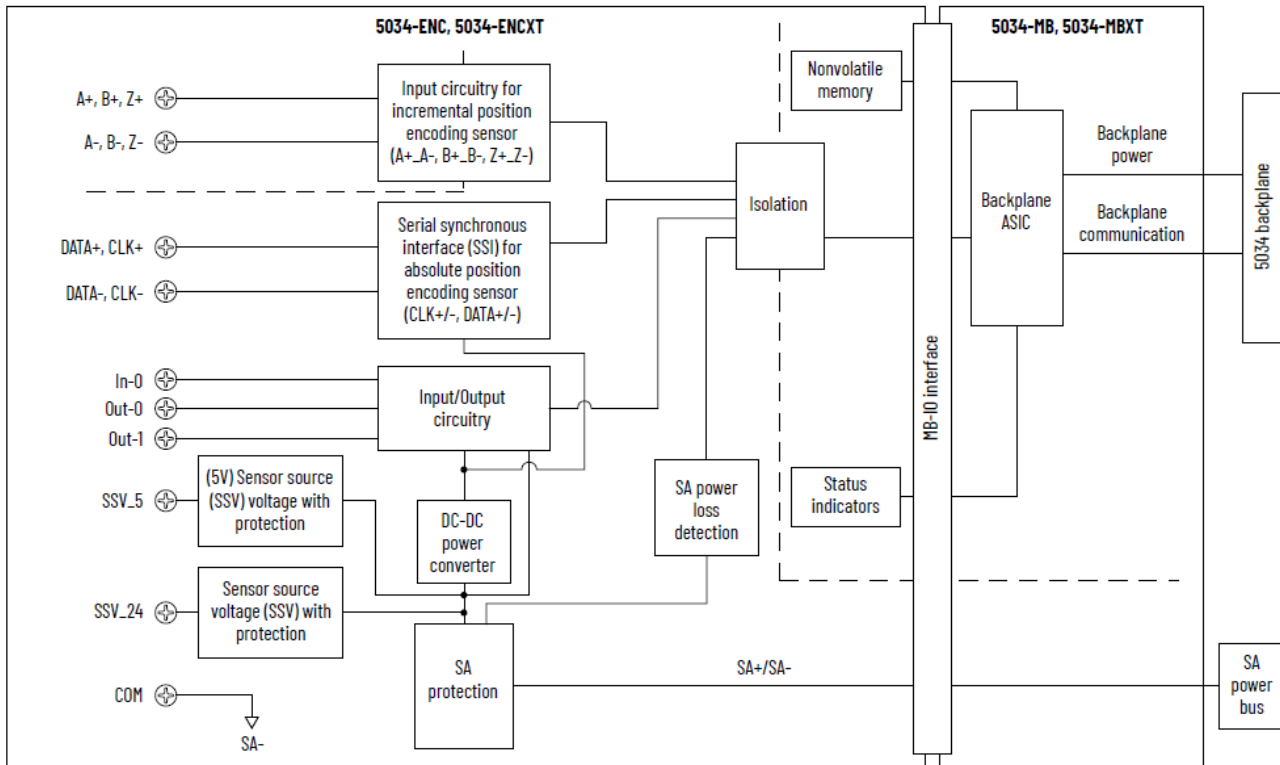

Table 60. Technical Specifications - 5034-ENC, 5034-ENCXT - HSC

Attribute	5034-ENC, 5034-ENCXT
On-state voltage range	3...32V DC

Table 60. Technical Specifications - 5034-ENC, 5034-ENCXT - HSC (continued)

Attribute	5034-ENC, 5034-ENCXT
Channel A, B, Z	
On-state current, min Channel A, B, Z	2.5 mA @ 3V DC
On-state current, nom Channel A, B, Z	4.0 mA @ 24V DC
On-state current, max Channel A, B, Z	8.0 mA @ 32V DC
Off-state voltage, max Channel A, B, Z	1.5V DC
Off-state current, max Channel A, B, Z	0.5 mA
Input pulse width, min Off-to-On On-to-Off	125 ns
Input filter time Off-to-On On-to-Off	0 ns, 100 ns, 200 ns, 500 ns, 1 μ s, 2 μ s, 5 μ s (Default for Input A and Input B), 10 μ s, 20 μ s, 50 μ s, 100 μ s, 200 μ s, 500 μ s, 1 ms (Default for Input Z), 2 ms, 5 ms, 10 ms, 20 ms, 50 ms
Phase separation, min	100 ns
Input pulse frequency, max	1.0 MHz
Input pulse frequency, min	0.1 Hz

Table 61. Technical Specifications - 5034-ENC, 5034-ENCXT - SSI

Attribute	5034-ENC, 5034-ENCXT
SSI mode encoder type	Any absolute encoder supporting standard SSI protocol including linear, rotary, and optical distance measuring devices in MSB-aligned data format The physical interface for clock and data signals is RS-422.
SSI data rate supported	125 kHz (Default), 250 kHz, 500 kHz, 1 MHz, 2 MHz
SSI bits per word supported	2...31 bits 13 bits (Default)
SSI word delay time	16...65,535 μ s

Table 61. Technical Specifications - 5034-ENC, 5034-ENCXT - SSI (continued)

Attribute	5034-ENC, 5034-ENCXT
	64 μ s (Default)
SSI code type supported	Binary, Gray (Gray to binary conversion supported)
SSI direction	Increasing or decreasing SSI count indication
SSI data comparator	Up to four window comparators
SSI data latching	Supported using In-0 input
SSI cable type	UL CM/AWM 2464/CSA Type CMG FT4 or similar cable utilizing shielded twisted pairs for D+/- and C+/- connections. See sensor manufacturer for actual cable required for the SSI sensor under use. In-0 input can be separate from SSI cable.
SSI cable length, max	Depending on the desired SSI data rate: 125 kHz - 320 m (1050 ft) 250 kHz - 160 m (525 ft) 500 kHz - 60 m (195 ft) 1 MHz - 20 m (65 ft) 2 MHz - 8 m (25 ft)

Table 62. Technical Specifications - 5034-ENC, 5034-ENCXT - Digital Input

Attribute	5034-ENC, 5034-ENCXT
On-state voltage range	10...30V DC
On-state current, min	2.0 mA
On-state current, nom	4.5 mA
On-state current, max	5.0 mA
Off-state voltage, max	5V DC
Off-state current, max	1.5 mA
Input impedance, min	2 k Ω @ 10V DC
Input impedance, nom	5.3 k Ω @ 24V DC
Input impedance, max	15 k Ω @ 30V DC
Input delay time (screw to backplane), max	150 μ s
Off-to-On	
On-to-Off	
Input pulse width, min	10 μ s

Table 62. Technical Specifications - 5034-ENC, 5034-ENCXT – Digital Input (continued)

Attribute	5034-ENC, 5034-ENCXT
Off-to-On On-to-Off	
Input filter time Off-to-On On-to-Off	0 ns, 10 μ s, 20 μ s, 50 μ s, 100 μ s, 200 μ s, 500 μ s, 1 ms (Default), 2 ms, 5 ms, 10 ms, 20 ms, 50 ms
Timestamp of inputs (sequence of events)	Not supported

Table 63. Technical Specifications - 5034-ENC, 5034-ENCXT – Digital Output

Attribute	5034-ENC, 5034-ENCXT
On-state voltage range	10...30V DC
On-state voltage drop, max	0.25V DC
On-state current per point, min	1.0 mA
Off-state voltage, max	5V DC with 1 mA min load
Off-state leakage current per point, max ⁽¹⁾	0.5 mA
Output current rating per channel, max	0.5 A
Output current rating per module, max	1 A
Surge current per point, max	1.2 A for 10 ms, repeatable every 3 s
Inductive load allowed, max	1.2 H
Output clamping voltage for inductive load when turn off	(SA voltage + VCL)...0 VCL value: Minimum is -63V, Typical is -55V, Maximum is -49V
Output delay time (backplane to screw), max Off-to-On On-to-Off	150 μ s
PWM/PTO support	Yes Maximum switching frequency: 100 kHz (10 μ s period) Minimum switching frequency: 0.033 Hz (30 s period) Minimum pulse width: 5 μ s Maximum load current (resistive type) per point: <ul style="list-style-type: none"> • 200 mA for $F_{sw} \leq 10$ kHz • 100 mA for 10 kHz $< F_{sw} \leq 25$ kHz • 40 mA for 25 kHz $< F_{sw} \leq 100$ kHz

Table 63. Technical Specifications - 5034-ENC, 5034-ENCXT – Digital Output (continued)

Attribute	5034-ENC, 5034-ENCXT
	Where F_{sw} is the switching frequency
Triggered pulse output support	Yes
Open load detection diagnostics	Not supported
Output short circuit/overload detection	Yes
Output short circuit/overload protection	Yes
Pilot duty rating	1.2 A inrush current, 0.5 A rated current, DC-14
Output states in program mode per point	Hold Last State On Off (Default) Local Control
Output states in communication fault mode per point	Hold Last State On Off (Default) Local Control
Duration of fault mode per point	1 s 2 s 5 s 10 s Forever (Default)
Output final state after fault mode per point	On Off (Default)

(1) Recommended loading resistor - To limit the effects of leakage current through solid-state outputs, you can connect a loading resistor in parallel with your load. For 24V DC operation, use a 5.6 kΩ, 0.5 W resistor for transistor operation.

Table 64. General Specifications - 5034-ENC, 5034-ENCXT

Attribute	5034-ENC, 5034-ENCXT
Number of HSC	1 group of A+/A-, B+/B-, and Z+/Z-
Number of SSI	1 group of Data+/Data- and Clock+/Clock-
Number of inputs	1 channel, sinking
Number of outputs	2 channels, sourcing

Table 64. General Specifications - 5034-ENC, 5034-ENCXT (continued)

Attribute	5034-ENC, 5034-ENCXT
SA power voltage, nom	24V DC
SA power voltage range	10...30V DC
SA power current, nom	1.6 A
SA power current, max	1.7 A
SA power current at no load	12 mA
SA reverse polarity protection	Yes
SSV voltage range, SSV_24	Follow SA power supply
SSV voltage range, SSV_5	5V (±5%)
SSV current, SSV_24, max	500 mA
SSV current, SSV_5, max	300 mA
SSV short-circuit protection, SSV_24	Yes
SSV short-circuit protection, SSV_5	Yes
Power dissipation, max ⁽¹⁾	1.22 W
Thermal dissipation, max ⁽¹⁾	4.16 BTU/hr
Isolation voltage	250V (continuous), Basic Insulation Type, System to Field 250V (continuous), Basic Insulation Type, HSC input to other Field side 250V (continuous), Basic Insulation Type, HSC input to System No isolation between SA power and Digital input/output points No isolation between SA power and SSI ports No isolation between SA power and SSV_24/SSV_5 No isolation between individual Digital input/output points
RIUP support	Yes
CIP Sync	Slave only ordinary clock
Electronic keying	Electronic keying via programming software
RTB key positions (slot)	3, 7, 12
RTB supported	5034-RTB18, 5034-RTB18S
Wiring category ⁽²⁾	2 - Signal ports 2 - Power ports

Table 64. General Specifications - 5034-ENC, 5034-ENCXT (continued)

Attribute	5034-ENC, 5034-ENCXT
Wiring specification	See Wiring Specifications for Removable Terminal Blocks in the PointMax I/O System Specifications Technical Data, publication 5034-TD001
Indicators	1 green/red module status indicator 1 green/red SA power status indicator 5 yellow/red I/O status indicators 1 yellow I/O status indicator
Dimensions (HxWxD), approx	123.6 x 15.0 x 66.4 mm (4.87 x 0.59 x 2.61 in.)
Weight, approx	45.0 g (1.59 oz.) - 5034-ENC 47.0 g (1.66 oz.) - 5034-ENCXT
Enclosure type	None (Open-style)
North American temp code	T4
UKEX/ATEX temp code	T4
IECEx temp code	T4

(1) Value is measured at 60 °C (140 °F). Power dissipation varies with temperature.

(2) Use this Conductor Category information for planning conductor routing. See the Industrial Automation Wiring and Grounding Guidelines, publication [1770-4.1](#). Use this Conductor Category information for planning conductor routing as described in the appropriate System Level Installation Manual.

Environmental Specifications and Certifications

The following tables provide the environmental specifications and certifications for the PointMax specialty I/O modules.

Table 65. Environmental Specifications - PointMax Specialty I/O Modules

Attribute	5034-IOL4, 5034-SERIAL, 5034-ENC	5034-IOL4XT, 5034-SERIALXT, 5034-ENCXT
Temperature, operating	IEC 60068-2-1 (Test Ae, Operating Cold), IEC 60068-2-2 (Test Be, Operating Dry Heat), IEC 60068-2-14 (Test Nb, Operating Thermal Shock): -25 °C ≤ Ta ≤ +60 °C (-13 °F ≤ Ta ≤ +140 °F) for horizontal orientation -25 °C ≤ Ta ≤ +55 °C (-13 °F ≤ Ta ≤ +131 °F) for other orientations	
Temperature, surrounding air, max	60 °C (140 °F)	
Temperature, nonoperating	IEC 60068-2-1 (Test Ab, Unpackaged Nonoperating Cold), IEC 60068-2-2 (Test Bb, Unpackaged Nonoperating Dry Heat), IEC 60068-2-14 (Test Na, Unpackaged Nonoperating Thermal Shock):	

Table 65. Environmental Specifications - PointMax Specialty I/O Modules (continued)

Attribute	5034-IOL4, 5034-SERIAL, 5034-ENC	5034-IOL4XT, 5034-SERIALXT, 5034-ENCXT
	-40...+85 °C (-40...+185 °F)	
Relative humidity	IEC 60068-2-30 (Test Db, Unpackaged Damp Heat): 5...95% noncondensing	
Conformal coated	No	Yes
Corrosive Atmosphere ASTM B845-97 Method K Accelerated Test (20-Day Exposure)	Severity Level G3 ⁽¹⁾ per ANSI/ISA 71.04-2013, Airborne Contaminants—Gases	—
Corrosive Atmosphere • ASTM B845-97 Method K Accelerated Test (30-Day Exposure) • Plus additional Rockwell Automation proprietary accelerated corrosive environment test protocol for specific industries with sources of gaseous sulfur compounds.	—	Severity Level GX ⁽²⁾ per ANSI/ISA 71.04-2013, Airborne Contaminants—Gases Severity Level CX per IEC 60721-3-3:2019, Chemically Active Substances
Vibration	IEC 60068-2-6 (Test Fc, Operating): 5 g @ 10...500 Hz	
Shock, operating	IEC 60068-2-27 (Test Ea, Unpackaged Shock): 30 g	
Repetitive shock, operating	IEC 60068-2-27: 25 g, 6 ms duration, 1000 shocks in each ± direction in each 3 axis	
Shock, nonoperating	IEC 60068-2-27 (Test Ea, Unpackaged Shock): 50 g	
Emissions	IEC 61000-6-4	
ESD immunity	IEC 61000-4-2: 6 kV contact discharges 8 kV air discharges	
Radiated RF immunity	IEC 61000-4-3: 10V/m with 1 kHz sine wave 80% AM from 80...6000 MHz	
EFT/B immunity	IEC 61000-4-4:	

Table 65. Environmental Specifications - PointMax Specialty I/O Modules (continued)

Attribute	5034-IOL4, 5034-SERIAL, 5034-ENC	5034-IOL4XT, 5034-SERIALXT, 5034-ENCXT
	±3 kV @ 5 kHz on signal ports	
Surge transient immunity	IEC 61000-4-5: ±1 kV line-line (DM) and ±2 kV line-earth (CM) on signal ports	
Conducted RF immunity	IEC 61000-4-6: 10V rms with 1 kHz sine wave 80% AM from 150 kHz...80 MHz	

(1) Up to 86.4 g/(m2.yr), mass loss of copper due to corrosion.

(2) Up to 2100 angstroms of film growth per 30 days of copper and/or silver reactivity.

Table 66. Certifications - PointMax Specialty I/O Modules

Certification ⁽¹⁾	5034-IOL4, 5034-IOL4XT, 5034-SERIAL, 5034-SERIALXT, 5034-ENC, 5034-ENCXT
c-UL-us	UL Listed Industrial Control Equipment, certified for US and Canada. See UL File E322657. UL Listed for Class I, Division 2 Group A,B,C,D Hazardous Locations, certified for U.S. and Canada. See UL File E334470.
UK and CE	UK Statutory Instrument 2016 No. 1091 and European Union 2014/30/EU EMC Directive, compliant with: EN 61326-1; Meas./Control/Lab., Industrial Requirements EN 61000-6-2; Industrial Immunity EN 61000-6-4; Industrial Emissions EN 61131-2; Programmable Controllers (Clause 8, Zone A & B) UK Statutory Instrument 2016 No. 1101 and European Union 2014/35/EU LVD, compliant with: EN 61010-2-201; Control Equipment Safety Requirements UK Statutory Instrument 2012 No. 3032 and European Union 2011/65/EU RoHS, compliant with: EN IEC 63000; Technical documentation
RCM	Australian Radiocommunications Act, compliant with: EN 61000-6-4; Industrial Emissions
Ex	UK Statutory Instrument 2016 No. 1107 and European Union 2014/34/EU ATEX Directive, compliant with: EN IEC 60079-0; General Requirements EN IEC 60079-7; Explosive Atmospheres, Protection "e" II 3 G Ex ec IIC T4 Gc UL 24 ATEX 3272X and UL24UKEX2997X
IECEx	IECEx System, compliant with: IEC 60079-0; General Requirements IEC 60079-7; Explosive Atmospheres, Protection "e" II 3 G Ex ec IIC T4 Gc

Table 66. Certifications - PointMax Specialty I/O Modules (continued)

Certification ⁽¹⁾	5034-IOL4, 5034-IOL4XT, 5034-SERIAL, 5034-SERIALXT, 5034-ENC, 5034-ENCXT
	IECEX UL 24.0066X
KC	Korean Registration of Broadcasting and Communications Equipment, compliant with: Article 58-2 of Radio Waves Act, Clause 4
Morocco	Arrêté ministériel n° 6404-15 du 1 er muharram 1437 Arrêté ministériel n° 6404-15 du 29 ramadan 1436
CCC	CNCA-C23-01 强制性产品认证实施规则 防爆电气 CNCA-C23-01 CCC Implementation Rule Explosion-Proof Electrical Products 2025122309123247

(1) When marked. See the Product Certifications website at rok.auto/certifications for declarations of conformity, certificates, and other certification details.

Expansion Power

Module Type	Catalog Number	Description
Expansion Power	5034-EXP, 5034-EXPXT	Expansion power MOD and SA

Environmental specifications and certifications for PointMax expansion power are provided in [Environmental Specifications and Certifications on page 136](#).

5034-EXP and 5034-EXPXT Expansion Power MOD and SA

Figure 64. 5034-EXP and 5034-EXPXT Diagram

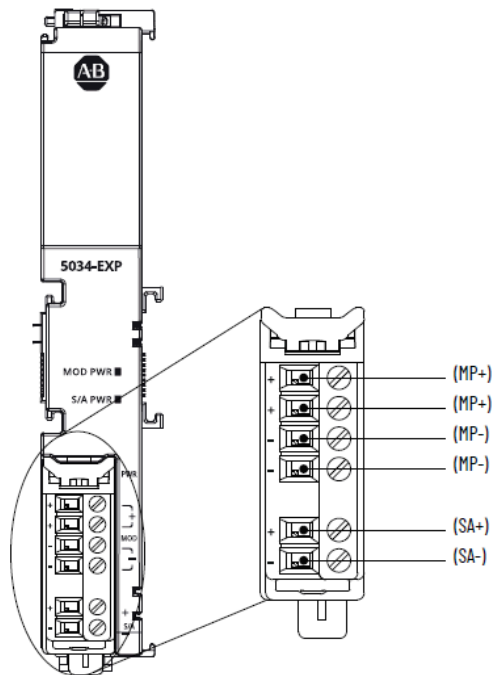

Table 67. General Specifications - 5034-EXP, 5034-EXPXT

Attribute	5034-EXP, 5034-EXPXT
Number of MB supported	16 for 18...30V DC 8 for 10...18V DC
MP voltage, nom	24V DC, SELV
MP voltage range	10...30V DC, SELV
MP current, nom	420 mA @ 24V DC
MP current, max	550 mA @ 10 V DC (8 MB) 590 mA @ 18 V DC (16 MB) 370 mA @ 30 V DC (16 MB)

Table 67. General Specifications - 5034-EXP, 5034-EXPXT (continued)

Attribute	5034-EXP, 5034-EXPXT
MP inrush current, max	6 A for 10 ms @ 24V DC SELV
SA power operating voltage range	10...30V DC, SELV
SA power current, max	10 A Do not exceed 10 A current draw at the SA power RTB.
SA power current at no load	2 mA
BP voltage	16V DC
BP current, max	250 mA (8 MB) 500 mA (16 MB)
Power dissipation, max	1.7 W
Thermal dissipation, max	5.8 BTU/hr
Isolation voltage	250V (continuous), Basic Isolation, SA to backplane 250V (continuous), Basic Isolation, SA to MP 60V (continuous), Basic Isolation, MP to backplane
RTB supported	An RTB ships with the expansion power. You can order additional screw-type (5034-AENRTB-QTY5) and push-in spring-type (5034-AENRTBS-QTY5) separately.
Wiring category ⁽¹⁾	2 - Power ports
Wiring specification	See Wiring Specifications for Removable Terminal Blocks in the PointMax I/O System Specifications Technical Data, publication 5034-TD001
Indicators	1 green module power status indicator 1 green SA power status indicator
Dimensions (HxWxD), approx	131.7 x 20.0 x 75 mm (5.19 x 0.79 x 2.95 in.)
Weight, approx	109 g (3.84 oz.) - 5034-EXP 111 g (3.91 oz.) - 5034-EXPXT
Enclosure type	None (Open-style)
North American temp code	T4
UKEX/ATEX temp code	T4
IECEx temp code	T4

Table 67. General Specifications - 5034-EXP, 5034-EXPXT (continued)

Attribute	5034-EXP, 5034-EXPXT
-----------	----------------------

(1) Use this Conductor Category information for planning conductor routing. See the Industrial Automation Wiring and Grounding Guidelines, publication [1770-4.1](#). Use this Conductor Category information for planning conductor routing as described in the appropriate System Level Installation Manual.

Environmental Specifications and Certifications

The following tables provide the environmental specifications and certifications for the PointMax expansion power.

Table 68. Environmental Specifications - PointMax Expansion Power

Attribute	5034-EXP	5034-EXPXT
Temperature, operating	IEC 60068-2-1 (Test Ae, Operating Cold), IEC 60068-2-2 (Test Be, Operating Dry Heat), IEC 60068-2-14 (Test Nb, Operating Thermal Shock): -25 °C ≤ Ta ≤ +60 °C (-13 °F ≤ Ta ≤ +140 °F) for horizontal orientation -25 °C ≤ Ta ≤ +55 °C (-13 °F ≤ Ta ≤ +131 °F) for other orientations	
Temperature, surrounding air, max	60 °C (140 °F)	
Temperature, nonoperating	IEC 60068-2-1 (Test Ab, Unpackaged Nonoperating Cold), IEC 60068-2-2 (Test Bb, Unpackaged Nonoperating Dry Heat), IEC 60068-2-14 (Test Na, Unpackaged Nonoperating Thermal Shock): -40...+85 °C (-40...+185 °F)	
Relative humidity	IEC 60068-2-30 (Test Db, Unpackaged Damp Heat): 5...95% noncondensing	
Conformal coated	No	Yes
Corrosive Atmosphere ASTM B845-97 Method K Accelerated Test (20-Day Exposure)	Severity Level G3 ⁽¹⁾ per ANSI/ISA 71.04-2013, Airborne Contaminants—Gases	
Corrosive Atmosphere <ul style="list-style-type: none"> • ASTM B845-97 Method K Accelerated Test (30-Day Exposure) • Plus additional Rockwell Automation proprietary accelerated corrosive environment test protocol 	Severity Level GX ⁽²⁾ per ANSI/ISA 71.04-2013, Airborne Contaminants—Gases Severity Level CX per IEC 60721-3-3:2019, Chemically Active Substances	

Table 68. Environmental Specifications - PointMax Expansion Power (continued)

Attribute	5034-EXP	5034-EXPXT
for specific industries with sources of gaseous sulfur compounds.		
Vibration	IEC 60068-2-6 (Test Fc, Operating): 5 g @ 10...500 Hz	
Shock, operating	IEC 60068-2-27 (Test Ea, Unpackaged Shock): 30 g	
Repetitive shock, operating	IEC 60068-2-27: 25 g, 6 ms duration, 1000 shocks in each ± direction in each 3 axis	
Shock, nonoperating	IEC 60068-2-27 (Test Ea, Unpackaged Shock): 50 g	
Emissions	IEC 61000-6-4	
ESD immunity	IEC 61000-4-2: 6 kV contact discharges 8 kV air discharges	
Radiated RF immunity	IEC 61000-4-3: 10V/m with 1 kHz sine wave 80% AM from 80...6000 MHz	
EFT/B immunity	IEC 61000-4-4: ±3 kV @ 5 kHz on power ports	
Surge transient immunity	IEC 61000-4-5: ±1 kV line-line (DM) and ±2 kV line-earth (CM) on power ports	
Conducted RF immunity	IEC 61000-4-6: 10V rms with 1 kHz sine wave 80% AM from 150 kHz...80 MHz	
Voltage dips and variations	IEC 61000-4-29: 10 ms interruption on MP ports	

(1) Up to 86.4 g/(m2.yr), mass loss of copper due to corrosion.

(2) Up to 2100 angstroms of film growth per 30 days of copper and/or silver reactivity.

Table 69. Certifications - PointMax Expansion Power

Certification ⁽¹⁾	5034-EXP, 5034-EXPXT
c-UL-us	UL Listed Industrial Control Equipment, certified for US and Canada. See UL File E322657.

Table 69. Certifications - PointMax Expansion Power (continued)

Certification ⁽¹⁾	5034-EXP, 5034-EXPXT
	UL Listed for Class I, Division 2 Group A,B,C,D Hazardous Locations, certified for U.S. and Canada. See UL File E334470.
UK and CE	UK Statutory Instrument 2016 No. 1091 and European Union 2014/30/EU EMC Directive, compliant with: EN 61326-1; Meas./Control/Lab., Industrial Requirements EN 61000-6-2; Industrial Immunity EN 61000-6-4; Industrial Emissions EN 61131-2; Programmable Controllers (Clause 8, Zone A & B) UK Statutory Instrument 2016 No. 1101 and European Union 2014/35/EU LVD, compliant with: EN 61010-2-201; Control Equipment Safety Requirements UK Statutory Instrument 2012 No. 3032 and European Union 2011/65/EU RoHS, compliant with: EN IEC 63000; Technical documentation
RCM	Australian Radiocommunications Act, compliant with: EN 61000-6-4; Industrial Emissions
Ex	UK Statutory Instrument 2016 No. 1107 and European Union 2014/34/EU ATEX Directive, compliant with: EN IEC 60079-0; General Requirements EN IEC 60079-7; Explosive Atmospheres, Protection "e" II 3 G Ex ec IIC T4 Gc UL 24 ATEX 3272X and UL24UKEX2997X
IECEx	IECEx System, compliant with: IEC 60079-0; General Requirements IEC 60079-7; Explosive Atmospheres, Protection "e" II 3 G Ex ec IIC T4 Gc IECEx UL 24.0066X
KC	Korean Registration of Broadcasting and Communications Equipment, compliant with: Article 58-2 of Radio Waves Act, Clause 4
Morocco	Arrêté ministériel n° 6404-15 du 1 er muharram 1437 Arrêté ministériel n° 6404-15 du 29 ramadan 1436
CCC	CNCA-C23-01 强制性产品认证实施规则 防爆电气 CNCA-C23-01 CCC Implementation Rule Explosion-Proof Electrical Products 2025122309123247

(1) When marked. See the Product Certifications website at rok.auto/certifications for declarations of conformity, certificates, and other certification details.

Power Terminal Module

Module Type	Catalog Number	Description
Power Terminal Module	5034-MBPTM, 5034-MBTMPXT	Power terminal module with base

Environmental specifications and certifications for PointMax power terminal module are provided in [Environmental Specifications and Certifications on page 140](#).

5034-MBPTM and 5034-MBPTMXT Power Terminal Module with Base

Figure 65. 5034-MBPTM and 5034-MBPTMXT Wiring Diagram

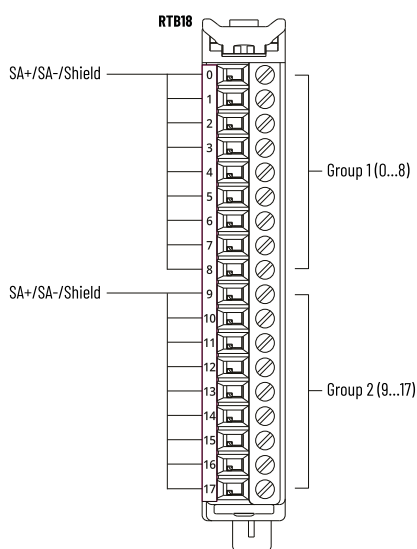

- You can install only one 5034-MBPTM or 5034-MBPTMXT to the right of each I/O module.
 - For 5034-IB16 and 5034-IB16XT only – You can install two consecutive 5034-MBPTM or 5034-MBPTMXT to the right of the module for 3-wire sensor applications.
- All nine terminals in each group are shorted.
- Each group can be connected to either SA+, SA-, or shield terminals from an external source.
- In each group, one terminal serves as the feeder and the other eight terminals function as outputs.

Table 70. General Specifications - 5034-MBPTM, 5034-MBPTMXT

Attribute	5034-MBPTM, 5034-MBPTMXT
SA power voltage, nom	24V DC
SA power voltage range	10...30V DC, SELV
SA power current, per terminal group, max	10 A

Table 70. General Specifications - 5034-MBPTM, 5034-MBPTMXT (continued)

Attribute	5034-MBPTM, 5034-MBPTMXT
Isolation voltage	250V AC basic insulation between terminal group 1 and terminal group 2
RTB key positions (slot)	3, 6, 11
RTB supported	5034-RTB18, 5034-RTB18S
Wiring category ⁽¹⁾	2 - Power ports
Wiring specification	See Wiring Specifications for Removable Terminal Blocks in the PointMax I/O System Specifications Technical Data, publication 5034-TD001
Dimensions (HxWxD), approx	132 x 15 x 75 mm (5.2 x 0.59 x 2.95 in.)
Weight, approx	65.0 g (2.29 oz.) - MBPTM 67.0 g (2.36 oz.) - MBPTMXT
Enclosure type	None (Open-style)
North American temp code	T4
UKEX/ATEX temp code	T4
IECEx temp code	T4

(1) Use this Conductor Category information for planning conductor routing. See the Industrial Automation Wiring and Grounding Guidelines, publication [1770-4.1](#). Use this Conductor Category information for planning conductor routing as described in the appropriate System Level Installation Manual.

Environmental Specifications and Certifications

The following tables provide the environmental specifications and certifications for the PointMax mounting base with potential power terminal module.

Table 71. Environmental Specifications - PointMax Mounting Base with Potential Power Terminal Module

Attribute	5034-MBPTM	5034-MBPTMXT
Temperature, operating	IEC 60068-2-1 (Test Ae, Operating Cold), IEC 60068-2-2 (Test Be, Operating Dry Heat), IEC 60068-2-14 (Test Nb, Operating Thermal Shock): -25 °C ≤ Ta ≤ +60 °C (-13 °F ≤ Ta ≤ +140 °F) for horizontal orientation -25 °C ≤ Ta ≤ +55 °C (-13 °F ≤ Ta ≤ +131 °F) for other orientations	
Temperature, surrounding air, max	60 °C (140 °F)	
Temperature, nonoperating	IEC 60068-2-1 (Test Ab, Unpackaged Nonoperating Cold), IEC 60068-2-2 (Test Bb, Unpackaged Nonoperating Dry Heat),	

Table 71. Environmental Specifications - PointMax Mounting Base with Potential Power Terminal Module (continued)

Attribute	5034-MBPTM	5034-MBPTMXT
	IEC 60068-2-14 (Test Na, Unpackaged Nonoperating Thermal Shock): -40...+85 °C (-40...+185 °F)	
Relative humidity	IEC 60068-2-30 (Test Db, Unpackaged Damp Heat): 5...95% noncondensing	
Conformal coated	No	Yes
Corrosive Atmosphere ASTM B845-97 Method K Accelerated Test (20-Day Exposure)	Severity Level G3 ⁽¹⁾ per ANSI/ISA 71.04-2013, Airborne Contaminants—Gases	—
Corrosive Atmosphere • ASTM B845-97 Method K Accelerated Test (30-Day Exposure) • Plus additional Rockwell Automation proprietary accelerated corrosive environment test protocol for specific industries with sources of gaseous sulfur compounds.	—	Severity Level GX ⁽²⁾ per ANSI/ISA 71.04-2013, Airborne Contaminants—Gases Severity Level CX per IEC 60721-3-3:2019, Chemically Active Substances
Vibration	IEC 60068-2-6 (Test Fc, Operating): 5 g @ 10...500 Hz	
Shock, operating	IEC 60068-2-27 (Test Ea, Unpackaged Shock): 30 g	
Repetitive shock, operating	IEC 60068-2-27: 25 g, 6 ms duration, 1000 shocks in each ± direction in each 3 axis	
Shock, nonoperating	IEC 60068-2-27 (Test Ea, Unpackaged Shock): 50 g	

(1) Up to 86.4 g/(m2.yr), mass loss of copper due to corrosion.

(2) Up to 2100 angstroms of film growth per 30 days of copper and/or silver reactivity.

Table 72. Certifications - PointMax Mounting Base with Potential Power Terminal Module

Certification ⁽¹⁾	5034-MBPTM, 5034-MBPTMXT
c-UL-us	UL Listed Industrial Control Equipment, certified for US and Canada. See UL File E322657.

Table 72. Certifications - PointMax Mounting Base with Potential Power Terminal Module (continued)

Certification ⁽¹⁾	5034-MBPTM, 5034-MBPTMXT
	UL Listed for Class I, Division 2 Group A,B,C,D Hazardous Locations, certified for U.S. and Canada. See UL File E334470.
UK and CE	UK Statutory Instrument 2016 No. 1091 and European Union 2014/30/EU EMC Directive, compliant with: EN 61326-1; Meas./Control/Lab., Industrial Requirements EN 61000-6-2; Industrial Immunity EN 61000-6-4; Industrial Emissions EN 61131-2; Programmable Controllers (Clause 8, Zone A & B) UK Statutory Instrument 2016 No. 1101 and European Union 2014/35/EU LVD, compliant with: EN 61010-2-201; Control Equipment Safety Requirements UK Statutory Instrument 2012 No. 3032 and European Union 2011/65/EU RoHS, compliant with: EN IEC 63000; Technical documentation
RCM	Australian Radiocommunications Act, compliant with: EN 61000-6-4; Industrial Emissions
Ex	UK Statutory Instrument 2016 No. 1107 and European Union 2014/34/EU ATEX Directive, compliant with: EN IEC 60079-0; General Requirements EN IEC 60079-7; Explosive Atmospheres, Protection "e" II 3 G Ex ec IIC T4 Gc UL 24 ATEX 3272X and UL24UKEX2997X
IECEx	IECEx System, compliant with: IEC 60079-0; General Requirements IEC 60079-7; Explosive Atmospheres, Protection "e" II 3 G Ex ec IIC T4 Gc IECEx UL 24.0066X
KC	Korean Registration of Broadcasting and Communications Equipment, compliant with: Article 58-2 of Radio Waves Act, Clause 4
Morocco	Arrêté ministériel n° 6404-15 du 1 er muharram 1437 Arrêté ministériel n° 6404-15 du 29 ramadan 1436
CCC	CNCA-C23-01 强制性产品认证实施规则 防爆电气 CNCA-C23-01 CCC Implementation Rule Explosion-Proof Electrical Products 2025122309123247

(1) When marked. See the Product Certifications website at rok.auto/certifications for declarations of conformity, certificates, and other certification details.

Removable Terminal Blocks

The I/O modules require an MB paired with an RTB to connect field-side wiring.

Type	Catalog Number	Description
Removable Terminal Block	5034-RTB2, 5034-RTB2S	Removable terminal block 2-terminals (screw-type and push-in spring-type)
	5034-RTB6, 5034-RTB6S	Removable terminal block 6-terminals (screw-type and push-in spring-type)
	5034-RTB18, 5034-RTB18S	Removable terminal block 18-terminals (screw-type and push-in spring-type)
	5034-RTB24S	Removable terminal block 24-terminals (push-in spring-type)
	5034-RTBT, 5034-RTBTS	Removable terminal block with CJC 18-terminals (screw-type and push-in spring type)

Environmental specifications and certifications for PointMax removable terminal blocks are provided in [Environmental Specifications on page 149](#).

5034-RTB2 and 5034-RTB2S Removable Terminal Blocks

Use these RTBs with the 5034-MBSA and 5034-MBSAXT mounting bases. These catalogs are not available for purchase individually. They can only be ordered in a pack of 5 (5034-RTB2-QTY5 or RTB2S-QTY5).

Figure 66. 5034-RTB2 and 5034-RTB2S Diagram

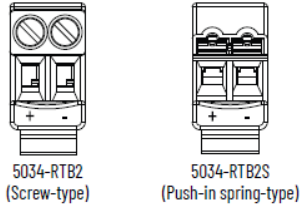

Table 73. General Specifications - 5034-RTB2, 5034-RTB2S

Attribute	5034-RTB2, 5034-RTB2S
Voltage rating	240V AC
Current rating per position at 60 °C (140 °F)	10 A
Wiring specification	See Wiring Specifications for Removable Terminal Blocks in the PointMax I/O System Specifications Technical Data, publication 5034-TD001
Dimensions (HxWxD), approx	18.6 x 9.3 x 21.15 mm (0.73 x 0.37 x 0.83 in.)
Weight, approx	3.5 g (0.12 oz.) - 5034-RTB2 2.1 g (0.07 oz.) - 5034-RTB2S
Enclosure type	None (Open-style)
North American temp code	T4
UKEX/ATEX temp code	T4
IECEx temp code	T4

5034-RTB6 and 5034-RTB6S Removable Terminal Blocks

Use these RTBs with the 5034-AENTR and 5034-AENTRXT EtherNet/IP adapter or the 5034-EXP and 5034-EXPXT expansion power. These catalogs are not available for purchase individually. They can only be ordered in a pack of 5 (5034-AENRTB-QTY5 or 5034-AENRTBS-QTY5).

Figure 67. 5034-RTB6 and 5034-RTB6S Diagram

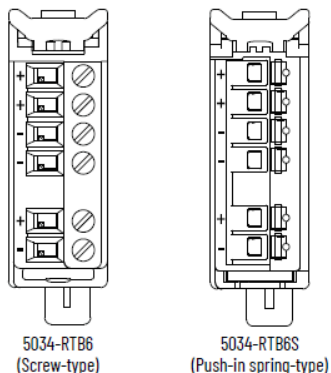

Table 74. General Specifications - 5034-RTB6, 5034-RTB6S

Attribute	5034-RTB6, 5034-RTB6S
Voltage rating	240V AC
Current, max	10 A
Current rating per position at 60 °C (140 °F)	Positions 0...3: 2 A Positions 4 and 5: 10 A
Wiring specification	See Wiring Specifications for Removable Terminal Blocks in the PointMax I/O System Specifications Technical Data, publication 5034-TD001
Dimensions (HxWxD), approx	46.6 x 14.7 x 31.3 mm (1.83 x 0.58 x 1.23 in.)
Weight, approx	11.2 g (0.39 oz.) - 5034-RTB6 7.9 g (0.28 oz.) - 5034-RTB6S
Enclosure type	None (Open-style)
North American temp code	T4
UKEX/ATEX temp code	T4
IECEx temp code	T4

5034-RTB18 and 5034-RTB18S Removable Terminal Blocks

Figure 68. 5034-RTB18 and 5034-RTB18S Diagram

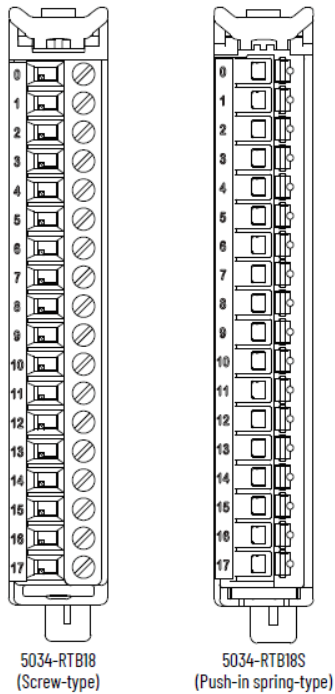
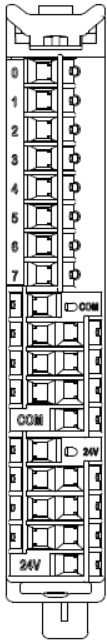

Table 75. General Specifications - 5034-RTB18, 5034-RTB18S

Attribute	5034-RTB18, 5034-RTB18S
Voltage rating	240V AC
Current, max	10 A
Wiring specification	See Wiring Specifications for Removable Terminal Blocks in the PointMax I/O System Specifications Technical Data, publication 5034-TD001
Dimensions (HxWxD), approx	93.8 x 14.7 x 31.3 mm (3.69 x 0.58 x 1.23 in.)
Weight, approx	28 g (0.99 oz.) - 5034-RTB18 18 g (0.63 oz.) - 5034-RTB18S
Enclosure type	None (Open-style)
North American temp code	T4
UKEX/ATEX temp code	T4
IECEx temp code	T4

5034-RTB24S Removable Terminal Blocks

Figure 69. 5034-RTB24S Diagram



5034-RTB24S
(Push-in spring-type)

Table 76. General Specifications - 5034-RTB24S

Attribute	5034-RTB24S
Voltage rating	240V AC
Current, max	10 A
Wiring specification	See Wiring Specifications for Removable Terminal Blocks in the PointMax I/O System Specifications Technical Data, publication 5034-TD001
Dimensions (HxWxD), approx	93.8 x 14.7 x 31.3 mm (3.69 x 0.58 x 1.23 in.)
Weight, approx	20 g (0.70 oz.)
Enclosure type	None (Open-style)
North American temp code	T4
UKEX/ATEX temp code	T4
IECEx temp code	T4

5034-RTBT and 5034-RTBTS Removable Terminal Blocks with CJC

Use these RTBs with the 5034-IRT4I and 5034-IRT4IXT analog 4 input isolated RTD/TC modules to help achieve better accuracy.

Figure 70. 5034-RTBT and 5034-RTBTS Diagram

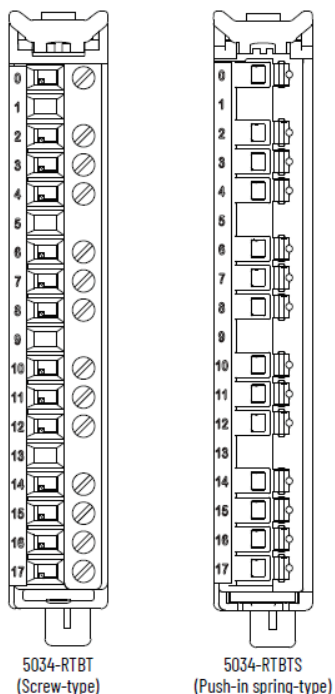

Table 77. General Specifications - 5034-RTBT, 5034-RTBTS

Attribute	5034-RTBT, 5034-RTBTS
Voltage rating	240V AC
Current, max	10 A
Wiring specification	See Wiring Specifications for Removable Terminal Blocks in the PointMax I/O System Specifications Technical Data, publication 5034-TD001
Dimensions (HxWxD), approx	93.8 x 14.7 x 31.3 mm (3.69 x 0.58 x 1.23 in.)
Weight, approx	27.0 g (0.95 oz.) - 5034-RTBT 17.0 g (0.60 oz.) - 5034-RTBTS
Enclosure type	None (Open-style)
North American temp code	T4
UKEX/ATEX temp code	T4
IECEx temp code	T4

Environmental Specifications

The following table provides the environmental specifications for the PointMax removable terminal blocks.

Table 78. Environmental Specifications - PointMax Removable Terminal Blocks

Attribute	5034-RTB2, 5034-RTB2S, 5034-RTB6, 5034-RTB6S, 5034-RTB18, 5034-RTB18S, 5034-RTB24S, 5034-RTBT, 5034-RTBTS
Temperature, operating	IEC 60068-2-1 (Test Ae, Operating Cold), IEC 60068-2-2 (Test Be, Operating Dry Heat), IEC 60068-2-14 (Test Nb, Operating Thermal Shock): -25 °C ≤ Ta ≤ +60 °C (-13 °F ≤ Ta ≤ +140 °F) for horizontal orientation -25 °C ≤ Ta ≤ +55 °C (-13 °F ≤ Ta ≤ +131 °F) for other orientations
Temperature, surrounding air, max	60 °C (140 °F)
Temperature, nonoperating	IEC 60068-2-1 (Test Ab, Unpackaged Nonoperating Cold), IEC 60068-2-2 (Test Bb, Unpackaged Nonoperating Dry Heat), IEC 60068-2-14 (Test Na, Unpackaged Nonoperating Thermal Shock): -40...+85 °C (-40...+185 °F)
Relative humidity	IEC 60068-2-30 (Test Db, Unpackaged Damp Heat): 5...95% noncondensing
Vibration	IEC 60068-2-6 (Test Fc, Operating): 5 g @ 10...500 Hz
Shock, operating	IEC 60068-2-27 (Test Ea, Unpackaged Shock): 30 g
Repetitive shock, operating	IEC 60068-2-27: 25 g, 6 ms duration, 1000 shocks in each ± direction in each 3 axis
Shock, nonoperating	IEC 60068-2-27 (Test Ea, Unpackaged Shock): 50 g
Emissions	IEC 61000-6-4
ESD immunity	IEC 61000-4-2: 6 kV contact discharges 8 kV air discharges
Radiated RF immunity	IEC 61000-4-3: 10V/m with 1 kHz sine wave 80% AM from 80...6000 MHz
EFT/B immunity	IEC 61000-4-4: ±3 kV @ 5 kHz on signal ports

Table 78. Environmental Specifications - PointMax Removable Terminal Blocks (continued)

Attribute	5034-RTB2, 5034-RTB2S, 5034-RTB6, 5034-RTB6S, 5034-RTB18, 5034-RTB18S, 5034-RTB24S, 5034-RTBT, 5034-RTBTS
Surge transient immunity	IEC 61000-4-5: ±2 kV line-earth (CM) on signal ports
Conducted RF immunity	IEC 61000-4-6: 10V rms with 1 kHz sine wave 80% AM from 150 kHz...80 MHz

Wiring Specifications for Removable Terminal Blocks

These wiring specifications apply to all PointMax removable terminal blocks – 5034-RTB2, 5034-RTB2S, 5034-RTB6, 5034-RTB6S, 5034-RTB18, 5034-RTB18S, 5034-RTB24S, 5034-RTBT, 5034-RTBTS.

Wire conductor and insulation rating must support a minimum temperature rating of 105 °C (221 °F). The tightening torque value for screw-type RTBs is 0.22...0.25 N•m (1.95...2.21 lb•in.).

Table 79. Wiring Specification – 1-wire

Wire Type	Wire Range
Stranded and solid copper	0.34...1.5 mm ² (22...16 AWG)

Screw RTB tightening torque: 0.22...0.25 N•m (1.95...2.21 lb•in)
 Recommended strip length: 10 ± 0.4 mm (± 0.016 in.)

Table 80. Wiring Specification – 1-wire with Plastic Sleeve Ferrule

Wire Type	Wire Range	Ferrule Length	Example
Stranded copper	0.5...1.5 mm ² (20...16 AWG)	10 mm (0.39 in.) ⁽¹⁾	
Stranded copper	0.34 mm ² (22 AWG)	8 mm (0.31 in.) ⁽²⁾	

Recommended crimper: Phoenix Contact Crimpfox 6, Weidmuller PZ 6 Roto, and TE 539660-1

Recommended strip length: See ferrule manufacturer’s recommendation.

(1) DIN standard: 46228-4

(2) Non-DIN standard application

Table 81. Wiring Specification – 1-wire with Non-plastic Sleeve Ferrule

Wire Type	Wire Range	Ferrule Length	Example
Stranded copper	0.5...1.5 mm ² (20...16 AWG)	10 mm (0.39 in.) ⁽¹⁾	
Stranded copper	0.34 mm ² (22 AWG)	7 mm (0.28 in.) ⁽²⁾	

Recommended crimper: Phoenix Contact Crimpfox 6, Weidmuller PZ 6 Roto, and TE 539660-1

Recommended strip length: See ferrule manufacturer’s recommendation.

(1) DIN standard: 46228-4

(2) Non-DIN standard application

Accessories

Catalog Number	Description
5034-AENRTB-QTY5 5034-AENRTBS-QTY5	6-pin RTB (Qty. 5) for EtherNet/IP adapter and expansion power
5034-RTB2-QTY5 5034-RTB2S-QTY5	2-pin RTB (Qty. 5) for mounting base 15 mm (0.59 in.) with SA power
5034-ECR-QTY5	I/O system end cap (Qty. 5)
5034-CM18-IB16-QTY5 5034-CM18-OB16-QTY5 5034-CM18-IB8-QTY5 5034-CM18-IB8S-QTY5 5034-CM18-OB8-QTY5 5034-CM18-OB4-QTY5 5034-CM18-UB8-QTY5 5034-CM18-IF4-QTY5 5034-CM18-IF4IH-QTY5 5034-CM18-OF4-QTY5 5034-CM18-OF4IH-QTY5 5034-CM18-IF8C-QTY5 5034-CM18-IF8V-QTY5 5034-CM18-IRT4I-QTY5 5034-CM18-OW4I-QTY5 5034-CM18-IOL4-QTY5 5034-CM18-SERIAL-QTY5 5034-CM18-ENC-QTY5 5034-CM18-MBPTM-QTY5 5034-CM24-IF8-QTY5 5034-CM24-IB8-QTY5 5034-CM24-UB8-QTY5	Color markers for RTB (Qty. 5)
5034-KEY-QTY5	RTB insertable key (Qty. 5)
5034-SHIELD-QTY5	1-wire shield clamp (Qty. 5)
5034-WIREHLD-QTY5	Wire or cable holder (Qty. 5)
5034-N	Filler module

5034-AENRTB-QTY5 and 5034-AENRTBS-QTY5 RTB for EtherNet/IP Adapter and Expansion Power

Use these catalog numbers to order additional screw-type (5034-RTB6) or push-in spring-type (5034-RTB6S) RTBs for use with the 5034-AENTR and 5034-AENTRXT EtherNet/IP adapters, and 5034-EXP and 5034-EXPXT expansion power. Each RTB is available in a pack of five units.

For specifications, see [5034-RTB6 and 5034-RTB6S Removable Terminal Blocks on page 145](#).

5034-RTB2-QTY5 and 5034-RTB2S-QTY5 RTB for MBSA Mounting Base

Use these catalog numbers to order additional screw-type (5034-RTB2) or push-in spring-type (5034-RTB2S) RTBs for use with the 5034-MBSA and 5034-MBSAXT mounting bases. Each RTB is available in a pack of five units.

For specifications, see [5034-RTB2 and 5034-RTB2S Removable Terminal Blocks on page 144](#).

5034-ECR-QTY5 End Cap

Use this catalog number to order additional end caps. Install an end cap to cover the exposed interconnections on the adapter or the last mounting base on the DIN rail. The end cap is available in a pack of five units.

Figure 71. 5034-ECR Diagram

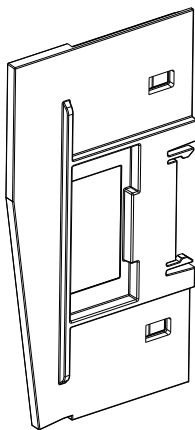

5034-CM18 and 5034-CM24 Color Markers for Removable Terminal Blocks

Use color markers to help you identify the type of I/O module that an RTB is used with. Each color marker is available in a pack of five units.

Figure 72. 5034-CM18 and 5034-CM24 Diagram

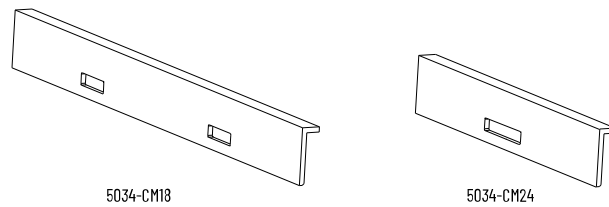

Table 82. Color Markers for RTBs

Catalog Number	Use with RTB	Description
5034-CM18-IB16-QTY5	5034-RTB18, 5034-RTB18S	Color marker for 5034-IB16 and 5034-IB16XT (Qty. 5)
5034-CM18-OB16-QTY5	5034-RTB18, 5034-RTB18S	Color marker for 5034-OB16 and 5034-OB16XT (Qty. 5)
5034-CM18-IB8-QTY5	5034-RTB18, 5034-RTB18S	Color marker for 5034-IB8 and 5034-IB8XT (Qty. 5)
5034-CM18-IB8S-QTY5	5034-RTB18, 5034-RTB18S	Color marker for 5034-IB8S and 5034-IB8SXT (Qty. 5)
5034-CM18-OB8-QTY5	5034-RTB18, 5034-RTB18S	Color marker for 5034-OB8, 5034-OB8XT, 5034-OB8S, and 5034-OB8SXT (Qty. 5)
5034-CM18-OB4-QTY5	5034-RTB18, 5034-RTB18S	Color marker for 5034-OB4 and 5034-OB4XT (Qty. 5)
5034-CM18-UB8-QTY5	5034-RTB18, 5034-RTB18S	Color marker for 5034-UB8, 5034-UB8XT, 5034-UB8F, and 5034-UB8FXT (Qty. 5)
5034-CM18-IF4-QTY5	5034-RTB18, 5034-RTB18S	Color marker for 5034-IF4IH and 5034-IF4IHXT (Qty. 5)
5034-CM18-IF4IH-QTY5	5034-RTB18, 5034-RTB18S	Color marker for 5034-IF4 and 5034-IF4XT (Qty. 5)
5034-CM18-OF4-QTY5	5034-RTB18, 5034-RTB18S	Color marker for 5034-OF4 and 5034-OF4XT (Qty. 5)
5034-CM18-OF4IH-QTY5	5034-RTB18, 5034-RTB18S	Color marker for 5034-OF4IH and 5034-OF4IHXT (Qty. 5)
5034-CM18-IF8C-QTY5	5034-RTB18, 5034-RTB18S	Color marker for 5034-IF8C and 5034-IF8CXT (Qty. 5)
5034-CM18-IF8V-QTY5	5034-RTB18, 5034-RTB18S	Color marker for 5034-IF8V and 5034-IF8VXT (Qty. 5)
5034-CM18-IRT4I-QTY5	5034-RTB18, 5034-RTB18S 5034-RTBT, 5034-RTBTS	Color marker for 5034-IRT4I and 5034-IRT4IXT (Qty. 5)
5034-CM18-OW4I-QTY5	5034-RTB18, 5034-RTB18S	Color marker for 5034-OW4I and 5034-OW4IXT (Qty. 5)
5034-CM18-IOL4-QTY5	5034-RTB18, 5034-RTB18S	Color marker for 5034-IOL4 and 5034-IOL4XT (Qty. 5)
5034-CM18-SERIAL-QTY5	5034-RTB18, 5034-RTB18S	Color marker for 5034-SERIAL and 5034-SERIALXT (Qty. 5)
5034-CM18-ENC-QTY5	5034-RTB18, 5034-RTB18S	Color marker for 5034-ENC and 5034-ENCXT (Qty. 5)

Table 82. Color Markers for RTBs (continued)

Catalog Number	Use with RTB	Description
5034-CM18-MBPTM-QTY5	5034-RTB18, 5034-RTB18S	Color marker for 5034-MBPTM and 5034-MBPTMXT (Qty. 5)
5034-CM24-IF8-QTY5	5034-RTB24S	Color marker for 5034-IF8C, 5034-IF8CXT, 5034-IF8V, and 5034-IF8VXT (Qty. 5)
5034-CM24-IB8-QTY5	5034-RTB24S	Color marker for 5034-IB8 and 5034-IB8XT (Qty. 5)
5034-CM24-UB8-QTY5	5034-RTB24S	Color marker for 5034-UB8, 5034-UB8XT, 5034-UB8F, and 5034-UB8FXT (Qty. 5)

5034-KEY-QTY5 Insertable Key for Removable Terminal Blocks

Use an insertable key to match an RTB to a type of I/O module. The insertable key is available in a pack of five units.

For the RTB key positions of each I/O module, see the PointMax I/O System Installation Instructions, publication [5034-IN001](#).

Figure 73. 5034-KEY Diagram

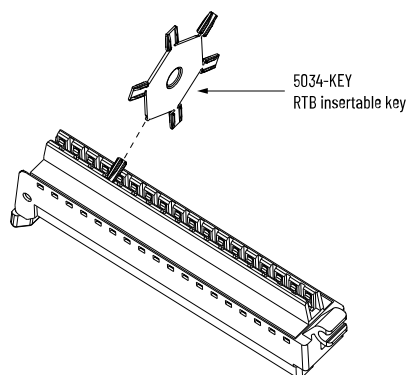

5034-SHIELD-QTY5 Shield Clamp

The shield clamp is available in a pack of five units.

Figure 74. 5034-SHIELD Diagram

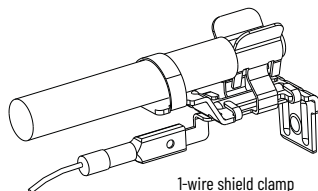

5034-WIREHLD-QTY5 Wire Holder

The wire holder is available in a pack of five units.

Figure 75. 5034-WIREHLD Diagram

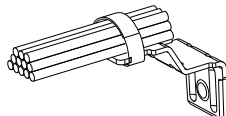

5034-N Filler Module

Use the filler module to occupy an empty slot in an I/O chassis, typically where an MB is installed but no I/O module is present. The filler module can be used to hold an RTB in place. The filler module contains no electronics.

Figure 76. 5034-N Diagram

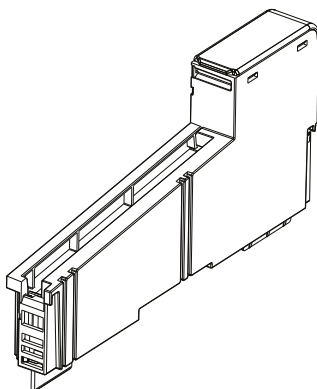

Additional Resources

These documents contain additional information concerning related products from Rockwell Automation. You can view or download publications at rok.auto/literature.

Table 83. Additional Resources

Resources	Description
PointMax I/O System Specifications Technical Data, publication 5034-TD001	Provides PointMax I/O system specifications.
PointMax I/O System Installation Instructions, publication 5034-IN001	Provides instructions on installing a complete PointMax I/O system.
PointMax EtherNet/IP Adapter User Manual, publication 5034-UM001	Provides information on how to configure and operate PointMax EtherNet/IP adapters.
PointMax Digital I/O Modules User Manual, publication 5034-UM002	Provides information on how to configure and operate PointMax digital I/O modules.
PointMax Analog I/O Modules User Manual, publication 5034-UM003	Provides information on how to configure and operate PointMax analog I/O modules.
PointMax 4-Channel IO-Link Master Module User Manual, publication 5034-UM004	Provides information on how to configure and operate the PointMax IO-Link master module.
PointMax Serial Module User Manual, publication 5034-UM005	Provides information on how to configure and operate the PointMax serial module.
PointMax High-speed Counter/SSI Encoder Module User Manual, publication 5034-UM006	Provides information on how to configure and operate the PointMax high-speed counter/SSI encoder module.
PointMax Analog HART I/O Modules User Manual, publication 5034-UM007	Provides information on how to configure and operate the PointMax analog HART I/O modules.
EtherNet/IP Network Devices User Manual, publication ENET-UM006	Describes how to configure and use EtherNet/IP devices to communicate on the EtherNet/IP network.
Ethernet Reference Manual, publication ENET-RM002	Describes basic Ethernet concepts, infrastructure components, and infrastructure features.
System Security Design Guidelines Reference Manual, publication SECURE-RM001	Provides guidance on how to conduct security assessments, implement Rockwell Automation® products in a secure system, harden the control system, manage user access, and dispose of equipment.
Safety Guidelines for the Application, Installation, and Maintenance of Solid-state Control, publication SGI-1.1	Designed to harmonize with NEMA Standards Publication No. ICS 1.1-1987 and provides general guidelines for the application, installation, and maintenance of solid-state control in the form of individual devices or packaged assemblies incorporating solid-state components.
Industrial Automation Wiring and Grounding Guidelines, publication 1770-4.1	Provides general guidelines for installing a Rockwell Automation industrial system.
Product Selection and Configuration tools website, rok.auto/systemtools	Helps configure complete, valid catalog numbers and build complete quotes based on detailed product information.

Table 83. Additional Resources (continued)

Resources	Description
Product Certifications website, rok.auto/certifications	Provides declarations of conformity, certificates, and other certification details.

Rockwell Automation Support

Use these resources to access support information.

Technical Support Center	Find help with how-to videos, FAQs, chat, user forums, and product notification updates.	rok.auto/support
Local Technical Support Phone Numbers	Locate the telephone number for your country.	rok.auto/phonesupport
Technical Documentation Center	Quickly access and download technical specifications, installation instructions, and user manuals.	rok.auto/techdocs
Literature Library	Find installation instructions, manuals, brochures, and technical data publications.	rok.auto/literature
Product Compatibility and Download Center (PCDC)	Get help determining how products interact, check features and capabilities, and find associated firmware.	rok.auto/pcdc

Documentation Feedback

Your comments help us serve your documentation needs better. If you have any suggestions on how to improve our content, complete the form at rok.auto/docfeedback.

Waste Electrical and Electronic Equipment (WEEE)



At the end of life, this equipment should be collected separately from any unsorted municipal waste.

Rockwell Automation maintains current product environmental information on its website at rok.auto/pec.





Allen-Bradley, expanding human possibility, FactoryTalk, GuardLogix, Logix 5000, PointMax, Rockwell Automation, Studio 5000 Logix Designer, and TechConnect are trademarks of Rockwell Automation, Inc.

CIP, CIP Sync, ControlNet, DeviceNet, and EtherNet/IP are trademarks of ODVA, Inc.

Trademarks not belonging to Rockwell Automation are property of their respective companies.

Rockwell Automation NV Commercial Registration Number 0424.293.935

Rockwell Otomasyon Ticaret A.Ş. Kar Plaza İş Merkezi E Blok Kat:6 34752 İçerenköy, İstanbul, Tel: +90 (216) 5698400 EEE Yönetmeliğine Uygundur

Connect with us.    

rockwellautomation.com — expanding **human possibility**[®]

AMERICAS: Rockwell Automation, 1201 South Second Street, Milwaukee, WI 53204-2496 USA, Tel: (1) 414.382.2000

EUROPE/MIDDLE EAST/AFRICA: Rockwell Automation NV, Pegasus Park, De Kleetlaan 12a, 1831 Diegem, Belgium, Tel: (32) 2663 0600

ASIA PACIFIC: Rockwell Automation SEA Pte Ltd, 2 Corporation Road, #04-05, Main Lobby, Corporation Place, Singapore 618494, Tel: (65) 6510 6608

UNITED KINGDOM: Rockwell Automation Ltd., Pitfield, Kiln Farm, Milton Keynes, MK11 3DR, United Kingdom, Tel: (44)(1908) 838-800