



Control Circuit Transformers

Bulletin Numbers 1497, 1497A, 1497B, 1497D

Topic	Page
Summary of Changes	2
Control Circuit Transformers Product Overview	3
Bulletin 1497 – Global Control Circuit Transformers	4
Bulletin 1497A – Machine Tool Transformers	13
Bulletin 1497B – Control Power Transformers	22
Bulletin 1497D – 1-Phase General Purpose Transformers	30
General Purpose Transformers Accessories	46
Additional Resources	49

Summary of Changes

This publication contains new and updated information as indicated in the following table.

Topic	Page
Updated global control circuit transformers specifications per Ecodesign Regulation (EU) 548/2014 and its amendments	10
Part numbers 1491-R173, 1491-R175 have been discontinued and are no longer available for sale.	46
Updated voltages for M18 Secondary from 115/94V (50/60 Hz) to 120/24V (50/60 Hz)	14

Control Circuit Transformers Product Overview

Bulletin	1497	1497A	1497B	1497D
Type	Control Circuit Transformer	Machine Tool Transformer	Control Power Transformer	General Purpose Transformer
Features	<ul style="list-style-type: none"> • Single, dual, and multi-tap primary voltages • Single phase • EN 60-529 finger-safe protection • RoHS compliant • 50/60 Hz, 50 Hz, or 60 Hz • Optional Fusing 	<ul style="list-style-type: none"> • Dual/Multi-tap • RoHS compliant • Single phase • 50/60 Hz • Optional Fusing 	<ul style="list-style-type: none"> • Dual/Multi-tap • RoHS compliant • Single phase • 60 Hz only • Optional Fusing 	<ul style="list-style-type: none"> • Indoor/outdoor non-ventilated enclosure • Single phase • Exceeds requirements of the Uniform Building Code (UBC) and California Code Title 24 • Copper windings provided for all transformers rated 2 kVA and below • Aluminum windings provided for all transformers rated 2 kVA and above • NEMA Type 3R rated enclosures • 50/60 HZ or 60 Hz
Output Power	63...2000VA	50...3000VA	50...3000VA	0.05...25 kVA
Input Voltage/ Primary Voltage	208...600V 220...550 (50 Hz)	208...575V (50/60 Hz)	120...600V	208...600V
Output Voltage/ Secondary Voltage	24...120V 24...230V (50 Hz)	24...120V (50/60 Hz)	24...240V	120...240V
Insulation	63...2000VA – Class 130 °C (55...80 °C temp. rise)	50...150VA – Class 105 °C (55 °C temp. rise) 200...1500VA – Class 130 °C (80 °C temp. rise) 2000...3000VA – Class 180 °C (100 °C temp. rise)		Class 180 °C (115 °C temp. rise)
Certifications	cULus, CE	cULus	cULus	UL, CSA
Standards	CSA C22.2 No. 66.1, CSA C22.2 No. 66.2, EN 61558, UL 5085-1, 5085-2	CSA C22.2 No. 66.1, UL 5085-2	CSA C22.2 No. 66.1, UL 5085-2	CSA C22.2 No. 47 - M90, UL 1561
Product Selection	Page 4	Page 7	Page 22	Page 30

Bulletin 1497 – Global Control Circuit Transformers

Bulletin 1497 Global Control Circuit Transformers are designed to reduce supply voltages to control circuits. The complete line of transformers is available with optional factory-installed or panel-mount primary and secondary fuse block. A dual primary and secondary fuse block is pre-wired and mounted on top of the transformer up to 500VA.

- 63...2000VA
- Single, dual, and multi-tap primary voltages
- Single phase
- EN 60-529 finger-safe protection
- RoHS compliant



Cat. No. 1497-B-HXJX-3-N
Control Circuit Transformer, 3-pole
Fuse Block with Optional
Cat. No. 1491-R150 Fuse Cover



Cat. No. 1497-C-BASX-0-N
Control Circuit Transformer,
Non-Fused

Topic	Page
Product Selection	7
Fuse Sizing Charts	8
Approximate Dimensions	11
Accessories	46

Standards Compliance

- UL 5085-1, UL 5085-2
- EN61558
- CSA C22.2 No. 66.1, CSA C22.2 No. 66.2

Certifications

- cULus Listed (File No. E52057; Guide No. XPTQ, XPTQ7)
- CE

Catalog Number Explanation

Bulletin 1497 Multi-Tap Transformers

1497 - **A** **M1** **3** **N**
 a b c d

a		b			c		d	
VA Rating		Primary and Secondary Voltage			Fuse Block Options		Factory Installed Options	
Code	Description [VA]	Code	Primary	Secondary	Code	Block Options	Code	Description
A	63	M1	240V, 208V	120V (60 Hz)	0	0 Primary, 0 Secondary	N	No Fusing, No Cover
B	80	M2	240V, 208V	24V (60 Hz)	1	0 Primary, 1 Secondary		
C	130	M3	240V, 208V	24V, 120V (60 Hz)	2	2 Primary, 0 Secondary		
D	200	M4	415V, 400V, 380V	115X230V (50 Hz)	3	2 Primary, 1 Secondary		
E	250	M5	415V, 400V, 380V	24V (50 Hz)				
F	350							
G	500							
H	750							
J	800							
K	1000							
L	1600							
M	2000							

Bulletin 1497 Transformers

1497 - **A** **BADX** **3** **N**
 a b c d

a		b			c		d	
VA Rating		Primary and Secondary Voltage			Fuse Block Options		Factory Installed Options	
Code	Description [VA]	Code	Primary	Secondary	Code	Block Options	Code ⁽¹⁾	Description
A	63	HX	208V (60 Hz)	—	0	0 Primary, 0 Secondary	N	No Fusing, No Cover
B	80	AX	240V (60 Hz), 220V (50Hz)	—	1	0 Primary, 1 Secondary		
C	130	BA ⁽²⁾	240X480V (60 Hz), 220X440V (50 Hz)	—	2	2 Primary, 0 Secondary		
D	200	CX ⁽³⁾	600V (60 Hz), 550V (50 Hz)	—	3	2 Primary, 1 Secondary		
E	250	DX ⁽⁴⁾	—	120V (60 Hz)				
F	350	JX	—	24V (60 Hz)				
G	500	SX	—	120V (60 Hz), 110V (50Hz)				
H	750	JK	—	24V (50 Hz), 26V (60 Hz)				
J	800							
K	1000							
L	1600							
M	2000							

(1) VA rating codes H...M are only available with no fuse block option (0).

(2) When the primary voltage code BA is selected and a 120V AC secondary is desired, the secondary voltage code SX should be selected.

(3) VA rating codes G, H, or J with primary voltage over 500V have only cULus approval.

(4) Not available for use with primary voltage code BA.

Selecting a Control Circuit Transformer

For proper transformer selection, three characteristics of the load circuit must be determined in addition to the minimum voltage required to operate the circuit. These are total steady-state (sealed) VA, total inrush VA, and inrush load power factor.

- Total steady-state (sealed) VA is the volt-amperes that the transformer must deliver to the load circuit for an extended period of time – the amount of current required to hold the contact in the circuit.
- Total inrush VA is the volt amperes that the transformer must deliver upon initial energization of the control circuit. Energization of electromagnetic devices takes 30...50 milliseconds. During this inrush period, the electromagnetic control devices draw many times normal current – 3...10 times normal is typical.
- Inrush load power factor is difficult to determine without detailed vector analysis of all the load components. Such an analysis is generally not feasible. Therefore, a safe assumption is 40% power factor.

Selection Process

1. Determine the total inrush VA of the control circuits from [Table 2](#). Do not neglect the current requirements of indicating lights and other devices that do not have an inrush VA but are re-energized at the same time as the other components in the circuit. Their total VA should be added to the total inrush VA.
2. See [Table 1](#). If the supply circuit voltage (Step 1) is reasonably stable and fluctuates not more than $\pm 5\%$, refer to the 90% secondary voltage column. If it fluctuates as much as $\pm 10\%$, refer to the 85% secondary voltage column. Go down the column selected until at the inrush VA closest to, but not less than, the inrush VA of the control circuit.
3. Read to the far left side of the chart. The transformer's continuous nominal VA rating is now selected. The secondary voltage that will be delivered under inrush conditions will be either 85%, 90%, or 95% of the rated secondary voltage, depending on the column selected from [Table 1](#). The total sealed VA of the control circuit must not exceed the nominal VA rating of the transformer selected from [Table 2](#).
4. Refer to the specification tables on [page 7](#) and [page 8](#) to select a transformer according to the required continuous nominal VA, and primary and secondary voltage combinations.

Table 1 - Regulation Data - Inrush VA

Nominal VA Rating	Inrush VA at 40% Power Factor			Power Factor Adjustments	
	85%	90%	95%	Power Factor (pf)	Divide By
63	347	289	216	100%	0.64
80	338	290	229	90%	0.67
130	907	745	541	80%	0.71
200	1267	1039	754	70%	0.78
250	1394	1116	781	60%	0.82
350	2870	2298	1584	50%	0.91
500	3786	3013	2065	40%	1.00
750	7360	5763	3786	30%	1.11
800	7360	5763	3786	20%	1.29
1000	8837	6785	4329	10%	1.50
1600	14921	11328	7070	–	–
2000	20500	14850	9100	–	–

Table 2 - Typical Magnetic Motor Starter and Contactor Data 60 Hz, 120 Volt, 3-Pole

Contactor	NEMA Size						
	0	1	2	3	4	5	
Bulletin 500	192	192	240	660	1225	1490	VA Inrush
	29	29	29	45	69	96	VA Sealed

Product Selection

Continuous VA	Cat. Nos.					
	Primary 208V (60 Hz)		Primary 240V (60 Hz)/220V (50 Hz)		Primary 240X480V (60 Hz) or 220X440V (50 Hz)	
Secondary 24V (60 Hz)	Secondary 120V (60 Hz)	Secondary 26V (60 Hz)/24V (50 Hz)	Secondary 120V (60 Hz)/110V (50 Hz)	Secondary 26V (60 Hz) or 24V (50 Hz)	Secondary 120V (60 Hz) or 110V (50 Hz)	
63	1497-A-HXJX-0-N	1497-A-HXDX-0-N	1497-A-AXJK-0-N	1497-A-AXSX-0-N	1497-A-BAJK-0-N	1497-A-BASX-0-N
80	1497-B-HXJX-0-N	1497-B-HXDX-0-N	1497-B-AXJK-0-N	1497-B-AXSX-0-N	1497-B-BAJK-0-N	1497-B-BASX-0-N
130	1497-C-HXJX-0-N	1497-C-HXDX-0-N	1497-C-AXJK-0-N	1497-C-AXSX-0-N	1497-C-BAJK-0-N	1497-C-BASX-0-N
200	1497-D-HXJX-0-N	1497-D-HXDX-0-N	1497-D-AXJK-0-N	1497-D-AXSX-0-N	1497-D-BAJK-0-N	1497-D-BASX-0-N
250	1497-E-HXJX-0-N	1497-E-HXDX-0-N	1497-E-AXJK-0-N	1497-E-AXSX-0-N	1497-E-BAJK-0-N	1497-E-BASX-0-N
350	1497-F-HXJX-0-N	1497-F-HXDX-0-N	1497-F-AXJK-0-N	1497-F-AXSX-0-N	1497-F-BAJK-0-N	1497-F-BASX-0-N
500	1497-G-HXJX-0-N	1497-G-HXDX-0-N	1497-G-AXJK-0-N	1497-G-AXSX-0-N	1497-G-BAJK-0-N	1497-G-BASX-0-N
750	1497-H-HXJX-0-N	1497-H-HXDX-0-N	1497-H-AXJK-0-N	1497-H-AXSX-0-N	1497-H-BAJK-0-N	1497-H-BASX-0-N
800	1497-J-HXJX-0-N	1497-J-HXDX-0-N	1497-J-AXJK-0-N	1497-J-AXSX-0-N	1497-J-BAJK-0-N	1497-J-BASX-0-N
1000	1497-K-HXJX-0-N	1497-K-HXDX-0-N	1497-K-AXJK-0-N	1497-K-AXSX-0-N	1497-K-BAJK-0-N	1497-K-BASX-0-N
1600	—	1497-L-HXDX-0-N	—	1497-L-AXSX-0-N	—	1497-L-BASX-0-N
2000	—	1497-M-HXDX-0-N	—	1497-M-AXSX-0-N	—	1497-M-BASX-0-N

With 2-Pole Primary and 1-Pole Secondary Top-Mounted Fuse Block⁽¹⁾ § – Fuses Not Included

63	1497-A-HXJX-3-N	1497-A-HXDX-3-N	1497-A-AXJK-3-N	1497-A-AXSX-3-N	1497-A-BAJK-3-N	1497-A-BASX-3-N
80	1497-B-HXJX-3-N	1497-B-HXDX-3-N	1497-B-AXJK-3-N	1497-B-AXSX-3-N	1497-B-BAJK-3-N	1497-B-BASX-3-N
130	1497-C-HXJX-3-N	1497-C-HXDX-3-N	1497-C-AXJK-3-N	1497-C-AXSX-3-N	1497-C-BAJK-3-N	1497-C-BASX-3-N
200	1497-D-HXJX-3-N	1497-D-HXDX-3-N	1497-D-AXJK-3-N	1497-D-AXSX-3-N	1497-D-BAJK-3-N	1497-D-BASX-3-N
250	1497-E-HXJX-3-N	1497-E-HXDX-3-N	1497-E-AXJK-3-N	1497-E-AXSX-3-N	1497-E-BAJK-3-N	1497-E-BASX-3-N
350	1497-F-HXJX-3-N	1497-F-HXDX-3-N	1497-F-AXJK-3-N	1497-F-AXSX-3-N	1497-F-BAJK-3-N	1497-F-BASX-3-N
500	1497-G-HXJX-3-N	1497-G-HXDX-3-N	1497-G-AXJK-3-N	1497-G-AXSX-3-N	1497-G-BAJK-3-N	1497-G-BASX-3-N

(1) Top-mounted fuse blocks are not available for transformers 750VA and higher.

	Cat. Nos.		
	Primary ⁽¹⁾ 600V (60 Hz)/550V (50 Hz)		Primary 380V, 400V, 415V (50 Hz)
Continuous VA	Secondary 26V (60 Hz)/24V (50 Hz)	Secondary 120V (60 Hz)/110V (50 Hz)	Secondary 115V/230V (50 Hz)
63	1497-A-CXJK-0-N	1497-A-CXSX-0-N	1497-A-M4-0-N
80	1497-B-CXJK-0-N	1497-B-CXSX-0-N	1497-B-M4-0-N
130	1497-C-CXJK-0-N	1497-C-CXSX-0-N	1497-C-M4-0-N
200	1497-D-CXJK-0-N	1497-D-CXSX-0-N	1497-D-M4-0-N
250	1497-E-CXJK-0-N	1497-E-CXSX-0-N	1497-E-M4-0-N
350	1497-F-CXJK-0-N	1497-F-CXSX-0-N	1497-F-M4-0-N
500	1497-G-CXJK-0-N	1497-G-CXSX-0-N	1497-G-M4-0-N
750	1497-H-CXJK-0-N	1497-H-CXSX-0-N	1497-H-M4-0-N
800	1497-J-CXJK-0-N	1497-J-CXSX-0-N	1497-J-M4-0-N
1000	1497-K-CXJK-0-N	1497-K-CXSX-0-N	1497-K-M4-0-N
1600	—	1497-L-CXSX-0-N	1497-L-M4-0-N
2000	—	1497-M-CXSX-0-N	1497-M-M4-0-N

With 2-Pole Primary and 1-Pole Secondary Top-Mounted Fuse Block⁽²⁾— Fuses Not Included

63	1497-A-CXJK-3-N	1497-A-CXSX-3-N	1497-A-M4-3-N
80	1497-B-CXJK-3-N	1497-B-CXSX-3-N	1497-B-M4-3-N
130	1497-C-CXJK-3-N	1497-C-CXSX-3-N	1497-C-M4-3-N
200	1497-D-CXJK-3-N	1497-D-CXSX-3-N	1497-D-M4-3-N
250	1497-E-CXJK-3-N	1497-E-CXSX-3-N	1497-E-M4-3-N
350	1497-F-CXJK-3-N	1497-F-CXSX-3-N	1497-F-M4-3-N
500	1497-G-CXJK-3-N	1497-G-CXSX-3-N	1497-G-M4-3-N

(1) Transformers 500...800VA with 500V primary do not carry the CE mark.
 (2) Top-mounted fuse blocks are not available for transformers 750VA and higher.

Fuse Sizing Charts

Select the fuse to protect the control circuit conductors in accordance with the National Electrical Code (NEC).

Table 3 - Primary Fuse Sizing Chart (When Only Primary Protection is Used)⁽¹⁾

VA	208V	220V	240V	277V	347V	380V	400V	415V	440V	480V	500V	550V	600V	690V
63	0.75	0.75	0.75	0.5	0.5	0.4	0.4	0.4	0.4	0.25	0.25	0.25	0.25	0.25
80	1	1	1	0.75	0.5	0.5	0.5	0.5	0.5	0.5	0.4	0.4	0.4	0.25
130	1.5	1.5	1.5	1.25	1	1	0.75	0.75	0.75	0.75	0.75	0.5	0.5	0.5
200	2.5	2.5	2.5	2	1.5	1.5	1.5	1.25	1.25	1.25	1	1	1	0.75
250	3	3	3	2.5	2	1.5	1.5	1.5	1.5	1.5	1.5	1.25	1.25	1
350	5	4	4	3	3	2.5	2.5	2.5	2	2	2	1.5	1.5	1.5
500	4	3	3	5	4	3	3	3	3	3	3	2.5	2.5	2
750	6	5	5	4	3	5	5	5	5	4	4	4	3	3
800	6	6	5	4	3	3	3	5	5	5	4	4	4	3

Table 3 - Primary Fuse Sizing Chart (When Only Primary Protection is Used)⁽¹⁾

1000	8	7	6	6	4	4	4	4	3	3	3	5	5	4
1600	12	12	11	9	7	7	6	6	6	5	5	4	4	3
2000	12	11	13	12	9	8	8	8	7	6	6	6	5	4

(1) Maximum Amp Rating for Current Limiting Fuses Based on Transformer Primary Voltage and the National Electrical Code.

Table 4 - Primary Fuse Sizing Chart (When Primary and Secondary Protection is Used)⁽¹⁾

VA	208V	220V	240V	277V	347V	380V	400V	415V	440V	480V	500V	550V	600V	690V
63	0.75	0.75	0.5	0.5	0.4	0.4	0.4	0.4	0.3	0.3	0.3	0.25	0.25	0.25
80	1.5	1.5	1.5	1	1	1	1	0.75	0.75	0.75	0.75	0.5	0.5	0.5
130	3	2.5	2.5	2	1.5	1.5	1.5	1.5	1.25	1.25	1.25	1	1	0.75
200	4	4	4	3	2.5	2.5	2.5	2	2	2	2	1.5	1.5	1
250	6	5	5	4	3	3	3	3	2.5	2.5	2.5	2	2	1.5
350	8	7	7	6	5	4	4	4	3	3	3	3	2.5	2.5
500	6	5	5	9	7	6	6	6	5	5	5	4	4	3
750	9	8	7	6	5	9	9	9	8	7	7	6	6	5
800	9	9	8	7	5	5	5	8	8	8	8	7	6	5
1000	12	10	10	9	7	6	6	6	5	5	5	8	8	7
1600	15	15	15	12	11	10	10	9	9	8	8	7	6	5
2000	20	20	20	18	14	12	12	12	10	10	10	9	8	7

(1) Maximum Amp Rating for Current Limiting Fuses Based on Transformer Primary Voltage and the National Electrical Code.

Table 5 - Secondary Fuse Sizing Chart⁽¹⁾

VA	24V	110V	115V	120V	230V
63	4	0.75	0.75	0.75	0.4
80	5	1	1	1	0.5
130	9	1.8	1.8	1.8	0.9
200	13	2.5	2.5	2.5	1.25
250	15	3.2	3.2	3.2	1.5
350	20	4.5	4.5	4.5	2.5
500	30	6.25	6.25	6.25	3
750	45	9	9	9	4.5
800	45	9	9	9	4.5
1000	60	12	12	12	6
1600	100	20	20	20	10
2000	—	25	25	25	12

(1) Maximum Amp Rating for Current Limiting Fuses Based on the National Electrical Code.

Table 6 - 1497 Global Control Circuit Transformers Specifications per Ecodesign Regulation (EU) 548/2014 and its amendments

Catalog Number ⁽¹⁾	Rated Power (VA)	Primary Voltage	Secondary Voltage	Hertz	Core	Core Weight (lb)	Conductor	Conductor Weight (lb)	Full Load Losses (Watts)	No Load Losses (Watts)
1497-K-HXJX-O-N	1000	208V (60 Hz)	24V (60Hz)	60	Steel	26.3	Copper	5.5	93	55.2
1497-K-HXDX-O-N	1000	208V (60 Hz)	120V (60 Hz)	60		26.3		5.5	64.9	41.6
1497-K-AXJK-O-N	1000	240V (60 Hz)/220V (50 Hz)	26V (60 Hz)/24V (50 Hz)	50/60		26.3		6.3	57.9	36.0
1497-K-AXSX-O-N	1000	240V (60 Hz)/220V (50 Hz)	120V (60 Hz)/110V (50 Hz)	50/60		26.3		5.7	59.4	38
1497-K-BAJK-O-N	1000	240X480V (60Hz)/220X440V (50Hz)	26V (60 Hz)/24V (50 Hz)	50/60		26.3		6.3	76	38.2
1497-K-BASX-O-N	1000	240X480V (60Hz)/220X440V (50Hz)	120V (60 Hz)/110V (50 Hz)	50/60		26.3		5.5	54	34.6
1497-K-CXJK-O-N	1000	600V (60 Hz)/550V (50 Hz)	26V (60 Hz)/24V (50 Hz)	50/60		26.3		5.05	68.4	48.7
1497-K-CXSX-O-N	1000	600V (60 Hz)/550V (50 Hz)	120V (60 Hz)/110V (50 Hz)	50/60		26.3		4.8	74.5	47.5
1497-K-M4-O-N	1000	380V, 400V, 415V (50 Hz)	115V/230V (50 Hz)	50		26.3		5.5	72	58
1497-L-HXDX-O-N	1600	208V (60 Hz)	120V (60 Hz)	60		36.6		6.3	99	68
1497-L-AXSX-O-N	1600	240V (60 Hz)/220V (50 Hz)	120V (60 Hz)/110V (50 Hz)	50/60		35.8		6.8	100.5	69.3
1497-L-BASX-O-N	1600	240X480V (60Hz)X220/440V (50Hz)	120V (60 Hz)/110V (50 Hz)	50/60		35.8		6.4	92.3	55.2
1497-L-CXSX-O-N	1600	600V (60 Hz)/550V (50 Hz)	120V (60 Hz)/110V (50 Hz)	50/60		35.8		7.1	86.4	63.2
1497-L-M4-O-N	1600	380V, 400V, 415V (50 Hz)	115V/230V (50 Hz)	50		35.8		7.4	97.1	69.3
1497-M-HXDX-O-N	2000	208V (60 Hz)	120V (60 Hz)	60		46.1		7.8	114.3	87.2
1497-M-AXSX-O-N	2000	240V (60 Hz)/220V (50 Hz)	120V (60 Hz)/110V (50 Hz)	50/60		46.1		9	110	81.1
1497-M-BASX-O-N	2000	240X480V (60Hz)/220X440V (50Hz)	120V (60 Hz)/110V (50 Hz)	50/60		46.1		7.6	102	56.9
1497-M-CXSX-O-N	2000	600V (60 Hz)/550V (50 Hz)	120V (60 Hz)/110V (50 Hz)	50/60		46.1		8.8	99.8	75
1497-M-M4-O-N	2000	380V, 400V, 415V (50 Hz)	115V/230V (50 Hz)	50		46.1		9.1	106	72.6

(1) All catalog numbers listed on this table do not require any cooling system.

Approximate Dimensions

Dimensions are shown in inches (millimeters). Dimensions are not intended to be used for manufacturing purposes.

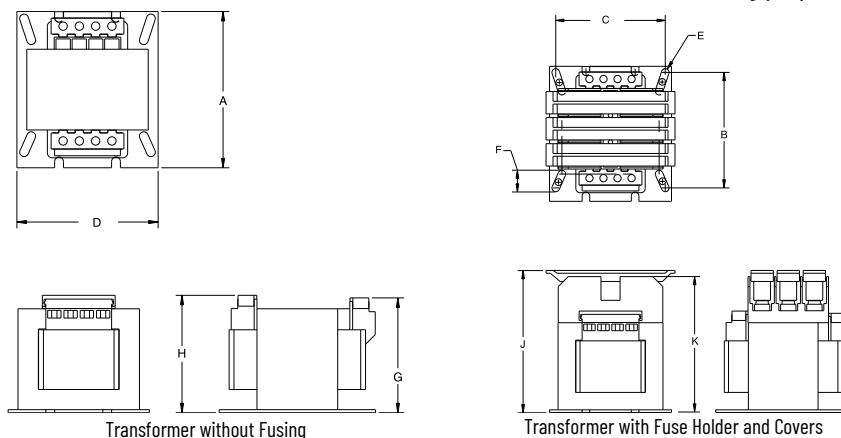

VA	A	B	C	D	E	F	G	H	J	K	Approximate Shipping Wt. – lb (kg)	
											Without Top-Mounted Fuse Block	2-Pole Primary and 1-Pole Secondary Top-Mounted Fuse Block
63	3-7/8 (98.00)	3-1/4 (82.55)	3-1/8 (79.38)	3-1/2 (88.90)	7/32 (5.54)	22/32 (18.29)	2-27/32 (72.39)	2-3/8 (73.91)	4-5/64 (103.51)	3-57/64 (99.01)	4-1/2 (2.04)	4-4/5 (2.18)
80	3-7/8 (98.00)	3-1/4 (82.55)	3-1/8 (79.38)	3-1/2 (88.90)	7/32 (5.54)	22/32 (18.29)	2-27/32 (72.39)	2-3/8 (73.91)	4-5/64 (103.51)	3-57/64 (99.01)	4-1/2 (2.04)	4-4/5 (2.18)
130	3-7/8 (98.00)	3-1/4 (82.55)	3-1/8 (79.38)	3-1/2 (88.90)	7/32 (5.54)	22/32 (18.29)	3-3/8 (85.60)	3-13/32 (86.61)	4-45/64 (119.5)	4-35/64 (115.44)	6-7/10 (3.04)	7-3/20 (3.24)

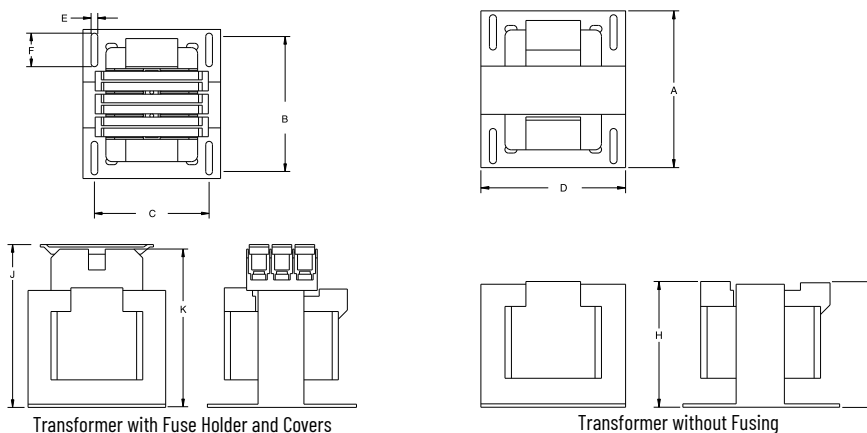

VA	A	B	C	D	E	F	G	H	J	K	Approximate Shipping Wt. – lb (kg)	
											Without Top-Mounted Fuse Block	2-Pole Primary and 1-Pole Secondary Top-Mounted Fuse Block
200	4-7/8 (123.95)	4-7/16 (112.78)	3-3/4 (95.25)	4-1/2 (114.30)	7/32 (5.59)	1-1/8 (28.70)	3-3/8 (85.60)	3-29/32 (86.61)	5-21/64 (135.26)	5-11/64 (131.44)	8-2/5 (3.81)	8-7/10 (3.95)
250	4-7/8 (123.95)	4-7/16 (108.20)	3-3/4 (95.25)	4-1/2 (114.30)	7/32 (5.59)	1-1/8 (28.70)	3-7/8 (98.30)	3-29/32 (98.30)	5-21/64 (135.26)	5-11/64 (131.44)	10-2/5 (4.72)	10-4/5 (4.90)
350	4-7/8 (123.95)	4-7/16 (108.20)	3-3/4 (95.25)	4-1/2 (114.30)	7/32 (5.59)	1-1/8 (28.70)	3-7/8 (98.30)	3-29/32 (98.30)	5-21/64 (135.26)	5-11/64 (131.44)	13-2/5 (6.08)	13-4/5 (6.26)

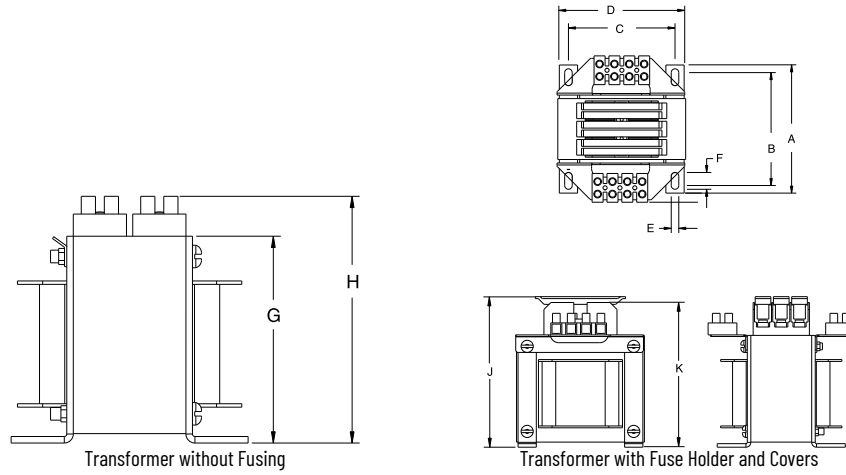

VA	A	B	C	D	E	F	G	H	J	K	Approximate Shipping Wt. – lb (kg)	
											Without Top-Mounted Fuse Block	2-Pole Primary and 1-Pole Secondary Top-Mounted Fuse Block
500	5-1/4 (133.35)	4-33/64 (114.70)	4-3/8 (111.13)	5-1/4 (133.35)	5/16 (7.94)	45/64 (17.86)	4-17/32 (115.09)	5-1/2 (139.70)	6-3/16 (157.16)	5-15/16 (150.81)	17-3/5 (7.98)	17-19/20 (8.14)

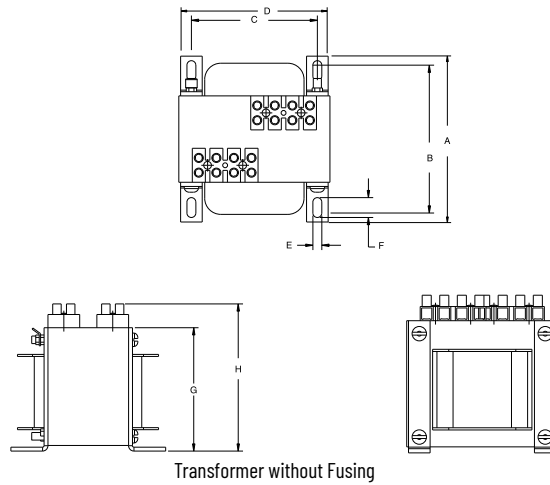

VA	A	B	C	D	E	F	G	H	Approximate Shipping Wt. lb (kg), Without Top-Mounted Fuse Block
750	5-3/4 (146.05)	5 (127.00)	4-3/8 (111.13)	5-1/4 (133.35)	5/16 (7.94)	45/64 (17.86)	4-9/16 (115.89)	5-19/32 (142.08)	21-1/2 (9.75)
800	5-3/4 (146.05)	5 (127.00)	4-3/8 (111.13)	5-1/4 (133.35)	5/16 (7.94)	45/64 (17.86)	4-9/16 (115.89)	5-19/32 (142.08)	21-1/2 (9.75)
1000	6-3/8 (161.93)	5-3/8 (136.53)	5-5/16 (134.94)	6-3/8 (161.93)	5/16 (7.94)	45/64 (17.86)	5-33/64 (140.10)	6-1/2 (165.10)	37-1/5 (16.87)
1600	8-1/2 (215.90)	7-1/4 (184.15)	5-3/4 (146.05)	6-3/4 (171.45)	7/16 (11.11)	45/64 (17.86)	5-3/4 (146.05)	7-1/16 (179.39)	50-4/5 (23.04)
2000	9-1/2 (241.30)	8-1/4 (209.55)	5-3/4 (146.05)	6-3/4 (171.45)	7/16 (11.11)	45/64 (17.86)	5-11/64 (131.37)	7-1/16 (179.39)	61 (27.67)

Bulletin 1497A – Machine Tool Transformers

Bulletin 1497A Machine Tool Transformers are designed to reduce supply voltages to control circuits. The complete line of transformers is available with optional factory-installed or panel-mount primary and secondary fuse block/clip.

- 50...3000VA (50/60 Hz)
- RoHS compliant
- Single phase
- Epoxy encapsulated

Topic	Page
Product Selection	16
Fuse Sizing Charts	17
Approximate Dimensions	19
Estimated Heat Dissipation	21
Accessories	46

Standards Compliance

- UL 5085-2
- CSA C22.2 No. 66.1

Certifications

- cULus Listed (File No. E52057; Guide No. XPTQ, XPTQ7)



Catalog Number Explanation - Bulletin 1497A Machine Tool Transformers

For a complete list of valid transformer configurations, see [Product Selection on page 7](#).

1497A	-	A1	M6	0	N
		a	b	c	d

a		b			c		d	
VA Rating		Primary and Secondary Voltage			Fuse Block Options ⁽¹⁾		Factory Installed Options	
Code	Description [VA]	Code	Primary	Secondary	Code	Block Options	Code	Description
A1	50	M6	220X440V, 230X460V, 240X480V	110, 115, 120V (50/60 Hz)	0	0 Primary, 0 Secondary	N	No Taps
A2	75	M7	230/460/575V	110, 115, 120V (50/60 Hz)	1	0 Primary, 1 Secondary		
A3	100	M8	208/277/380V	115/95V (50/60 Hz)	3	2 Primary, 1 Secondary		
A4	150	M18	208/230/480V (50/60 Hz)	120/24V (50/60 Hz)				
A5	200	M19	240X480V (50/60 Hz)	48V (50/60 Hz)				
A6	250							
A7	300							
A8	350							
A9	500							
A10	750							
A11	1000							
A12	1500							
A13A	2000							
A14	3000							

(1) Transformers rated 350VA and below use secondary fuse clips. Transformers rated 500VA and above use secondary fuse blocks.

Selecting a Machine Tool Transformer

- Total steady-state (sealed) VA is the volt-amperes that the transformer must deliver to the load circuit for an extended period of time - the amount of current required to hold the contact in the circuit.
- Total inrush VA is the volt amperes that the transformer must deliver upon initial energization of the control circuit. Energization of electromagnetic devices takes 30...50 milliseconds. During this inrush period, the electromagnetic control devices draw many times normal current - 3...10 times normal is typical.
- Inrush load power factor is difficult to determine without detailed vector analysis of all the load components. Such an analysis is generally not feasible. Therefore, a safe assumption is 40% power factor (pf).

Selection Process

For proper transformer selection, three characteristics of the load circuit must be determined in addition to the minimum voltage required to operate the circuit. These are total steady-state (sealed) VA, total inrush VA, and inrush load power factor.

- Total steady-state (sealed) VA is the volt-amperes that the transformer must deliver to the load circuit for an extended period of time - the amount of current required to hold the contact in the circuit.
- Total inrush VA is the volt amperes that the transformer must deliver upon initial energization of the control circuit. Energization of electromagnetic devices takes 30...50 milliseconds. During this inrush period, the electromagnetic control devices draw many times normal current - 3...10 times normal is typical.
- Inrush load power factor is difficult to determine without detailed vector analysis of all the load components. Such an analysis is generally not feasible. Therefore, a safe assumption is 40% power factor.

1. Determine the total inrush VA of the control circuits from [Table 8](#). Do not neglect the current requirements of indicating lights and other devices that do not have an inrush VA but are re-energized at the same time as the other components in the circuit. Their total VA should be added to the total inrush VA.
2. Refer to [Table 7](#). If the supply circuit voltage (Step 1) is reasonably stable and fluctuates not more than $\pm 5\%$, refer to the 90% secondary voltage column. If it fluctuates as much as $\pm 10\%$, refer to the 85% secondary voltage column. Go down the column selected until at the inrush VA closest to, but not less than, the inrush VA of the control circuit.
3. Read to the far left side of the chart. The transformer's continuous nominal VA rating is now selected. The secondary voltage that will be delivered under inrush conditions will be either 85%, 90%, or 95% of the rated secondary voltage, depending on the column selected from [Table 7](#). The total sealed VA of the control circuit must not exceed the nominal VA rating of the transformer selected from [Table 8](#).
4. Refer to [Table 9](#) through [Table 11](#) to select a transformer according to the required continuous nominal VA, and primary and secondary voltage combinations.

Table 7 - Regulation Data – Inrush VA

Inrush VA at 40% Power Factor				Power Factor Adjustments	
Nominal VA Rating	85%	90%	95%	Power Factor	Divide By
50	158	139	116	100%	0.63
75	242	213	177	90%	0.65
100	346	302	249	80%	0.70
150	528	461	379	70%	0.75
200	869	743	585	60%	0.82
250	1057	904	719	50%	0.90
300	1418	1200	937	40%	1.00
350	1620	1361	1047	30%	1.12
500	2681	2221	1648	20%	1.27
750	4560	3718	2700	10%	1.45
1000	7568	6118	4185	—	—
1500	15724	12423	8203	—	—
2000	16941	13660	9484	—	—
3000	25680	20180	13797	—	—

Table 8 - Typical Magnetic Motor Starter and Contactor Data 60 Hz, 120 Volt, 3-Pole

Contactor	NEMA Size						
	0	1	2	3	4	5	
Bulletin 500	192	192	240	660	1225	1490	VA Inrush
	29	29	29	45	69	96	VA Sealed

Product Selection

Table 9 - Transformer without Primary or Secondary Fuse Block/Clip⁽¹⁾

Continuous VA	Cat. Nos.				
	Primary 220x440V, 230x460V, 240x480V (50/60 Hz)	Primary 230/460/575V (50/60 Hz)	Primary 208/277/380V (50/60 Hz)	Primary 208/230/480V (50/60 Hz)	Primary 240X480V (50/60 Hz)
	Secondary 110, 115, 120V	Secondary 115/95V	Secondary 115/95V	Secondary 120/24V	Secondary 48V
50	1497A-A1-M6-0-N	1497A-A1-M7-0-N	1497A-A1-M8-0-N	1497A-A1-M18-0-N	1497A-A1-M19-0-N
75	1497A-A2-M6-0-N	1497A-A2-M7-0-N	1497A-A2-M8-0-N	1497A-A2-M18-0-N	1497A-A2-M19-0-N
100	1497A-A3-M6-0-N	1497A-A3-M7-0-N	1497A-A3-M8-0-N	1497A-A3-M18-0-N	1497A-A3-M19-0-N
150	1497A-A4-M6-0-N	1497A-A4-M7-0-N	1497A-A4-M8-0-N	1497A-A4-M18-0-N	1497A-A4-M19-0-N
200	1497A-A5-M6-0-N	1497A-A5-M7-0-N	1497A-A5-M8-0-N	1497A-A5-M18-0-N	1497A-A5-M19-0-N
250	1497A-A6-M6-0-N	1497A-A6-M7-0-N	1497A-A6-M8-0-N	1497A-A6-M18-0-N	1497A-A6-M19-0-N
300	1497A-A7-M6-0-N	1497A-A7-M7-0-N	1497A-A7-M8-0-N	1497A-A7-M18-0-N	1497A-A7-M19-0-N
350	1497A-A8-M6-0-N	1497A-A8-M7-0-N	1497A-A8-M8-0-N	1497A-A8-M18-0-N	1497A-A8-M19-0-N
500	1497A-A9-M6-0-N	1497A-A9-M7-0-N	1497A-A9-M8-0-N	—	1497A-A9-M19-0-N
750	1497A-A10-M6-0-N	1497A-A10-M7-0-N	1497A-A10-M8-0-N	—	1497A-A10-M19-0-N
1000	1497A-A11-M6-0-N	1497A-A11-M7-0-N	1497A-A11-M8-0-N	—	1497A-A11-M19-0-N
1500	1497A-A12-M6-0-N	1497A-A12-M7-0-N	1497A-A12-M8-0-N	—	—
2000	1497A-A13-M6-0-N	1497A-A13-M7-0-N	1497A-A13-M8-0-N	—	—
3000	1497A-A14-M6-0-N	—	—	—	—

(1) Secondary Fuse Block/Clip: Transformers rated 350VA and below use secondary fuse clips. Transformers rated 500VA and above use secondary fuse blocks.

Table 10 - Transformer with 1 Secondary Fuse Block/Clip⁽¹⁾

Continuous VA	Cat. Nos.				
	Primary 220x440V, 230x460V, 240x480V (50/60 Hz)	Primary 230/460/575V (50/60 Hz)	Primary 208/277/380V (50/60 Hz)	Primary 208/230/480V (50/60 Hz)	Primary 240X480V (50/60 Hz)
	Secondary 110, 115, 120V	Secondary 115/95V	Secondary 115/95V	Secondary 120/24V	Secondary 48V
50	1497A-A1-M6-1-N	1497A-A1-M7-1-N	1497A-A1-M8-1-N	1497A-A1-M18-1-N	1497A-A1-M19-1-N
75	1497A-A2-M6-1-N	1497A-A2-M7-1-N	1497A-A2-M8-1-N	1497A-A2-M18-1-N	1497A-A2-M19-1-N
100	1497A-A3-M6-1-N	1497A-A3-M7-1-N	1497A-A3-M8-1-N	1497A-A3-M18-1-N	1497A-A3-M19-1-N
150	1497A-A4-M6-1-N	1497A-A4-M7-1-N	1497A-A4-M8-1-N	1497A-A4-M18-1-N	1497A-A4-M19-1-N
200	1497A-A5-M6-1-N	1497A-A5-M7-1-N	1497A-A5-M8-1-N	1497A-A5-M18-1-N	1497A-A5-M19-1-N
250	1497A-A6-M6-1-N	1497A-A6-M7-1-N	1497A-A6-M8-1-N	1497A-A6-M18-1-N	1497A-A6-M19-1-N
300	1497A-A7-M6-1-N	1497A-A7-M7-1-N	1497A-A7-M8-1-N	1497A-A7-M18-1-N	1497A-A7-M19-1-N
350	1497A-A8-M6-1-N	1497A-A8-M7-1-N	1497A-A8-M8-1-N	1497A-A8-M18-1-N	1497A-A8-M19-1-N

Table 10 - Transformer with 1 Secondary Fuse Block/Clip⁽¹⁾

500	1497A-A9-M6-1-N	1497A-A9-M7-1-N	1497A-A9-M8-1-N	—	1497A-A9-M19-1-N
750	1497A-A10-M6-1-N	1497A-A10-M7-1-N	1497A-A10-M8-1-N	—	1497A-A10-M19-1-N
1000	1497A-A11-M6-1-N	1497A-A11-M7-1-N	1497A-A11-M8-1-N	—	1497A-A11-M19-1-N
1500	1497A-A12-M6-1-N	1497A-A12-M7-1-N	1497A-A12-M8-1-N	—	—
2000	1497A-A13-M6-1-N	1497A-A13-M7-1-N	1497A-A13-M8-1-N	—	—
3000	1497A-A14-M6-1-N	—	—	—	—

(1) Secondary Fuse Block/Clip: Transformers rated 350VA and below use secondary fuse clips. Transformers rated 500VA and above use secondary fuse blocks.

Table 11 - Transformer with 2 Primary and 1 Secondary Fuse Block/Clip⁽¹⁾

Continuous VA	Cat. Nos.				
	Primary 220x440V, 230x460V, 240x480V (50/60 Hz)	Primary 230/460/575V (50/60 Hz)	Primary 208/277/380V (50/60 Hz)	Primary 208/230/480V (50/60 Hz)	Primary 240x480V (50/60 Hz)
Secondary 110, 115, 120V	Secondary 115/95V	Secondary 115/95V	Secondary 120/24V	Secondary 48V	
50	1497A-A1-M6-3-N	1497A-A1-M7-3-N	1497A-A1-M8-3-N	1497A-A1-M18-3-N	1497A-A1-M19-3-N
75	1497A-A2-M6-3-N	1497A-A2-M7-3-N	1497A-A2-M8-3-N	1497A-A2-M18-3-N	1497A-A2-M19-3-N
100	1497A-A3-M6-3-N	1497A-A3-M7-3-N	1497A-A3-M8-3-N	1497A-A3-M18-3-N	1497A-A3-M19-3-N
150	1497A-A4-M6-3-N	1497A-A4-M7-3-N	1497A-A4-M8-3-N	1497A-A4-M18-3-N	1497A-A4-M19-3-N
200	1497A-A5-M6-3-N	1497A-A5-M7-3-N	1497A-A5-M8-3-N	1497A-A5-M18-3-N	1497A-A5-M19-3-N
250	1497A-A6-M6-3-N	1497A-A6-M7-3-N	1497A-A6-M8-3-N	1497A-A6-M18-3-N	1497A-A6-M19-3-N
300	1497A-A7-M6-3-N	1497A-A7-M7-3-N	1497A-A7-M8-3-N	1497A-A7-M18-3-N	1497A-A7-M19-3-N
350	1497A-A8-M6-3-N	1497A-A8-M7-3-N	1497A-A8-M8-3-N	1497A-A8-M18-3-N	1497A-A8-M19-3-N
500	1497A-A9-M6-3-N	1497A-A9-M7-3-N	1497A-A9-M8-3-N	—	1497A-A9-M19-3-N
750	1497A-A10-M6-3-N	1497A-A10-M7-3-N	1497A-A10-M8-3-N	—	1497A-A10-M19-3-N
1000	1497A-A11-M6-3-N	1497A-A11-M7-3-N	1497A-A11-M8-3-N	—	1497A-A11-M19-3-N
1500	1497A-A12-M6-3-N	1497A-A12-M7-3-N	1497A-A12-M8-3-N	—	—
2000	1497A-A13-M6-3-N	1497A-A13-M7-3-N	1497A-A13-M8-3-N	—	—
3000	1497A-A14-M6-3-N	—	—	—	—

(1) Secondary Fuse Block/Clip: Transformers rated 350VA and below use secondary fuse clips. Transformers rated 500VA and above use secondary fuse blocks.

Fuse Sizing Charts

Select the fuse to protect the control circuit conductors in accordance with the National Electrical Code.

Table 12 - Primary Fuse Sizing Chart (When only primary protection is used)⁽¹⁾

VA	115V	120V	200V	208V	220V	230V	240V	277V	380V	400V	415V	440V	460V	480V	500V	550V	575V	600V
50	1.25	1.25	0.75	0.6	0.6	0.6	0.6	0.5	0.3	0.3	0.3	0.3	0.3	0.3	0.3	0.25	0.25	0.25
75	1.8	1.8	1.125	1	1	0.75	0.75	0.75	0.5	0.5	0.5	0.5	0.4	0.4	0.4	0.4	0.3	0.3
100	2.5	2.5	1.5	1.4	1.25	1.25	1.25	1	0.75	0.75	0.6	0.6	0.6	0.6	0.6	0.5	0.5	0.5
150	3.5	3.5	2.25	2	2	1.8	1.8	1.6	1.125	1.125	1	1	0.75	0.75	0.75	0.75	0.75	0.75
200	5	5	3	2.8	2.5	2.5	2.5	2	1.5	1.5	1.4	1.25	1.25	1.25	1.125	1	1	1
250	3.5	3.2	3.5	3.5	3.2	3.2	3	2.5	1.8	1.8	1.8	1.6	1.6	1.5	1.5	1.25	1.25	1.25
300	4	4	4.5	4	4	3.5	3.5	3.2	2.25	2.25	2	2	1.8	1.8	1.8	1.6	1.5	1.5
350	5	4.5	5	5	4.5	4.5	4	3.5	2.5	2.5	2.5	2.25	2.25	2	2	1.8	1.8	1.6

Table 12 - Primary Fuse Sizing Chart (When only primary protection is used)⁽¹⁾

500	7	6.25	4	4	3.5	3.5	3.2	5	3.5	3.5	3.5	3.2	3.2	3	3	2.5	2.5	2.5
750	10	10	6.25	6	5.6	5	5	4.5	5.6	5.6	5	5	4.5	4.5	4.5	4	3.5	3.5
1000	12	12	8	8	7	7	6.25	6	4	4	4	3.5	3.5	3.2	3.2	5	5	5
1500	20	15	12	12	10	10	10	9	6.25	6.25	6	5.6	5	5	5	4.5	4	4
2000	20	20	12	12	10	12	12	12	8	8	8	7	7	6.25	6.25	6	5.6	5
3000	30	30	15	15	15	15	15	12	12	12	12	10	10	10	10	9	8	8

(1) Maximum Amp Rating for Current Limiting Class C Fuses Based on Transformer Primary Voltage and the National Electrical Code.

Table 13 - Primary Fuse Sizing Chart (When primary and secondary protection is used)⁽¹⁾

VA	115V	120V	200V	208V	220V	230V	240V	277V	380V	400V	415V	440V	460V	480V	500V	550V	575V	600V
50	1	1	0.6	0.6	0.5	0.5	0.5	0.4	0.3	0.3	0.3	0.25	0.25	0.25	0.25	0.2	0.2	0.2
75	1.6	1.5	0.75	0.75	0.75	0.75	0.75	0.6	0.4	0.4	0.4	0.4	0.4	0.3	0.3	0.3	0.3	0.3
100	2	2	1.25	1.125	1.125	1	1	0.75	0.6	0.6	0.6	0.5	0.5	0.5	0.5	0.4	0.4	0.4
150	3.2	3	1.8	1.8	1.6	1.6	1.5	1.25	0.75	0.75	0.75	0.75	0.75	0.75	0.75	0.6	0.6	0.6
200	4	4	2.5	2.25	2	2	2	1.8	1.25	1.25	1.125	1.125	1	1	1	0.75	0.75	0.75
250	5	5	3	3	2.8	2.5	2.5	2.25	1.6	1.5	1.5	1.4	1.25	1.25	1.25	1.125	1	1
300	6.25	6.25	3.5	3.5	3.2	3.2	3	2.5	1.8	1.8	1.8	1.6	1.6	1.5	1.5	1.25	1.25	1.25
350	7	7	4	4	3.5	3.5	3.5	3	2.25	2	2	1.8	1.8	1.8	1.6	1.5	1.5	1.4
500	10	10	6.25	6	5.6	5	5	4.5	3.2	3	3	2.8	2.5	2.5	2.5	2.25	2	2
750	15	15	9	9	8	8	7	6.25	4.5	4.5	4.5	4	4	3.5	3.5	3.2	3.2	3
1000	20	20	12	12	10	10	10	9	6.25	6.25	6	5.6	5	5	5	4.5	4	4
1500	30	30	15	15	15	15	15	12	9	9	9	8	8	7	7	6.25	6.25	6.25
2000	40	40	25	20	20	20	20	15	12	12	12	10	10	10	10	9	8	8
3000	45	45	35	35	30	30	30	25	15	15	15	15	15	15	15	12	12	12

(1) Maximum Amp rating for current limiting fuses based on transformer primary voltage and the National Electrical Code.

Table 14 - Secondary Fuse Sizing Chart⁽¹⁾

VA	23V	24V	25V	85V	90V	95V	100V	110V	115V	120V	125V	130V	220V	230V	240V
50	3.5	3.2	3.2	0.75	0.75	0.75	0.75	0.75	0.6	0.6	0.6	0.6	0.3	0.3	0.3
75	5	5	5	1.4	1.25	1.25	1.25	1.125	1	1	1	0.75	0.5	0.5	0.5
100	7	6.25	6.25	1.8	1.8	1.6	1.6	1.5	1.4	1.25	1.25	1.25	0.75	0.6	0.6
150	10	10	10	2.8	2.5	2.5	2.5	2.25	2	2	2	1.8	1.125	1	1
200	12	12	12	3.5	3.5	3.5	3.2	3	2.8	2.5	2.5	2.5	1.5	1.4	1.25
250	15	15	15	4.5	4.5	4	4	3.5	3.5	3.2	3.2	3.2	1.8	1.8	1.6
300	20	20	20	5.6	5	5	5	4.5	4	4	4	3.5	2.25	2	2
350	20	20	20	6.25	6.25	6	5.6	5	5	4.5	4.5	4	2.5	2.5	2.25
500	—	—	—	9	9	8	8	7	7	6.25	6.25	6.25	3.5	3.5	3.2
750	—	—	—	12	12	12	12	10	10	10	10	9	5.6	5	5
1000	—	—	—	15	15	15	15	15	12	12	12	12	7	7	6.25
1500	—	—	—	25	25	25	25	20	20	20	20	15	10	10	10
2000	—	—	—	35	35	35	30	30	25	25	25	25	15	12	12
3000	—	—	—	—	—	—	—	45	40	40	40	35	20	20	20

(1) Maximum Amp rating for current limiting midjet fuses based on the National Electrical Code.

Approximate Dimensions

Dimensions are shown in inches (millimeters). Dimensions are not intended to be used for manufacturing purposes.

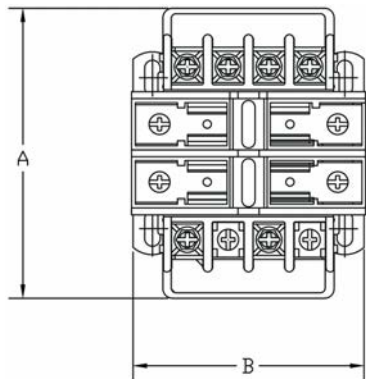

Transformer with 2 Primary Fuse Blocks and 0 or 1 Secondary Fuse Block/Clip (Top View)

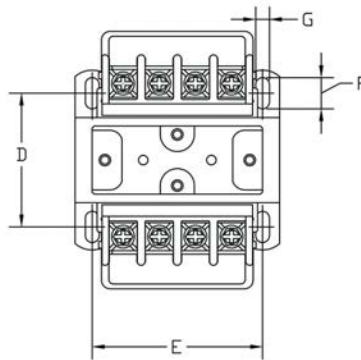

Transformer with 0 Primary Fuse Blocks and 0 or 1 Secondary Fuse Block/Clip (Top View)

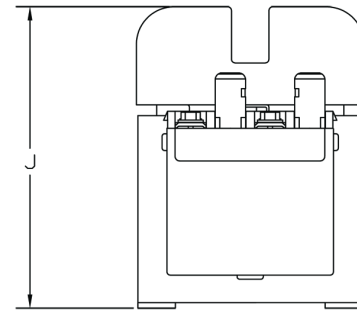

Transformer with 2 Primary Fuse Blocks and 1 Secondary Fuse Block/Clip (Side View)

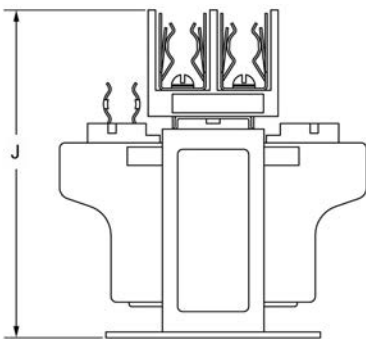

Transformer with 2 Primary Fuse Blocks and 1 Secondary Fuse Block/Clip (Side View)

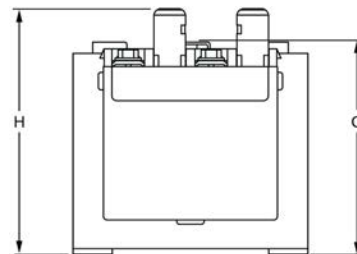

Transformer with 0 Primary Fuse Block and Secondary Fuse Block/Clip (Side View)

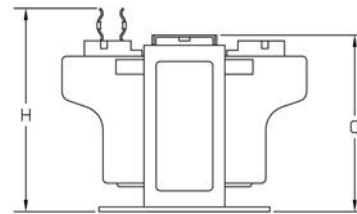

Transformer with 0 Primary Fuse Blocks and 1 Secondary Fuse Block/Clip (Side View)

Table 15 - Approximate Dimensions

VA	Cat. No.	A	B	C	D	E	F	G	H	J	Approx. Shipping Wt. lb (kg)							
50	1497A-A1-M6-_-N	3-25/32 (96)	3 (76)	2-23/32 (69)	1-31/32 (50)	2-1/2 (64)	15/32 (12)	1/5 (5)	3-9/64 (80)	4-1/32 (102)	3 (1.4)							
	1497A-A1-M7-_-N	4-1/32 (102)			2-1/5 (56)						4 (1.8)							
	1497A-A1-M8-_-N	4-17/32 (115)			2-53/64 (72)						4 (1.8)							
	1497A-A1-M18-_-N	3-25/32 (96)			1-31/32 (50)						4 (1.8)							
	1497A-A1-M19-_-N	4-1/32 (102)			2-27/64 (61)						4 (1.8)							
75	1497A-A2-M6-_-N	4-1/32 (102)	3 (76)	2-23/32 (69)	2-5/8 (67)	2-1/2 (64)	15/32 (12)	1/5 (5)	3-9/64 (80)	4-1/32 (102)	5 (2.3)							
	1497A-A2-M7-_-N	4-17/32 (115)			3 (76)						2-13/16 (71)	5 (2.3)						
	1497A-A2-M8-_-N	3-3/8 (86)			3-3/64 (77)						3 (76)	2-13/16 (71)	5 (2.3)					
	1497A-A2-M18-_-N	4-1/32 (102)			3 (76)						2-23/32 (69)	2-27/64 (61)	2-1/2 (64)	3-9/64 (80)	4-1/32 (102)	5 (2.3)		
	1497A-A2-M19-_-N	4-1/32 (102)			3 (76)						2-23/32 (69)	2-27/64 (61)	2-1/2 (64)	3-9/64 (80)	4-1/32 (102)	5 (2.3)		
100	1497A-A3-M6-_-N	4 (102)	3-3/8 (86)	3-3/64 (77)	2-27/64 (61)	2-13/16 (71)	15/32 (12)	1/5 (5)	3-15/32 (88)	4-23/64 (110)	5 (2.3)							
	1497A-A3-M7-_-N	4-1/16 (103)	3-3/4 (95)	3-23/64 (85)	2-13/16 (71)	3-5/16 (80)					3-49/64 (96)	4-21/32 (118)	6 (2.7)					
	1497A-A3-M8-_-N	4-17/32 (115)			3 (76)								6 (2.7)					
	1497A-A3-M18-_-N	4 (102)			3-3/8 (86)								3-3/64 (77)	2-27/64 (61)	2-13/16 (71)	3-15/32 (88)	4-23/64 (110)	6 (2.7)
	1497A-A3-M19-_-N	4 (102)			3-3/8 (86)								3-3/64 (77)	2-27/64 (61)	2-13/16 (71)	3-15/32 (88)	4-23/64 (110)	6 (2.7)

Table 15 - Approximate Dimensions (Continued)

VA	Cat. No.	A	B	C	D	E	F	G	H	J	Approx. Shipping Wt. lb (kg)							
150	1497A-A4-M6--N	4-1/16 (103)	3-3/4 (95)	3-23/64 (85)	2-13/16 (71)	3-5/16 (80)	15/32 (12)	1/5 (5)	3-49/64 (96)	4-21/32 (118)	6 (2.7)							
	1497A-A4-M7--N	4-17/32 (115)			3-3/16 (81)				3-25/32 (96)		7 (3.2)							
	1497A-A4-M8--N	5-1/16 (129)			2-13/16 (71)				3-49/64 (96)		7 (3.2)							
	1497A-A4-M18--N	4-1/16 (103)							7 (3.2)									
	1497A-A4-M19--N	4-1/16 (103)							7 (3.2)									
200	1497A-A5-M6--N	4-3/8 (111)	4-1/2 (114)	3-31/32 (101)	2-5/8 (67)	3-3/4 (95)	15/32 (12)	1/5 (5)	4-2/5 (112)	5-9/32 (134)	10 (4.5)							
	1497A-A5-M7--N				2-63/64 (76)						10 (4.5)							
	1497A-A5-M8--N										2-5/8 (67)	10 (4.5)						
	1497A-A5-M18--N										2-5/8 (67)	10 (4.5)						
	1497A-A5-M19--N				2-5/8 (67)						10 (4.5)							
250	1497A-A6-M6--N	4-3/8 (111)	4-1/2 (114)	3-31/32 (101)	2-53/64 (72)	3-3/4 (95)	15/32 (12)	1/5 (5)	4-2/5 (112)	5-9/32 (134)	10 (4.5)							
	1497A-A6-M7--N				3-15/32 (88)						10 (4.5)							
	1497A-A6-M8--N										2-53/64 (72)	10 (4.5)						
	1497A-A6-M18--N	4-3/4 (120)			10 (4.5)													
	1497A-A6-M19--N	4-3/8 (111)			10 (4.5)													
300	1497A-A7-M6--N	4-3/4 (120)	4-1/2 (114)	3-31/32 (101)	3-3/16 (81)	3-3/4 (95)	15/32 (12)	1/5 (5)	4-2/5 (112)	5-9/32 (134)	12 (5.4)							
	1497A-A7-M7--N				3-7/8 (98)						12 (5.4)							
	1497A-A7-M8--N										4-3/8 (111)	12 (5.4)						
	1497A-A7-M18--N	6-7/64 (155)			5-1/4 (133)						4-5/8 (118)	3-7/8 (98)	4-3/8 (111)	1-1/16 (27)	5/16 (8)	4-2/5 (112)	5-15/16 (151)	12 (5.4)
	1497A-A7-M19--N	4-3/4 (120)			4-1/2 (114)						3-31/32 (101)	3-3/16 (81)	3-3/4 (95)	15/32 (12)	1/5 (5)	4-2/5 (112)	5-9/32 (134)	12 (5.4)
350	1497A-A8-M6--N	4-3/4 (120)	4-1/2 (114)	3-31/32 (101)	3-3/16 (81)	3-3/4 (95)	15/32 (12)	1/5 (5)	4-2/5 (112)	5-9/32 (134)	12 (5.4)							
	1497A-A8-M7--N	4-63/64 (128)			3-3/4 (95)						14 (6.4)							
	1497A-A8-M8--N				3-7/8 (98)						4-3/8 (111)	1-1/16 (27)	5/16 (8)	4-2/5 (112)	5-15/16 (151)	14 (6.4)		
	1497A-A8-M18--N	6-7/64 (155)	5-1/4 (133)		4-5/8 (118)						3-7/8 (98)	4-3/8 (111)	1-1/16 (27)	5/16 (8)	4-2/5 (112)	5-15/16 (151)	14 (6.4)	
	1497A-A8-M19--N	4-3/4 (120)	4-1/2 (114)		3-31/32 (101)						3-3/16 (81)	3-3/4 (95)	15/32 (12)	1/5 (5)	4-2/5 (112)	5-9/32 (134)	14 (6.4)	
500	1497A-A9-M6--N	6-7/64 (155)	5-1/4 (133)	4-5/8 (118)	3-7/8 (98)	4-3/8 (111)	1-1/16 (27)	5/16 (8)	4-2/5 (112)	5-15/16 (151)	19 (8.6)							
	1497A-A9-M7--N										18 (8.2)							
	1497A-A9-M8--N										18 (8.2)							
	1497A-A9-M19--N										18 (8.2)							
750	1497A-A10-M6--N	7-39/64 (193)	5-1/4 (133)	4-5/8 (118)	5-7/8 (149)	4-3/8 (111)	1-1/16 (27)	5/16 (8)	4-2/5 (112)	5-15/16 (151)	28 (12.7)							
	1497A-A10-M7--N	8-7/64 (206)									32 (14.5)							
	1497A-A10-M8--N										31 (14.1)							
	1497A-A10-M19--N	7-39/64 (193)									31 (14.1)							
1000	1497A-A11-M6--N	7-7/64 (181)	6-3/4 (171)	5-55/64 (149)	4-31/32 (126)	6-1/8 (155)	9/10 (23)	5/16 (8)	4-2/5 (112)	7-3/16 (183)	40 (18.1)							
	1497A-A11-M7--N										42 (19.1)							
	1497A-A11-M8--N										41 (18.6)							
	1497A-A11-M19--N										41 (18.6)							
1500	1497A-A12-M6--N	8-7/64 (206)	6-3/4 (171)	5-55/64 (149)	6-1/8 (155)	6-1/8 (155)	7/8 (22)	5/16 (8)	4-2/5 (112)	7-3/16 (183)	53 (24)							
	1497A-A12-M7--N										55 (24.9)							
	1497A-A12-M8--N										54 (24.5)							

Table 15 - Approximate Dimensions (Continued)

VA	Cat. No.	A	B	C	D	E	F	G	H	J	Approx. Shipping Wt. lb (kg)
2000	1497A-A13-M6-_-N	8-7/64 (206)	6-3/4 (171)	5-55/64 (149)	6-1/8 (155)	6-1/8 (155)	7/8 (22)	5/16 (8)	4-2/5 (112)	7-3/16 (183)	53 (24)
	1497A-A13-M7-_-N	9 (229)									61 (27.7)
	1497A-A13-M8-_-N										58 (26.3)
3000	1497A-A14-M6-_-N	8 (203)	9 (229)	7-41/64 (194)	5-1/4 (133)	7-1/2 (191)	9/10 (23)	7/16 (11)	4-2/5 (112)	8-61/64 (227)	72 (32.7)

1497A Transformer Heat Dissipation Specifications

Table 16 - 1497A Estimated Heat Loss

Transformer Size (VA)	Estimated Heat Loss (W)
50	16.2
75	18.6
100	21.0
150	33.7
200	40.1
250	43.4
300	48.4
350	47.9
500	57.1
750	71.2
1000	86.6
1500	104.3
2000	147.3
3000	183.4
5000	241.2

Bulletin 1497B – Control Power Transformers

Bulletin 1497B Control Power Transformers are designed to reduce supply voltages to control circuits. The complete line of transformers is available with optional factory-installed or panel-mount primary and secondary fuse block.

- 50...3000VA (50/60 Hz)
- RoHS compliant
- Single phase
- Epoxy encapsulated

Topic	Page
Product Selection	24
Fuse Sizing Charts	26
Approximate Dimensions	27
Estimated Heat Dissipation	29
Accessories	46



Standards Compliance

- UL 5085-2
- CSA C22.2 No. 66.1

Certifications

- cULus Listed (File No. E52057; Guide No. XPTQ, XPTQ7)

Catalog Number Explanation - Bulletin 1497B Control Power Transformers

For a complete list of valid transformer configurations, see Product Selection.

1497B	-	A3	M11	0	N
		a	b	c	d

a		b		c		d		
VA Rating		Primary and Secondary Voltage		Fuse Block Options ⁽¹⁾		Factory Installed Options		
Code	Description [VA]	Code	Primary	Secondary	Code	Block Options	Code	Description
A1	50	M11	600/575/550V	120X240V (60 Hz)	0	0 Primary, 0 Secondary	N	No Taps
A2	75	M12	120X240V	120X240V (60 Hz)	1	0 Primary, 1 Secondary		
A3	100	M13	120X240V	24V (60 Hz)	2	2 Primary, 0 Secondary		
A4	150	M14	240X480V	120X240V (60 Hz)	3	2 Primary, 1 Secondary		
A5	200	M15	380/400/416V	115X230V (60 Hz)				
A6	250	M16	240X480V	24V (60 Hz)				
A7	300	M17	208/240V	24V (60 Hz)				
A9	500							
A10	750							
A11	1000							
A12	1500							
A13	2000							
A14	3000							

(1) Transformers rated 350VA and below use secondary fuse clips. Transformers rated 500VA and above use secondary fuse blocks.

Selecting a Control Power Transformer

For proper transformer selection, three characteristics of the load circuit must be determined in addition to the minimum voltage required to operate the circuit. These are total steady-state (sealed) VA, total inrush VA, and inrush load power factor.

- Total steady-state (sealed) VA is the volt-amperes that the transformer must deliver to the load circuit for an extended period of time - the amount of current required to hold the contact in the circuit.
- Total inrush VA is the volt amperes that the transformer must deliver upon initial energization of the control circuit. Energization of electromagnetic devices takes 30...50 milliseconds. During this inrush period, the electromagnetic control devices draw many times normal current - 3...10 times normal is typical.
- Inrush load power factor is difficult to determine without detailed vector analysis of all the load components. Such an analysis is generally not feasible. Therefore, a safe assumption is 40% power factor.

Selection Process

1. Determine the total inrush VA of the control circuits from [Table 18](#). Do not neglect the current requirements of indicating lights and other devices that do not have an inrush VA but are re-energized at the same time as the other components in the circuit. Their total VA should be added to the total inrush VA.
2. Refer to [Table 17](#). If the supply circuit voltage (Step 1) is reasonably stable and fluctuates not more than $\pm 5\%$, refer to the 90% secondary voltage column. If it fluctuates as much as $\pm 10\%$, refer to the 85% secondary voltage column. Go down the column selected until at the inrush VA closest to, but not less than, the inrush VA of the control circuit.
3. Read to the far left side of the chart. The transformer's continuous nominal VA rating is now selected. The secondary voltage that will be delivered under inrush conditions will be either 85%, 90%, or 95% of the rated secondary voltage, depending on the column selected from [Table 17](#). The total sealed VA of the control circuit must not exceed the nominal VA rating of the transformer selected from [Table 18](#).
4. Refer to [Table 19](#) through [Table 22](#) to select a transformer according to the required continuous nominal VA, and primary and secondary voltage combinations.

Table 17 - Regulation Data - Inrush VA

Inrush VA at 40% Power Factor				Power Factor Adjustments	
Nominal VA Rating	85%	90%	95%	Power Factor	Divide By
50	158	139	116	100%	0.63
75	242	213	177	90%	0.65
100	346	302	249	80%	0.70
150	528	461	379	70%	0.75
200	869	743	585	60%	0.82
250	1057	904	719	50%	0.90
300	1418	1200	937	40%	1.00
500	2681	2221	1648	20%	1.27
750	4560	3718	2700	10%	1.45
1000	7568	6118	4185	—	—
1500	15724	12423	8203	—	—
2000	16941	13660	9484	—	—
3000	25680	20180	13797	—	—

Table 18 - Typical Magnetic Motor Starter and Contactor Data 60 Hz, 120 Volt, 3-Pole

Contactor	NEMA Size						
	0	1	2	3	4	5	
Bulletin 500	192	192	240	660	1225	1490	VA Inrush
	29	29	29	45	69	96	VA Sealed

Product Selection

Table 19 - Transformers without Fusing Block/Clip⁽¹⁾

Continuous VA	Cat. Nos.						
	Primary 600/575/550V (60 Hz)	Primary 120x240V (60 Hz)	Primary 120x240V (60 Hz)	Primary 240x480V (60 Hz)	Primary 208/240V (60 Hz)	Primary 240x480V (60 Hz)	Primary 380/400/416V (60 Hz)
Secondary 120X240V (60 Hz)	Secondary 120X240V (60 Hz)	Secondary 24V (60 Hz)	Secondary 24V (60 Hz)	Secondary 24V (60 Hz)	Secondary 120X240V (60 Hz)	Secondary 115X230V (60 Hz)	
50	—	—	1497B-A1-M13-0-N	1497B-A1-M16-0-N	1497B-A1-M17-0-N	—	—
75	—	—	1497B-A2-M13-0-N	—	—	—	—
100	1497B-A3-M11-0-N	1497B-A3-M12-0-N	1497B-A3-M13-0-N	1497B-A3-M16-0-N	1497B-A3-M17-0-N	1497B-A3-M14-0-N	—
150	—	—	1497B-A4-M13-0-N	1497B-A4-M16-0-N	1497B-A4-M17-0-N	1497B-A4-M14-0-N	—
200	1497B-A5-M11-0-N	1497B-A5-M12-0-N	1497B-A5-M13-0-N	—	—	1497B-A6-M14-0-N	—
250	—	—	1497B-A6-M13-0-N	1497B-A6-M16-0-N	1497B-A6-M17-0-N	—	—
300	1497B-A7-M11-0-N	1497B-A7-M12-0-N	1497B-A7-M13-0-N	—	—	—	—
500	1497B-A9-M11-0-N	—	—	—	—	1497B-A9-M14-0-N	1497B-A9-M15-0-N
750	—	1497B-A10-M12-0-N	—	—	—	1497B-A10-M14-0-N	1497B-A10-M15-0-N
1000	1497B-A11-M11-0-N	1497B-A11-M12-0-N	—	—	—	1497B-A11-M14-0-N	1497B-A11-M15-0-N
1500	—	—	—	—	—	1497B-A12-M14-0-N	1497B-A12-M15-0-N
2000	1497B-A13-M11-0-N	1497B-A13-M12-0-N	—	—	—	1497B-A13-M14-0-N	1497B-A13-M15-0-N
3000	1497B-A14-M11-0-N	1497B-A14-M12-0-N	—	—	—	1497B-A14-M14-0-N	1497B-A14-M15-0-N

(1) No secondary fusing available.

Table 20 - Transformers with 2 Primary and 0 Secondary Fuse Block/Clip⁽¹⁾

Continuous VA	Cat. Nos.	
	Primary 600/575/550V (60 Hz)	Primary 120X240V (60 Hz)
Secondary 120X240V (60 Hz)	Secondary 120X240V (60 Hz)	
100	1497B-A3-M11-2-N	1497B-A3-M12-2-N
200	1497B-A5-M11-2-N	1497B-A5-M12-2-N
300	1497B-A7-M11-2-N	1497B-A7-M12-2-N

(1) Secondary Fuse Block/Clip: Transformers rated 350VA and below use secondary fuse clips. Transformers rated 500VA and above use secondary fuse blocks.

Table 21 - Transformers with 2 Primary and 1 Secondary Fuse Block/Clip⁽¹⁾

Continuous VA	Cat. Nos.						
	Primary 120x240V (60 Hz)	Primary 240x480V (60 Hz)	Primary 208/240V (60 Hz)	Primary 600/575/550V (60 Hz)	Primary 120x240V (60 Hz)	Primary 240x480V (60 Hz)	Primary 380/400/416V (60 Hz)
Secondary 24V (60 Hz)	Secondary 24V (60 Hz)	Secondary 24V (60 Hz)	Secondary 120X240V (60 Hz)	Secondary 120X240V (60 Hz)	Secondary 120X240V (60 Hz)	Secondary 115X230V (60 Hz)	
50	1497B-A1-M13-3-N	1497B-A1-M16-3-N	1497B-A1-M17-3-N	—	—	—	—
75	1497B-A2-M13-3-N	—	—	—	—	—	—
100	1497B-A3-M13-3-N	1497B-A3-M16-3-N	1497B-A3-M17-3-N	—	—	—	—
150	1497B-A4-M13-3-N	1497B-A4-M16-3-N	1497B-A4-M17-3-N	—	—	—	—
200	1497B-A5-M13-3-N	—	—	—	—	—	—
250	1497B-A6-M13-3-N	1497B-A6-M16-3-N	1497B-A6-M17-3-N	—	—	—	—
300	1497B-A7-M13-3-N	—	—	—	—	—	—
500	—	—	—	1497B-A9-M11-3-N	1497B-A9-M12-3-N	1497B-A9-M14-3-N	1497B-A9-M15-3-N
750	—	—	—	—	1497B-A10-M12-3-N	1497B-A10-M14-3-N	1497B-A10-M15-3-N
1000	—	—	—	1497B-A11-M11-3-N	1497B-A11-M12-3-N	1497B-A11-M14-3-N	1497B-A11-M15-3-N
1500	—	—	—	—	—	1497B-A12-M14-3-N	1497B-A12-M15-3-N
2000	—	—	—	1497B-A13-M11-3-N	1497B-A13-M12-3-N	1497B-A13-M14-3-N	1497B-A13-M15-3-N
3000	—	—	—	1497B-A14-M11-3-N	1497B-A14-M12-3-N	1497B-A14-M14-3-N	1497B-A14-M15-3-N

(1) Secondary Fuse Block/Clip: Transformers rated 350VA and below use secondary fuse clips. Transformers rated 500VA and above use secondary fuse blocks.

Table 22 - Transformers with 0 Primary and 1 Secondary Fuse Block/Clip⁽¹⁾

Continuous VA	Cat. Nos.		
	Primary 120x240V (60 Hz)	Primary 240x480V (60 Hz)	Primary 208/240V (60 Hz)
Secondary 24V (60 Hz)	Secondary 24V (60 Hz)	Secondary 24V (60 Hz)	
50	1497B-A1-M13-1-N	1497B-A1-M16-1-N	1497B-A1-M17-1-N
75	1497B-A2-M13-1-N	—	—
100	1497B-A3-M13-1-N	1497B-A3-M16-1-N	1497B-A3-M17-1-N
150	1497B-A4-M13-1-N	1497B-A4-M16-1-N	1497B-A4-M17-1-N
200	1497B-A5-M13-1-N	—	—
250	1497B-A6-M13-1-N	1497B-A6-M16-1-N	1497B-A6-M17-1-N
300	1497B-A7-M13-1-N	—	—

(1) Secondary Fuse Block/Clip: Transformers rated 350VA and below use secondary fuse clips. Transformers rated 500VA and above use secondary fuse blocks.

Fuse Sizing Charts

Select the fuse to protect the control circuit conductors in accordance with the National Electrical Code.

Table 23 - Primary Fuse Sizing Chart (When only primary protection is used)⁽¹⁾

VA	115V	120V	200V	208V	220V	230V	240V	277V	380V	400V	415V	440V	460V	480V	500V	550V	575V	600V
50	1.25	1.25	0.75	0.6	0.6	0.6	0.6	0.5	0.3	0.3	0.3	0.3	0.3	0.3	0.3	0.25	0.25	0.25
75	1.8	1.8	1.125	1	1	0.75	0.75	0.75	0.5	0.5	0.5	0.5	0.4	0.4	0.4	0.4	0.3	0.3
100	2.5	2.5	1.5	1.4	1.25	1.25	1.25	1	0.75	0.75	0.6	0.6	0.6	0.6	0.6	0.5	0.5	0.5
150	3.5	3.5	2.25	2	2	1.8	1.8	1.6	1.125	1.125	1	1	0.75	0.75	0.75	0.75	0.75	0.75
200	5	5	3	2.8	2.5	2.5	2.5	2	1.5	1.5	1.4	1.25	1.25	1.25	1.125	1	1	1
250	3.5	3.2	3.5	3.5	3.2	3.2	3	2.5	1.8	1.8	1.8	1.6	1.6	1.5	1.5	1.25	1.25	1.25
300	4	4	4.5	4	4	3.5	3.5	3.2	2.25	2.25	2	2	1.8	1.8	1.8	1.6	1.5	1.5
350	5	4.5	5	5	4.5	4.5	4	3.5	2.5	2.5	2.5	2.25	2.25	2	2	1.8	1.8	1.6
500	7	6.25	4	4	3.5	3.5	3.2	5	3.5	3.5	3.5	3.2	3.2	3	3	2.5	2.5	2.5
750	10	10	6.25	6	5.6	5	5	4.5	5.6	5.6	5	5	4.5	4.5	4.5	4	3.5	3.5
1000	12	12	8	8	7	7	6.25	6	4	4	4	3.5	3.5	3.2	3.2	5	5	5
1500	20	15	12	12	10	10	10	9	6.25	6.25	6	5.6	5	5	5	4.5	4	4
2000	20	20	12	12	10	12	12	12	8	8	8	7	7	6.25	6.25	6	5.6	5
3000	30	30	15	15	15	15	15	12	12	12	12	10	10	10	10	9	8	8

(1) Maximum Amp rating for current limiting fuses based on transformer primary voltage and the National Electrical Code.

Table 24 - Primary Fuse Sizing Chart (When primary and secondary protection is used)⁽¹⁾

VA	115V	120V	200V	208V	220V	230V	240V	277V	380V	400V	415V	440V	460V	480V	500V	550V	575V	600V
50	1	1	0.6	0.6	0.5	0.5	0.5	0.4	0.3	0.3	0.3	0.25	0.25	0.25	0.25	0.2	0.2	0.2
75	1.6	1.5	0.75	0.75	0.75	0.75	0.75	0.6	0.4	0.4	0.4	0.4	0.4	0.3	0.3	0.3	0.3	0.3
100	2	2	1.25	1.125	1.125	1	1	0.75	0.6	0.6	0.6	0.5	0.5	0.5	0.5	0.4	0.4	0.4
150	3.2	3	1.8	1.8	1.6	1.6	1.5	1.25	0.75	0.75	0.75	0.75	0.75	0.75	0.75	0.6	0.6	0.6
200	4	4	2.5	2.25	2	2	2	1.8	1.25	1.25	1.125	1.125	1	1	1	0.75	0.75	0.75
250	5	5	3	3	2.8	2.5	2.5	2.25	1.6	1.5	1.5	1.4	1.25	1.25	1.25	1.125	1	1
300	6.25	6.25	3.5	3.5	3.2	3.2	3	2.5	1.8	1.8	1.8	1.6	1.6	1.5	1.5	1.25	1.25	1.25
350	7	7	4	4	3.5	3.5	3.5	3	2.25	2	2	1.8	1.8	1.8	1.6	1.5	1.5	1.4
500	10	10	6.25	6	5.6	5	5	4.5	3.2	3	3	2.8	2.5	2.5	2.5	2.25	2	2
750	15	15	9	9	8	8	7	6.25	4.5	4.5	4.5	4	4	3.5	3.5	3.2	3.2	3
1000	20	20	12	12	10	10	10	9	6.25	6.25	6	5.6	5	5	5	4.5	4	4
1500	30	30	15	15	15	15	15	12	9	9	9	8	8	7	7	6.25	6.25	6.25
2000	40	40	25	20	20	20	20	15	12	12	12	10	10	10	10	9	8	8
3000	45	45	35	35	30	30	30	25	15	15	15	15	15	15	15	12	12	12

(1) Maximum Amp rating for current limiting fuses based on transformer primary voltage and the National Electrical Code.

Table 25 - Secondary Fuse Sizing Chart⁽¹⁾

VA	23V	24V	25V	85V	90V	95V	100V	110V	115V	120V	125V	130V	220V	230V	240V
50	3.5	3.2	3.2	0.75	0.75	0.75	0.75	0.75	0.6	0.6	0.6	0.6	0.3	0.3	0.3
75	5	5	5	1.4	1.25	1.25	1.25	1.125	1	1	1	0.75	0.5	0.5	0.5
100	7	6.25	6.25	1.8	1.8	1.6	1.6	1.5	1.4	1.25	1.25	1.25	0.75	0.6	0.6
150	10	10	10	2.8	2.5	2.5	2.5	2.25	2	2	2	1.8	1.125	1	1
200	12	12	12	3.5	3.5	3.5	3.2	3	2.8	2.5	2.5	2.5	1.5	1.4	1.25
250	15	15	15	4.5	4.5	4	4	3.5	3.5	3.2	3.2	3.2	1.8	1.8	1.6
300	20	20	20	5.6	5	5	5	4.5	4	4	4	3.5	2.25	2	2
350	20	20	20	6.25	6.25	6	5.6	5	5	4.5	4.5	4	2.5	2.5	2.25
500	—	—	—	9	9	8	8	7	7	6.25	6.25	6.25	3.5	3.5	3.2

Table 25 - Secondary Fuse Sizing Chart⁽¹⁾

750	—	—	—	12	12	12	12	10	10	10	10	9	5.6	5	5
1000	—	—	—	15	15	15	15	15	12	12	12	12	7	7	6.25
1500	—	—	—	25	25	25	25	20	20	20	20	15	10	10	10
2000	—	—	—	35	35	35	30	30	25	25	25	25	15	12	12
3000	—	—	—	—	—	—	—	45	40	40	40	35	20	20	20

(1) Maximum Amp rating for current limiting fuses based on the National Electrical Code.

Approximate Dimensions

Dimensions are shown in inches (millimeters). Dimensions are not intended to be used for manufacturing purposes.

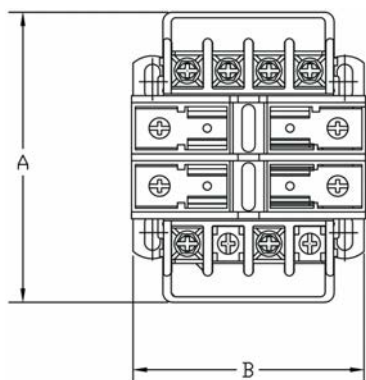

Transformer with 2 Primary Fuse Blocks and 0 or 1 Secondary Fuse Block/Clip (Top View)

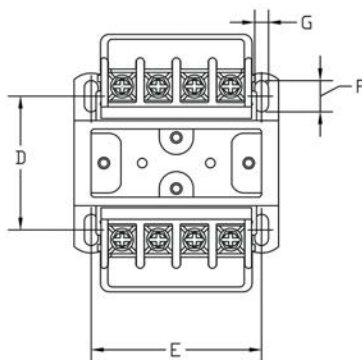

Transformer with 0 Primary Fuse Blocks and 0 or 1 Secondary Fuse Block/Clip (Top View)

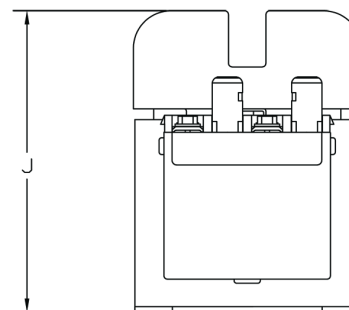

Transformer with 2 Primary Fuse Blocks and 1 Secondary Fuse Block/Clip (Side View)

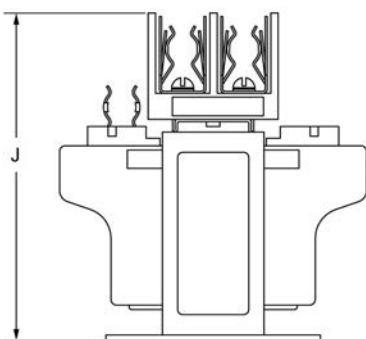

Transformer with 2 Primary Fuse Blocks and 1 Secondary Fuse Block/Clip (Side View)

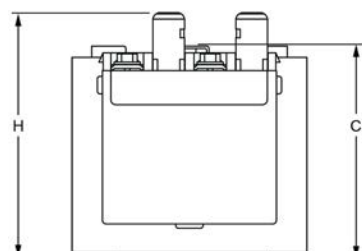

Transformer with 0 Primary Fuse Block and Secondary Fuse Block/Clip (Side View)

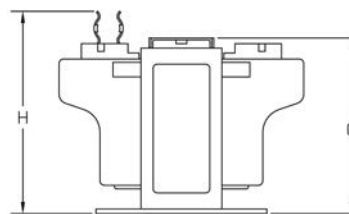

Transformer with 0 Primary Fuse Blocks and 1 Secondary Fuse Block/Clip (Side View)

Table 26 - Approximate Dimensions

VA	Cat. No.	A	B	C	D	E	F	G	H	J	Approx. Shipping Wt. lb (kg)
50	1497B-A1-M13-0-N	3-25/32 (96)	3 (76)	2-23/32 (69)	1-31/32 (50)	2-1/2 (64)	15/32 (12)	1/5 (5)	3-9/64 (80)	4-1/32 (102)	3 (1.4)
	1497B-A1-M16-0-N										
	1497B-A1-M17-0-N										
75	1497B-A2-M13-0-N	4-1/32 (102)	3 (76)	2-23/32 (69)	2-27/64 (61)	2-1/2 (64)	15/32 (12)	1/5 (5)	3-9/64 (80)	4-1/32 (102)	4 (1.8)
	1497B-A3-M11-0-N										
100	1497B-A3-M12-0-N	4 (102)	3-3/8 (86)	3-3/64 (77)	2-27/64 (61)	2-13/16 (71)	15/32 (12)	1/5 (5)	3-15/32 (88)	4-23/64 (110)	5 (2.3)
	1497B-A3-M13-0-N										
	1497B-A3-M14-0-N										
	1497B-A3-M16-0-N										
	1497B-A3-M17-0-N										

Table 26 - Approximate Dimensions (Continued)

150	1497B-A4-M13-0-N	4-1/16 (103)	3-3/4 (95)	3-23/64 (85)	2-13/16 (71)	3-5/16 (80)	15/32 (12)	1/5 (5)	3-49/64 (96)	4-21/32 (118)	6 (2.7)
	1497B-A4-M14-0-N										
	1497B-A4-M16-0-N										
	1497B-A4-M17-0-N										
200	1497B-A5-M11-0-N	4-3/8 (111)	4-1/2 (114)	3-31/32 (101)	2-5/8 (67)	3-3/4 (95)	15/32 (12)	1/5 (5)	4-2/5 (112)	5-9/32 (134)	10 (4.5)
	1497B-A5-M12-0-N										
	1497B-A5-M13-0-N										
250	1497B-A6-M13-0-N	4-3/8 (111)	4-1/2 (114)	3-31/32 (101)	2-53/64 (72)	3-3/4 (95)	15/32 (12)	1/5 (5)	4-2/5 (112)	5-9/32 (134)	10 (4.5)
	1497B-A6-M14-0-N										
	1497B-A6-M16-0-N										
	1497B-A6-M17-0-N										
300	1497B-A7-M11-0-N	4-3/4 (120)	4-1/2 (114)	3-31/32 (101)	3-3/16 (81)	3-3/4 (95)	15/32 (12)	1/5 (5)	4-2/5 (112)	5-9/32 (134)	12 (5.4)
	1497B-A7-M12-0-N										
	1497B-A7-M13-0-N										
500	1497B-A9-M11-0-N	6-7/64 (155)	5-1/4 (133)	4-5/8 (118)	3-7/8 (98)	4-3/8 (111)	1-1/16 (27)	5/16 (8)	—	5-15/16 (151)	18 (8.2)
	1497B-A9-M12-0-N										
	1497B-A9-M14-0-N										
	1497B-A9-M15-0-N										
750	1497B-A10-M12-0-N	7-39/64 (193)	5-1/4 (133)	4-5/8 (118)	5-7/8 (149)	4-3/8 (111)	1-1/16 (27)	5/16 (8)	—	5-15/16 (151)	28 (12.7)
	1497B-A10-M14-0-N										
	1497B-A10-M15-0-N										
1000	1497B-A11-M11-0-N	7-7/64 (181)	6-3/4 (171)	5-55/64 (149)	4-31/32 (126)	6-1/8 (155)	9/10 (23)	5/16 (8)	—	7-3/16 (183)	40 (18.1)
	1497B-A11-M12-0-N										
	1497B-A11-M14-0-N										
	1497B-A11-M15-0-N										41 (18.6)
1500	1497B-A12-M14-0-N	8-7/64 (206)	6-3/4 (171)	5-55/64 (149)	6-1/8 (155)	6-1/8 (155)	7/8 (22)	5/16 (8)	—	7-3/16 (183)	53 (24)
	1497B-A12-M15-0-N										
2000	1497B-A13-M11-0-N	8-7/64 (206)	6-3/4 (171)	5-55/64 (149)	6-1/8 (155)	6-1/8 (155)	7/8 (22)	5/16 (8)	—	7-3/16 (183)	61 (27.7)
	1497B-A13-M12-0-N										
	1497B-A13-M14-0-N										9 (229)
	1497B-A13-M15-0-N										8-7/64 (206)
3000	1497B-A14-M11-0-N	8-9/16 (217)	9 (229)	7-41/64 (194)	5-13/16 (148)	7-1/2 (191)	9/10 (23)	7/16 (11)	—	8-61/64 (227)	78 (35.4)
	1497B-A14-M12-0-N										
	1497B-A14-M14-0-N										
	1497B-A14-M15-0-N										

1497B Transformer Heat Dissipation Specifications

Table 27 - 1497B Estimated Heat Loss

Transformer Size (VA)	Estimated Heat Loss (W)
50	16.2
75	18.6
100	21.0
150	33.7
200	40.1
250	43.4
300	48.4
350	47.9
500	57.1
750	71.2
1000	86.6
1500	104.3
2000	147.3
3000	183.4
5000	241.2

Bulletin 1497D – 1-Phase General Purpose Transformers

Topic	Page
Product Selection	24
Fuse Sizing Charts	26
Approximate Dimensions	27
Accessories	46

Bulletin 1497D General Purpose Transformers are generally used for supplying appliance, lighting, motorized machine, and power loads from electrical distribution systems.

- 0.050...25.0 kVA (60 & 50/60 Hz)
- Indoor/outdoor non-ventilated enclosure
- Single phase
- Resin encapsulated
- Exceeds requirements of the Uniform Building Code (UBC) and California Code Title 24
- Copper windings provided for all transformers rated 2 kVA and below
- Aluminum windings provided for all transformers rated 3 kVA and above
- NEMA Type 3R rated enclosures

Standards Compliance

- CSA C22.2 No. 47 - M90
- UL 1561

Certifications

- cULus Listed (File No. E311296; Guide No. XQNX)
- CSA Certified



Catalog Number Explanation - Bulletin 1497B Control Power Transformers

For a complete list of valid transformer configurations, see Product Selection.

1497D - **A1** **M10** **0** **N**
 a b c d

a		b			c		d	
VA Rating		Primary and Secondary Voltage			Fuse Block Options ⁽¹⁾		Factory Installed Options	
Code	Description [VA]	Code	Primary	Secondary	Code	Block Options	Code	Description
A1	50	M10	240X480V	120/240V (60 Hz)	0	0 Primary, 0 Secondary	2	Two 5% taps below rated primary volts
A2	75	M11	600V	120/240V (60 Hz)			22	2.5% taps: 2 above and 2 below rated primary volts
A3	100	M14	240X480V	120/240V (50/60 Hz)			4	Four 2.5% taps below rated primary volts
A4	150	M20	208V	120/240V (60 Hz)			N	No Taps
A6	250	M21	480V	120/240V (60 Hz)				
A9	500	M22	480V	120/240V (50/60 Hz)				
A10	750	M23	600V	120/240V (50/60 Hz)				
A11	1000	M24	480V	208V (60 Hz)				
A12	1500							
A13	2000							
A14	3000							
A15	5000							
A16	7500							
A17	10000							
A18	15000							
A20	25000							

(1) Transformers rated 350VA and below use secondary fuse clips. Transformers rated 500VA and above use secondary fuse blocks.

208V Primary with No Taps

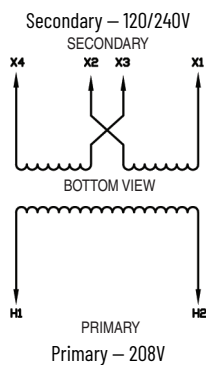

Winding	Voltage Accuracy [V]	Connect	Line
Primary	208	—	H1-H2
Secondary	240	X2-X3	X1-X4
	240/120 ⁽¹⁾	X2-X3	X1-X3-X4
	120	X1X3-X2X4	X1-X4

(1) Three-wire operation.

Continuous kVA	Frequency [Hz]	Temp. Rise [°C (°F)]	Cat. No.
0.050	60	115 (239)	1497D-A1-M20-0-N
0.075			1497D-A2-M20-0-N
0.100			1497D-A3-M20-0-N
0.150			1497D-A4-M20-0-N
3.0			1497D-A14-M20-0-N
5.0			1497D-A15-M20-0-N
7.5			1497D-A16-M20-0-N
10.0			1497D-A17-M20-0-N
15.0			1497D-A18-M20-0-N
25.0			1497D-A20-M20-0-N

240x480V Primary with No Taps

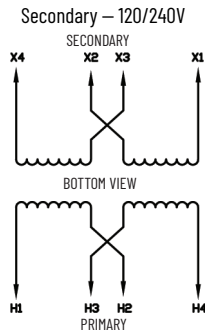

Primary – 240x480V

Winding	Voltage Accuracy [V]	Connect	Line
Primary	480	H2-H3	H1-H4
	240	H1H3- H2H4	H1-H4
Secondary	240	X2-X3	X1-X4
	240/120 ⁽¹⁾	X2-X3	X1-X3-X4
	120	X1X3-X2X4	X1-X4

(1) Three-wire operation.

Continuous kVA	Frequency [Hz]	Temp. Rise [°C (°F)]	Cat. No.
0.050	60	115 (239)	1497D-A1-M10-O-N
	50/60		1497D-A1-M14-O-N
0.075	60		1497D-A2-M10-O-N
	50/60		1497D-A2-M14-O-N
0.100	60		1497D-A3-M10-O-N
	50/60		1497D-A3-M14-O-N
0.150	60		1497D-A4-M10-O-N
	50/60		1497D-A4-M14-O-N
3.0	60		1497D-A14-M10-O-N
	50/60		1497D-A14-M14-O-N
5.0	60		1497D-A15-M10-O-N
	50/60		1497D-A15-M14-O-N
7.5	60		1497D-A16-M10-O-N
	50/60		1497D-A16-M14-O-N
10.0	60		1497D-A17-M10-O-N
	50/60		1497D-A17-M14-O-N
15.0	60		1497D-A18-M10-O-N
	50/60		1497D-A18-M14-O-N
25.0	60		1497D-A20-M10-O-N
	50/60		1497D-A20-M14-O-N

480V Primary with No Taps

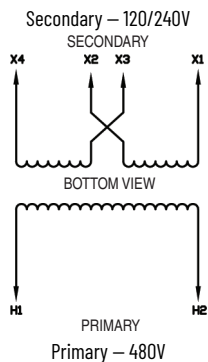

Winding	Voltage Accuracy [V]	Connect	Line
Primary	480	—	H1-H2
Secondary	240	X2-X3	X1-X4
	240/120 ⁽¹⁾	X2-X3	X1-X3-X4
	120	X1X3-X2X4	X1-X4

(1) Three-wire operation.

Continuous kVA	Frequency [Hz]	Temp. Rise [°C (°F)]	Cat. No.
0.050	60	115 (239)	1497D-A1-M21-0-N
0.075			1497D-A2-M21-0-N
0.100			1497D-A3-M21-0-N
0.150			1497D-A4-M21-0-N
0.250			1497D-A6-M21-0-N
3.0			1497D-A14-M21-0-N
5.0	50/60	115 (239)	1497D-A15-M22-0-N
7.5			1497D-A16-M22-0-N
10.0			1497D-A17-M22-0-N
15.0			1497D-A18-M22-0-N
25.0			1497D-A20-M22-0-N

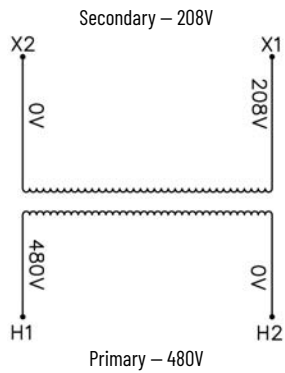

Continuous kVA	Frequency [Hz]	Temp. Rise [°C (°F)]	Cat. No.
0.050	60	115 (239)	1497D-A1-M24-0-N
0.075			1497D-A2-M24-0-N
0.100			1497D-A3-M24-0-N
0.150			1497D-A4-M24-0-N
3.0			1497D-A14-M24-0-N
5.0			1497D-A15-M24-0-N
7.5			1497D-A16-M24-0-N
10.0			1497D-A17-M24-0-N
15.0			1497D-A18-M24-0-N
25.0			1497D-A20-M24-0-N

480V Primary with Two 5% Taps Below Rated Primary Volts

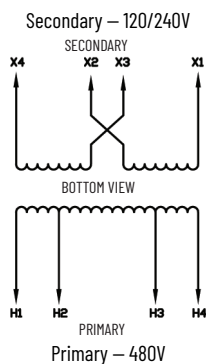

Winding	Voltage Accuracy [V]	Connect	Line
Primary	480	—	H1-H4
	456	—	H2-H4
	432	—	H2-H3
Secondary	240	X2-X3	X1-X4
	240/120 ⁽¹⁾	X2-X3	X1-X3-X4
	120	X1X3-X2X4	X1-X4

(1) Three-wire operation.

Continuous kVA	Frequency [Hz]	Temp. Rise [°C (°F)]	Tap Quantity	Cat. No.
0.250	50/60	115 (239)	(2) 5% FCBN	1497D-A6-M22-0-2
3.0	60			1497D-A14-M21-0-2
	50/60			1497D-A14-M22-0-2
5.0	60			1497D-A15-M21-0-2
7.5				1497D-A16-M21-0-2
10.0				1497D-A17-M21-0-2
15.0				1497D-A18-M21-0-2
25.0				1497D-A20-M21-0-2

480V Primary with Two 2.5% Taps Above & Two 2.5% Below Rated Primary Volts

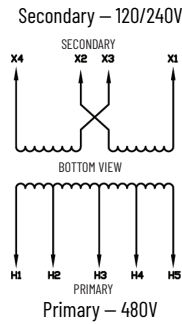

Winding	Voltage Accuracy [V]	Connect	Line
Primary	504	—	H1-H5
	492	—	H1-H4
	480	—	H1-H3
	468	—	H2-H4
	456	—	H2-H3
Secondary	240	X2-X3	X1-X4
	240/120 ⁽¹⁾	X2-X3	X1-X3-X4
	120	X1X3-X2X4	X1-X4

(1) Three-wire operation.

Continuous kVA	Frequency [Hz]	Temp. Rise [°C (°F)]	Tap Quantity	Cat. No.
3.0	60	115 (239)	(2) 2.5% FCAN (2) 2.5% FCBN	1497D-A14-M21-0-22
5.0				1497D-A15-M21-0-22
7.5				1497D-A16-M21-0-22
10.0				1497D-A17-M21-0-22
15.0				1497D-A18-M21-0-22
25.0				1497D-A20-M21-0-22

600V Primary with No Taps

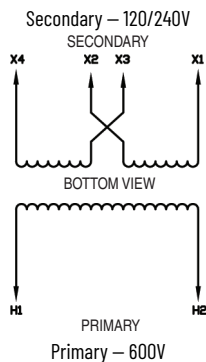

Winding	Voltage Accuracy [V]	Connect	Line
Primary	600	—	H1-H2
Secondary	240	X2-X3	X1-X4
	240/120 ⁽¹⁾	X2-X3	X1-X3-X4
	120	X1X3-X2X4	X1-X4

(1) Three-wire operation.

Continuous kVA	Frequency [Hz]	Temp. Rise [°C (°F)]	Cat. No.
0.050	60	115 (239)	1497D-A1-M11-0-N
0.075			1497D-A2-M11-0-N
0.100	60		1497D-A3-M11-0-N
	50/60		1497D-A3-M23-0-N
0.150	60		1497D-A4-M11-0-N
3.0			1497D-A14-M11-0-N
5.0			1497D-A15-M11-0-N
7.5			1497D-A16-M11-0-N
10.0			1497D-A17-M11-0-N
15.0			1497D-A18-M11-0-N
25.0			1497D-A20-M11-0-N

600V Primary with Two 5% Taps Below Rated Primary Volts

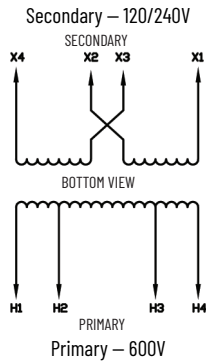

Winding	Voltage Accuracy [V]	Connect	Line
Primary	600	—	H1-H2
	570	—	H1-H3
	540	—	H2-H3
Secondary	240	X2-X3	X1-X4
	240/120 ⁽¹⁾	X2-X3	X1-X3-X4
	120	X1X3-X2X4	X1-X4

(1) Three-wire operation.

Continuous kVA	Frequency [Hz]	Temp. Rise [°C (°F)]	Tap Quantity	Cat. No.
3.0	60	115 (239)	(2) 5% FCBN	1497D-A14-M11-0-2
	50/60			1497D-A14-M23-0-2
5.0	60			1497D-A15-M11-0-2
7.5				1497D-A16-M11-0-2
10.0				1497D-A17-M11-0-2

600V Primary with Four 2.5% Taps Below Rated Primary Volts

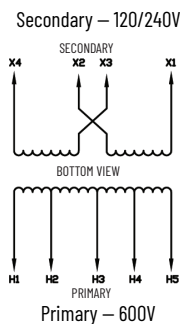

Winding	Voltage Accuracy [V]	Connect	Line
Primary	600	—	H1-H5
	585	—	H1-H4
	570	—	H1-H3
	555	—	H2-H4
	540	—	H2-H3
Secondary	240	X2-X3	X1-X4
	240/120 ⁽¹⁾	X2-X3	X1-X3-X4
	120	X1X3-X2X4	X1-X4

(1) Three-wire operation.

Continuous kVA	Frequency [Hz]	Temp. Rise [°C (°F)]	Tap Quantity	Cat. No.
15.0	60	115 (239)	(2) 2.5% FCBN	1497D-A18-M11-0-4
25.0				1497D-A20-M11-0-4

Approximate Dimensions

Dimensions are shown in inches (millimeters). Dimensions are not intended to be used for manufacturing purposes.

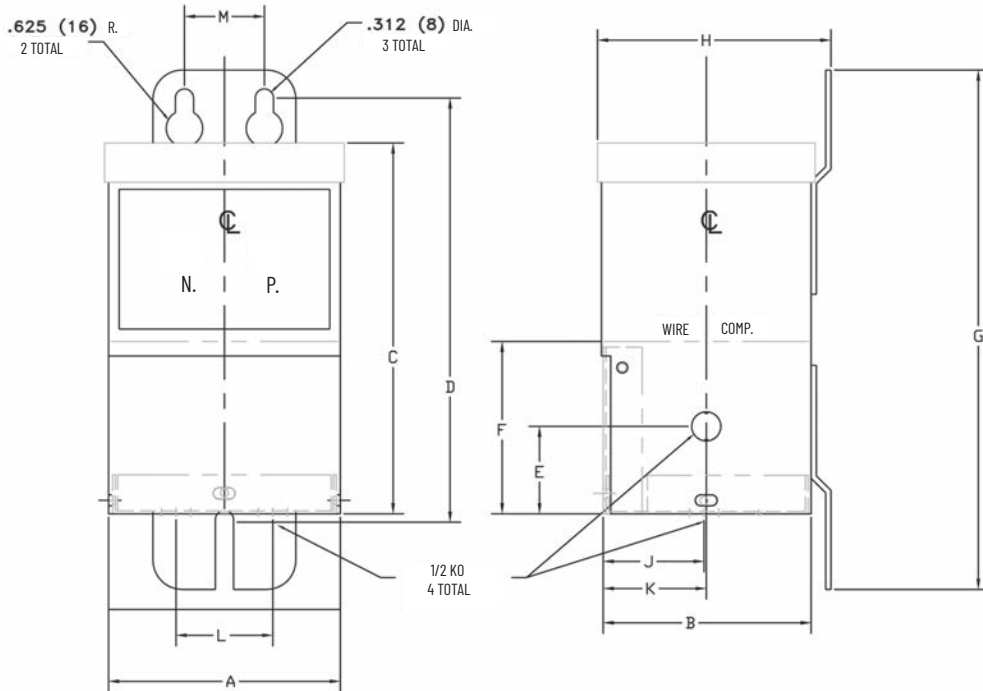

VA (Code)	Primary and Secondary Voltage Code	A	B	C	D	E	F	G	H	J	K	L	M	Approx. Shipping Weight lb(kg) Copper
50 (A1)	M10, M20,	3-31/32	3-9/16	6-23/64	7-17/64	1-1/2	2-61/64	8-29/32	4	1-47/64	1-49/64	1-2/3	1-3/8	8
	M21, M24	(101)	(90)	(162)	(185)	(38)	(75)	(226)	(102)	(44)	(45)	(42)	(35)	(4)
	M14	3-31/32 (101)	3-9/16 (90)	6-23/64 (162)	7-3/8 (187)	1-1/2 (38)	2-61/64 (75)	8-29/32 (226)	4 (102)	1-47/64 (44)	1-49/64 (45)	1-2/3 (42)	1-3/8 (35)	8 (4)
	M11	3-31/32 (101)	3-9/16 (90)	6-23/64 (162)	7-17/64 (185)	1-1/2 (38)	2-61/64 (75)	8-29/32 (226)	4 (102)	1-47/64 (44)	1-49/64 (45)	1-2/3 (42)	1-3/8 (35)	8 (4)
75 (A2)	M10, M11, M14, M20, M21, M24	3-31/32 (101)	3-9/16 (90)	6-23/64 (162)	7-17/64 (185)	1-1/2 (38)	2-61/64 (75)	8-29/32 (226)	4 (102)	1-47/64 (44)	1-49/64 (45)	1-2/3 (42)	1-3/8 (35)	8 (4)
100 (A3)	M10, M11, M14, M20, M21, M23, M24	3-31/32 (101)	3-9/16 (90)	6-23/64 (162)	7-17/64 (185)	1-1/2(38)	2-61/64 (75)	8-29/32 (226)	4 (102)	1-47/64 (44)	1-49/64 (45)	1-2/3 (42)	1-3/8 (35)	8 (4)
150 (A4)	M10, M11, M20, M21, M24	3-31/32 (101)	3-9/16 (90)	6-23/64 (162)	7-17/64 (185)	1-1/2 (38)	2-61/64 (75)	8-29/32 (226)	4 (102)	1-47/64 (44)	1-49/64 (45)	1-2/3 (42)	1-3/8 (35)	8 (4)

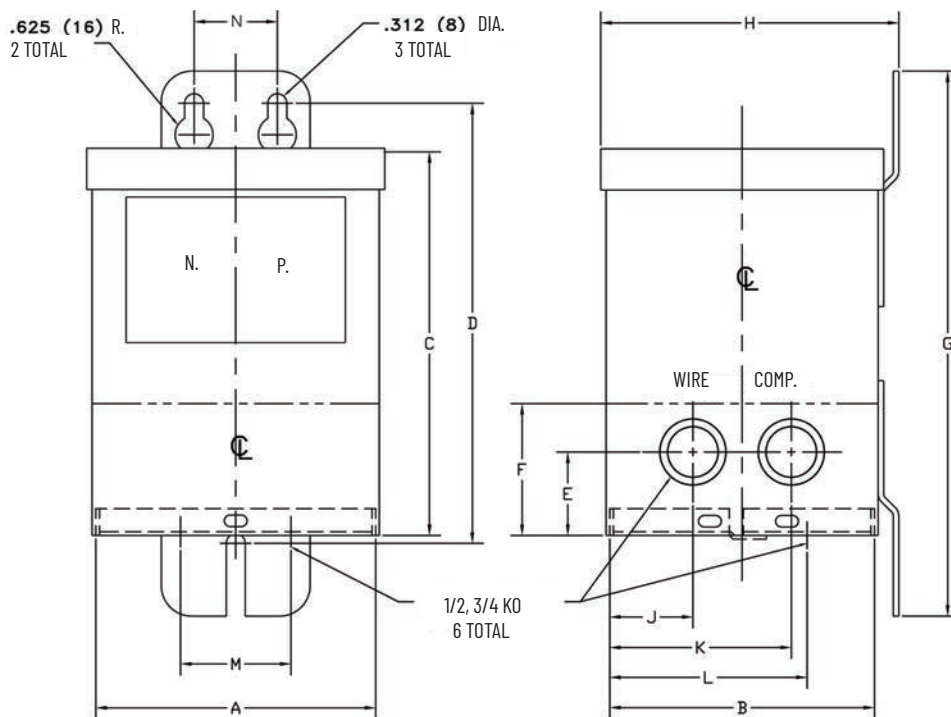

VA (Code)	Primary and Secondary Voltage	A	B	C	D	E	F	G	H	J	K	L	M	N	Approx. Shipping Weight lb (kg) Copper
150 (A4)	M14	4-39/64 (117)	3-33/64 (89)	6-5/16 (160)	7-1/4 (184)	1-3/8 (35)	2-5/32 (55)	8-31/32 (228)	4-1/6 (103)	15/16 (24)	2-9/16 (65)	2-1/2 (64)	1-53/64 (46)	1-3/8 (35)	15 (6)
250 (A6)	M10, M11, M14, M20, M21, M22, M23, M24	4-39/64 (117)	3-33/64 (89)	6-5/16 (160)	7-1/4 (184)	1-3/8 (35)	2-5/32 (55)	8-31/32 (228)	4-1/16 (103)	15/16 (24)	2-9/16 (65)	2-33/64 (64)	1-53/64 (46)	1-3/8 (35)	15 (6)
500 (A9)	M10, M11, M14, M20, M21, M23, M24	4-39/64 (117)	4-23/64 (111)	6-5/16 (160)	7-1/4 (184)	1-3/8 (35)	2-5/32 (55)	8-31/32 (228)	4-29/32 (125)	1-3/8 (35)	3 (76)	3-3/8 (86)	1-53/64 (46)	1-3/8 (35)	16 (7)

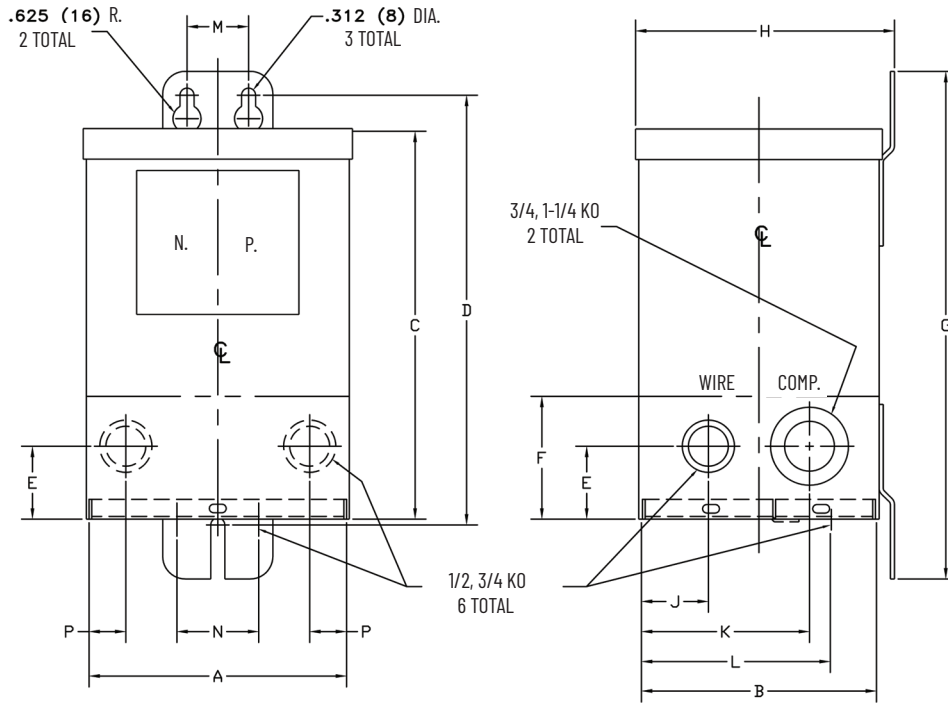

VA (Code)	Primary and Secondary Voltage	A	B	C	D	E	F	G	H	J	K	L	M	N	P	Approx Shipping Wt. lb (kg) Copper
500 (A9)	M22, M23	5-47/64 (146)	5-15/64 (133)	8-5/8 (219)	9-35/64 (243)	1-5/8 (41)	2-47/64 (69)	11-9/32 (287)	5-3/4 (146)	1-1/2 (38)	3-3/4 (95)	4-1/4 (108)	1-3/8 (35)	1-53/64 (46)	7/8 (22)	24 (11)
750 (A10)	M11, M21	5-47/64 (146)	5-15/64 (133)	8-5/8 (219)	9-35/64 (243)	1-5/8 (41)	2-47/64 (69)	11-9/32 (287)	5-3/4 (146)	1-1/2 (38)	3-3/4 (95)	4-1/4 (108)	1-3/8 (35)	1-53/64 (46)	7/8 (22)	24 (11)
750 (A10)	M10, M14, M20, M22, M23, M24	5-47/64 (146)	5-15/64 (133)	8-5/8 (219)	9-35/64 (243)	1-5/8 (41)	2-47/64 (69)	11-9/32 (287)	5-3/4 (146)	1-1/2 (38)	3-3/4 (95)	4-1/4 (108)	1-3/8 (35)	1-53/64 (46)	7/8 (22)	36 (16)
1000 (A11) ⁽¹⁾	M10, M11, M14, M20, M21, M24	5-47/64 (146)	5-15/64 (133)	8-5/8 (219)	9-35/64 (243)	1-5/8 (41)	2-47/64 (69)	11-9/32 (287)	5-3/4 (146)	1-1/2 (38)	3-3/4 (95)	4-1/4 (108)	1-3/8 (35)	1-53/64 (46)	7/8 (22)	36 (16)
1000 (A11)	M22, M23	6-1/10 (155)	6 (152)	10-3/4 (273)	11-49/64 (299)	1-3/4 (44)	3 (76)	13-13/32 (341)	6-33/64 (166)	1-7/8 (48)	4-1/8 (105)	4-53/64 (122)	1-3/8 (35)	1-53/64 (46)	1 (25)	50 (23)
1500 (A12)	M10, M11, M14, M20, M21, M22, M24	6-1/10 (155)	6 (152)	10-3/4 (273)	11-49/64 (299)	1-3/4 (44)	3 (76)	13-13/32 (341)	6-33/64 (166)	1-7/8 (48)	4-1/8 (105)	4-53/64 (122)	1-3/8 (35)	1-53/64 (46)	1 (25)	50 (23)
2000 (A13)	M10, M11, M14, M20, M21, M24	6-1/10 (155)	6 (152)	10-3/4 (273)	11-49/64 (299)	1-3/4 (44)	3 (76)	13-13/32 (341)	6-33/64 (166)	1-7/8 (48)	4-1/8 (105)	4-53/64 (122)	1-3/8 (35)	1-53/64 (46)	1 (25)	50 (23)

(1) 1 in. and 1.5 in. knock-outs (two total).

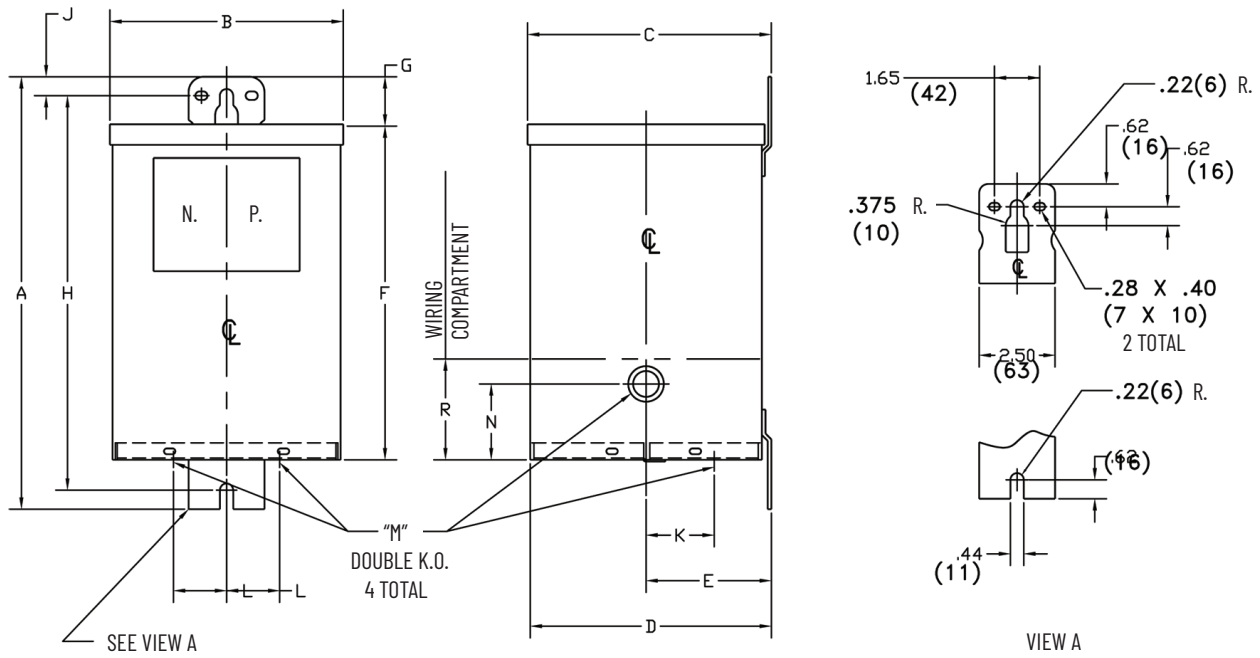

VA (Code)	Primary and Secondary Voltage	A	B	C	D	E	F	G	H	J	K	L	M	N	R	Approx Shipping Wt. lb (kg)
2000 (A13) ⁽¹⁾	M22	14-1/4 (362)	7-11/16 (195)	8 (203)	7-15/16 (202)	4-1/6 (103)	11-1/16 (281)	1-5/8 (41)	13 (330)	5/8 (16)	2-1/4 (57)	1-3/4 (44)	1/2, 3/4 (13, 19)	2-1/2 (64)	3-21/64 (84)	69 (31)
3000 (A14)	M10, M11, M20, M21, M24	14-1/4 (362)	7-11/16 (195)	8 (203)	7-15/16 (202)	4-1/6 (103)	11-1/16 (281)	1-5/8 (41)	13 (330)	5/8 (16)	2-1/4 (57)	1-3/4 (44)	1/2, 3/4 (13, 19)	2-1/2 (64)	3-21/64 (84)	65 (30)

(1) Copper aluminum.

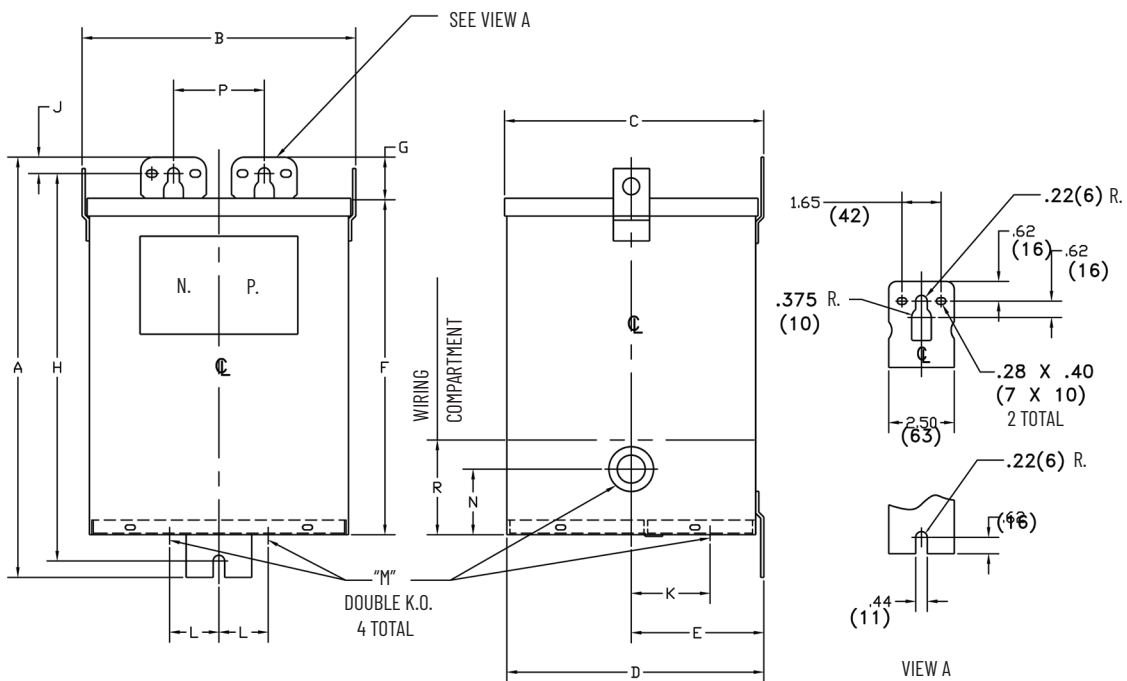

VA (Code)	Primary and Secondary Voltage	A	B	C	D	E	F	G	H	J	K	L	M	N	P	Q	R	Approx Shipping Wt. lb (kg) Aluminum
3000 (A14)	M14, M22, M23	16 (406)	10-3/8 (264)	9-5/7/64 (251)	9-4/5 (249)	5-1/6 (129)	12-53/64 (326)	1-5/8 (41)	14-3/4 (375)	5/8 (16)	3 (76)	1-7/8 (48)	3/4, 1-1/4 (19, 32)	3/4, 1-1/4 (19, 32)	3-15/32 (88)	-	3-39/64 (92)	113 (51)
5000 (A15)	M10, M11, M20, M21, M24	16 (406)	10-3/8 (264)	9-5/7/64 (251)	9-4/5 (249)	5-1/6 (129)	12-53/64 (326)	1-5/8 (41)	14-3/4 (375)	5/8 (16)	3 (76)	1-7/8 (48)	3/4, 1-1/4 (19, 32)	3/4, 1-1/4 (19, 32)	3-15/32 (88)	-	3-39/64 (92)	113 (51)
5000 (A15)	M14, M22	16 (406)	10-3/8 (264)	9-5/7/64 (251)	9-4/5 (249)	5-1/6 (129)	12-53/64 (326)	1-5/8 (41)	14-3/4 (375)	5/8 (16)	3 (76)	1-7/8 (48)	3/4, 1-1/4 (19, 32)	2-1/2 (64)	3-15/32 (88)	-	3-39/64 (92)	123 (55)
7500 (A16)	M10, M11, M20, M21, M24	16 (406)	10-3/8 (264)	9-5/7/64 (251)	9-4/5 (249)	5-1/6 (129)	12-53/64 (326)	1-5/8 (41)	14-3/4 (375)	5/8 (16)	3 (76)	1-7/8 (48)	3/4, 1-1/4 (19, 32)	2-1/2 (64)	3-15/32 (88)	-	3-39/64 (92)	123 (55)
7500 (A16)	M14, M22	19 (483)	13-3/8 (340)	10-33/64 (267)	10-15/32 (266)	5-7/6 (138)	15-53/64 (402)	1-5/8 (41)	17-3/4 (451)	5/8 (16)	3-3/8 (86)	1-7/8 (48)	3/4, 1-1/4 (19, 32)	2-1/2 (64)	3-15/32 (88)	1, 1-1/2 (25, 38)	3-3/4 (95)	193 (87)
10000 (A17)	M10, M11, M20, M21, M24	19 (483)	13-3/8 (340)	10-33/64 (267)	10-15/32 (266)	5-7/6 (138)	15-53/64 (402)	1-5/8 (41)	17-3/4 (451)	5/8 (16)	3-3/8 (86)	1-7/8 (48)	3/4, 1-1/4 (19, 32)	2-1/2 (64)	3-15/32 (88)	1, 1-1/2 (25, 38)	3-3/4 (95)	193 (87)
10000 (A17)	M14, M22	19 (483)	13-3/8 (340)	10-33/64 (267)	10-15/32 (266)	5-7/6 (138)	15-53/64 (402)	1-5/8 (41)	17-3/4 (451)	5/8 (16)	3-3/8 (86)	1-7/8 (48)	3/4, 1-1/4 (19, 32)	2-1/2 (64)	3-15/32 (88)	1, 1-1/2 (25, 38)	3-3/4 (95)	216 (98)
15000 (A18)	M10, M11, M20, M21, M22	19 (483)	13-3/8 (340)	10-33/64 (267)	10-15/32 (266)	5-7/6 (138)	15-53/64 (402)	1-5/8 (41)	17-3/4 (451)	5/8 (16)	3-3/8 (86)	1-7/8 (48)	3/4, 1-1/4 (19, 32)	2-1/2 (64)	3-15/32 (88)	1, 1-1/2 (25, 38)	3-3/4 (95)	216 (98)

Cat. No. 1491-R150
Fuse Cover without Fuse

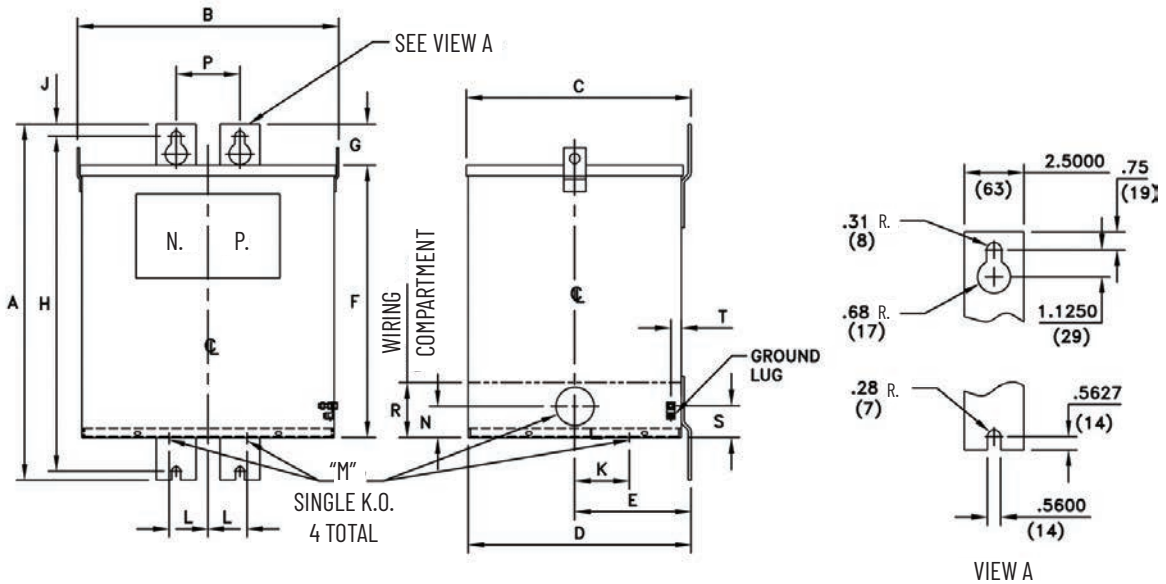

VA (Code)	Primary and Secondary Voltage	A	B	C	D	E	F	G	H	J
15000 (A18)	M14, M22	23-5/16 (592)	16-11/32 (415)	14- 1/8 (359)	14-1/16 (357)	7-25/64 (188)	18-1/16 (459)	2-19/32 (66)	22 (558)	3/4 (19)
25000 (A20)	M10, M11, M14, M20, M21, M22, M24	23-5/16 (592)	16-11/32 (415)	14- 1/8 (359)	14-1/16 (357)	7-25/64 (188)	18-1/16 (459)	2-19/32 (66)	22 (558)	3/4 (19)

VA (Code)	Primary and Secondary Voltage	K	L	M	N	P	R	S	T	Approx Shipping Wt. lb (kg) Aluminum
15000 (A18)	M14, M22	3-7/16 (87)	2-7/16 (62)	2 (51)	2-7/16 (62)	4 (102)	4-7/16 (113)	2 (51)	21/32 (17)	375 (170)
25000 (A20)	M10, M11, M14, M20, M21, M22, M24	3-7/16 (87)	2-7/16 (62)	2 (51)	2-7/16 (62)	4 (102)	4-7/16 (113)	2 (51)	21/32 (17)	375 (170)

General Purpose Transformers Accessories

These control circuit fusing kits are intended to be used for control circuit transformer protection and protection of control circuits capable of delivering no more than 200,000 RMS symmetrical amps, 600V maximum.

Fuse Block Kits - For Use when Fuse Block is Not Integrated with the Transformer



Cat. No. 1491-R165
1-Pole Fuse Block



Cat. No. 1491-R167
2-Pole Fuse Block



Cat. No. 1491-R171
3-Pole Fuse Block



Cat. No. 1491-R169
3-Pole Fuse Block



Cat. No. 1491-R150
Fuse Cover without Fuse

Table 28 - Control Circuit Fusing Kits

Description ⁽¹⁾	Cat. No.
Fuse cover – per pole	1491-R150
One-pole kit – panel-mounted (midget fuse) ⁽²⁾	1491-R165
Two-pole kit – panel-mounted (two Class CC fuses) ⁽²⁾	1491-R162
Two-pole kit – panel-mounted (two midget fuses) ⁽²⁾	1491-R167
Three-pole kit – panel-mounted (one midget fuse/two Class CC fuses) ⁽²⁾	1491-R169
Three-pole kit – panel-mounted (three Class CC fuses) ⁽²⁾	1491-R171
Single-pole kit – Bulletin 500 line controller mounted (Class CC fuses) ⁽³⁾	599-FR04

(1) For control circuit transformers with a 350VA or larger rating, it is recommended that Bussmann Type FNQ-R, Ferraz-Shawmut Type ATDR, Littelfuse Type KLDR time delay fuses, or equivalent be used for primary fusing.

(2) These kits use only Class CC or Midget fuses (rated 0.5...30 A) such as those offered by Bussmann KTK-R, Ferraz-Shawmut ATM R, or Littelfuse KLK.

(3) Cat. No. 599-FR04 is rated for 6 A fuse maximum. Controller mounting applies to size 0...5 devices only.

Approximate Dimensions

Dimensions are shown in inches (millimeters). Dimensions are not intended to be used for manufacturing purposes. Electrical clearance required to top of fuse block.

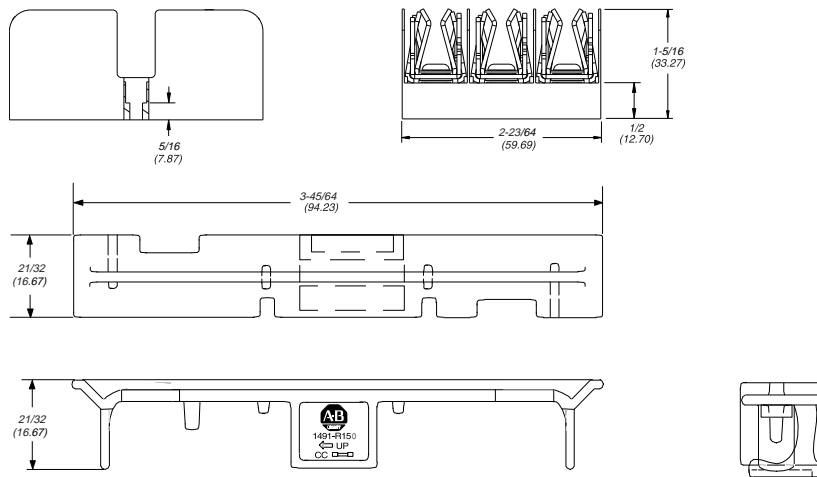
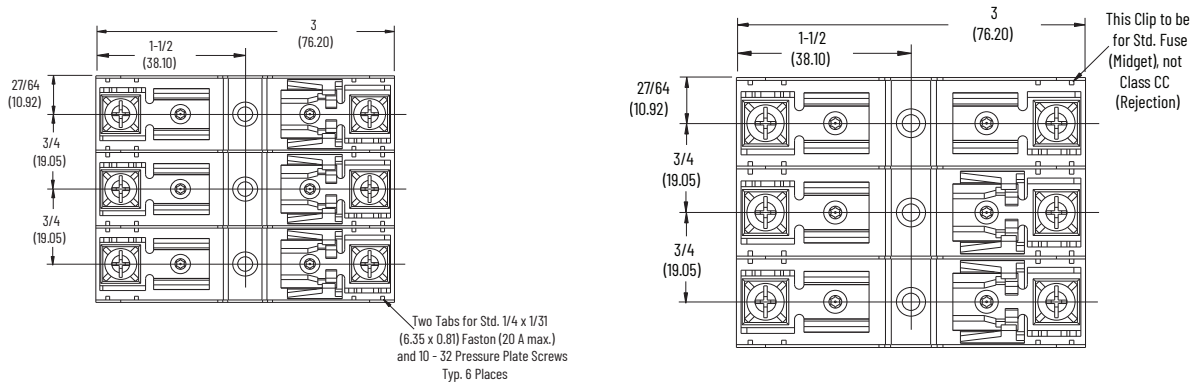
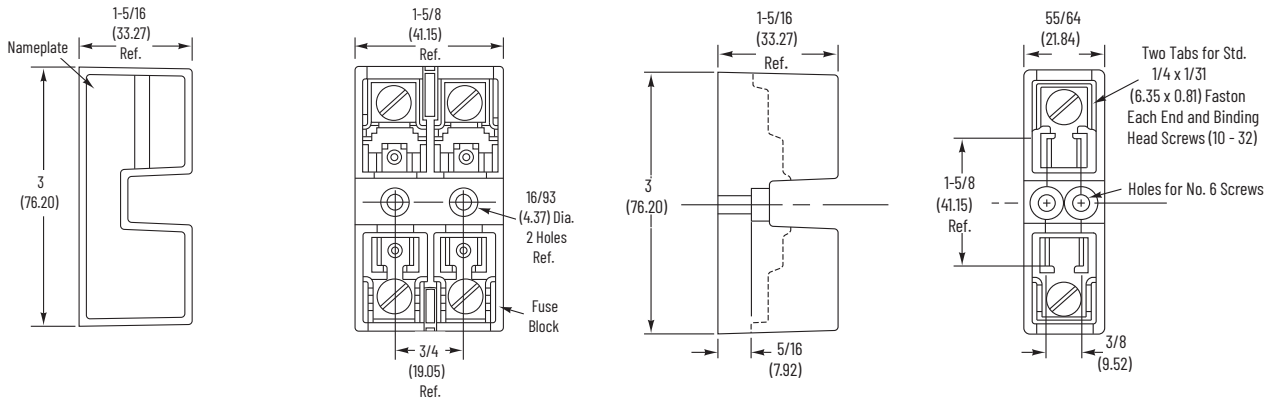

Notes:

Additional Resources

These documents contain additional information concerning related products from Rockwell Automation. You can view or download publications at rok.auto/literature.

Resource	Description
Industrial Automation Wiring and Grounding Guidelines, publication 1770-4.1	Provides general guidelines for installing a Rockwell Automation industrial system.
EtherNet/IP Network Devices User Manual Publication ENET-UM006	Describes how to configure and use EtherNet/IP devices to communicate on the EtherNet/IP network.
Ethernet Reference Manual Publication ENET-RM002	Describes basic Ethernet concepts, infrastructure components, and infrastructure features.
System Security Design Guidelines Reference Manual Publication SECURE-RM001	Provides guidance on how to conduct security assessments, implement Rockwell Automation products in a secure system, harden the control system, manage user access, and dispose of equipment.
UL Standards Listing for Industrial Control Products, publication CMPNTS-SR002	Assists original equipment manufacturers (OEMs) with construction of panels, to help ensure that they conform to the requirements of Underwriters Laboratories.
American Standards, Configurations, and Ratings: Introduction to Motor Circuit Design, publication IC-AT001	Provides an overview of American motor circuit design based on methods that are outlined in the NEC.
Industrial Components Preventive Maintenance, Enclosures, and Contact Ratings Specifications, publication IC-TD002	Provides a quick reference tool for Allen-Bradley industrial automation controls and assemblies.
Safety Guidelines for the Application, Installation, and Maintenance of Solid-state Control, publication SGI-1.1	Designed to harmonize with NEMA Standards Publication No. ICS 1.1-1987 and provides general guidelines for the application, installation, and maintenance of solid-state control in the form of individual devices or packaged assemblies incorporating solid-state components.
Industrial Automation Wiring and Grounding Guidelines, publication 1770-4.1	Provides general guidelines for installing a Rockwell Automation industrial system.
Product Certifications website, rok.auto/certifications .	Provides declarations of conformity, certificates, and other certification details.

Rockwell Automation Support

Use these resources to access support information.

Technical Support Center	Find help with how-to videos, FAQs, chat, user forums, Knowledgebase, and product notification updates.	rok.auto/support
Local Technical Support Phone Numbers	Locate the telephone number for your country.	rok.auto/phonesupport
Technical Documentation Center	Quickly access and download technical specifications, installation instructions, and user manuals.	rok.auto/techdocs
Literature Library	Find installation instructions, manuals, brochures, and technical data publications.	rok.auto/literature
Product Compatibility and Download Center (PCDC)	Download firmware, associated files (such as AOP, EDS, and DTM), and access product release notes.	rok.auto/pcdc

Documentation Feedback

Your comments help us serve your documentation needs better. If you have any suggestions on how to improve our content, complete the form at rok.auto/docfeedback.





Allen-Bradley, expanding human possibility, and Rockwell Automation are trademarks of Rockwell Automation, Inc.

EtherNet/IP is a trademark of ODVA, Inc.

Trademarks not belonging to Rockwell Automation are property of their respective companies.

Rockwell Automation maintains current product environmental compliance information on its website at rok.auto/pec.

Rockwell Otomasyon Ticaret A.Ş. Kar Plaza İş Merkezi E Blok Kat:6 34752, İçerenköy, İstanbul, Tel: +90 (216) 5698400 EEE Yönetmeliğine Uygundur

Connect with us.    

rockwellautomation.com ————— **expanding human possibility®**

AMERICAS: Rockwell Automation, 1201 South Second Street, Milwaukee, WI 53204-2496 USA, Tel: (1) 414.382.2000

EUROPE/MIDDLE EAST/AFRICA: Rockwell Automation NV, Pegasus Park, De Kleetlaan 12a, 1831 Diegem, Belgium, Tel: (32) 2663 0600

ASIA PACIFIC: Rockwell Automation SEA Pte Ltd, 2 Corporation Road, #04-05, Main Lobby, Corporation Place, Singapore 618494, Tel: (65) 6510 6608

UNITED KINGDOM: Rockwell Automation Ltd., Pitfield, Kiln Farm, Milton Keynes, MK11 3DR, United Kingdom, Tel: (44)(1908) 838-800

Publication 1497-TD001G-EN-P - January 2026

Supersedes Publication 1497-TD001F-EN-P - September 2024

Copyright © 2026 Rockwell Automation, Inc. All rights reserved. Printed in the U.S.A.