

NOTES: FINISH - TYPE 304 STAINLESS STEEL
 NOT UL LISTED
 SUITABLE FOR USE AS SERVICE EQUIPMENT
 SHORT CIRCUIT CURRENT RATING:
 10,000 AMPERES WHEN PROTECTED BY CLASS H OR K FUSES.
 ▲ SERVICE GROUND NOT SUPPLIED. ORDER SEPARATELY WHEN REQUIRED.

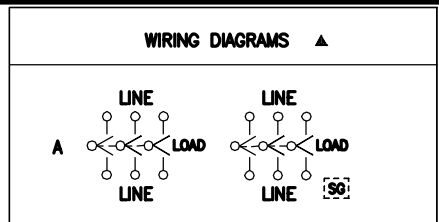

TERMINAL LUGS			
AMPERES	MAX WIRE	MIN WIRE	TYPE
200	300 KCMIL	#6 AWG	AL/CU

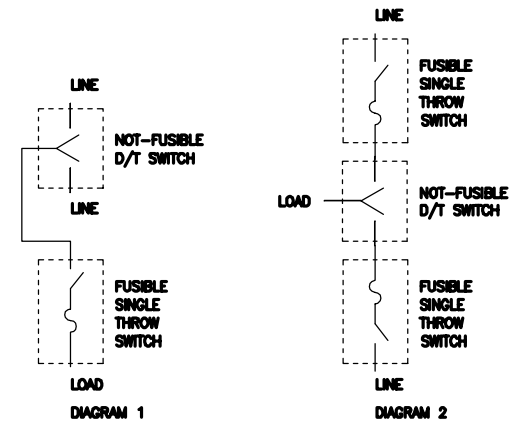

DIAGRAM 1 AND 2 ILLUSTRATE METHODS OF APPLYING FUSES TO DOUBLE THROW SWITCHES WHEN REQUIRED.

DUAL DIMENSIONS: INCHES
 MILLIMETERS

CATALOG NUMBER	VOLTAGE RATINGS	WIRING DIAG	HORSEPOWER RATINGS
			480VAC
			3 Ø
82344DS	480VAC;250VDC	A	15

DOUBLE THROW SAFETY SWITCHES
 200 AMPERE
 ENCLOSURE - NEMA TYPE 4, 4X, 5, 12
 STAINLESS STEEL

SQUARE D COMPANY
 Schneider Electric

DWG# 2199
 NO.