



Catalog Number: 6612-GSC1  
Item Description: N1 SCREW CVR GUTTER  
UPC Code: 784572107724

Brand Name: Milbank  
Type: Lay In Wireway  
Application: Wireway  
Standard: UL Listed, Type 1  
Cover Type: Screw Cover  
Enclosure: Indoor Enclosure  
Nominal Cross Section: 6x6  
Straight Section Length: 12  
Material: Steel with Powder Coat Finish  
Finish: ANSI 61 Gray  
Knockouts: True



*Utility requirements may vary. Always consult the serving utility for their requirements prior to ordering or installing this equipment. This product must always be installed by a licensed electrician. Installation of this equipment may require local electrical inspector approval.*

CATALOG#	LABEL#
6612-GSC1(-)	1002943
RC-6612-GSC1(-)	1125051
SPS-661(-)	1132575

NO.	QTY.	PART NO.	DESCRIPTION
1	1	(SEE CHART)	BACK
2	1	(SEE CHART)	PLATE/COVER
3	1	(SEE CHART)	UL LABEL, WIREWAY
4	1	1002942	LABEL, RATING
5	4	1001290	SCREW, 10-32 X 5/16
6	2	1002880	BAG ASSY (NOT SHOWN)

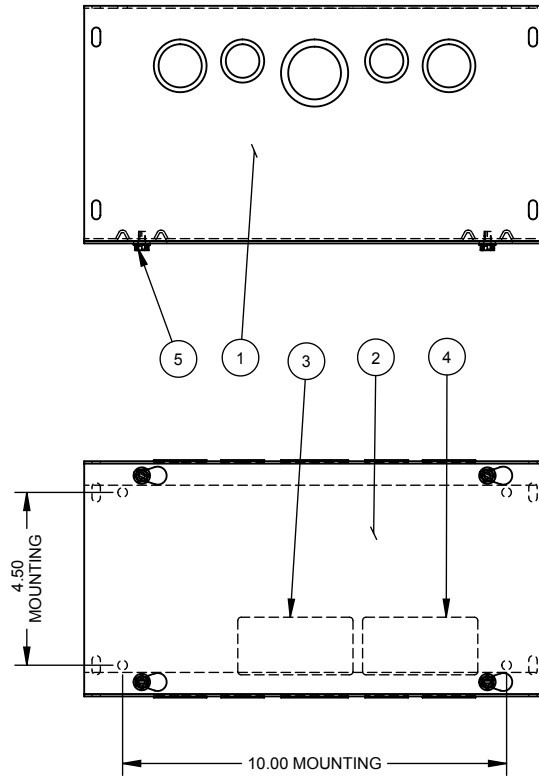

SUFFIX	BACK #	COVER #
-SU	1001359	1003311
-SUC	1128951	1128935
-SO	1128952	1092841
-SUNK	1010573	1003311
-NK	1010567	1092841
-SUNKC	1128953	1128935

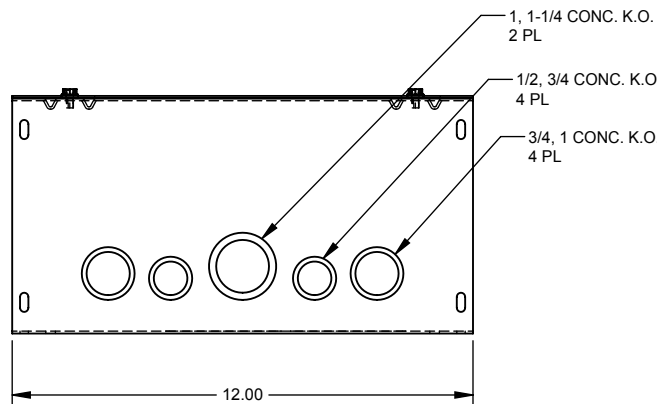
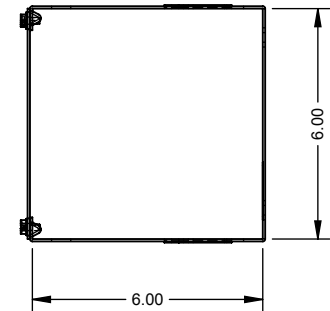

NOTE:  
1. PLACE BAG ASS'Y INSIDE ENCLOSURE. (NOT SHOWN)

SUFFIX	FINISH
NONE	PAINTED
-NP	NOT PAINTED

NEMA DWG.: #247

Material:	16 GA. - SEE CHART		General Offices: Kansas City, MO	
Finish:	SEE CHART		Title:	SCREW COVER WIREWAY 6 x 6 x 12, TYPE 1 NEMA ENCLOSURE
Tolerances: Unless Specified Otherwise X.X ±.1 X.XX ±.03 X.XXX ±.015 X° ±2°			Catalog No.:	(SEE CHART)
		Projection	Customer:	MILBANK STANDARD
Scale:	NTS	Checked By:	Drawing No.:	<b>1000874</b>
Drawn By:	DY	Approved By:	Date:	05/23/02 Sheet 1 of 1

REV	DATE	DESCRIPTION	BY	CHKD	DATE	QTY	REVISION
B1	8-14-06	ADDED NOTE #2. ECO #15069	CMW	C1	5/1/08		ADDED CHART & REMOVED NOTE #2(ECO.17139)
C	8-28-07	ADDED BACK & COVER CHART ECO. 15946	DL	D	8/24/11		1002880 (2) WAS (4) (ECO #21227)