



Catalog Number: 6618-GSC1
Item Description: N1 SCREW CVR GUTTER
UPC Code: 784572107809

Brand Name: Milbank
Type: Lay In Wireway
Application: Wireway
Standard: UL Listed, Type 1
Cover Type: Screw Cover
Enclosure: Indoor Enclosure
Nominal Cross Section: 6x6
Straight Section Length: 18
Material: Steel with Powder Coat Finish
Finish: ANSI 61 Gray
Knockouts: True



Utility requirements may vary. Always consult the serving utility for their requirements prior to ordering or installing this equipment. This product must always be installed by a licensed electrician. Installation of this equipment may require local electrical inspector approval.

PREFIX	LABEL NO.
NONE	1002943
RC-	1125051

NO.	QTY.	PART NO.	DESCRIPTION
1	1	(SEE CHART)	BACK
2	1	(SEE CHART)	PLATE/COVER
3	1	(SEE CHART)	UL LABEL, WIREWAY
4	1	1002942	LABEL, RATING
5	4	1001290	SCREW, 10-32 X 5/16
6	2	1002880	BAG ASSY (NOT SHOWN)

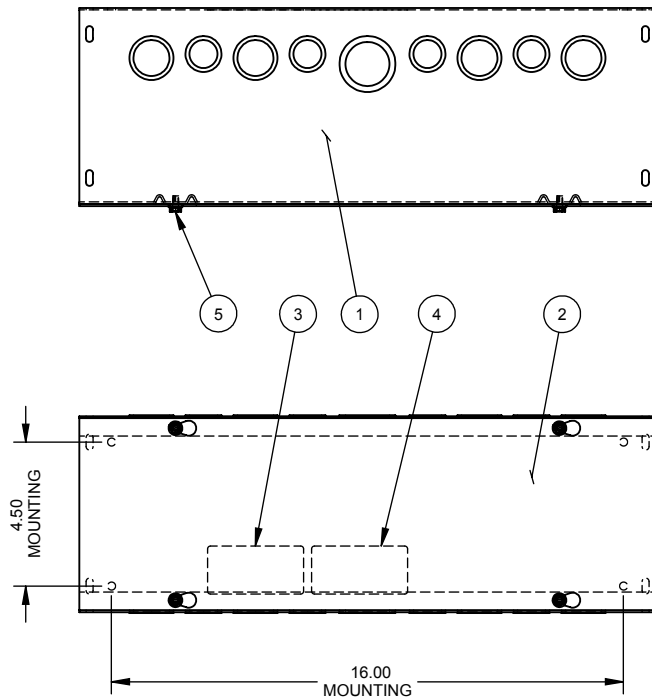

SUFFIX	BACK #	COVER #
-SU	1010678	1011812
-SUC	1128960	1128936
-SO	1128961	1102126
-SUNK	1010680	1011812
-NK	1128962	1102126
-SUNKC	1128963	1128936

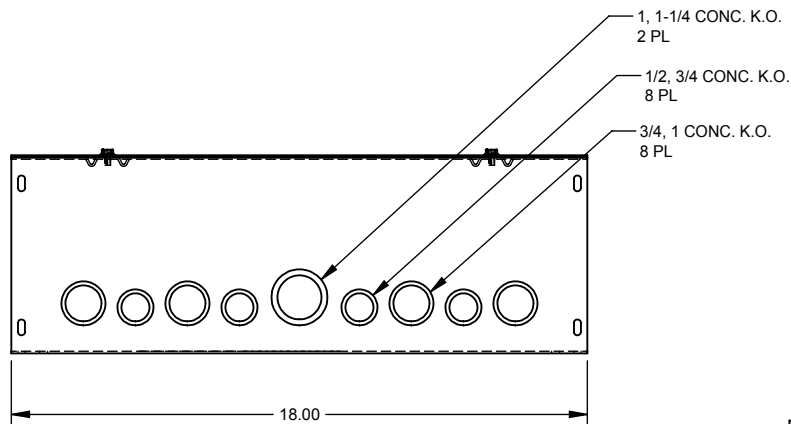
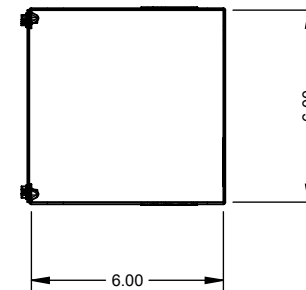

SUFFIX	FINISH
NONE	PAINTED
-NP	NOT PAINTED

NOTE:
1. PLACE BAG ASSY INSIDE ENCLOSURE. (NOT SHOWN)

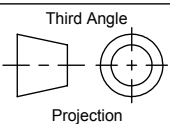
Material:	16 GA. - SEE CHART	 General Offices: Kansas City, MO	
Finish:	SEE CHART		
Tolerances: Unless Specified Otherwise X.X ±.1 X.XX ±.03 X.XXX ±.015 X° ±2°		Title:	SCREW COVER WIREWAY 6 x 6 x 18, TYPE 1 NEMA ENCLOSURE
		Catalog No.:	6618-GSC1
		Customer:	MILBANK STANDARD
		Drawing No.:	1011547
Scale:	NTS	Date:	05/24/02
Drawn By:	DY	Sheet	1 of 1

NEMA DWG.: #248

B	05/24/02	REVISED PER - PMR 2444	DY	C	8-28-07	ADDED BACK & COVER CHART ECO. 15946	DL
B1	8-22-06	mECO #15092, ADDED NOTE #2.	CMW	D	3/13/12	1002880 (2) WAS (4) (ECO #22018)	D.F.