

Well-Guard Control™

Pumping Plant Panels

Catalog

8940CT9701R7/08

2008

Class 8940



IRRIGATION



OIL PRODUCTION

CONTENTS

Description	Page
Selection Guide	Page 3
Factory Modifications	Page 6
Application Data	Page 8
Dimensions	Page 12



SQUARE D

by Schneider Electric

Schneider
Electric

Well-Guard Control™ Pump Panels, Full Voltage—Class 8940 Irrigation Style Selection Guide

Class 8940 Type NP IEC Style Pump Panels, in NEMA Type 3R enclosures, are specifically designed for irrigation applications. All panels are supplied with a visible-blade fused disconnect switch (unless noted). Extra panel space is provided for field installation of auxiliary equipment (refer to page 12 for approximate dimensions).

- Approved for submersible pump applications
- Class 10 bimetallic overload relay through 100 hp–480 V, 50 hp–240 V
- Adjustable trip current
- Includes a Start push button and a Hand-Off-Auto selector switch
- Ambient temperature compensated
- TeSys™ D and TeSys™ F contactors are used as standard
- Sizes closely matched to common motor sizes
- All devices are UL Listed and marked “SUITABLE ONLY FOR USE AS SERVICE EQUIPMENT”

Fusible Disconnect Switch Type

600 Volts Max. – 3-Pole – 50-60 Hertz

Volts	Max. hp Polyphase	Coil Voltage ●	Fuse Clip Amperes ▲	Class 8990 Type ■
240	3	240-60 220-50	30	NPD2003V03
	5		30	NPE2005V03
	7.5		30	NPE2007V03
	10		60	NPF2010V03
	15		60	NPF2015V03
	20		100	NPG2020V03
	25		100	NPG2025V03
	30		100	NPJ2030V03
	40		200	NPJ2040V03
	50		200	NPJ2050V03
	Above 50 hp, see page 4			
480	3	480-60 440-50	30	NPD4003V06
	5		30	NPD4005V06
	7.5		30	NPD4007V06
	10		30	NPE4010V06
	15		30	NPE4015V06
	20		60	NPF4020V06
	25		60	NPF4025V06
	30		60	NPF4030V06
	40		100	NPG4040V06
	50		100	NPG4050V06
	60		100	NPJ4060V06
	75		200	NPJ4075V06
	100		200	NPJ4100V06
Above 100 hp, see page 4.				



Coil Voltage Codes

Voltage		Code
60 Hz	50 Hz	
24 †▼	...	V01
120 †	110	V02
208 †	...	V08
240	220	V03
...	380	V05
480	440	V06
600 †	550	V07

For hp higher than 100, see page 4.

▼ Must be specially wound for NPJ devices.

† Form S (separate control) required for 24 V, 120 V, 208 V, and 600 V coils.

- Coil voltage code must be specified to order this product. Refer to standard voltage codes listed at left.
- ▲ Fuse clips are sized for use with dual-element time-delay fuses.

Well-Guard Control™ Pump Panels, Full Voltage–Class 8940

Irrigation and Oil Field Style Selection Guide

Class 8940 Type NS, SS and XS Pump Panels, in NEMA Type 3R enclosures, are specifically designed for irrigation and oil field applications. All panels are supplied with a visible-blade fused disconnect switch (unless noted). Extra panel space is provided for field installation of auxiliary equipment (refer to page 12 for approximate dimensions).

- Type S contactor provided as standard
- Approved for submersible pump applications
- Class 10 Motor Logic® SSOLR through 200 hp-480 V, 100 hp-240V —Type SS*
- Includes a Start push button and a Hand-Off-Auto selector switch
- Adjustable trip current
- Ambient temperature compensated
- All devices are UL Listed and marked “SUITABLE ONLY FOR USE AS SERVICE EQUIPMENT”

NOTE: The Class 10 Motor Logic SSOLR (solid-state overload relay) does not protect for phase imbalance; however, it does include a rubber boot dust cover.

3-Pole Polyphase – 600Vac Maximum (50-60 Hz) – Fusible Disconnect Switch Type

Volts	Max. hp Polyphase	Coil Voltage †	Fuse Clip Amperes ▲	Class 8940 Type ■
240	3, 5, 7.5	240-60 220-50	30	SSC2007 ◆
	10, 15		60	SSD2015 ◆
	20, 25, 30		100	SSE2030 ◆
	40, 50		200	SSF2050 ◆
	75		LAL36250 *	XSG2075V03 ■
	100		400	SSG2100
	100		LAL36350 *	XSG2100V03 ■
	200		MAL36700 *	XSH2200V03 ■
	250		MAL36800 *	XSJ2250V03 ■
	300		MAL361000 *	XSJ2300V03 ■
480	3, 5, 7.5, 10	480-60 440-50	30	SSC4010 ◆
	15, 20, 25		60	SSD4025 ◆
	30		60	SSD4030 ◆
	40, 50		100	SSE4050 ◆
	60, 75, 100		200	SSF4100 ◆
	150		LAL36250 *	XSG4150V06 ■
	200		400	SSG4200
	200		LAL36350 *	XSG4200V06 ■
	300		MAL36500 *	XSH4300V06 ■
	350		MAL36600 *	XSH4350V06 ■
	400		MAL36700 *	XSH4400V06 ■
	500		MAL36800 *	XSJ4500V06 ■
	600		MAL361000 *	XSJ4600V06 ■

* MAG-GARD circuit breaker disconnect supplied.

▲ Fuse clips are sized for use with dual-element time-delay fuses.

◆ Voltage code not required for 240 V or 480 V with 8940SS___ controllers.

■ Type SSC, SSD, SSE, SSF, SSG, and XSJ panels include the Motor Logic SSOLR and do not require thermal units. Types XSG and XSH panels include a three-unit overload relay. Thermal units must be ordered separately. See Pages 8-9 for selection information.

NOTE: To substitute an ambient compensated bimetallic overload relay (up to size 4) for the Motor Logic SSOLR, request Form B12 and state motor hp (no charge).

3-Pole Polyphase – 600 Volts AC Maximum (50-60 Hz) – Circuit Breaker

Volts	Max. hp Polyphase	Coil Voltage †	Circuit Breaker	Class 8940 Type
240	25	240-60 220-50	FAL36100-18M	XSE2025V03
	30			XSE2030V03
	40		KAL36250-26M	XSE2040V03
	50		KAL36250-29M	XSE2050V03
480	40	480-60 440-50	FAL36100-18M	XSE4040V06
	50			XSE4050V06
	60		KAL36250-25M	XSE4060V06
	75			XSE4075V06
	100		KAL36250-29M	XSE4100V06

† See Page 3 for coil voltage codes.



Well-Guard Control™ Pump Panels, Full Voltage—Class 8940 Oil Field Style Selection Guide

Class 8940 Type S2 Pump Panels, in NEMA Type 3R enclosures, are specifically designed for Oil Field applications. All panels are supplied with a visible-blade fused disconnect switch or a Mag-Gard® circuit breaker, depending on the Type number. Extra panel space is provided for field installation of auxiliary equipment (refer to page 12 for approximate dimensions).

- Rugged spring latches for easy access without a tool
- Side mounted control units for convenient operation
- Door retainer available for windy areas (Form G45)
- Hand-Off-Auto selector switch
- UL Listed for use as Service Equipment for Motors
- Extra panel space for additional electrical controls
- All devices UL Listed and marked “SUITABLE ONLY FOR USE AS SERVICE EQUIPMENT”

NOTE: Overload relays are ambient temperature compensated.

600 Volts Max. – 3-Pole – 50-60 Hertz									
Volts	Coil Voltage *	Max. hp Polyphase	NEMA Size	Fusible Disconnect Type		Circuit Breaker Type			
				Fuse Clip Amperes ★	Class 8940 Type	Frame Size	Class 8940 Type		
240	240 @ 60 Hz 220 @ 50 Hz	7.5	1	30	WC1S2V03	GJL36030M04	XC1S2V03		
		10	2	60	WD1S2V03	GJL36050M05	XD1S2V03		
		15				FAL3610018M	XD2S2V03		
		480	480 @ 60 Hz 440 @ 50 Hz	30	3	100	WE1S2V03	FAL3610018M	XE1S2V03
				40	4	200	WF1S2V03	KAL3625026M	XF1S2V03
				50				KAL3625029M	XF2S2V03
480	480 @ 60 Hz 440 @ 50 Hz			7.5	1	30	WC3S2V06	GJL36015M03	XC3S2V06
		10	GJL36030M04	XC4S2V06					
		15	2	60	WD3S2V06	GJL36030M04	XD3S2V06		
		25				GJL36050M05	XD4S2V06		
		480	480 @ 60 Hz 440 @ 50 Hz	50	3	100	WE3S2V06	FAL3610018M	XE3S2V06
				75	4	200	WF3S2V06	KAL3625025M	XF3S2V06
100	KAL3625029M			XF4S2V06					

- ★ Fuse clips are sized for use with dual-element time-delay fuses.
- Thermal units must be ordered separately.
- * Coil voltages must be specified to order this product. See coil voltage codes below.

Coil Voltage Codes

Voltage		Code
60 Hz	50 Hz	
24 †▲	—	V01
120 †	110	V02
208 †	—	V08
240	220	V03
—	380	V05
480	440	V06
600 †	550	V07

- ▲ 24V coils are not available on Size 4 starters.
On Size 1-3, 24V coils are available. **Form S** must be used.
- † **Form S** (separate control) required for 24 V, 120 V, 208 V, and 600 V coils.



Listed File E152395
CCN NKJH



Listed File E152395
CCN NKJH7

Well-Guard Control™ Pump Panels, Full Voltage–Class 8940

Factory Modifications

Factory Modifications

Description	Form
Start push button in oil field panel (S2) only	A28
Substitute Class 10 IEC overload relay – state motor hp	B12
Control Transformer with Fused Primary: Types: NPD, NPE, NPF, WC, XC, NSC, SSC (50 VA) NPG, NSG, XD, WD, SSD (100 VA) NPJ, NSE, XE, WE, SSE (150 VA) NSF, XF, WF, SSF (300 VA) NSG, XSG, (50 VA and an interposing control relay)	F4T
Door wind latch assembly, factory installed in a standard 8940NPD, NPE, NPF, NPG, NPJ, SSC, SSO, SSE, or SSF panel.	G45
Elapsed time meter	G97
Substitute Class 10 Motor Logic® SSOLR (without phase imbalance protection)	H10
On delay timer, 0.1 seconds to 1 minute	K25
Off delay timer, 0.1 seconds to 1 minute	K26
On delay timer, 1 minute to 3 minute	K37
Off delay timer, 1 minute to 3 minute	K38
Backspin timer (time delay on energization)	K15
Slim panel (Types WC, WD, WF, XC, XD, XF only)	L8
Short Panel (Types SSE, SSF only)	L9
Pilot light, red (does not include auxiliary contact)	P1
Pilot light, green (does not include auxiliary contact)	P2
Separate Control	S
Auxiliary Contacts (Specify N.O. or N.C.)	X ▲
Special UL panel label for modified UL Listed devices on non-standard panels. Requires approval by manufacturing plant.	Y1
Lightning Arrester	Y1532
Phase failure, phase reversal relay with time delay, including undervoltage and overvoltage protection	R44 †
Substitute Standard-Trip Melting Alloy Overload Relays (Type S2 only)	Y61
Substitute Quick-Trip Melting Alloy Overload Relay (Type S2 only)	Y611

† Requires the use of 120 volt control (**Form S** or **FF4T**).

▲ To determine the maximum number of auxiliary contacts which can be added to each Type S device, and for the appropriate X Form, refer to tables in the Class 8536 section of the current *Digest*.

Well-Guard Control™ Pump Panels, Full Voltage–Class 8940 Reduced Voltage Type

Class 8940 Reduced Voltage panels in NEMA Type 3R enclosures are specifically designed for pumping applications. Extra space is provided for field installation of auxiliary equipment.

- Type S contactors/starters provided as standard.
- All devices are UL Listed and marked “SUITABLE ONLY FOR USE AS SERVICE EQUIPMENT.”
- Includes Hand-Off-Auto selector switch and Start push button.

Closed Transition Autotransformer Type

3-Pole Polyphase – 600 Volts AC Maximum – 50-60 Hertz

Motor (Starter) Volts	Max. hp Polyphase	Coil Voltage	NEMA Size	Fusible Disconnect Type		Circuit Breaker Type	
				Fuse Clip Amperes ★	Class 8940 Type ●	Circuit Breaker	Class 8940 Type ●
230 (240)	15	240 @ 60 Hz 220 @ 50 Hz	2	60	RD4DV03	FAL36080	VD1DV03
	25		3	100	RE4FV03	FAL36100	VE1FV03
	30			200	RE1GV03	KAL36100	VE2GV03
	50		5	200	RF4JV03	KAL36200	VF1JV03
	75			400	RG1LV03	LAL36250	VG2LV03
	100		400	RG1MV03	LAL36350	VG2MV03	
460 (480)	25	480 @ 60 Hz 440 @ 50 Hz	2	60	RD2FV06	FAL36070	VD1FV06
	30		3	100	RE2GV06	FAL36080	VE1GV06
	50			100	RE2JV06	FAL36100	VE1JV06
	75		4	200	RF2LV06	KAL36125	VF1LV06
	100			200	RF2MV06	KAL36200	VF1MV06
	150		5	400	RG3PV06	LAL36250	VG4PV06
	200			400	RG3QV06	LAL36350	VG4QV06
	300		6	—	—	MAL36600	VH1SV06
	400			—	—	MAL36900	VH2TV06
	600		7	—	—	MAL36100	VJ1WV06

★ Fuse clips are sized for use with dual-element time-delay fuses.

● Thermal units must be ordered separately.

Part Winding Type

3-Pole Polyphase – 600 Volts AC Maximum – 50-60 Hertz

Motor (Starter) Volts	Max. hp Polyphase	Coil Voltage	NEMA Size	Combination Fusible Disconnect Type		Combination Circuit Breaker Type	
				Fuse Clip (2 sets) Amperes ★	Class 8940 Type ●	Circuit Breaker (2 Bkrs.) Frame Size	Class 8940 Type ●
230 (240)	25	240 @ 60 Hz 220 @ 50 Hz	2PW	60	MD4FV03	FAL36070	PD1FV03
	30		3PW	60	ME5GV03	FAL36080	PE3GV03
	50			100	ME6JV03	FAL36100	PE3JV03
	75		4PW	200	MF1LV03	KAL36150	PF3LV03
	100			200	MG3MV03	KAL36175	PG2MV03
	125		5PW	400	MG1NV03	LAL36250	PG3NV03
150	400	MG1PV03		LAL36250	PG3PV03		
460 (480)	30	480 @ 60 Hz 440 @ 50 Hz	2PW	30	MD5GV06	FAL36040	PD1GV06
	40			60	MD2HV06	FAL36050	PD1HV06
	60		3PW	60	ME7KV06	FAL36070	PE3KV06
	75			100	ME3LV06	FAL36090	PE3LV06
	100		4PW	200	MF3MV06	FAL36100	PF2MV06
	150			200	MF3PV06	KAL36125	PF3PV06
	200		5PW	200	MG4QV06	KAL36175	PG2QV06
	250			200	MG4RV06	LAL36225	PG3RV06
	400		400	MG2TV06	LAL36300	PG3TV06	

★ Fuse clips are sized for use with dual-element time-delay fuses.

● Thermal units required. Order separately. Refer to pages 10–11.



Well-Guard Control™ Pump Panels, Full Voltage–Class 8940

Replacement Part Application Data

Application Data

Class 8940 Type	Disconnect Switch	Fuse Base	Contactors	Overload Relay	Overload Relay Mounting Bracket
NPD2003	40567-200-51*	40566-143-51	LC1D12	LRD16	LAD7B10
NPE2005	40567-200-51*	40566-143-51	LC1D18	LRD21	LAD7B10
NPE2007	40567-200-51*	40566-143-51	LC1D25	LRD22	LAD7B10
NPF2010	40567-200-51*	40566-143-51 (60 A 250 V) 40566-144-51 (60 A 600 V)	LC1D32	LRD32	LAD7B10
NPF2015	40567-200-51*	40566-143-51 (60 A 250 V) 40566-144-51 (60 A 600 V)	LC1D50	LRD3357	LA7D3064
NPG2020	31301-056-65	31301-059-50	LC1D65	9065TJF40	NA
NPG2025	31301-056-65	31301-059-50	LC1D80	9065TJF40	NA
NPJ2030	31301-056-65	31301-059-50	LC1F115	9065TJF63	NA
NPJ2040	31055-366-51	Included with switch	LC1F115	9065TJF63	NA
NPJ2050	31055-366-51	Included with switch	LC1F150	9065TJF100	NA
NPD4003	40567-200-51*	40566-143-51	LC1D09	LRD10	LAD7B10
NPD4005	40567-200-51*	40566-143-51	LC1D09	LRD12	LAD7B10
NPD4007	40567-200-51*	40566-143-51	LC1D12	LRD16	LAD7B10
NPE4010	40567-200-51*	40566-143-51	LC1D18	LRD21	LAD7B10
NPE4015	40567-200-51*	40566-143-51	LC1D25	LRD22	LAD7B10
NPF4020	40567-200-51*	40566-143-51 (60 A 250 V) 40566-144-51 (60 A 600 V)	LC1D32	LRD32	LAD7810
NPF4025	40567-200-51*	40566-143-51 (60 A 250 V) 40566-144-51 (60 A 600 V)	LC1D40	LRD3355	LA7D3064
NPF4030	40567-200-51*	40566-144-51 (60 A 250 V)	LC1D50	LRD3357	LA7D3064
NPG4040	31301-056-65	31301-059-50	LC1D65	9065TJF40	NA
NPG4050	31301-056-65	31301-059-50	LC1D80	9065TJF40	NA
NPJ4060	31301-056-65	31301-054-50	LC1F115	9065TJF63	NA
NPJ4075	31055-366-51	Included with switch	LC1F115	9065TJF63	NA
NPJ4100	31055-366-51	Included with switch	LC1F150	9065TJF100	NA

* Includes switch base and operating mechanism. To ensure handle compatibility, part number HM0610F must also be purchased.

NOTE: Two operating mechanisms will be shipped; keep one mechanism as a spare.

Well-Guard Control™ Pump Panels, Full Voltage–Class 8940 Replacement Part Application Data

Application Data

Class 8940 Type	Disconnect Switch	Fuse Base	Contactor	Overload Relay
SSC2007	40567-200-51*	40566-143-51	8502SCO2	31161-547-64
SSD2015	40567-200-51*	40566-143-51 (60 A 250 V) 40566-144-51 (60 A 600 V)	8502SDO2	31161-548-83
SSE2030	31301-056-65	31301-059-50	8052SEO2	31161-551-58
SSF2050	31055-366-51	Included with switch	8502SFO2	31161-551-58
SSC4010	40567-200-51*	40566-143-51	8052SCO2	31161-547-64
SSD4025	40567-200-51*	40566-143-51 (60 A 250 V) 40566-144-51 (60 A 600 V)	8502SDO2	31161-548-83
SSD4030	40567-200-51*	40566-143-51 (60 A 250 V) 40566-144-51 (60 A 600 V)	8502REQ2617G	31161-548-83
SSE4050	31301-056-65	31301-059-50	8502SEO2	31161-551-58
SSF4100	31055-366-51	Included with switch	8502SFO2	31161-553-68
XSG2075	LAL36250	NA	8502SGO2	9065SE06B
SSG2100	9422TG2	NA	31102-668-50	31161-184-74
XSG2100	LAL36350	NA	8502SGO2	9065SE06B
XSH2200	MAL36700	NA	8536SHO2	9065SE06B
XSJ2250	MAL36800	NA	8536JO2	9065SE06B
XSJ2300	MAL361000	NA	8536JO2	9065SE06B
XSG4150	LAL36250	NA	8502SGO2	9065SE06B
SSG4200	9422TG2	NA	31102-668-00	31161-184-74
XSG4200	LAL36350	NA	8502SGO2	9065SE06B
XSH4300	MAL36500	NA	8536SHO2	9065SE06B
XSH4300	MAL36600	NA	8536SHO2	9065SE06B
XSH4400	MAL36700	NA	8536SHO2	9065SE06B
XSJ4500	MAL36800	NA	8536JO2	31161-184-77
XSJ4600	MAL361000	NA	8536JO2	31161-184-77

* Includes switch base and operating mechanism. To ensure handle compatibility, part number HM0610F must also be purchased.

NOTE: Two operating mechanisms will be shipped; keep one as a spare.

Class 8940 Electrical Interlocks

Disconnect Switches			Circuit Breakers		
Rating			Style		
	SPDT	DPDT		SPDT	DPDT
30A	EIK1*	EIK2*	GJL	NA	NA
60A	EIK1*	EIK2*	FAL	9999R26	9999R27
100A	9999TC10	9999TC20	KAL	9999R26	9999R27
200A	9999R39	9999R40	LAL	9999R26	9999R27
400A	9999R35	9999R36	MAL	9999R26	9999R27

* No class number required.

Well-Guard Control™ Pump Panels, Full Voltage–Class 8940 Thermal Units

Bimetallic Thermal Unit Selection Tables Based on Motor Full Load Current

Table A - NEMA Size 1 (Table 33)

Types WC, XC	
Motor Amperes	Thermal Unit
6.28-6.97	AR 10.2
6.98-7.59	AR 11.2
7.60-7.89	AR 12.4
7.90-8.95	AR 13.6
8.96-10.3	AR 15.4
10.4-11.7	AR 17.6
11.8-13.3	AR 20.5
13.4-15.2	AR 23
15.3-17.2	AR 27
17.3-19.7	AR 30
19.8-22.4	AR 35
22.5-26.0	AR 40

Table B - NEMA Size 2 (Table 70)

Types MD, PD, RD, VD, WD, XD	
Motor Amperes	Thermal Unit
8.56-9.74	AR 17.6
9.75-11.1	AR 20.5
11.2-12.7	AR 23
12.8-14.4	AR 27
14.5-16.4	AR 30
16.5-18.9	AR 35
19.0-21.6	AR 40
21.7-23.3	AR 44
23.4-24.9	AR 47
25.0-26.9	AR 51
27.0-29.1	AR 55
29.2-31.3	AR 60
31.4-33.5	AR 66
33.6-36.9	AR 72
37.0-39.1	AR 79
39.2-40.9	AR 86
41.0-45.0	AR 94

Table C - NEMA Size 3 (Table 37)

Types ME, PE, RE, VE, WE, XE	
Motor Amperes	Thermal Unit
27.1-30.0	E 67
30.1-33.2	E 69
33.3-35.7	E 70
35.8-39.4	E 71
39.5-43.4	E 72
43.5-46.9	E 73
47.0-51.5	E 74
51.6-57.0	E 76
57.1-62.8	E 77
62.9-69.1	E 78
69.2-75.0	E 79
75.1-83.3	E 80

- * These thermal unit selections are for controllers protected from solar radiation and located in an ambient temperature of 40 °C (104 °F) or less. For overload relays which are not ambient temperature compensated (NEMA Size 3 and 4), thermal units larger than normal can be required under conditions of high ambient temperature and/or solar radiation. Consult your local Square D field office.
- To select thermal units for Type M part winding devices, first divide total motor full load current by 2. Use tables above.

NOTE: This is a partial Thermal Unit Selection Table listing. The complete list can be found in the current *Digest*.

Table D - NEMA Size 4 (Table 29)

Types MF, PF, RF, VF, WF, XF	
Motor Amperes	Thermal Unit
50.0-55.9	E 88
56.0-60.9	E 89
61.0-65.9	E 91
66.0-69.9	E 92
70.0-75.9	E 93
76.0-81.9	E 94
82.0-86.9	E 96
87.0-92.9	E 97
93.0-97.9	E 98
98.0-107.9	E 99
108.0-113.9	E 101
114.0-125.9	E 102

‡ Order Type E thermal units by number from Square D Company, Furnas Electric Company, Batavia, IL or a Furnas Distributor.

Table E - NEMA Size 5 (Table 46)

Types MG, PG, RG, VG, WG, XG	
Motor Amperes	Thermal Unit
105-116	AR 3.28
117-132	AR 3.62
133-148	AR 3.98
149-165	AR 4.37
166-184	AR 4.80
185-207	AR 5.30
208-229	AR 5.8
230-266	AR 6.4

▲ With 300:5 Current Transformer Ratio. Across-the-line and auto-transformer type reduced voltage.

Table F - NEMA Size 6 (Table 47)

Type VH, XH	
Motor Amperes	Thermal Unit
146-169	AR 1.68
170-185	AR 1.85
186-201	AR 2.04
202-217	AR 2.24
218-236	AR 2.46
237-253	AR 2.71
254-279	AR 2.98
280-311	AR 3.28
312-353	AR 3.62
354-396	AR 3.98
397-442	AR 4.37
443-492	AR 4.80
493-520	AR 5.30

▲ With 800:5 Current Transformer Ratio. Auto-transformer type reduced voltage.

Table G - NEMA Size 7

Type	
Motor Amperes	Thermal Unit

Motor Logic SSOLR
Adjustable 270-810 Full Load Current (Ambient Insensitive)

Well-Guard Control™ Pump Panels, Full Voltage—Class 8940 Thermal Units

Melting Alloy Quick Trip Thermal Unit Selection Tables (Form Y611) Based on Motor Full Load Current*

Table H - NEMA Size 1 (Table 78)

Types WC, XC	
Motor Amperes	Thermal Unit
2.26-2.51	FB 3.33
2.52-2.81	FB 3.71
2.82-3.09	FB 4.1
3.10-3.30	FB 4.5
3.31-3.69	FB 4.75
3.70-4.27	FB 5.3
4.28-4.72	FB 6.1
4.73-5.25	FB 6.75
5.26-5.53	FB 7.45
5.54-5.81	FB 7.8
5.82-6.14	FB 8.2
6.15-6.44	FB 8.6
6.45-6.81	FB 9.0
6.82-7.19	FB 9.5
7.20-7.59	FB 10
7.60-7.99	FB 10.6
8.00-8.17	FB 11.2
8.18-8.74	FB 12.1
8.75-9.31	FB 13.1
9.32-9.94	FB 13.9
9.95-10.5	FB 14.8
10.6-11.1	FB 15.6
11.2-12.0	FB 16.4
12.0-12.4	FB 17.6
12.5-13.1	FB 18.4
13.2-14.3	FB 19.4
14.4-15.3	FB 21.1
15.4-15.9	FB 22.6
16.0-16.9	FB 23.6
17.0-18.3	FB 24.8
18.4-19.5	FB 26.7
19.6-20.5	FB 28.3
20.6-21.1	FB 29.6
21.2-22.6	FB 30.5
22.7-23.7	FB 32.6
23.8-24.3	FB 34.1
24.4-26.0	FB 35

Table J - NEMA SIZE 3 (Table 80)

Types WE, XE	
Motor Amperes	Thermal Unit
20.5-21.7	FB 26.7
21.8-23.1	FB 28.3
23.2-24.8	FB 29.6
24.9-26.5	FB 30.5
26.6-28.4	FB 32.6
28.5-30.4	FB 34.1
30.5-32.8	FB 38.3
32.9-34.9	FB 40.2
35.0-37.3	FB 42
37.4-39.8	FB 44
39.9-42.5	FB 46
42.6-45.8	FB 48
45.9-48.2	FB 50.5
48.3-50.6	FB 52.5
50.7-53.1	FB 55.5
53.2-56.5	FB 58
56.6-59.4	FB 60
59.5-63.4	FB 63.5
63.5-71.0	FB 69
71.1-78.8	FB 77
78.9-86.0	FB 84

Table I - NEMA SIZE 2 (Table 79)

Types WD, XD	
Motor Amperes	Thermal Unit
4.24-4.69	FB 6.1
4.70-5.21	FB 6.75
5.22-5.49	FB 7.45
5.50-5.74	FB 7.8
5.75-6.07	FB 8.21
6.08-6.35	FB 8.6
6.36-6.71	FB 9.0
6.72-7.03	FB 9.5
7.04-7.53	FB 10
7.54-7.91	FB 10.6
7.92-8.53	FB 11.2
8.54-9.14	FB 12.1
9.15-9.71	FB 13.1
9.72-10.2	FB 13.9
10.3-10.8	FB 14.8
10.9-11.5	FB 15.6
11.6-12.3	FB 16.4
12.4-13.0	FB 17.6
13.1-13.9	FB 18.4
14.0-15.1	FB 19.4
15.2-16.1	FB 21.1
16.2-16.9	FB 22.6
17.0-17.9	FB 23.6
18.0-19.4	FB 24.8
19.5-20.7	FB 26.7
20.8-21.7	FB 28.3
21.8-22.3	FB 29.6
22.4-23.9	FB 30.5
24.0-25.1	FB 32.6
25.2-25.9	FB 34.1
26.0-27.1	FB 35
27.2-28.6	FB 36.6
28.7-30.1	FB 38.3
30.2-31.7	FB 40.2
31.8-33.3	FB 42
33.4-34.5	FB 44
34.6-36.5	FB 46
36.8-38.5	FB 48
38.6-39.9	FB 50.5
40.0-45.0	FB 52.5

Table K - NEMA SIZE 4 (Table 81)

Types WF, XF	
Motor Amperes	Thermal Unit
52.2-55.6	FB 50.5
55.7-58.8	FB 52.5
58.9-62.5	FB 55.5
62.6-66.0	FB 58
66.1-70.1	FB 60
70.2-78.6	FB 63.5
78.7-92.0	FB 69
92.1-102	FB 77
103-114	FB 84
115-123	FB 92
124-133	FB 105

* These thermal unit selections are for controllers protected from solar radiation and located in an ambient temperature of 40°C (104°F) or less. For overload relays which are not ambient temperature compensated (NEMA Size 3 and 4), thermal units larger than normal can be required under conditions of high ambient temperature and/or solar radiation. Consult your local Square D field office.

NOTE: This is a partial Thermal Unit Selection Table listing. The complete list can be found in the current *Digest*.

Well-Guard Control™ Pump Panels, Full Voltage–Class 8940

Replacement Part Application Data

Approximate Dimensions

Type	Fig.	Dim.	A	B	C	D	E	F	G	H	J	K	Conduit L	M	Knockout			V
															R	S	T	
NPD NPE NPF SSC	1	in.	39.05	13.73	6.67	9.70	33.05	37.93	7.00	2.41	3.00	3.00	1-1/2	2.41	1/2, 3/4	1-1/4, 1-1/2	1/2,3/4	1.41
		mm	992	349	169	246	839	963	178	61	76	76						61
NPG NPJ SSE SSF XSE	2	in.	49	19.15	8.81	10.37	44.07	47.88	7.00	2.17	2.69	3.44	2-1/2	2.57	1/2, 3/4	1-1/4 1,2-1/2	1,1-1/4 1-1/2,2	1.41
		mm	1245	486	249	263	1119	1216	178	55	68	87						65

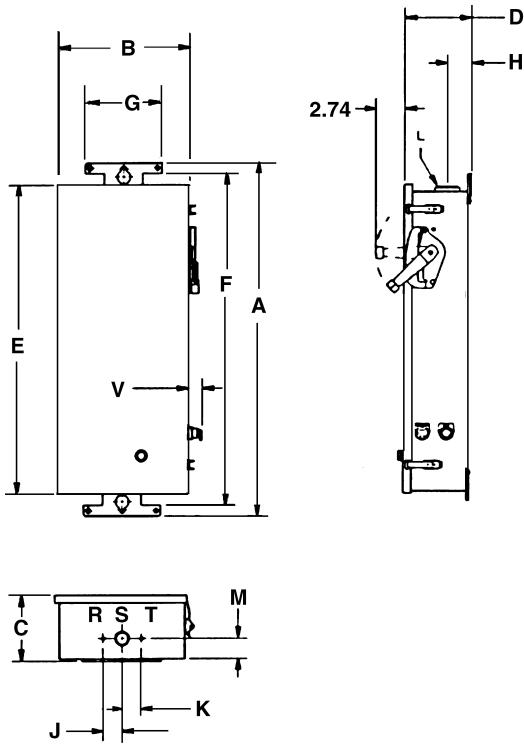

Figure 1

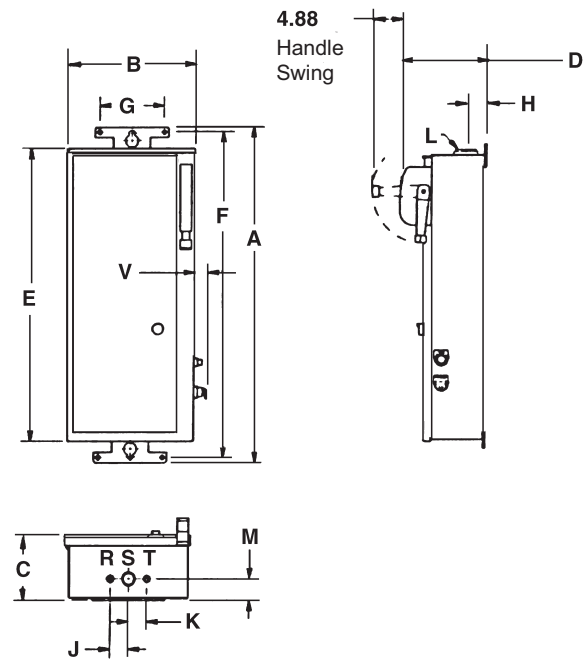

Figure 2

Dual Dimensions: $\frac{\text{in.}}{\text{mm}}$

Well-Guard Control™ Pump Panels, Full Voltage—Class 8940 Replacement Part Application Data

Approximate Dimensions

Type	Fig.	Dimensions	A	B	C	D	E	F	G	H	J	K	Conduit L	M	Knockout			V
															R	S	T	
WC-S2 WD-S2 XC-S2	1	in.	38.50	19.00	7.29	9.39	34.00	37.38	7.00	2.18	2.13	2.13	1-1/2	2.12	1/2-3/4	1, 1-1/4, 1-1/2	1/2, 3/4	—
		mm	978	483	185	539	864	949	178	55	54	54		54				—
WE-S2 WF-S2 XE-S2	1	in.	56.50	23.00	8.23	10.33	52.00	55.38	7.00	2.18	2.69	3.44	1/2	2.68	1/2-3/4	1, 1-1/4, 2, 2-1/2	1, 1-1/4, 1-1/2, 2	1.50
		mm	1435	584	209	262	1321	1407	178	55	68	87		68				38
NSG XSG	2	in.	74.50	22.00	13.80	17.55	73.00	0.50	14.00	—	0.56	—	—	—	—	—	—	1.50
		mm	1892	559	351	446	1854	13	356	—	14	—	—	—	—	—	—	38
XSH	3	in.	82.50	36.00	20.00	23.25	80.00	33.75	16.50	—	—	—	—	—	—	—	—	—
		mm	2096	914	508	591	2032	857	419	—	—	—	—	—	—	—	—	—
XSJ	3	in.	92.50	34.00	20.00	23.25	90.00	31.75	16.50	—	—	—	—	—	—	—	—	—
		mm	2350	864	508	591	2286	806	419	—	—	—	—	—	—	—	—	—

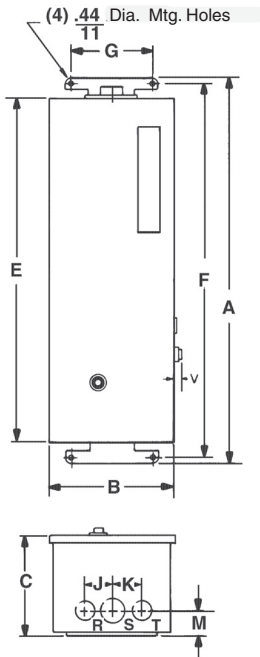

Figure 1

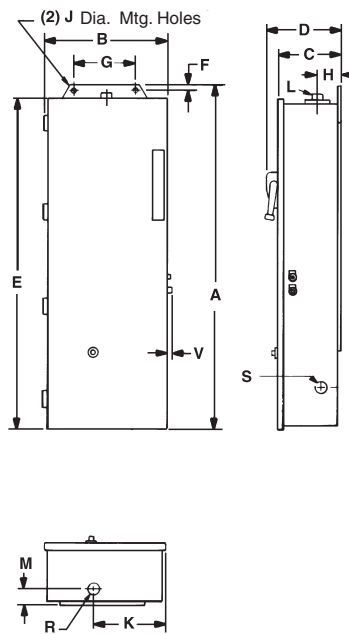

Figure 2

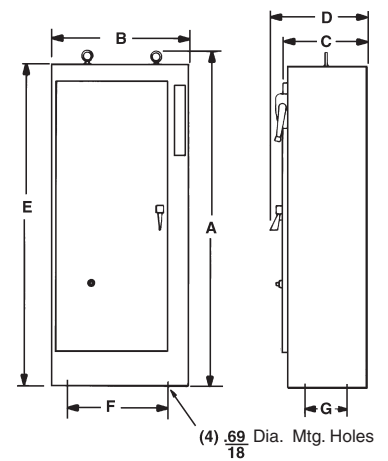

Figure 3

Dual Dimensions: $\frac{\text{in.}}{\text{mm}}$

Well-Guard Control™ Pump Panels, Full Voltage–Class 8940

Replacement Part Application Data

Part Winding - Reduced Voltage Type

Type	Dimensions *	A	B	C	D	E	F	Figure
PD	in.	19.00	34.50	12.25	13.00	33.50	0.44	2
	mm	483	876	311	330	851	11	
MD	in.	23.00	25.50	10.60	17.00	24.50	0.44	1
	mm	584	648	269	432	622	11	
PE	in.	30.00	47.00	13.25	22.00	46.00	0.56	2
	mm	762	1194	337	559	1168	14	
ME	in.	25.00	52.50	12.13	19.00	51.50	0.44	2
	mm	635	1334	308	483	1308	11	
MF	in.	36.00	93.00	19.25	33.75	12.50	0.69	3
	mm	914	2362	489	857	318	18	
PG	in.	36.00	73.00	19.25	33.75	12.50	0.69	3
	mm	914	1854	489	857	318	18	
PH	in.	38.00	93.00	19.25	35.75	12.50	0.69	3
	mm	965	2362	489	908	318	18	

Auto-transformer - Reduced Voltage Type

Type	Dimensions *	A	B	C	D	E	F	Figure
RD	in.	25.00	52.50	11.13	19.00	51.50	0.44	2
	mm	635	1334	283	483	1308	11	
VD	in.	32.00	72.50	19.25	29.75	12.50	0.68	3
	mm	813	1842	489	756	318	17	
RE, VE	in.	32.00	72.50	19.25	29.75	12.50	0.68	3
	mm	813	1842	489	756	318	17	
RF, VF	in.	36.00	93.00	19.25	33.75	12.50	0.69	3
	mm	914	2362	489	857	318	17	
RG	in.	32.00	72.50	19.25	29.75	12.50	0.68	3
	mm	813	1842	489	756	318	17	
VG	in.	34.00	93.00	23.25	3133.75	16.50	0.69	3
	mm	864	2362	591	806	419	17	
VH	in.	64.00	93.00	27.25	61.75	17.25	0.81	3†
	mm	1626	2362	692	1568	438	21	

† Cabinet has double doors

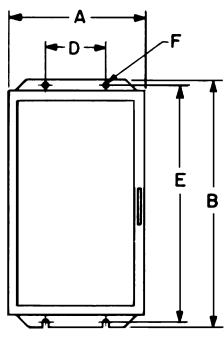

Figure 1

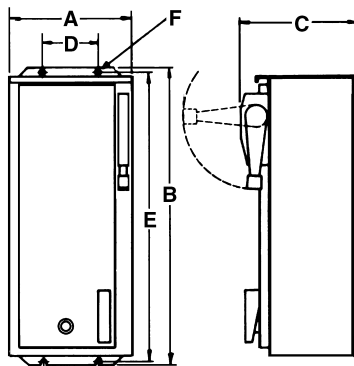

Figure 2

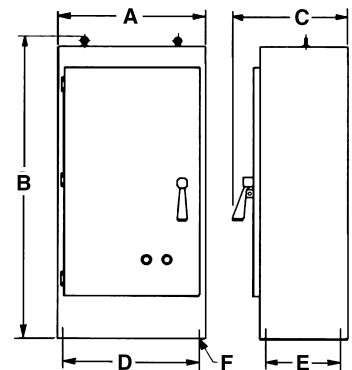

Figure 3

* Dual Dimensions: $\frac{\text{in.}}{\text{mm}}$

Well-Guard Control™
Replacement Part Application Data

Schneider Electric USA

8001 Knightdale Blvd.
Knightdale, NC 27545
1-888-Square D
1-888-778-2733
www.schneider-electric.us

8940CT9701R7/08 © 1997-2008 Schneider Electric All Rights Reserved
Replaces 8940CT9701, December 1997