

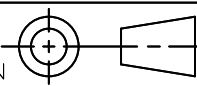
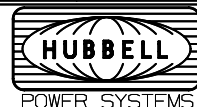
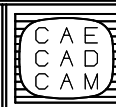

CATALOG NO.	DESCRIPTION	'A''	'B''	'L''
7020	FLAT STEEL CROSSARM BRACE	9/16	7/16	20
7026	FLAT STEEL CROSSARM BRACE	9/16	7/16	26
7028	FLAT STEEL CROSSARM BRACE	9/16	7/16	28
7030	FLAT STEEL CROSSARM BRACE	9/16	7/16	30
7032	FLAT STEEL CROSSARM BRACE	9/16	7/16	32

- NOTES-
- MAT'L: STEEL PER TT-170
 - HOT DIP GALVANIZE PER ASTM A153 (LATEST REV)

LATEST EC NO:		REV.	DATE	CHANGED BY	RESP ENGINEER
---		-	-----	---	WITTEN
				DO NOT SCALE THIS DWG	THIRD ANGLE PROJECTION 
				ISO DUAL DIMENSIONS IN=INCH, MM=MILLIMETER	
DRN BY:	DATE	TITLE:			SIZE
BERGER	08/27/12	FLAT STEEL CROSSARM BRACE			B
				DWG NO: SA7020	
					

CONFIDENTIAL: THIS DRAWING AND ITS CONTENTS ARE CONFIDENTIAL AND THE EXCLUSIVE PROPERTY OF HUBBELL POWER SYSTEMS, INC. NO PUBLICATION, DISTRIBUTION OR COPIES MAY BE MADE WITHOUT WRITTEN CONSENT BY HUBBELL POWER SYSTEMS, INC. © 2012 HUBBELL POWER SYSTEMS. UNPUBLISHED, ALL RIGHTS RESERVED UNDER THE COPYRIGHT LAWS