

# CS6370

## Brand Features

Leviton's Industrial Grade Locking Devices are built to provide unparalleled quality and superior performance in the most severe industrial settings. Leviton combines the best materials available with superior production standards to produce a broad selection of Locking Devices of unmatched flexibility and dependability.

## Item Description

50Amp, 125V AC, Non-NEMA, 2P, 3W, Black & White Locking Flush Mount Receptacle, Industrial Grade, Grounding, California-Style(CS) – BLACK



**Color:**  Black

**UPC Code:** 07847732603

**Country Of Origin:** Mexico

**NEMA:**  
Non-NEMA



## Technical Information

### Electrical Specifications

**Grounding:** Grounding

**Amperage:** 50 A

**Voltage:** 125 VAC

**Pole:** 2

**Wire:** 3

**Dielectric Voltage Withstand:** 2000V minimum per UL 498

**Maximum Working Voltage:** 125V as rated

**Current Interrupting:** Certified for current interrupting at full rated current

**Temperature Rise:** Max 30°C temp rise at full-rated current after 150 cycles of OL at 150% rated DC current

### Environmental Specifications

**Flammability:** Rated V-0 per UL 94

**Operating Temperature:** -40°C to 75°C

**Environment:** Dry

### Material Specifications

**Face Module:** Reinforced Nylon

**Body & Contract Carrier:** Reinforced Nylon

**Shroud:** .062inch thick Nickel Plated Steel

**Back Cover:** Reinforced Nylon

**Mounting Strap:** Single piece SS 302/304

**Mounting Screws:** SS 302/304

**Assembly Rivets:** SS 302/304

**Center Pin:** SS 302/304

**Connector Contact - Spring:** 0.041inch thick Brass

**Connector Contact - Binding Plate:** 0.100inch thick Brass

**Contact Rivet:** Brass

**Box Terminal:** 0.062inch thick Copper

**Terminal Set Screw:** SS 302/304

**Color:** Black

### Mechanical Specifications

**Terminal ID:** X, W, Y, Z and Green for ground

**Terminal Accom.:** #10min to #6max AWG Solid or Stranded Wire (Stranded Wire for Ground only)

**Product ID:** Ratings and Catalogue No. molded into face

### Product Features

**NEMA:** Non-NEMA

**Color:** Black

**Device Type:** Locking Receptacle

**Brand:** Black and White

### Standards and Certifications

**UL 498:** File E13399

**CSA C22.2 No. 42:** File 152105

**NOM:** 057

**RoHS:** Compliant

**Warranty:** Lifetime Limited

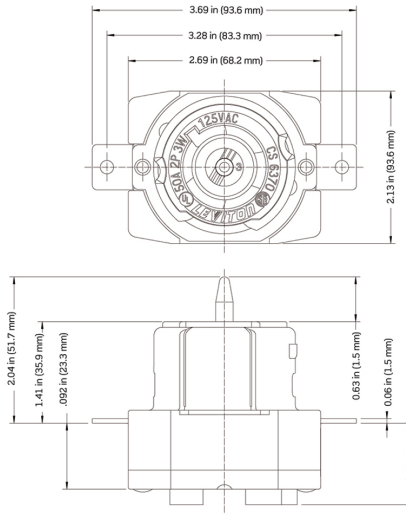

**SPECIFICATION SUBMITTAL**

JOB NAME: <input type="text"/> JOB NUMBER: <input type="text"/>	CATALOG NUMBERS: <input type="text"/> <input type="text"/>
--	--

**Leviton Manufacturing Co., Inc.**

201 North Service Road, Melville, NY 11747

Teléfono: +1-800-323-8920 · FAX: +1-800-832-9538 · Tech Line (8:30AM-7:30PM E.S.T. Monday-Friday): +1-800-824-3005

**Leviton Manufacturing of Canada, Ltd.**

165 Hymus Boulevard, Pointe Claire, Quebec H9R 1E9 · Telephone: +1-800-469-7890 ·

FAX: +1-800-824-3005 · [www.leviton.com/canada](http://www.leviton.com/canada)

**Leviton S. de R.L. de C.V.**

Lago Tana 43, Mexico DF, Mexico CP 11290 · Tel.: (+52)55-5082-1040 · FAX: (+52)5386-

1797 · [www.leviton.com.mx](http://www.leviton.com.mx)

Visit our Website at: [www.leviton.com](http://www.leviton.com)

© 2018 Leviton Manufacturing Co., Inc. Todos los derechos reservados. Subject to change without notice.

**Leviton has a global presence.**

If you would like to know where your local Leviton office is located please go to:

[www.leviton.com/international/contacts/](http://www.leviton.com/international/contacts/)

