

Twist-Lock® Devices

30A, 250V AC, 2 Pole, 3 Wire Grounding

Watertight Safety-Shroud® Receptacle

Features

- High impact, thermoplastic housing for heavy-duty industrial environments
- Alignment arrows with lock and unlock symbols provide a visual indication that devices are properly connected
- Catalog number and color coded voltage rating are visible even when in use

Ordering Information

Description	Device Color	UPC	Catalog Number
PBT housing and flange.	Gray	783585231662	HBL2620SW

Standards

Listed to UL 498
Fed.Spec. W-C-596
Certified to CSA C22.2 No.42
UL Listed, CSA Certified to Type 4, 4X and Type 12

Specifications

Housing / Cover	Gray RPT
Terminal Retainer	Clear polycarbonate
Body Contact Carrier	Natural (white) nylon
Drive Screws	Steel, zinc plated
Contacts	Brass
Lift-Cover Spring & Pin	Stainless Steel

Performance

Electrical	
Current Interrupting	Certified for current interrupting at full rated current
Dielectric Voltage	Withstands 2,000V minimum

Mechanical

Terminal Accommodation	#16 AWG - #8 AWG solid or stranded copper wire only.
Terminal Identification	Terminals identified in accordance with UL 498

Environmental

Flammability	V2 or better per UL94/CSA 22.2 No.0.17
Moisture Resistance	IP20 Suitability
Operating Temperatures	Maximum Continuous 75°C; Minimum -40°C (w/o impact)

Accessories

Watertight Safety Shroud Plug	HBL2621SW
Non-Metallic Backbox	BB2030N
2-Gang Weatherproof Box Adapter Plate	HBL2030AP
Mechanical Interlock	HBLMITL

Online Resources

eCatalog

HUBBELL

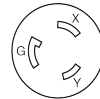

30A 250V
NEMA L6-30R
UL/CSA
2 HP

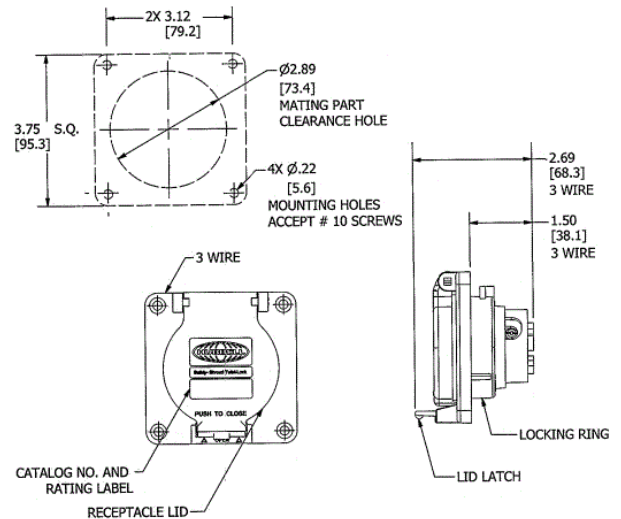

Dimensions in Inches (mm)

Hubbell Wiring Device-Kellems • Hubbell Incorporated (Delaware) • 40 Waterview Drive • Shelton, CT 06484

Phone (800) 288-6000 • Fax (800) 255-1031 • Specifications subject to change without notice.

